

**CURRENT MODE PWM CONTROLLER****AZ3842/3/4/5****General Description**

The AZ3842/3/4/5 are high performance fixed frequency current-mode PWM controller series.

These integrated circuits are optimized for off-line and DC-DC converter applications with minimum external components. They feature under-voltage lockout (UVLO) circuit for low start-up current, trimmed oscillator for precise duty cycle control, current sense comparator providing maximum current limiting and a totem pole output stage for increasing output current. In addition, these ICs also feature accurate protection against over-temperature, over-current and maximal output power.

The AZ3842 and AZ3844 have UVLO thresholds of 15.5V(on) and 10V(off); The corresponding thresholds for AZ3843 and AZ3845 are 8.4 V(on) and 7.8V(off).

The AZ3842 and AZ3843 can operate approaching 100% duty cycle; AZ3844 and AZ3845 can operate from zero to 50% duty cycle.

These ICs are available in 3 packages: SOIC-8, DIP-8 and SOIC-14.

Features

- Robust V_{REF} Line/Load Regulation
Low Line Regulation : 4mV
Low Load Regulation : 4mV
- High Stability of Reference Voltage over a Full Temperature Range: 0.2mV/ °C
- Operating Frequency up to 500KHz
- High PWM Frequency Stability over a Full Temperature Range: 2.5%
- High PWM Frequency Stability under a Full Supply Voltage Range: 0.2%
- Accurate Over-temperature Protection with Hysteresis
- UVLO with Hysteresis

Applications

- Off-line Converter
- DC-DC Converter
- Voltage Adapter
- CRT Monitor Power Supply
- Desktop Power Supply
- DVD/STB Power Supply

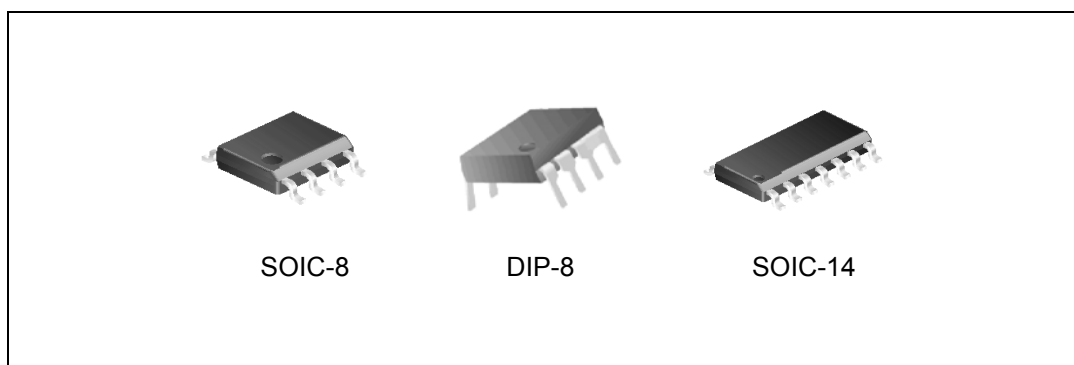


Figure 1. Package Types of AZ3842/3/4/5

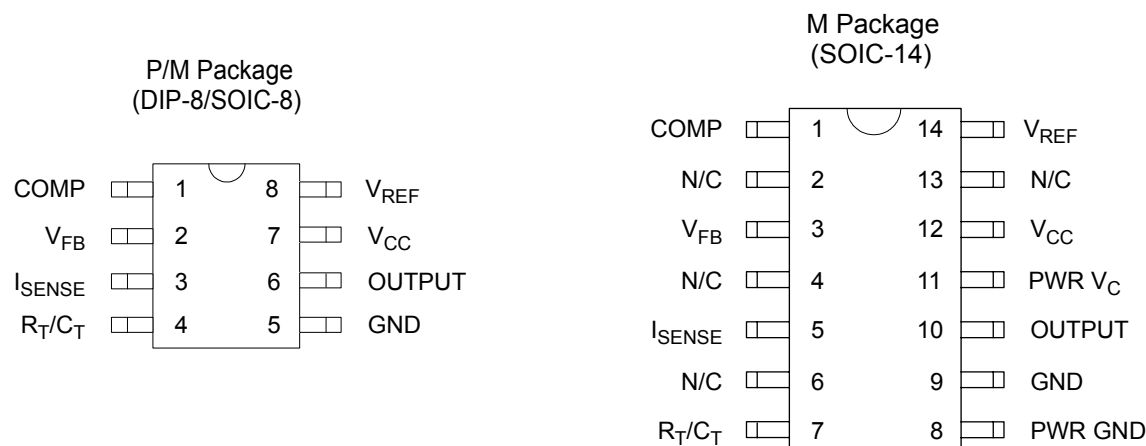
**CURRENT MODE PWM CONTROLLER****AZ3842/3/4/5****Pin Configuration**

Figure 2. Pin Configuration of AZ3842/3/4/5 (Top View)

Pin Description

Pin Number		Pin Name	Function
8-pin	14-pin		
1	1	COMP	This pin is the Error Amplifier output and is made available for loop compensation.
2	3	V _{FB}	The inverting input of the Error Amplifier. It is normally connected to the switching power supply output through a resistor divider.
3	5	I _{SENSE}	A voltage proportional to inductor current is connected to this input. The PWM uses this information to terminate the output switch conduction.
4	7	R _T /C _T	The Oscillator frequency and maximum Output duty cycle are programmed by connecting resistor R _T to V _{REF} and capacitor C _T to ground. Operation to 500 kHz is possible.
5		GND	The combined control circuitry and power ground.
6	10	OUTPUT	This output directly drives the gate of a power MOSFET. Peak currents up to 1.0 A are sourced and sunk by this pin.
7	12	V _{CC}	The positive supply of the control IC.
8	14	V _{REF}	This is the reference output. It provides charging current for capacitor C _T through resistor R _T .
	8	PWR GND	This pin is a separate power ground return that is connected back to the power source. It is used to reduce the effects of switching transient noise on the control circuitry.
	11	PWR V _C	The Output high state (V _{OH}) is set by the voltage applied to this pin. With a separate power source connection, it can reduce the effects of switching transient noise on the control circuitry.
	9	GND	This pin is the control circuitry ground return and is connected back to the power source ground.
	2,4,6,13	N/C	No connection. These pins are not internally connected.

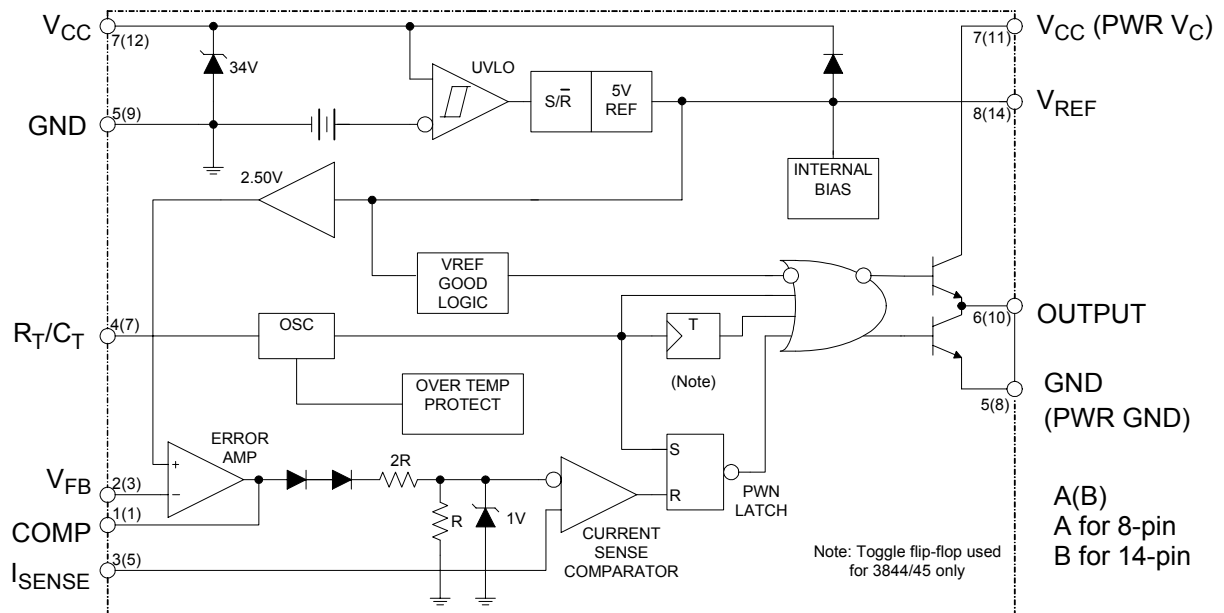
**CURRENT MODE PWM CONTROLLER****AZ3842/3/4/5****Functional Block Diagram**

Figure 3. Functional Block Diagram of AZ3842/3/4/5

Ordering Information

Package	Temperature Range	Part Number	Marking ID	Packing Type
SOIC-8	-40°C~85°C	AZ3842/3/4/5M	3842/3/4/5M	Tape/Reel/Tube
DIP-8		AZ3842/3/4/5P	AZ3842/3/4/5P	Tube
SOIC-14		AZ3842/3/4/5MM	AZ3842/3/4/5MM	Tape/Reel

**CURRENT MODE PWM CONTROLLER****AZ3842/3/4/5****Absolute Maximum Ratings (Note 1, 2)**

Parameter	Symbol	Value	Unit
Supply Voltage	V _{CC}	30	V
Output Current	I _O	± 1	A
Analog Inputs (8-pin: pin2,3, 14-pin: pin3,5)	V(ANA)	-0.3 to 6.3	V
Error Amp Output Sink Current	I _{SINK(E.A)}	10	mA
Power Dissipation at T _A < 25 °C (DIP-8)	P _D (Note 3)	1000	mW
Power Dissipation at T _A < 25 °C (SOIC-8)	P _D (Note 3)	460	mW
Power Dissipation at T _A < 25 °C (SOIC-14)	P _D (Note 3)	725	mW
Storage Temperature Range	T _{STG}	-65 ~ +150	°C
Lead Temperature (Soldering, 10sec)	T _{LEAD}	+300	°C

Note 1: Stresses greater than those listed under "Absolute Maximum Ratings" may cause permanent damage to the device. These are stress ratings only, and functional operation of the device at these or any other conditions beyond those indicated under "Recommended Operating Conditions" is not implied. Exposure to "Absolute Maximum Ratings" for extended periods may affect device reliability.

Note 2: All voltages are with respect to pin 5 and all currents are positive into specified terminal.

Note 3: Board thickness 1.6mm, board dimension 90mm X 90mm.

Recommended Operating Conditions

Parameter	Symbol	Min	Max	Unit
Oscillation Frequency	f		500	KHz
Ambient Temperature	T _A	-40	85	°C

**CURRENT MODE PWM CONTROLLER****AZ3842/3/4/5****Electrical Characteristics**(V_{CC}=15V, R_T=10kΩ C_T=3.3nF, T_A= -40°C to +85°C, unless otherwise specified.)

Parameter	Symbol	Conditions	Min	Typ	Max	Unit
REFERENCE SECTION						
Reference Output Voltage	V _{REF}	T _J =25°C, I _{REF} =1mA	4.90	5.00	5.10	V
Line Regulation	ΔV _{REF}	12V ≤ V _{CC} ≤ 25V		4	15	mV
Load Regulation	ΔV _{REF}	1mA ≤ I _{REF} ≤ 20mA		4	15	mV
Short Circuit Output Current	I _{SC}	T _A =25°C		-100	-180	mA
Temperature Stability				0.2	0.4	mV/°C
Output Noise Voltage		(Note 6)		50		μV
Long Term Stability		T _A =85°C, 1000 hours		5	25	mV
OSCILLATOR SECTION						
Oscillation Frequency	f	T _J =25°C	47	52	57	KHz
Frequency Change with Voltage	Δf/f	12V ≤ V _{CC} ≤ 25V		0.2	1	%
Oscillator Amplitude	V _{OSC}	Pin 4, peak to peak (Note 6)		1.7		V
Temperature Stability		(Note 6)		2.5		%
ERROR AMPLIFIER SECTION						
Input Bias Current	I _{BIAS}	(Note 6)		-0.1	-2	μA
Input Voltage	V _I	V _{pin1} =2.5V	2.42	2.50	2.58	V
Open Loop Voltage Gain	A _{VOL}	2V ≤ V _O ≤ 4V	65	90		dB
Power Supply Rejection Ratio	PSRR	12V ≤ V _{CC} ≤ 25V	60	70		dB
Output Sink Current	I _{SINK}	V _{pin2} =2.7V, V _{pin1} =1.1V	2	4		mA
Output Source Current	I _{SOURCE}	V _{pin2} =2.3V, V _{pin1} =5V	-0.5	-0.8		mA
High Output Voltage	V _{OH}	V _{pin2} =2.3V, R _L =15kΩ to GND	5	6		V
Low Output Voltage	V _{OL}	V _{pin2} =2.7V, R _L =15kΩ to Pin 8		0.8	1.1	V
CURRENT SENSE SECTION						
Gain	GV	(Note 4, 5)	2.85	3	3.15	V/V
Maximum Input Signal	V _{I(MAX)}	V _{pin1} =5V (Note 4)	0.9	1	1.1	V
Power Supply Rejection Ratio	PSRR	12V ≤ V _{CC} ≤ 25V (Note 4, 6)		70		dB
Input Bias Current	I _{BIAS}			-3	-10	μA
Delay to Output		V _{pin3} = 0 to 2V (Note 6)		150	300	ns
OUTPUT SECTION						
Low Output Voltage	V _{OL}	I _{SINK} = 20mA		0.1	0.4	V
		I _{SINK} = 200mA		1.4	2.2	V
High Output Voltage	V _{OH}	I _{SOURCE} = 20mA	13	14		V
		I _{SOURCE} = 200mA	12	13		V
Rise Time	t _R	T _J =25°C, C _L =1nF (Note 6)		50	150	ns

**CURRENT MODE PWM CONTROLLER****AZ3842/3/4/5****Electrical Characteristics (Continued)**

Parameter	Symbol	Conditions	Min	Typ	Max	Unit
Fall Time	t_F	$T_I=25^\circ\text{C}$, $C_I=1\text{nF}$ (Note 6)		50	150	ns
UNDER -VOLTAGE LOCKOUT SECTION						
Start Threshold	$V_{TH(ST)}$	AZ3842/AZ3844	14.5	15.5	16.5	V
		AZ3843/AZ3845	7.8	8.4	9.0	V
Min. Operation Voltage (After Turn On)	V_{OPR} (Min.)	AZ3842/AZ3844	8.5	10.0	11.5	V
		AZ3843/AZ3845	7.0	7.6	8.2	V
PWM SECTION						
Max. Duty Cycle	D(Max.)	AZ3842/AZ3843	93	95	100	%
	D(Max.)	AZ3844/AZ3845	46	48	50	%
Min. Duty Cycle	D(Min.)				0	%
TOTAL STANDBY CURRENT SECTION						
Start-Up Current	I_{ST}			0.6	1	mA
Operating Supply Current	$I_{CC(OPR)}$	$V_{pin3}=V_{pin2}=0\text{V}$		10	14	mA
Zener Voltage	V_Z	$I_{CC}=25\text{mA}$	30	34		V
OVER-TEMPERATURE PROTECT SECTION						
Shutdown Temperature	T_{SHUT}	(Note 6)		165		$^\circ\text{C}$
Temperature Hysteresis	T_{HYS}	(Note 6)		25		$^\circ\text{C}$

Note 4: Parameters are tested at trip point of latch with $V_{pin2} = 0$.

Note 5: Here gain is defined as:

$$A = \frac{\Delta V_{Pin 1}}{\Delta V_{Pin 3}}, 0 \leq V_{pin3} \leq 0.8\text{V}$$

Note 6: These parameters, although guaranteed, are not 100% tested in production.

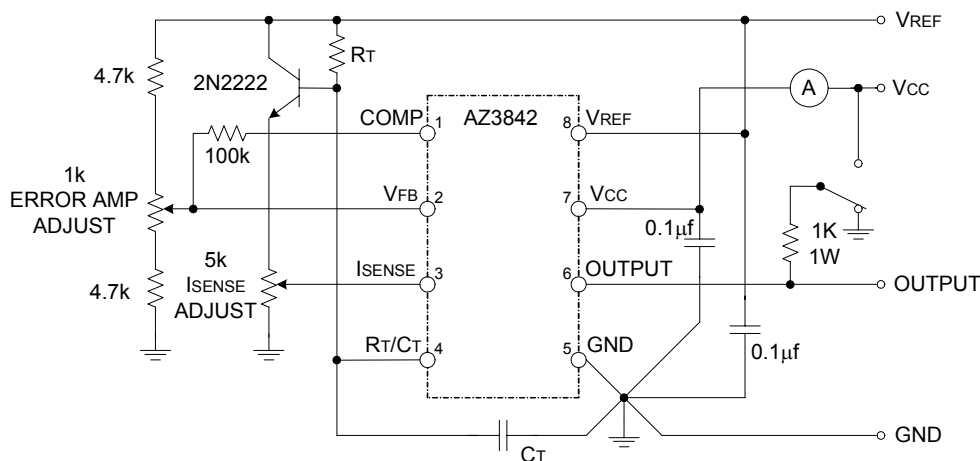


Figure 4. Basic Test Circuit



CURRENT MODE PWM CONTROLLER

AZ3842/3/4/5

Electrical Characteristics (Continued)

Figure 4 is the basic test circuit for AZ384x. In testing, the high peak currents associated with capacitive loads necessitate careful grounding techniques. Timing and bypass capacitors should be connected close to pin 5 in a single point ground. The transistor and 5k potentiometer are used to sample the oscillator waveform and apply an adjustable ramp to pin 3.

Typical Performance Characteristics

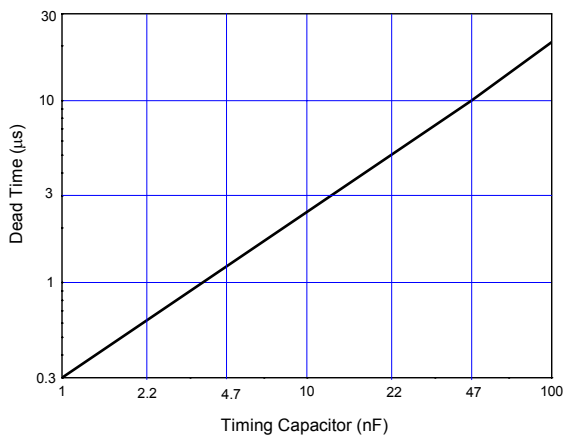


Figure 5. Oscillator Dead Time vs. Timing Capacitor

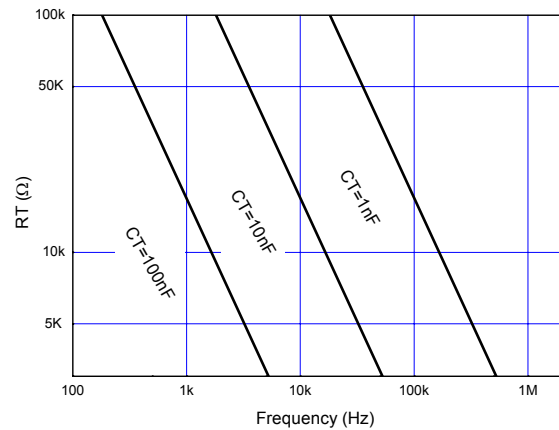


Figure 6. Timing Resistor vs. Frequency

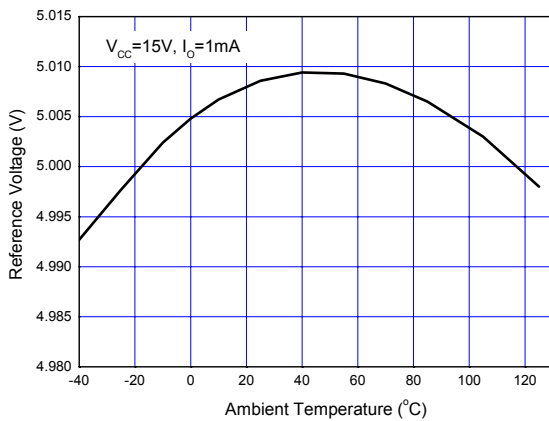


Figure 7. Reference Voltage vs. Ambient Temperature

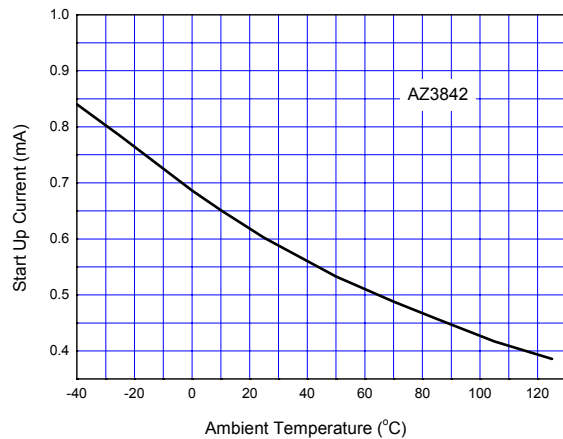


Figure 8. Start-up Current vs. Ambient Temperature

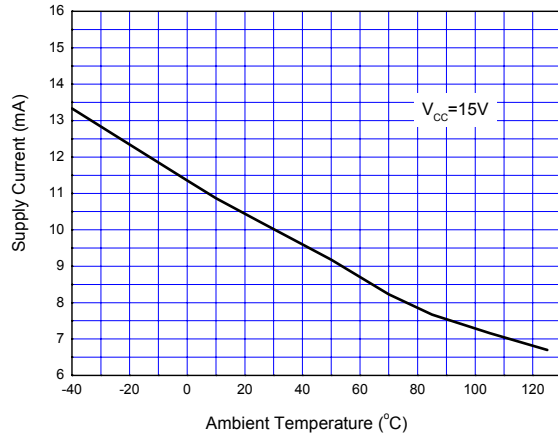
**CURRENT MODE PWM CONTROLLER****AZ3842/3/4/5****Typical Performance Characteristics (Continued)**

Figure 9. Supply Current vs. Ambient Temperature

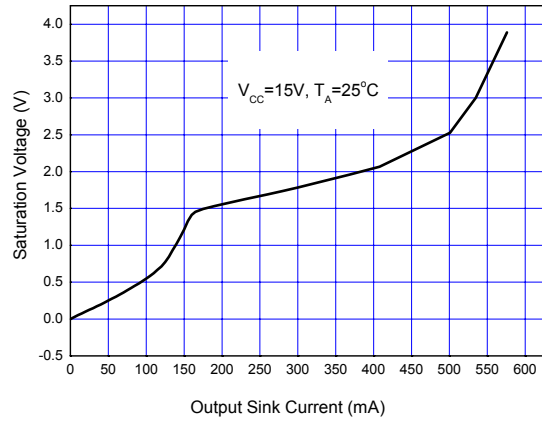


Figure 10. Output Saturation Characteristics

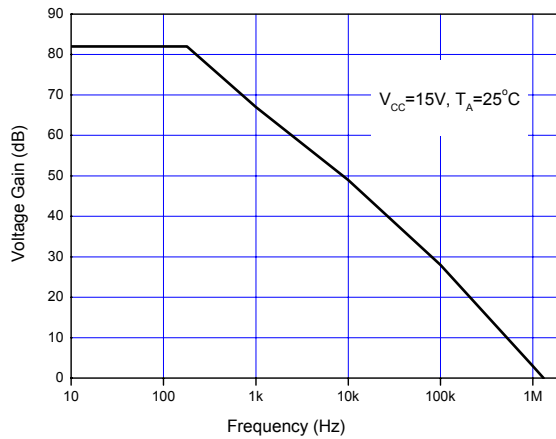


Figure 11. Error Amplifier Open-loop Frequency Response



CURRENT MODE PWM CONTROLLER

AZ3842/3/4/5

Typical Application

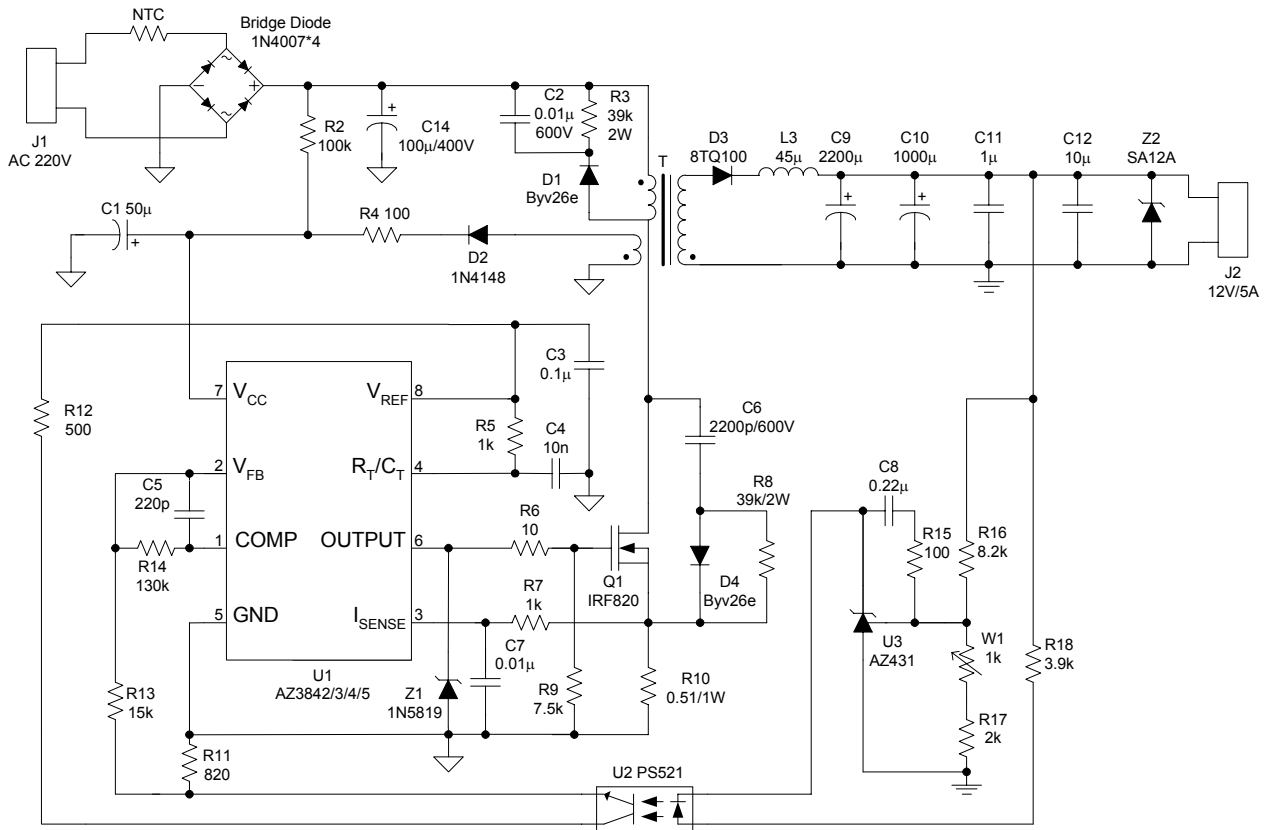


Figure 12. Typical Application of AZ3842/3/4/5

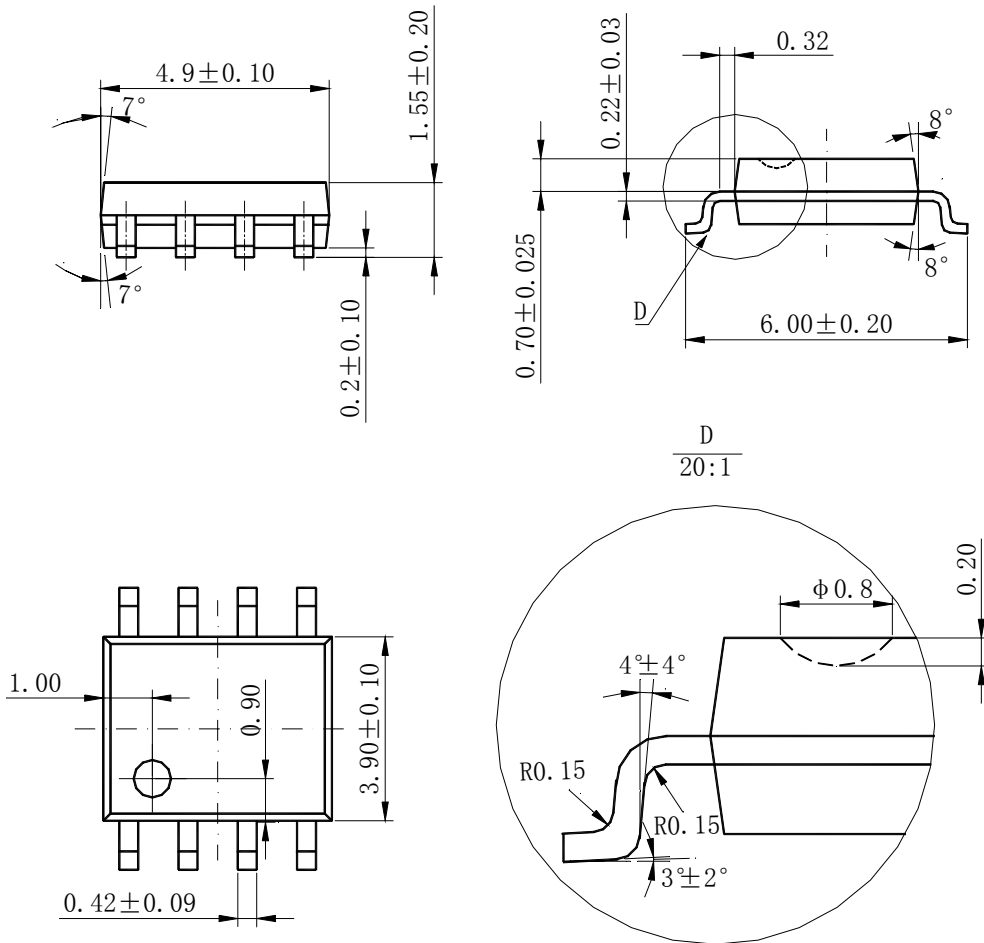


CURRENT MODE PWM CONTROLLER

AZ3842/3/4/5

Mechanical Dimensions

SOIC-8



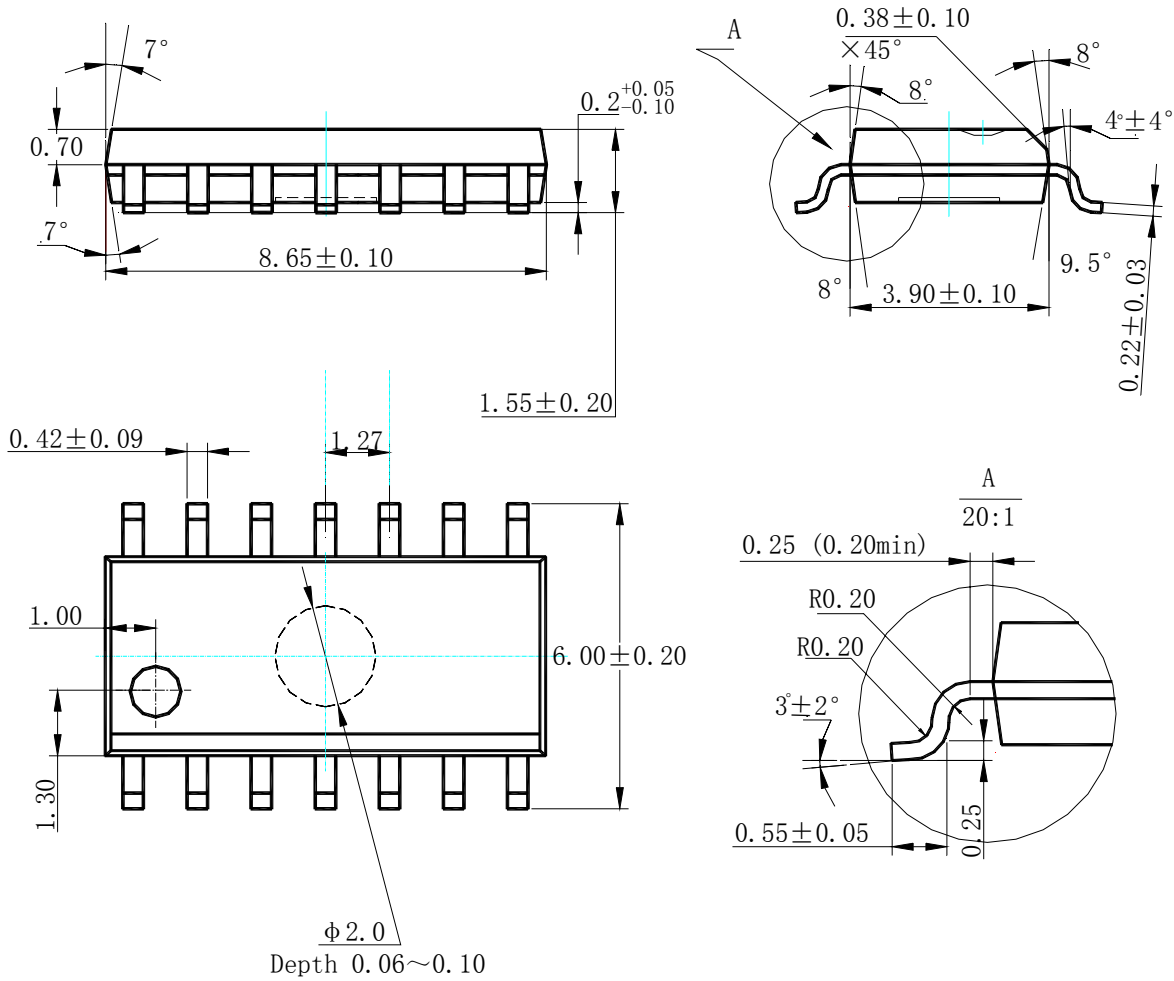


CURRENT MODE PWM CONTROLLER

AZ3842/3/4/5

Mechanical Dimensions (Continued)

SOIC-14



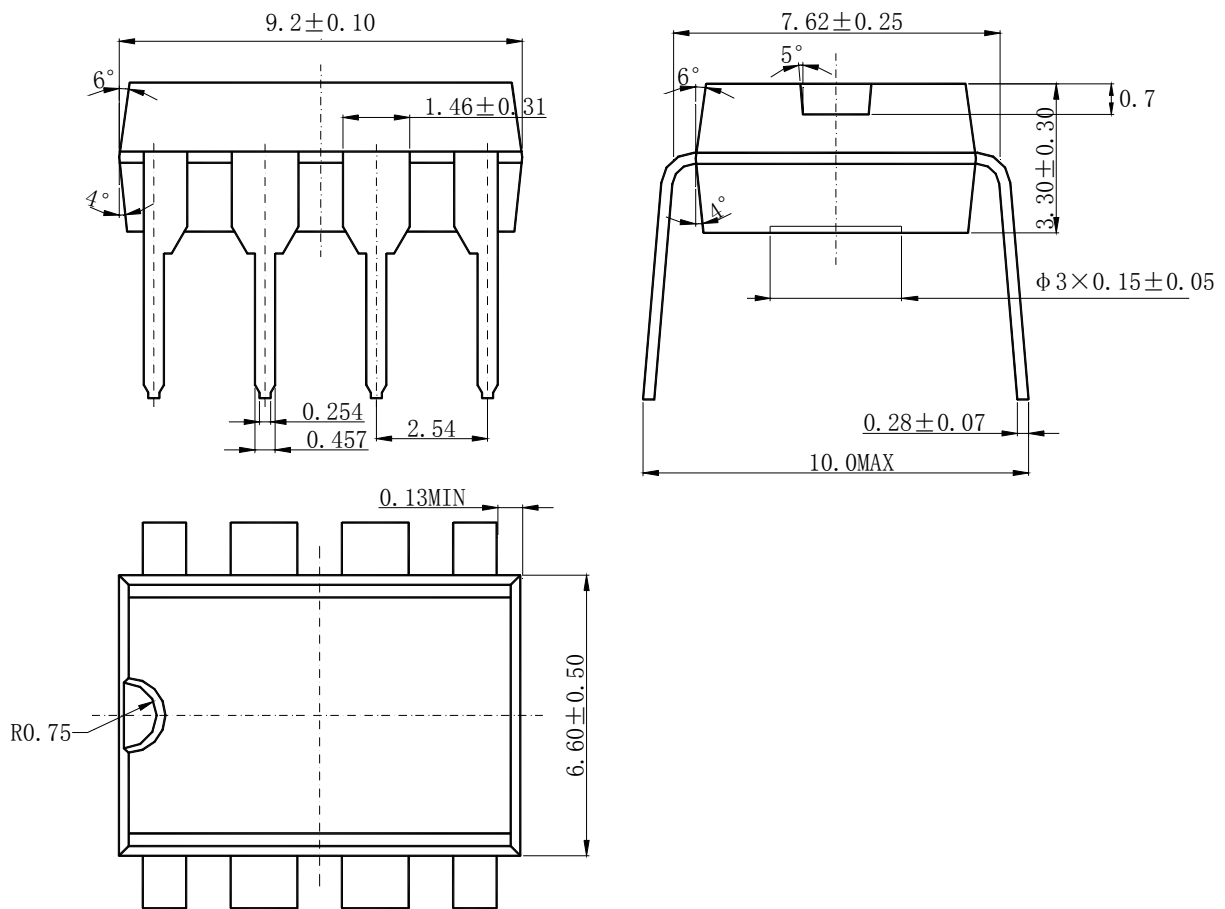


CURRENT MODE PWM CONTROLLER

AZ3842/3/4/5

Mechanical Dimensions (Continued)

DIP-8





<http://www.aacmicro.com>

USA: 860 Hillview Court, Suite 160, Milpitas, CA 95035, USA

Tel: 408-586 8809, Fax: 408-586 8801

China: 8th Floor, Zone B, 900 Yi Shan Road, Shanghai 200233, China

Tel: 86-21-6495 9539, Fax: 86-21-6485 9673

Taiwan: Room 2210, 22nd Fl, 333, Keelung Road, Sec. 1, Taipei 110, Taiwan

Tel: 886-2-2758 6828, Fax: 886-2-2758 6892

IMPORTANT NOTICE

Advanced Analog Circuits Corporation reserves the right to make changes to its products or specifications at any time, without notice, to improve design or performance and to supply the best possible product. Advanced Analog Circuits does not assume any responsibility for use of any circuitry described other than the circuitry embodied in Advanced Analog Circuits' products. The company makes no representation that circuitry described herein is free from patent infringement or other rights of Advanced Analog Circuits Corporation.