

3D Low Power Wake-up Receiver AS3931

PRODUCT BRIEF

1. General Description

AS3931 is an ultra low power, three channel LF ASK receiver designed to operate in various applications such as LF identification systems and LF tag receivers. AS3931 is able to detect a low frequency ASK-modulated signal by looking for a digital wake-up pattern and generates a WAKE signal after successful pattern detection. The device incorporates an intelligent pattern detection algorithm that provides reliable operation even in presence of strong interferences. RSSI signals can be generated at the RSSI pin for each receiver channel.

2. Key Features

- 3D wake-up pattern detection
- 3D LF field strength measurement
- Antenna rotation for easy calibration
- High sensitivity and high dynamic range
- Wide operating frequency range
- Reliable, interference resistant wake-up decoding
- Highly protected differential inputs
- Ultra low power consumption

3. Main characteristics

- Wake-up sensitivity: **350 μ Vpp**
- LF carrier frequency range: **19 – 150 kHz**
- Data rate: **2.731 kb/s**
- Current consumption in standby mode: **6.6 μ A**
- Dynamic range: **60 dB**
- RSSI step: (ΔV_{RSSI} @ 1 mVpp input amp.): **290 mV**

4. Additional Features

- Antenna rotation switch
- three independent LF receiver chains
- Wake-up output combining the three receiver chains
- Low power 32.768 kHz crystal oscillator circuit
- Serial programming interface
- Voltage regulator with 2.4 V output, on/off switchable

Each independent LF receiver chain contains:

- Input overload protection
- Input attenuator
- Ultra low power LF amplifier with logarithmic envelope output
- Robust data detector with adaptive slicing threshold that translates the logarithmic envelope into a digital data signal
- Error tolerant digital pattern correlator that detects a given code sequence in the received data signal and generates a wake-up signal
- Sophisticated power management logic that powers down the correlator if no data is received

5. Applications

- LF identification systems
- LF tag receivers
- Three-dimensional LF field strength measurement systems
- Ultra low power wake-up systems

Block Diagram AS3931

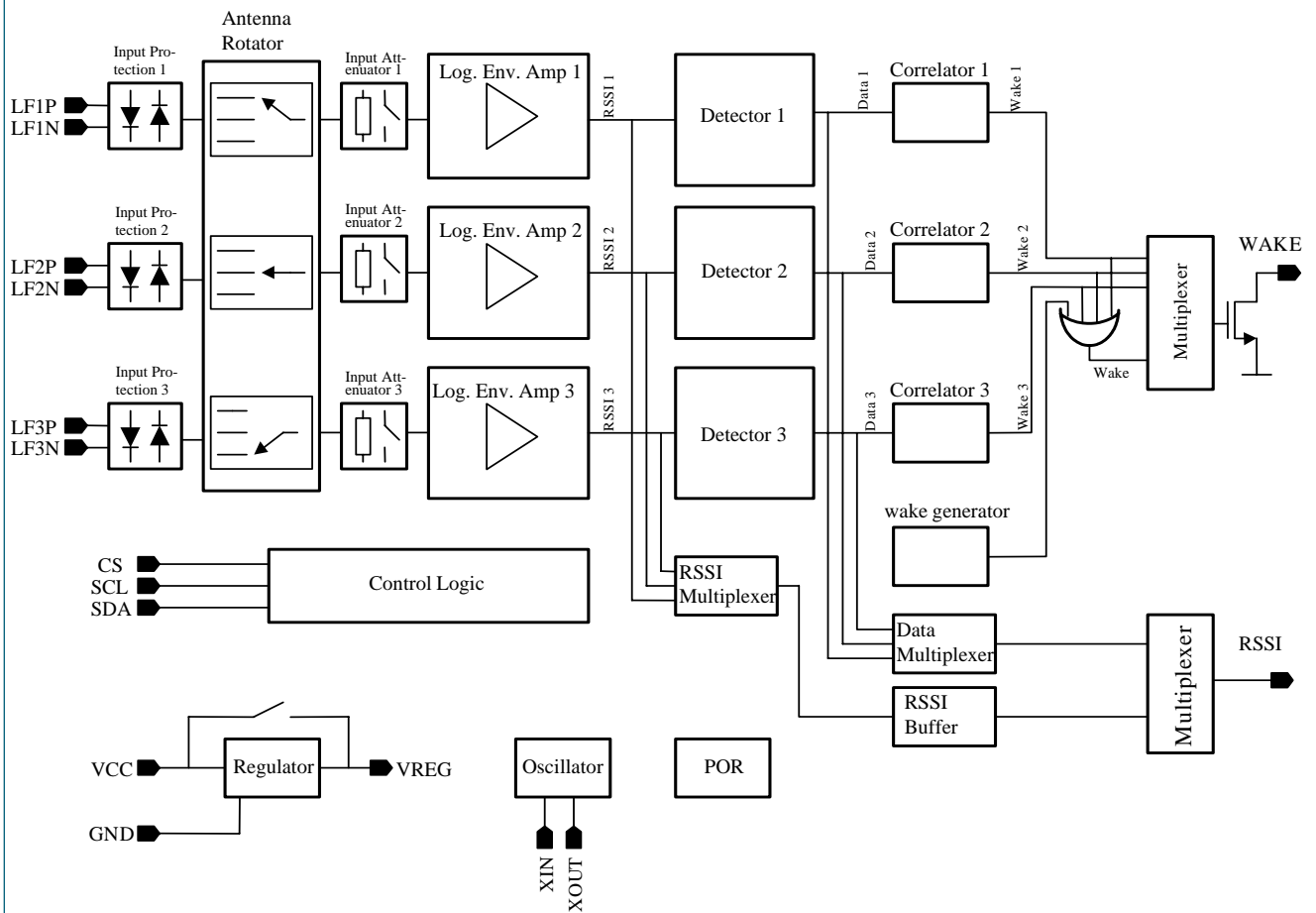

Package, Pin-out and Marking

16 pin TSSOP package

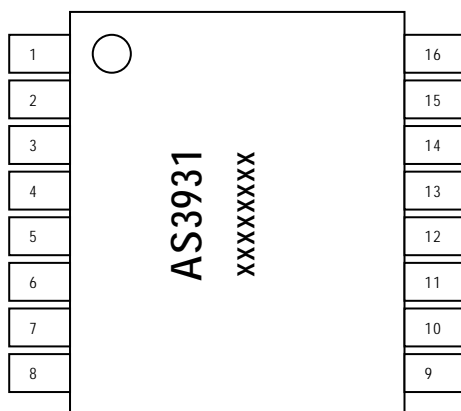

1	VCC	16	VREG
2	LF1N	15	RSSI
3	LF1P	14	SDA
4	LF2N	13	SCL
5	LF2P	12	CS
6	LF3N	11	WAKE
7	LF3P	10	XOUT
8	GND	9	XIN

xxxxxxx = Date Code and Plant ID