

# RATIOMETRIC VOLTAGE TRANSMITTER AM417

## FEATURES

- Supply Voltage  $5V \pm 5\%$  (Ratio Range)
- Wide Operating Temperature Range:  $-40^{\circ}\text{C} \dots +100^{\circ}\text{C}$
- Ratiometrical Current Source for Transducer Excitation
- Instrumentation Amplifier Input
- Voltage Output Driver  
Open Collector:  
 $V_{OUT} = 0.5-4.5V$   
 $I_{OUT} = +10\text{mA}$
- Adjustable Gain, Offset, and Output Voltage Range
- Small Package Dimensions: SO8
- Low Cost

## APPLICATIONS

- Industrial Process Control
- Automotive Applications
- Sensor Transmitter

## GENERAL DESCRIPTION

The AM417 is a low cost ratiometrical voltage transmitter, designed for flexible bridge input signal conditioning. The IC contains a ratiometric current source for transducer excitation, a high accuracy instrumentation amplifier for differential input signals, and a voltage output driver. Gain, offset, and output voltage range are adjustable by external resistors. The voltage output stage is designed as an open collector stage. The output current is +10mA. A simple current limitation is possible by adding an external resistor. With its functional blocks and possibilities to adjust all important parameters for sensor calibration, the small package dimensions (SO8), and the low costs the AM417 is ideally suited for automotive sensor interface applications.

## DELIVERY

- DIL8 packages (samples)
- SOP8 packages
- Dice on 5" blue foil

## BLOCK DIAGRAM

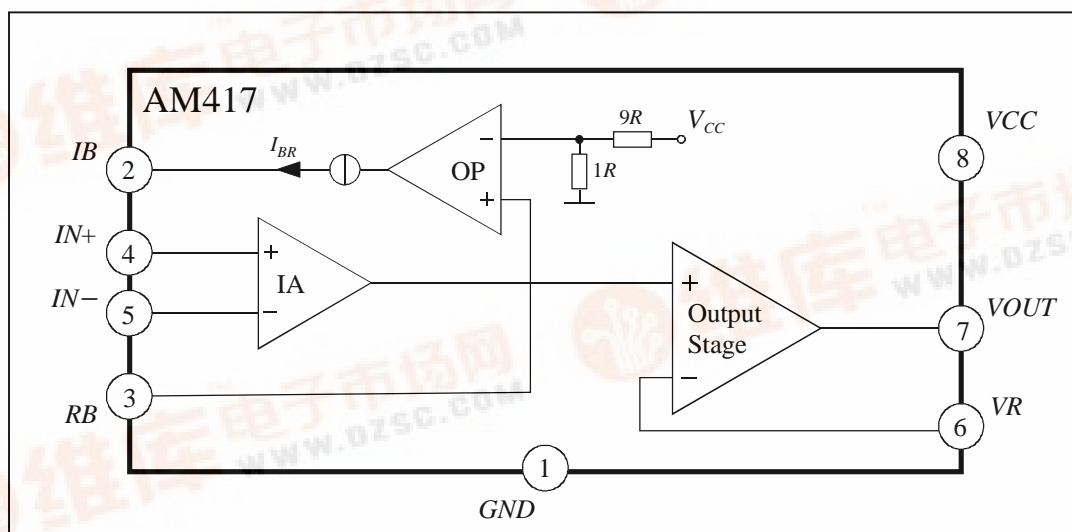

Figure 1

# RATIOMETRIC VOLTAGE TRANSMITTER      AM417

## ELECTRICAL SPECIFICATIONS

$T_{amb} = 25^{\circ}\text{C}$ ,  $V_{CC} = 5\text{V}$  (unless otherwise noted)

Parameter	Symbol	Conditions	Min.	Typ.	Max.	Unit
Voltage Range (Ratio Range)	$V_{CC}$		4.75	5	5.25	V
Maximum Supply Voltage	$V_{CCmax}$				6	V
Quiescent Current	$I_{CC}$	$R_{RB} = 500\Omega$ , $I_{IB} = 1\text{mA}$			6.2	mA
<b>Temperature Specifications</b>						
Operating	$T_{amb}$		-40		100	$^{\circ}\text{C}$
Storage	$T_{st}$		-55		125	$^{\circ}\text{C}$
Junction	$T_J$				150	$^{\circ}\text{C}$
Thermal Resistance	$\Theta_{ja}$	DIL8 plastic package		110		$^{\circ}\text{C}/\text{W}$
	$\Theta_{ja}$	SO8 plastic package		180		$^{\circ}\text{C}/\text{W}$
<b>Ratiometric Current Source – Transducer</b>						
Internal Sense Voltage	$V_{RB}$	ratiometric with $V_{CC}$ , $V_{VCC} = 5\text{V}$		0.5		V
Output Current Range	$I_{IB}$		0.50		1.25	mA
Output Current	$I_{IB}$	ratiometric with $V_{CC}$ , $R_{RB} = 500\Omega$ , $V_{VCC} = 5\text{V}$	0.98	1	1.02	mA
Ratiometric Error	$RAT@IB$	$V_{VCC} = 5.25\text{V}$ , $RAT@IB = 1.05 V_{RB} (V_{VCC} = 5\text{V})$ $- V_{RB} (V_{VCC} = 5.25\text{V})$			$\pm 1$	mV
$I_{RB}$ vs. Temperature	$dI_{RB}/dT$	$I_{IB} = 1\text{mA}$			$\pm 20$	ppm/ $^{\circ}\text{C}$
Output Voltage Range	$V_{IB}$	$I_{IB} = 1.25\text{mA}$	1.5		$V_{CC}-0.5$	V
Output Resistance	$R_{IB}$	$I_{IB} = 1\text{mA}$ , $R_{IB} = \Delta U_{IB}/\Delta I_{IB}$ , $V_{VIB} = 5\text{V}$ , $I_{IB} = 1\text{mA}$	1.5	4.5		M $\Omega$
Power Supply Rejection Ratio	$\Delta I_{IB}$	$\Delta V_{CC} = 4.75\text{V} - 5.25\text{V}$ , $V_{VIB} = 5\text{V}$ , $I_{IB} = 1\text{mA}$	76	90		dB
<b>Instrumentation Amplifier</b>						
Input Voltage Range	$V_{IN+/-}$		1.5		$V_{CC}-2$	V
Internal Gain	$G_{IA}$	$V_{IN-} = 2\text{V}$ , $\Delta V_{IN} = 200\text{mV}$ $G_{IA} = \Delta V_{VIA}/\Delta V_{IN}$	9.8	10.0	10.2	
Common Mode Rejection Ratio	$CMRR$		80	90		dB
Power Supply Rejection Ratio	$PSRR$		74	80		dB
Offset Voltage	$V_{OS}$				$\pm 3$	mV
$V_{OS}$ vs. Temperature	$dV_{OS}/dT$				$\pm 10$	$\mu\text{V}/^{\circ}\text{C}$
Input Bias Current	$I_B$	$V_{IN} = 2\text{V}$		25	75	nA
Output Voltage Range	$V_{VIA}$		0		$V_{CC}-2$	V
Output Resistance	$R_{OUT}$			20		k $\Omega$
Nonlinearity		$\Delta V_{IN} = 200\text{mV}$ , ideal input			0.1	% FS
<b>Voltage Output Stage</b>						
Adjustable Gain	$G_{OUT}$		2		11	
Input Voltage Range	$V_{VR}$		0		$V_{CC}-2.5$	V
Power Supply Rejection Ratio	$PSSR$		-72	-90		dB
Offset Voltage	$V_{OS}$				$\pm 3.0$	mV
$V_{OS}$ vs. Temperature	$dV_{OS}/dT$	$\Delta V_{IN} = 50\text{mV}$			$\pm 15$	$\mu\text{V}/^{\circ}\text{C}$
Input Current	$I_{IN}$	$\Delta V_{IN} = 50\text{mV}$		20	75	nA
Output Voltage Range	$V_{OUT}$	with transistor BCW68H $I_{OUT} = 10\text{mA}$ (see figure 5)	0.5		4.5	V

# RATIOMETRIC VOLTAGE TRANSMITTER

# AM417

Parameter	Symbol	Conditions	Min.	Typ.	Max.	Unit
<b>Voltage Output Stage (cont.)</b>						
Output Current	$I_{OUT}$	with transistor BCW68H			12.5	mA
Output Current Pin $V_{OUT}$	$I_{V_{OUT}}$	pin $V_{OUT}$	100	200	300	$\mu$ A
Current Limitation Threshold	$V_{THRESH}$	$V_{THRESH} = V_{VCC} - V_{V_{OUT}min}$ , $R_2 = 27\Omega$ , $I_{OUT} \approx 14mA$	120	150	180	mV
$V_{THRESH}$ vs. Temperature	$dV_{THRESH}/dT$	$-40...+100^\circ C$	1.00		1.15	mV
Output Resistance	$R_{OUT}$	virtual		0.1	0.85	$\Omega$
Linearity		ideal input			0.01	%FS

## BOUNDARY CONDITIONS

Parameter	Symbol	Conditions	Min.	Typ.	Max.	Unit
Resistor Adjustment Current Source (Transducer)	$R_1$		400		1000	$\Omega$
Gain Resistor Sum	$R_3 + R_4$				2.0	k $\Omega$
Capacitor Power Supply	$C_1$		100			nF
Capacitor Frequency Compensation (Output Stage)	$C_2$		4.3		5.8	nF
Capacitor Load (Output Stage)	$C_3$		1.0		10.0	nF
Resistor Sense Current Limitation	$R_2$		0		50	$\Omega$

## FUNCTIONAL DIAGRAM

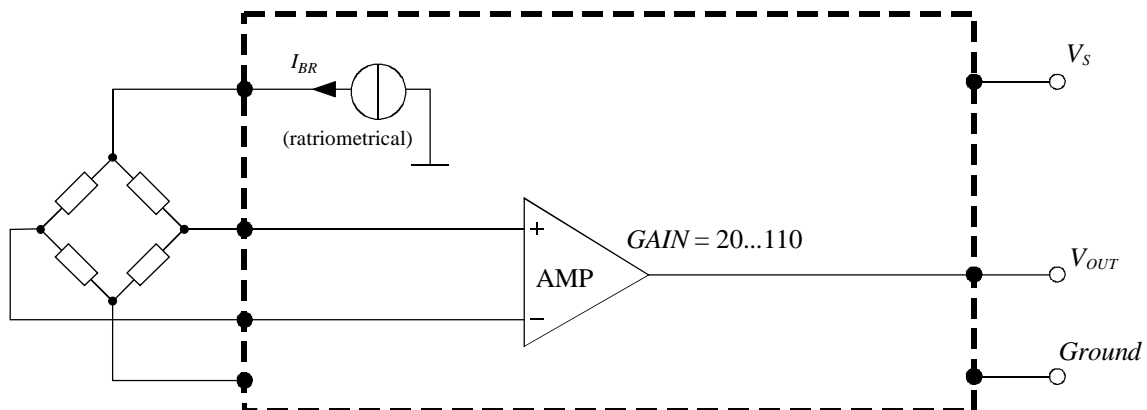

Figure 2

# RATIOMETRIC VOLTAGE TRANSMITTER AM417

## FUNCTIONAL DESCRIPTION

The AM417 is an integrated low cost ratiometric voltage transmitter specially designed for bridge input signals in automotive applications. With its integrated, ratiometrical current source the AM417 is ideally suited for the signal conditioning of piezoresistive pressure transducers and allows an easy temperature compensation and span adjustment of a these kinds of sensors.

The AM417 consists of 3 basic functional blocks:

1. A **Ratiometrical Current Source** for transducer excitation:

The current  $I_{IB}$  can be adjusted by the variation of the resistor  $R_1$  by the following relation:

$$I_{IB} = \frac{V_{VCC}}{10R_1}$$

2. An **Instrumentation Amplifier Input Stage** with a fixed gain  $G_{IA} = 10$  for pre-amplifying the bridge input signal.

3. An **Open Collector Output Stage** with the following functions:

- **Voltage Output:** As output is used a voltage amplifier which has an external PNP–open collector stage  $T_1$  which is able to push a maximum current of  $I_{OUT} = 5\text{mA}$ . The gain  $G_{OUT}$  is adjustable by the external resistors  $R_3$  and  $R_4$  between  $G_{OUT} = 2\dots 11$ :

$$G_{OUT} = \frac{R_3}{R_3 + R_4}$$

The gain  $G$  of the complete system becomes then  $G = G_{IA} G_{OUT}$ .

- **Current Limitation:** A simple clamp stage for the output pin  $V_{OUT}$  limits the voltage drop against  $V_{CC}$  to

$$V_{OUT\max} = V_{VCC} - 1.5V_{BE}(T_1).$$

The maximum current can be set by adding a resistor in series to the Emitter of the transistor  $T_1$  at the output stage (see figure 4). For the maximum output current is valid:

$$I_{OUT\max} = \frac{V_{TRESH} - V_{BE}(T_1)}{R_2} \approx \frac{370\text{mV}}{R_2}.$$

If no current limitation is required, the Emitter of the transistor  $T_1$  has to be directly connected to  $V_{CC}$  ( $R_2 = 0\Omega$ ). A proper thermic coupling of the Transistor  $T_1$  ( $V_{BE}$ -Drift:  $-2\text{mV}/^\circ\text{C}$  typ.) and the AM417 reduces the resulting temperature drift of  $I_{OUT}$  and increases the performance of the current limitation.

## Adjustment of Output Voltage Range

The span of the output voltage could be adjusted by the gain  $G_{OUT}$  of the output stage. The offset of the output voltage can be adjusted in the same way as the adjustment of the sensor offset using the resistors  $R_{O1}$  and  $R_{O2}$  (figure 4).

# RATIOMETRIC VOLTAGE TRANSMITTER AM417

## PINOUT

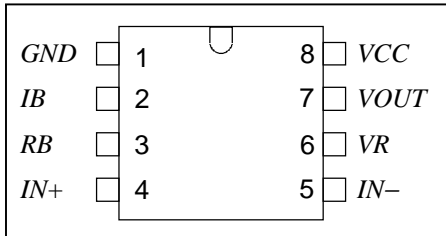

Figure 3

PIN	NAME	DESIGNATION
1	<i>GND</i>	IC Ground
2	<i>IB</i>	Output Current Source
3	<i>RB</i>	Adjustment Current Source
4	<i>IN+</i>	Input Positive
5	<i>IN-</i>	Input Negative
6	<i>VR</i>	Adjustment Gain Output Stage
7	<i>VOUT</i>	Out Output Stage
8	<i>VCC</i>	Supply Voltage

## DELIVERY

The AM417 is available in:

- 8 pin DIL packages (samples)
- SO 8 packages
- Dice on 5" blue foil

## PACKAGE DIMENSIONS SOP8

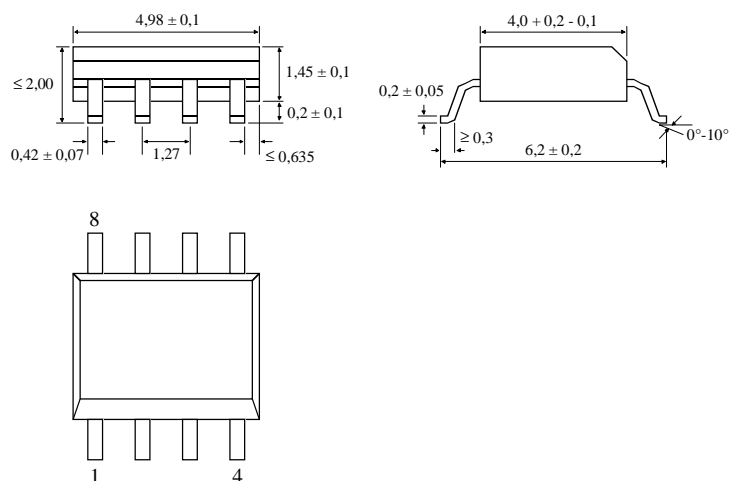

Figure 4

# RATIOMETRIC VOLTAGE TRANSMITTER

# AM417

## APPLICATION FOR OUTPUT VOLTAGE 0.5...4.5V

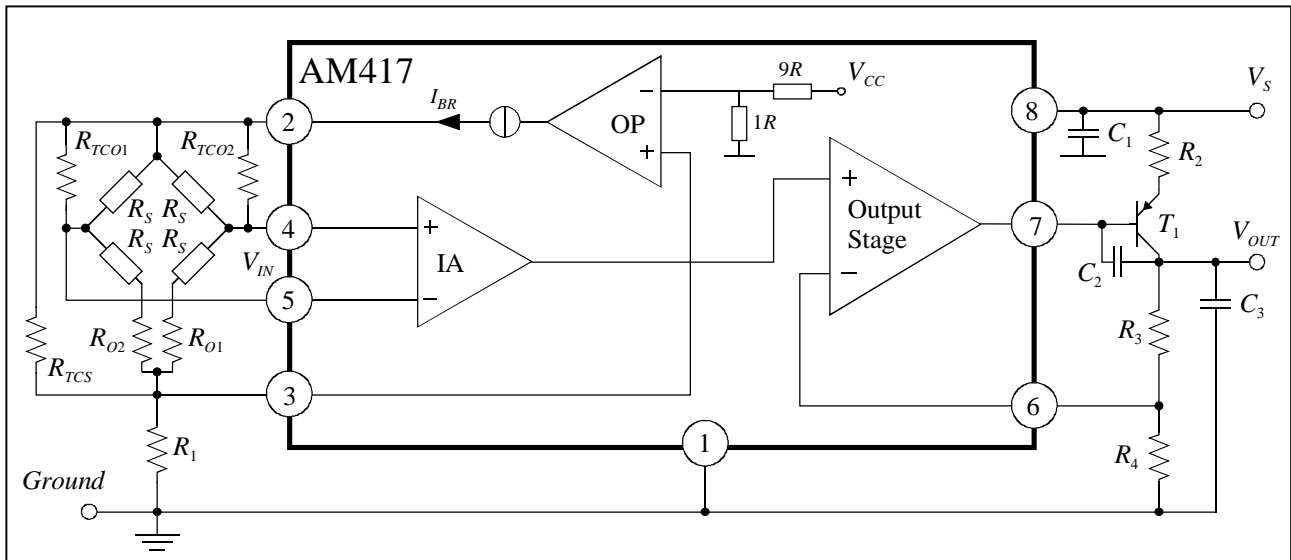

Figure 5

The current application shows the basic functions of the AM417. With the given values of the external components (see *List of External Components*) the following application features are adjusted:

- $V_{IN} = 100\text{mV}$
- $G = G_{IA} G_{OUT} = 40$
- $V_{OUT} = 0.5 - 4.5\text{V}$
- $I_{OUT} = +10\text{mA} - 0.25\text{mA}$
- $I_{BR} = 1\text{mA}$  (ratiometrical supply current for the pressure transducer)

## LIST OF EXTERNAL COMPONENTS

Symbol	Description	Value	Unit
$T_1$	BCW68H, BC557C (or similar)	low drop, high $\beta$ at 10mA	PNP
$R_1$	$I_{BR} = 1\text{mA}$	500	$\Omega$
$R_2$	$I_{OUT} = 10\text{mA min (100}^\circ\text{C)}$	15	$\Omega$
$R_3$	} Span (Gain adjustment) $V_{OUT} = R_3 / (R_3 + R_4) G$	500	$\Omega$
$R_4$		1.5	k $\Omega$
$R_5$	typical transducer resistor	3.0 (typ.)	k $\Omega$
$R_{TCS}$	TC span compensation	10 - 120	k $\Omega$
$R_{O1}, R_{O2}$	Offset adjustment	0 - 500	$\Omega$
$R_{TCO1}, R_{TCO2}$	TC offset adjustment	0.1 - 10.0	M $\Omega$
$C_1$		330	nF
$C_2$	$\pm 10\%$	4.7	nF
$C_3$	$\pm 10\%$	1.0	nF

The information provided herein is believed to be reliable; however, Analog Microelectronics assumes no responsibility for inaccuracies or omissions. Analog Microelectronics assumes no responsibility for the use of this information, and all use of such information shall be entirely at the user's own risk. Prices and specifications are subject to change without notice. No patent rights or licences to any of the circuits described herein are implied or granted to any third party. Analog Microelectronics does not authorise or warrant any Analog Microelectronics product use in life support devices and/or systems.