

Si photodiode array S4111/S4114 series

16, 35, 46 element Si photodiode array for UV to NIR

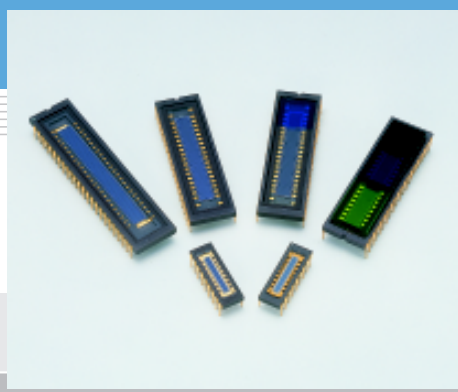

S4111/S4114 series are Si photodiode linear array mounted in ceramic DIPs (Dual Inline Packages). These photodiode arrays are primarily developed for low-light-level detection such as spectrophotometry, and cover a wide spectral range from UV to near infrared light. Since all elements can be used with a reverse bias for charge storage readout, S4111/S4114 series are able to detect low level light with high sensitivity. Cross-talk between elements is minimized to maintain signal purity. Special filters can be attached as the input window.

Features

- Large active area
- Low cross-talk
- Wide spectral response range
- High UV sensitivity
- Wide linearity
- S4111 series: Enhanced infrared sensitivity, low dark current
- S4114 series: Low terminal capacitance, high-speed response

Applications

- Multichannel spectrophotometers
- Color analyzers
- Light spectrum analyzers
- Light position detection

General ratings / Absolute maximum ratings

Type No.	Dimensional outline/ Window material *	Package (mm)	Active area (per 1 element)		Between elements measure (mm)	Between elements pitch (mm)	Number of elements	Absolute maximum ratings				
			Size (mm)	Effective area (mm ²)				Reverse voltage VR Max. (V)	Operating temperature Topr (°C)	Storage temperature Tstg (°C)		
S4111-16Q	①/Q	18 pin DIP	1.45 × 0.9	1.305	0.1	1.0	16	15	-20 to +60	-20 to +80		
S4111-16R	②/R											
S4111-35Q	③/Q	40 pin DIP	4.4 × 0.9	3.96							35	
S4111-46Q	④/Q	48 pin DIP										46
S4114-35Q	③/Q	40 pin DIP										
S4114-46Q	④/Q	48 pin DIP										46

Electrical and optical characteristics (Typ. Ta=25 °C, per 1 element, unless otherwise noted)

Type No.	Spectral response range λ (nm)	Peak sensitivity wavelength λp (nm)	Photo sensitivity S			Dark current Id Max.		Shunt resistance Rsh VR=10 mV		Terminal capacitance Ct		Rise time tr RL=1 kΩ λ=655 nm		NEP λ=λp	
			λp (A/W)	200 nm (A/W)	633 nm (A/W)	VR=10 mV (pA)	VR=10 V (pA)	Min (GΩ)	Typ. (GΩ)	VR=0 V (pF)	VR=10 V (pF)	VR=0 V (μs)	VR=10 V (μs)	VR=0 V (W/Hz ^{1/2})	VR=10 V (W/Hz ^{1/2})
S4111-16Q	190 to 1100	960	0.58	0.08	0.43	5	25	2.0	250	200	50	0.5	0.1	4.4 × 10 ⁻¹⁶	1.7 × 10 ⁻¹⁵
S4111-16R	320 to 1100			-	0.39										
S4111-35Q	190 to 1100			0.08	0.43	10	50	1.0	30	550	120	1.2	0.3	1.3 × 10 ⁻¹⁵	3.1 × 10 ⁻¹⁵
S4111-46Q															
S4114-35Q	190 to 1000			800	0.50	60	300	0.15	2	35	20	0.1	0.05	5.7 × 10 ⁻¹⁵	8.0 × 10 ⁻¹⁵
S4114-46Q															

* Window material R: resin coating, Q: quartz glass

Spectral response

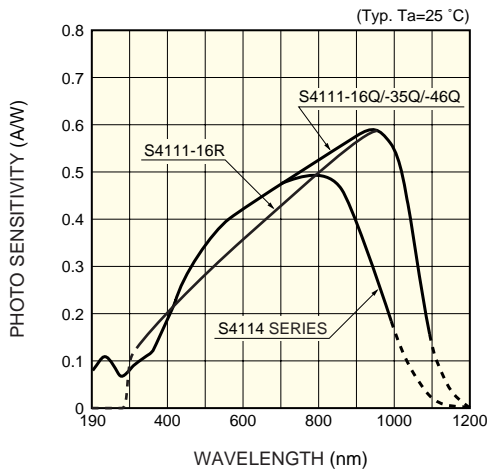
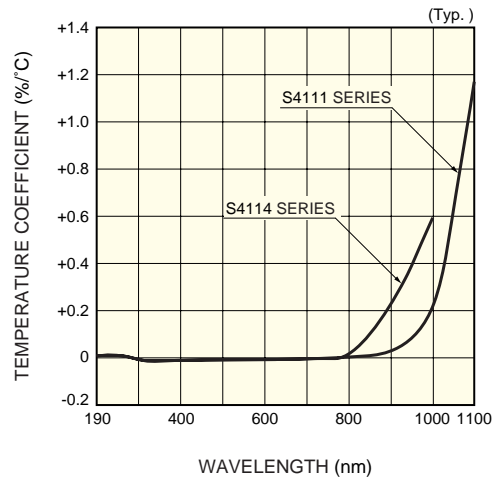
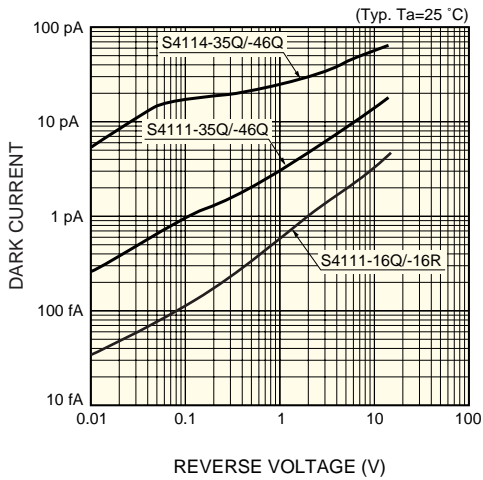

Photo sensitivity temperature characteristics



Dark current vs. reverse voltage



Terminal capacitance vs. reverse voltage

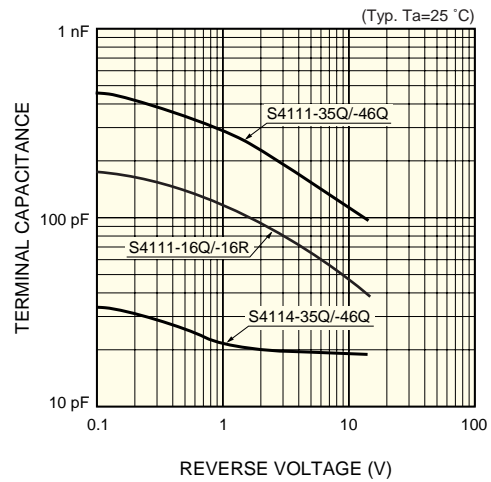

Example of cross-talk

S4111 series

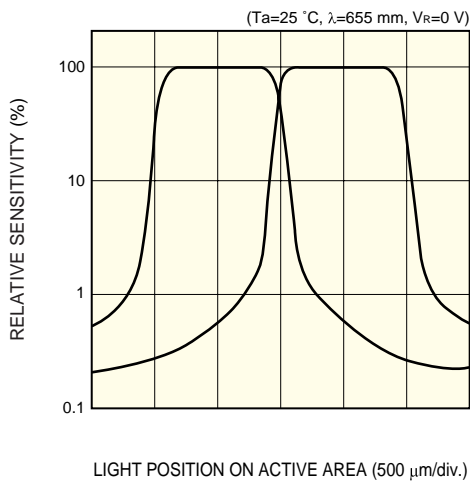

S4114 series

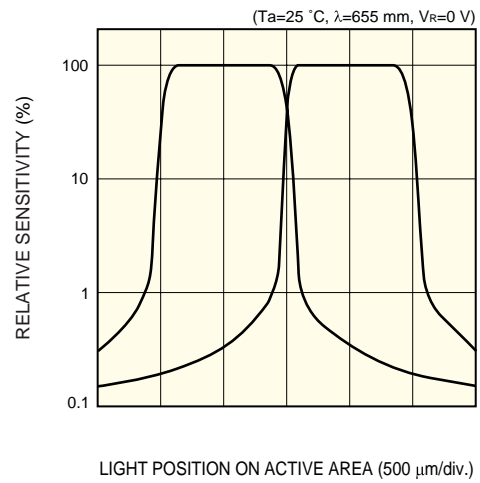

Dimensional outlines (unit: mm)

① S4111-16Q

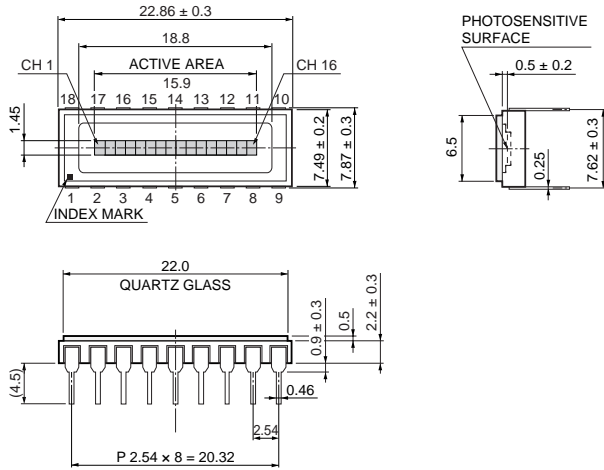

KMPDA0135EA

② S4111-16R

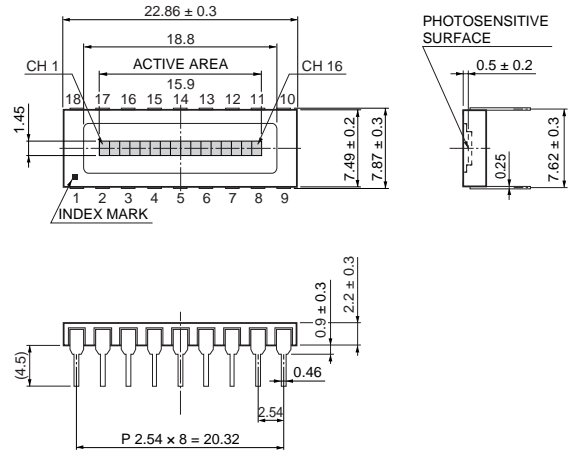

KMPDA0136EA

③ S4111-35Q, S4114-35Q

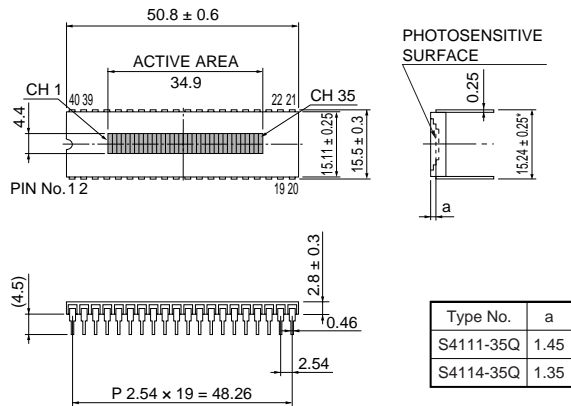

Type No.	a
S4111-35Q	1.45
S4114-35Q	1.35

KMPDA0019EC

④ S4111-46Q, S4114-46Q

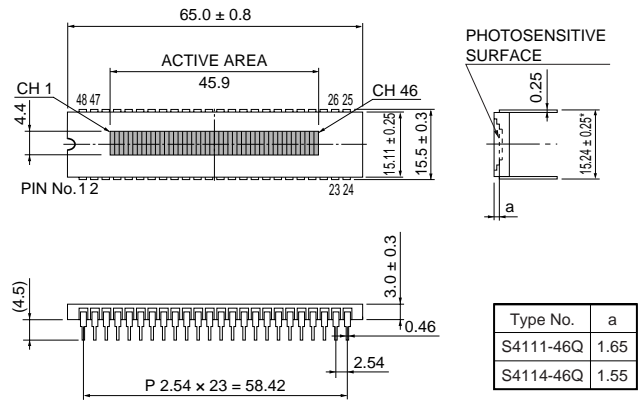

Type No.	a
S4111-46Q	1.65
S4114-46Q	1.55

KMPDA0021EC

Details of elements (for all types)

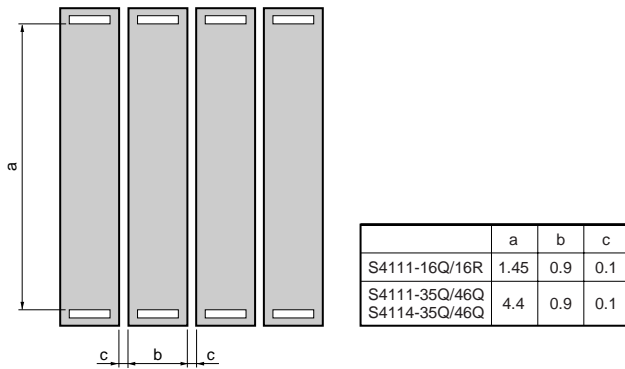

KMPDA0112EA

■ Pin connections

Pin No.	16-element type	35-element type	46-element type
1	KC	KC	KC
2	2	2	2
3	4	4	4
4	6	6	6
5	8	8	8
6	10	10	10
7	12	12	12
8	14	14	14
9	16	16	16
10	KC	18	18
11	15	NC	20
12	13	20	22
13	11	22	24
14	9	24	26
15	7	26	28
16	5	28	30
17	3	30	32
18	1	32	34
19		34	36
20		NC	38
21		KC	40
22		35	42
23		33	44
24		31	46
25		29	KC
26		27	45
27		25	43
28		23	41
29		21	39
30		19	37
31		17	35
32		15	33
33		13	31
34		11	29
35		9	27
36		7	25
37		5	23
38		3	21
39		1	19
40		NC	17
41			15
42			13
43			11
44			9
45			7
46			5
47			3
48			1

■ Operating circuits

- ① In the most generally used circuit, operational amplifiers are connected to each channel to read the output in real time. The output of an operational amplifier is of low impedance and thus can be easily multiplexed.

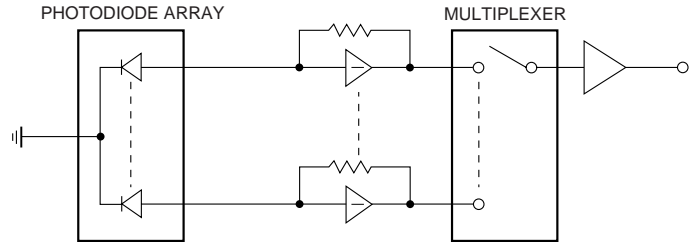

KMPDC0001EA

- ② In the charge storage readout method, the charge stored in the junction capacitance of each channel, which is proportional to the incident light intensity, can be read out in sequence by a multiplexer. With this method, reverse voltage must be applied to the photodiodes, so S4111 and S4114 series are suitable. One amplifier is sufficient but care should be taken regarding noise, dynamic range, etc.

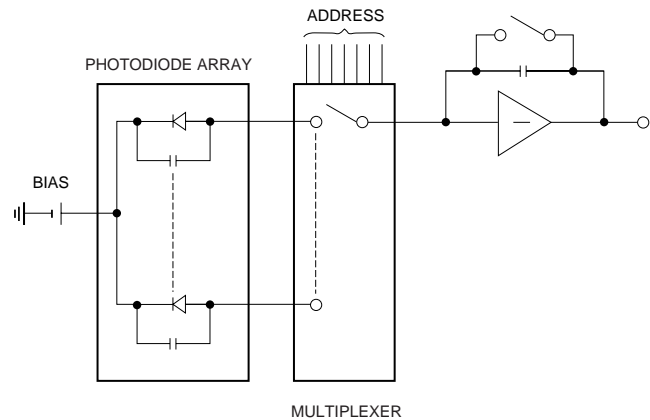

KMPDC0002EA

HAMAMATSU

Information furnished by HAMAMATSU is believed to be reliable. However, no responsibility is assumed for possible inaccuracies or omissions. Specifications are subject to change without notice. No patent rights are granted to any of the circuits described herein. ©2006 Hamamatsu Photonics K.K.

HAMAMATSU PHOTONICS K.K., Solid State Division

1126-1 Ichino-cho, Hamamatsu City, 435-8558 Japan, Telephone: (81) 53-434-3311, Fax: (81) 53-434-5184, www.hamamatsu.com

U.S.A.: Hamamatsu Corporation: 360 Foothill Road, P.O.Box 6910, Bridgewater, N.J. 08807-0910, U.S.A., Telephone: (1) 908-231-0960, Fax: (1) 908-231-1218

Germany: Hamamatsu Photonics Deutschland GmbH: Arzbergerstr. 10, D-82211 Herrsching am Ammersee, Germany, Telephone: (49) 08152-3750, Fax: (49) 08152-2658

France: Hamamatsu Photonics France S.A.R.L.: 19, Rue du Saule Trapu, Parc du Moulin de Massy, 91882 Massy Cedex, France, Telephone: 33-(1) 69 53 71 00, Fax: 33-(1) 69 53 71 10

United Kingdom: Hamamatsu Photonics UK Limited: 2 Howard Court, 10 Tevin Road, Welwyn Garden City, Hertfordshire AL7 1BW, United Kingdom, Telephone: (44) 1707-294888, Fax: (44) 1707-325777

North Europe: Hamamatsu Photonics Norden AB: Smidesvägen 12, SE-171 41 Solna, Sweden, Telephone: (46) 8-509-031-00, Fax: (46) 8-509-031-01

Italy: Hamamatsu Photonics Italia S.R.L.: Strada della Moia, 1/E, 20020 Arese, (Milano), Italy, Telephone: (39) 02-935-81-733, Fax: (39) 02-935-81-741