

CH7023/CH7024 TV Encoder

Features

- TV encoder targeting handheld and similar systems
- Support for NTSC, PAL
- Video output support for CVBS or S-video
- Macrovision™ 7.1.L1 copy protection support for SDTV (CH7023 only)
- Programmable 24-bit/18-bit/16-bit/15-bit/12-bit/8-bit digital input interface supporting various RGB and YCrCb (e.g. RGB565, RGB666, RGB888, ITU656 like YCrCb, etc.) input data formats
- Support for input resolutions up to 720x480 and 720x576 (e.g. 220x176, 320x240, 640x480, 720x480, 720x576, etc.)
- Adjustable brightness, contrast, hue and saturation.
- Detect TV / Monitor connection
- Two high quality 10-bit video DAC outputs
- Fully programmable through serial port
- Flexible pixel clock frequency from graphics controller (2.3MHz—64MHz)
- Flexible input clock on the crystal or oscillator (2.3MHz—64MHz)
- Flexible up and down scaling on the display
- Master and slave mode
- Offered in 48-pin LQFP and 49-pin TFBGA Package
- IO voltage and SPC/SPD from 1.2V to 3.3V
- Programmable power management
- Power down current less than 20uA typical
- Power consumption of <150mW for one CVBS output, single terminated and <350mW for two DAC outputs, double terminated.

General Description

The CH7023/CH7024 is a TV encoder device targeting handheld, portable video applications such as digital still cameras and similar portable embedded systems. The device is able to encode the video signals and generate synchronization signals for NTSC and PAL standards.

Supported TV output formats are NTSC-M, NTSC-J, NTSC-433, PAL-B/D/G/A/I, PAL-M, PAL-N and PAL-60.

The device accepts different data formats including RGB and YCrCb (e.g. RGB565, RGB666, RGB888, ITU656 like YCrCb, etc.) via 24 bit/18 bit/15 bit /12 bit /8 bit multiplexed digital inputs. Most embedded controllers are supported. The I/O interface voltage between CH7023/CH7024 and digital video source controller can be selected by the I/O supply voltage (VDDIO). The I/O supply voltage range is from 1.2V to 3.3V. The digital input voltage will follow the I/O supply voltage.

CH7023/CH7024 is offered in both 48-pin LQFP package (7 x 7 mm) and 49-pin TFBGA package (6 x 6 mm). CH7023/CH7024 48-pin LQFP package comes with fixed single serial port address while 49-pin TFBGA package provide two user selectable serial port addresses via AS pin pull up or pull down option. Refer to application note AN-98 for more information.

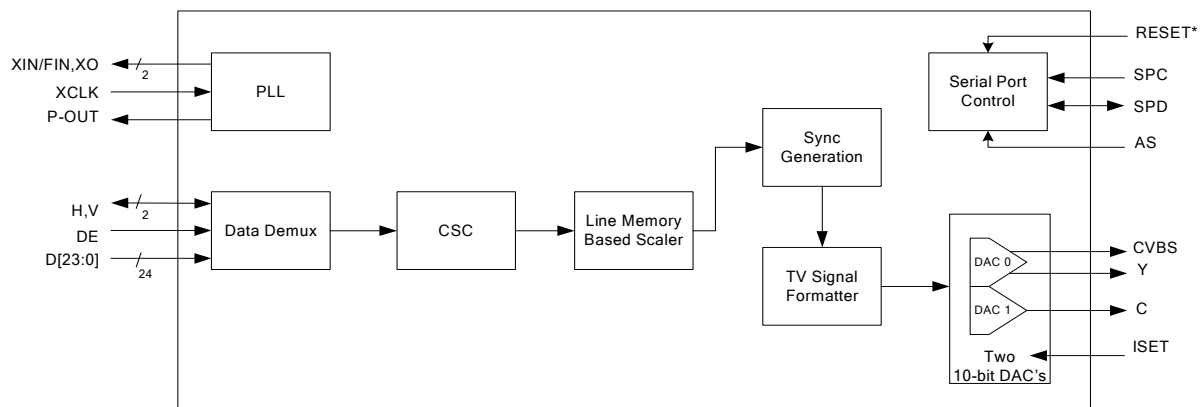

Figure 1: CH7023/CH7024 Block Diagram

1.0 PIN-OUT

There are two major differences between CH7023/CH7024 48-pin LQFP and 49-pin TFBGA in pin-out: the video DACs output and the serial port address option using AS pin.

The CH7023/CH7024 48-pin LQFP comes with three video output pins, primary CVBS (pin 28), S-video Y (pin 27) and secondary CVBS or S-video C (pin 26). The CH7023/CH7024 49-pin TFBGA comes with two video outputs, primary CVBS or S-video Y (pin E5) and secondary CVBS or S-video C (pin F6).

The CH7023/CH7024 48-pin LQFP package comes with fixed single serial port address (76h – 7 bit address) while the CH7023/CH7024 49-pin TFBGA package provides two user selectable serial port addresses via AS pin pull up or pull down option.

1.1 Package Diagram

1.1.1 The 48-pin LQFP Package Diagram

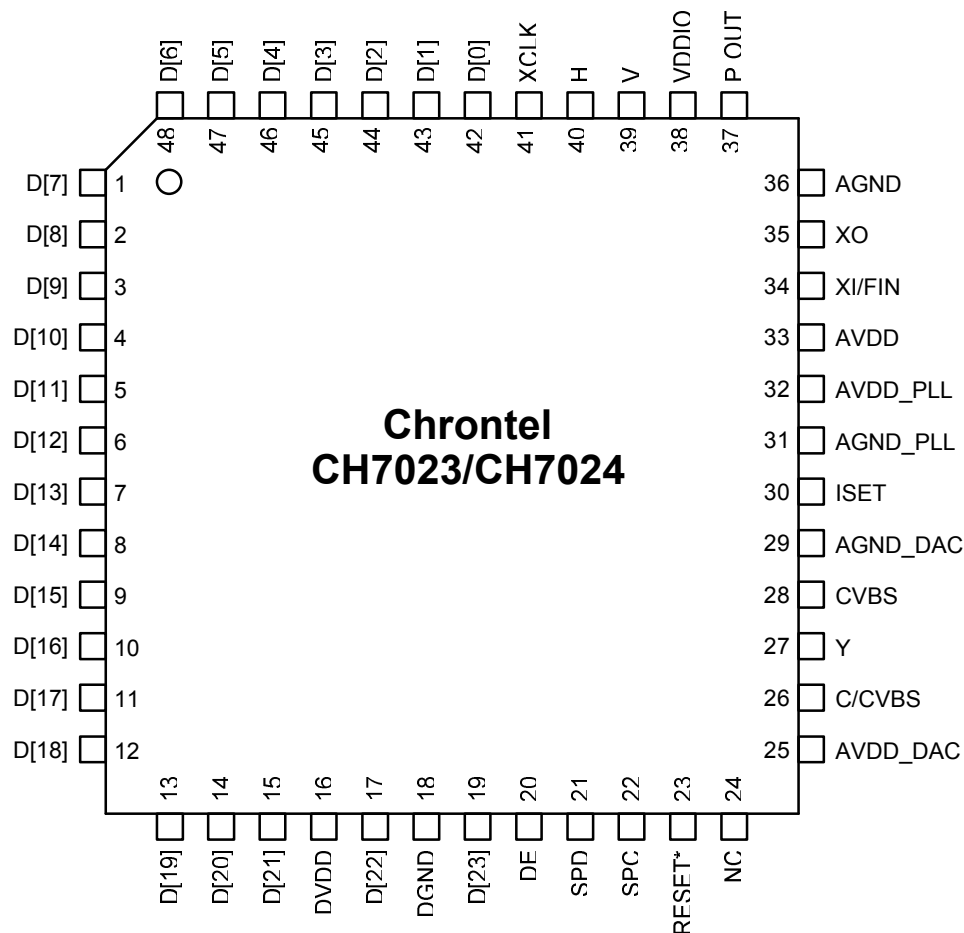

Figure 2: 48-LQFP Package (top view)

1.1.2 The 49-pin TFBGA Package Diagram

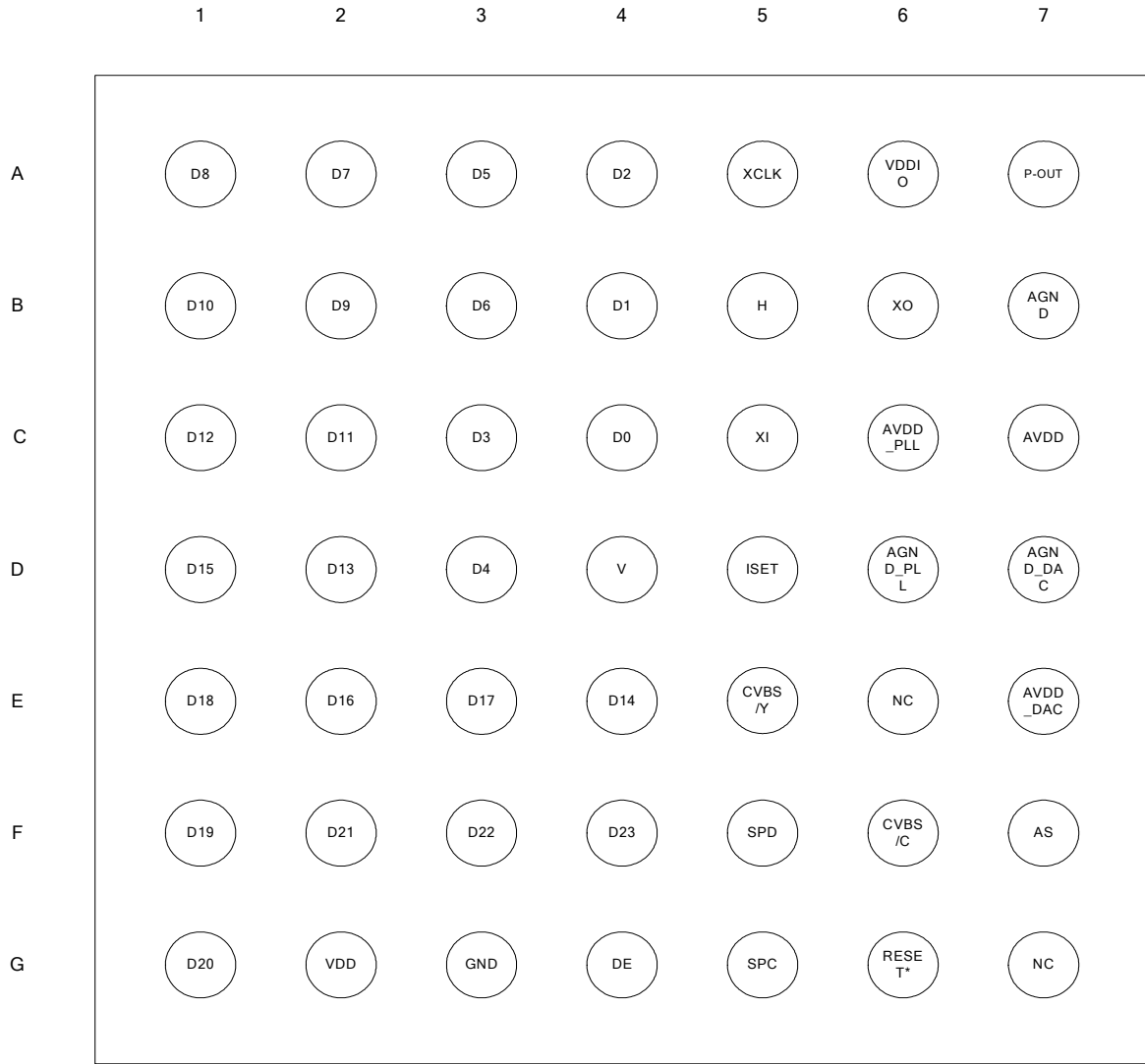

Figure 3: 49-Pin TFBGA Package (top view)

1.2 Pin Description

1.2.1 The 48-pin LQFP Pin Description

The 48-pin LQFP Package does not have AS pin to select second serial port address option. Refer to application note AN-98 for device address byte (DAB) details. The serial port device address for the read and write operation is fixed at ECh and EDh respectively.

It has internal switch to provide separate primary CVBS (pin 28) and S-video Y (pin27) outputs. Refer to section 2.3.2 Video DAC output and the Control Register 0Ah for the video DAC output control.

Table 1: Pin Description (48-pin LQFP)

Pin #	Type	Symbol	Description
42-48, 1-15, 17,19	In	D[0]-D[23]	Data[0] through Data[23] Inputs These pins accept 24 data input lines from a digital video port of a graphics controller. The swing is defined by VDDIO.
40	In/Out	H	Horizontal Sync Input / Output When the SYO control bit is low, this pin accepts a horizontal sync input for use with the input data. The amplitude will be 0 to VDDIO. When the SYO control bit is high, the device will output a horizontal sync pulse. The amplitude will be 0 to VDDIO.
39	In/Out	V	Vertical Sync Input / Output When the SYO control bit is low, this pin accepts a vertical sync input for use with the input data. The amplitude will be 0 to VDDIO. When the SYO control bit is high, the device will output a vertical sync pulse. The amplitude will be 0 to VDDIO.
20	In	DE	Data Enable When the pin is high, the input data is active. When the pin is low, the input data is blanking.
24	–	NC	–
23	In	RESET*	Reset * Input This pin is internally pulled high. When this pin is low, the device is held in the power-on reset condition. When this pin is high, reset is controlled through the serial port.
21	In/Out	SPD	Serial Port Data Input / Output This pin functions as the bi-directional data pin of the serial port and operates with input level from 0 to VDDIO. Outputs are driven from 0 to VDDIO.
22	In	SPC	Serial Port Clock Input This pin functions as the clock pin of the serial port and operates with input level from 0 to VDDIO.
28	Out	CVBS	Composite Video This is a primary composite vide output when S-video Y (pin 27) is not used. This output is turned off when S-video Y output is used.
27	Out	Y	Luma Output The output is S-video luminance when the primary CVBS output (pin 28) is not used.

Table 1: Pin Description (cont'd)

Pin #	Type	Symbol	Description
26	Out	C/CVBS	Chroma/CVBS Output The output is S-video chrominance when S-video is used. But, when dual CVBS outputs are needed, this out pin can be used for secondary CVBS output in addition to the primary CVBS output (pin 28).
30	In	ISET	Current Set Resistor This pin sets the DAC current. A 1.2k ohm, 1% tolerance resistor should be connected between this pin and AGND_DAC (pin 29) using short and wide traces.
37	Out	P-Out	Pixel Clock Output This pin provides a clock signal to the graphics controller, which can be used as a reference frequency. The output driver is driven from the VDDIO supply. This output has a programmable tri-state. The capacitive loading on this pin should be kept to a minimum.
34	In	XI/FIN	Crystal Input / External Reference Input For master mode and some situation of the slave mode, a parallel resonance crystal (± 20 ppm) should be attached between this pin and XO. However, an external 3.3V CMOS compatible clock can drive the XI/FIN input.
35	Out	XO	Crystal Output For master mode and some situation of the slave mode, a parallel resonance crystal (± 20 ppm) should be attached between this pin and XI/FIN. However, if an external CMOS clock is attached to XI/FIN, XO should be left open.
41	In	XCLK	External Clock Inputs The input is the clock signal input to the device for use with the H, V, DE and D[23:0] data.
38	Power	VDDIO	IO Supply Voltage (1.2-3.3V)
16	Power	DVDD	Digital Supply Voltage (1.8V)
18	Power	DGND	Digital Ground
25	Power	AVDD_DAC	DAC Supply Voltage (2.5-3.3V)
29	Power	AGND_DAC	DAC Ground
32	Power	AVDD_PLL	PLL Supply Voltage (1.8V)
31	Power	AGND_PLL	PLL Ground
33	Power	AVDD	Crystal Supply Voltage (2.5-3.3V)
36	Power	AGND	Crystal Ground

1.2.2 The 49-pin TFBGA Pin Description

The 49-pin TFBGA Package has AS pin to select second serial port address. Refer to application note AN-98 for device address byte (DAB). The device address for read operation can be either ECh or EAh based on external pull-down or pull-up with AS pin respectively. The device address for write operation can be either EDh or EBh.

It does not has internal switch to provide separate primary CVBS and S-video Y outputs. Instead, it has single or dual CVBSs or S-video C and Y output. Refer to section 2.3.2 Video DAC output and the Control Register 0Ah for the video DAC output control.

Table 2: Pin Description (49-pin TFBGA)

BGA Pin #	Type	Symbol	Description
A1-4,B1-B4,C1-C4,D1-D3,E1-E4,F1-F4,G1	In	D[0]-D[23]	Data[0] through Data[23] Inputs These pins accept 24 data input lines from a digital video port of a graphics controller. The swing is defined by VDDIO.
B5	In/Out	H	Horizontal Sync Input / Output When the SYO control bit is low, this pin accepts a horizontal sync input for use with the input data. The amplitude will be 0 to VDDIO. When the SYO control bit is high, the device will output a horizontal sync pulse. The output is driven from the VDDIO supply.
D4	In/Out	V	Vertical Sync Input / Output When the SYO control bit is low, this pin accepts a vertical sync input for use with the input data. The amplitude will be 0 to VDDIO. When the SYO control bit is high, the device will output a vertical sync pulse. The output is driven from the VDDIO supply.
G4	In	DE	Data Enable When the pin is high, the input data is active. When the pin is low, the input data is blanking.
F7	In	AS	Serial Port Address Select This pin is internally pulled low. When AS is high, the address is 75h – 7 bit address. Otherwise, the address is 76h – 7 bit address.
G7	–	NC	–
G6	In	RESET*	Reset * Input This pin is internally pulled high. When this pin is low, the device is held in the power-on reset condition. When this pin is high, reset is controlled through the serial port.
F5	In/Out	SPD	Serial Port Data Input / Output This pin functions as the bi-directional data pin of the serial port and operates with input level from 0 to VDDIO. Outputs are driven from 0 to VDDIO.
G5	In	SPC	Serial Port Clock Input This pin functions as the clock pin of the serial port and operates with input level from 0 to VDDIO.
E6	–	NC	–
E5	Out	CVBS/Y	Luma Output The output can be either a primary CVBS or S-video luminance.

Table 2: Pin Description (cont'd)

BGA Pin #	Type	Symbol	Description
F6	Out	CVBS/C	Chroma Output The output can be either secondary CVBS when dual CVBSs are needed or S-video chrominance when S-video is selected. In single CVBS output mode, this output is turned off to save power.
D5	Out	ISET	Current Set Resistor This pin sets the DAC current. A 1.2k ohm, 1% tolerance resistor should be connected between this pin and AGND_DAC (pin D7) using short and wide traces.
A7	Out	P-Out	Pixel Clock Output This pin provides a clock signal to the graphics controller, which can be used as a reference frequency. The output driver is driven from the VDDIO supply. This output has a programmable tri-state. The capacitive loading on this pin should be kept to a minimum.
C5	In	XI/FIN	Crystal Input / External Reference Input For master mode and some situation of the slave mode, a parallel resonance crystal (± 20 ppm) should be attached between this pin and XO. However, an external +3.3V CMOS compatible clock can drive the XI/FIN input.
B6	Out	XO	Crystal Output For master mode and some situation of the slave mode, a parallel resonance crystal (± 20 ppm) should be attached between this pin and XI/FIN. However, if an external CMOS clock is attached to XI/FIN, XO should be left open.
A5	In	XCLK	External Clock Inputs The input is the clock signal input to the device for use with the H, V, DE and D[23:0] data.
A6	Power	VDDIO	IO Supply Voltage (1.2-3.3V)
G2	Power	VDD	Digital Supply Voltage (1.8V)
G3	Power	GND	Digital Ground
E7	Power	AVDD_DAC	DAC Supply Voltage (2.5-3.3V)
D7	Power	AGND_DAC	DAC Ground
C6	Power	AVDD_PLL	PLL Supply Voltage (1.8V)
D6	Power	AGND_PLL	PLL Ground
C7	Power	AVDD	Crystal Supply Voltage (2.5-3.3V)
B7	Power	AGND	Crystal Ground

2.0 PACKAGE DIMENSIONS

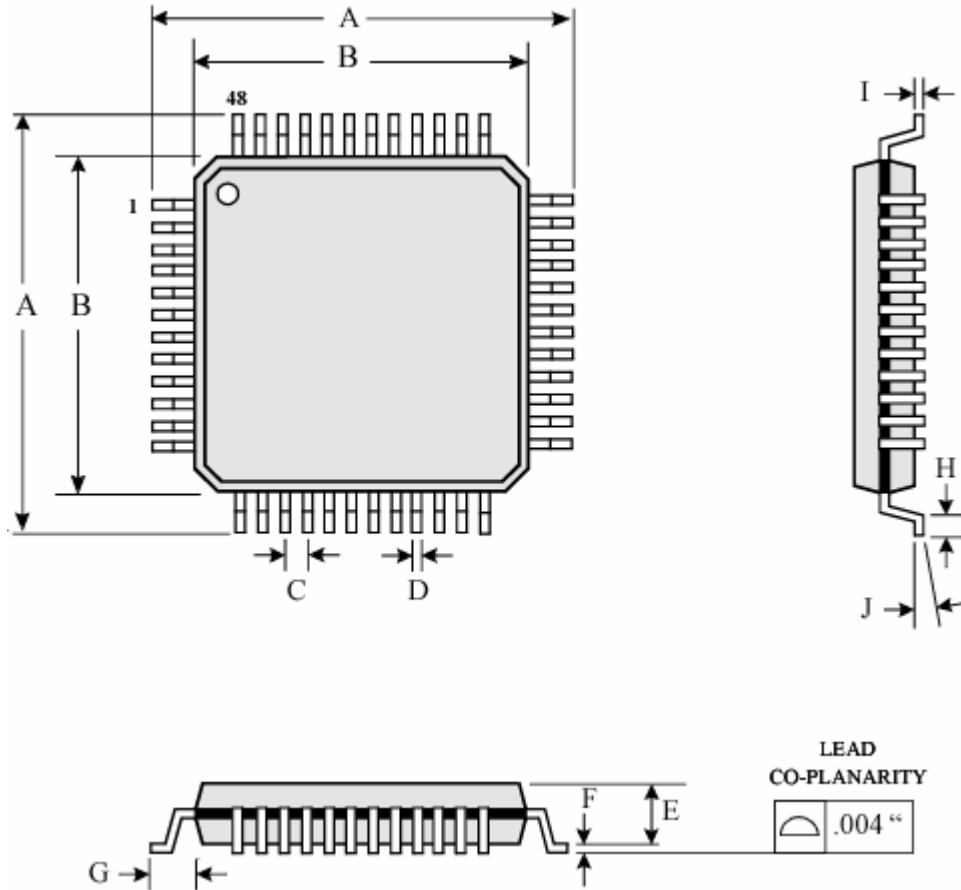

Figure 4: 48 Pin LQFP Package

Table of Dimensions

No. of Leads		SYMBOL									
48 (7 X 7 mm)		A	B	C	D	E	F	G	H	I	J
Milli- meters	MIN	9	7	0.5	0.17	1.35	0.05	1.00	0.45	0.09	0°
	MAX				0.27	1.45	0.15		0.75	0.20	7°

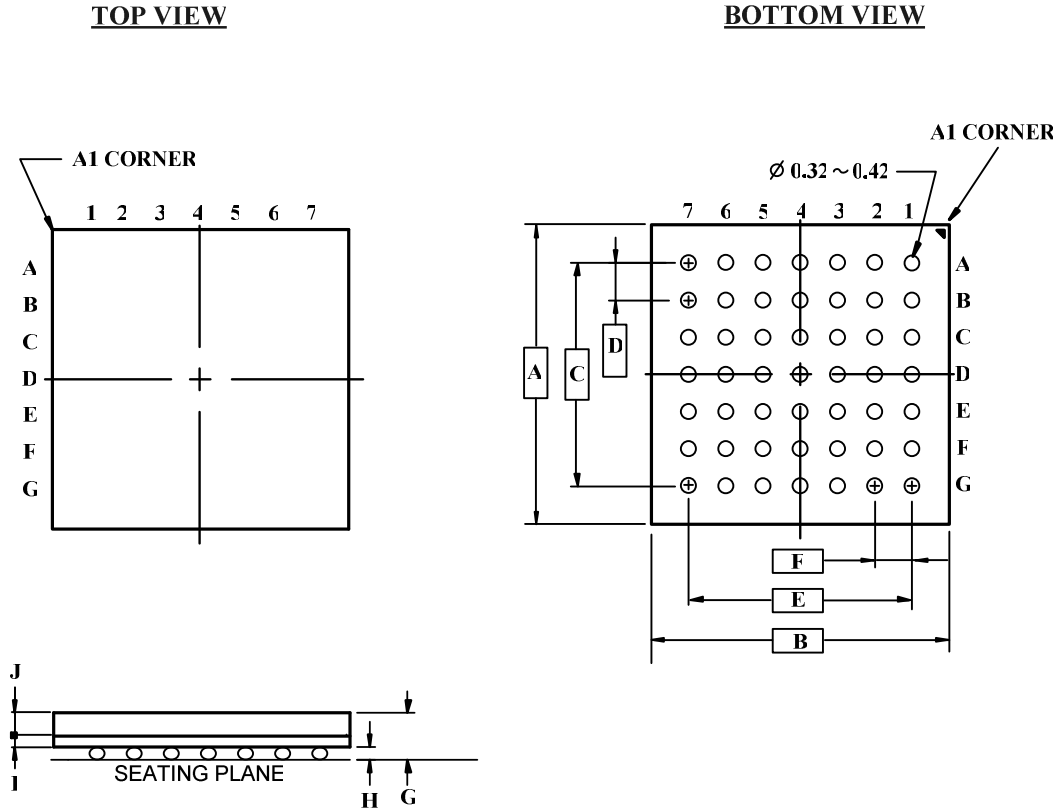

Figure 5: 49 Pin TFBGA Package

Table of Dimensions

No. of Leads		SYMBOL									
49 (6 X 6 mm)		A	B	C	D	E	F	G	H	I	J
Milli-meters	MIN	6.00	6.00	4.80	0.80	4.80	0.80		0.22	0.26	0.53
	MAX							1.20	0.32		

Notes:

- All dimensions conform to JEDEC standard MO-216.

Disclaimer

This document provides technical information for the user. Chrontel reserves the right to make changes at any time without notice to improve and supply the best possible product and is not responsible and does not assume any liability for misapplication or use outside the limits specified in this document. We provide no warranty for the use of our products and assume no liability for errors contained in this document. The customer should make sure that they have the most recent data sheet version. Customers should take appropriate action to ensure their use of the products does not infringe upon any patents. Chrontel, Inc. respects valid patent rights of third parties and does not infringe upon or assist others to infringe upon such rights.

Chrontel PRODUCTS ARE NOT AUTHORIZED FOR AND SHOULD NOT BE USED WITHIN LIFE SUPPORT SYSTEMS OR NUCLEAR FACILITY APPLICATIONS WITHOUT THE SPECIFIC WRITTEN CONSENT OF Chrontel. Life support systems are those intended to support or sustain life and whose failure to perform when used as directed can reasonably expect to result in personal injury or death.

ORDERING INFORMATION				
Part Number	Package Type	Copy Protection	Output Video Switch	Shipping Format
CH7023B-GF	49TFBGA, Lead-free	Macrovision™	No	Tray, 4290 per dry pack bag
CH7023B-GF-TR	49TFBGA, Lead-free, Tape & reel	Macrovision™	No	T&R, 2000 per dry pack bag
CH7023B-DF	48LQFP, Lead-free	Macrovision™	Yes	Tray, 2500 per dry pack bag
CH7023B-DF-TR	48LQFP, Lead-free, Tape & reel	Macrovision™	Yes	T&R, 1000 per dry pack bag
CH7024B-GF	49TFBGA, Lead-free	None	No	Tray, 4290 per dry pack bag
CH7024B-GF-TR	49TFBGA, Lead-free, Tape & reel	None	No	T&R, 2000 per dry pack bag
CH7024B-DF	48LQFP, Lead-free	None	Yes	Tray, 2500 per dry pack bag
CH7024B-DF-TR	48LQFP, Lead-free, Tape & reel	None	Yes	T&R, 1000 per dry pack bag

Chrontel

2210 O'Toole Avenue, Suite 100,
 San Jose, CA 95131-1326
 Tel: (408) 383-9328
 Fax: (408) 383-9338
 www.chrontel.com
 E-mail: sales@chrontel.com