

- **Low Supply-Voltage Range, 1.8 V . . . 3.6 V**
- **Ultralow-Power Consumption:**
  - Standby mode: 1.3  $\mu$ A
  - RAM Retention Off Mode: 0.1  $\mu$ A
- **Low Operating Current:**
  - 7  $\mu$ A at 32 kHz, 2.2 V
  - 250  $\mu$ A at 1 MHz, 2.2 V
- **Five Power-Saving Modes**
- **Wake-Up From Standby Mode in 6  $\mu$ s**
- **16-Bit RISC Architecture, 125-ns Instruction Cycle Time**
- **12-Bit A/D Converter With Internal Reference, Sample-And-Hold and Autoscan Feature**
- **16-Bit Timer With Seven Capture/Compare-With-Shadow Registers, Timer\_B**
- **16-Bit Timer With Three Capture/Compare Registers, Timer\_A**
- **On-Chip Comparator**
- **Serial Onboard Programming, No External Programming Voltage Needed**
- **Programmable Code Protection by Security Fuse**
- **Family Members Include:**
  - MSP430F133†: 8KB Flash Memory, 256B RAM
  - MSP430F135†: 16KB Flash Memory, 512B RAM
  - MSP430F147†: 32KB Flash Memory, 1KB RAM
  - MSP430F148†: 48KB Flash Memory, 2KB RAM
  - MSP430F149†: 60KB Flash Memory, 2KB RAM
- **Available in 64-Pin Quad Flat Pack (QFP)**

†Advanced Information

## description

The Texas Instruments MSP430 series is an ultralow-power microcontroller family consisting of several devices featuring different sets of modules targeted to various applications. The microcontroller is designed to be battery operated for use in extended-time applications. The MSP430 achieves maximum code efficiency with its 16-bit RISC architecture, 16-bit CPU-integrated registers, and a constant generator. The digitally-controlled oscillator provides wake-up from low-power mode to active mode in less than 6  $\mu$ s. The MSP430x13x and the MSP430x14x series are microcontroller configurations with two built-in 16-bit timers, a fast 12-bit A/D converter, one or two universal serial synchronous/asynchronous communication interfaces (USART), and 48 I/O pins.

Typical applications include sensor systems that capture analog signals, convert them to digital values, and process and transmit the data to a host system. The timers make the configurations ideal for industrial control applications such as ripple counters, digital motor control, EE-meters, hand-held meters, etc. The hardware multiplier enhances the performance and offers a broad code and hardware-compatible family solution.

Please be aware that an important notice concerning availability, standard warranty, and use in critical applications of Texas Instruments semiconductor products and disclaimers thereto appears at the end of this data sheet.

# MSP430x13x, MSP430x14x MIXED SIGNAL MICROCONTROLLER

SLAS272A – JULY 2000 – REVISED JULY 2000

## AVAILABLE OPTIONS

T <sub>A</sub>	PACKAGED DEVICES
	PLASTIC 64-PIN QFP (PM)
-40°C to 85°C	MSP430F133IPM MSP430F135IPM MSP430F147IPM MSP430F148IPM MSP430F149IPM

pin designation, MSP430F133, MSP430F135

## PM PACKAGE (TOP VIEW)

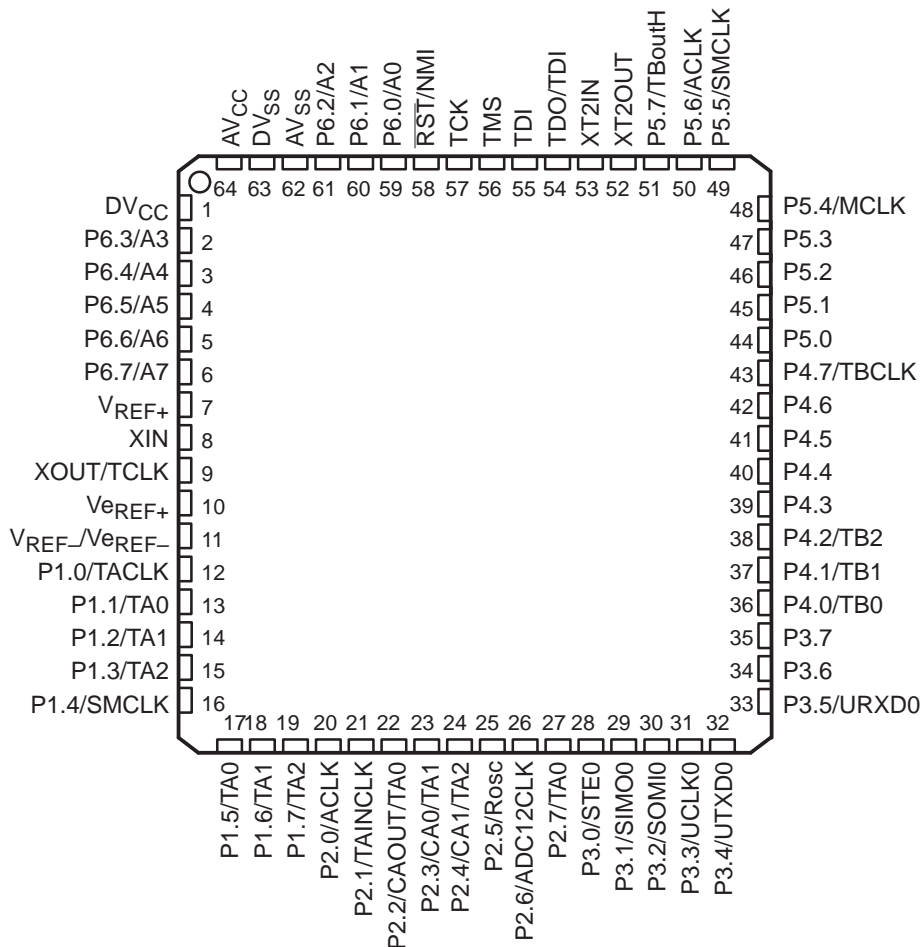

PRODUCT PREVIEW

# MSP430x13x, MSP430x14x MIXED SIGNAL MICROCONTROLLER

SLAS272A – JULY 2000 – REVISED JULY 2000

## pin designation, MSP430F147, MSP430F148, MSP430F149

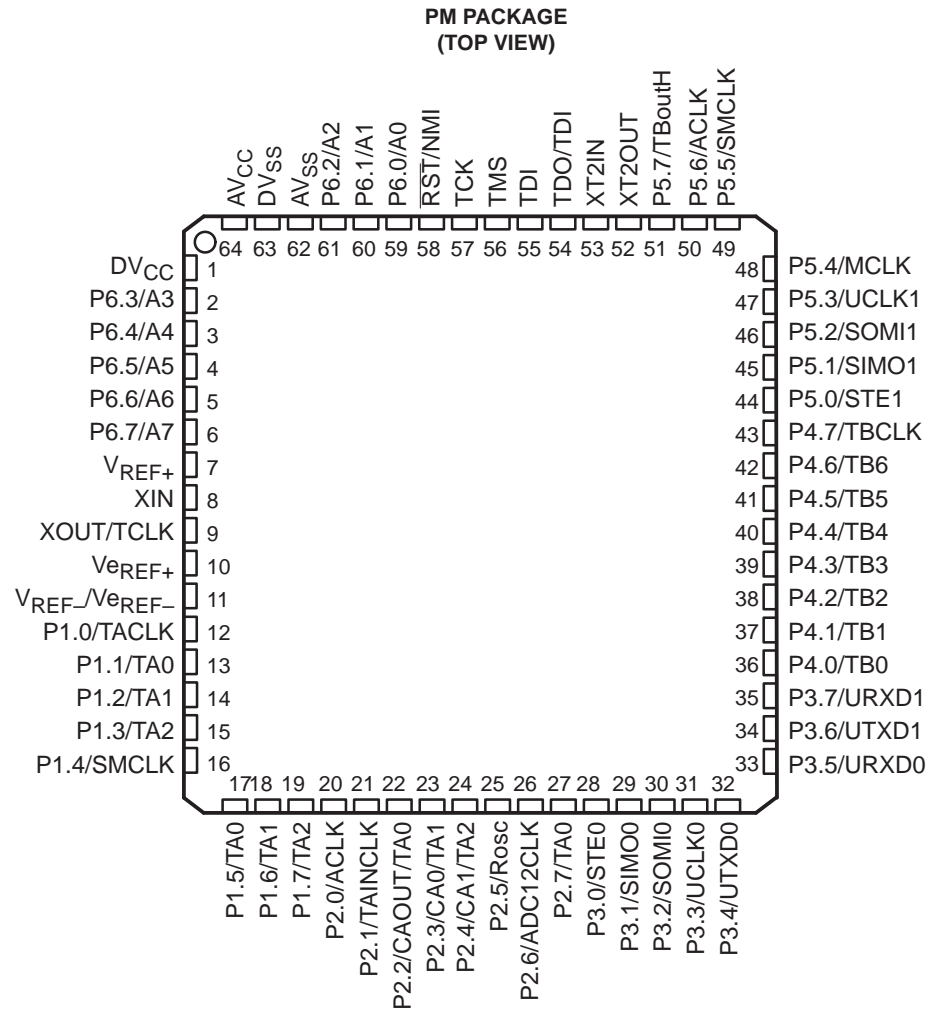

**PRODUCT PREVIEW**

# MSP430x13x, MSP430x14x MIXED SIGNAL MICROCONTROLLER

SLAS272A – JULY 2000 – REVISED JULY 2000

## functional block diagrams

### MSP430x14x

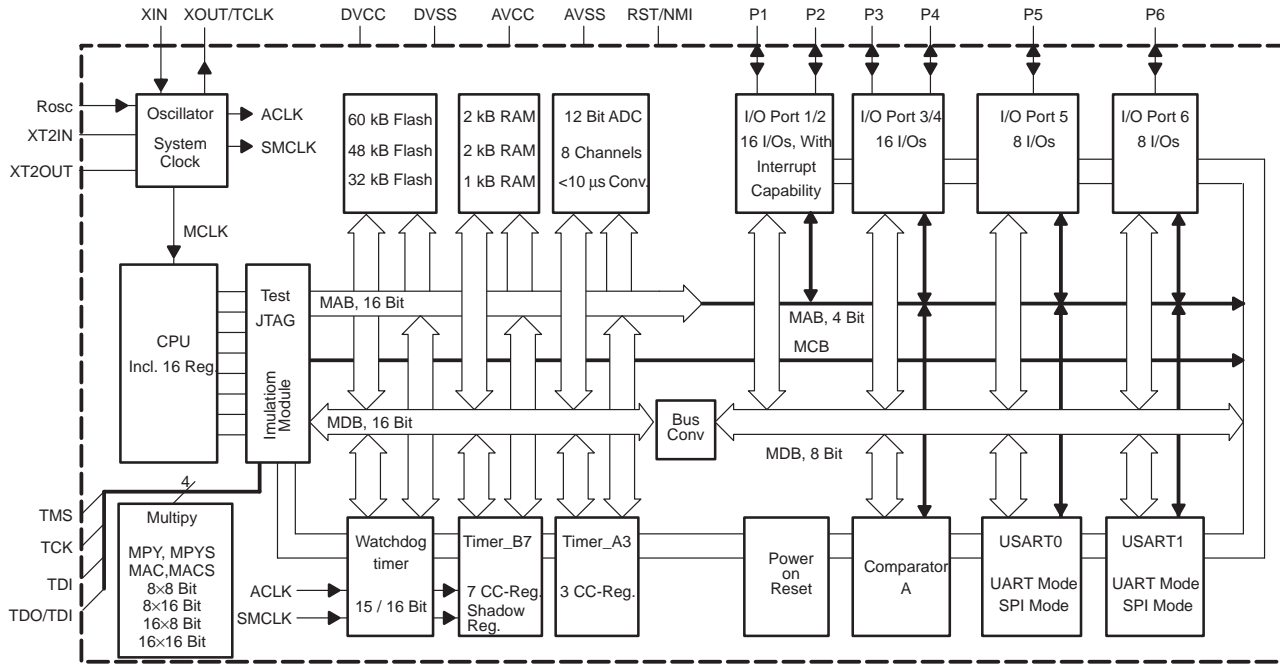

### MSP430x13x

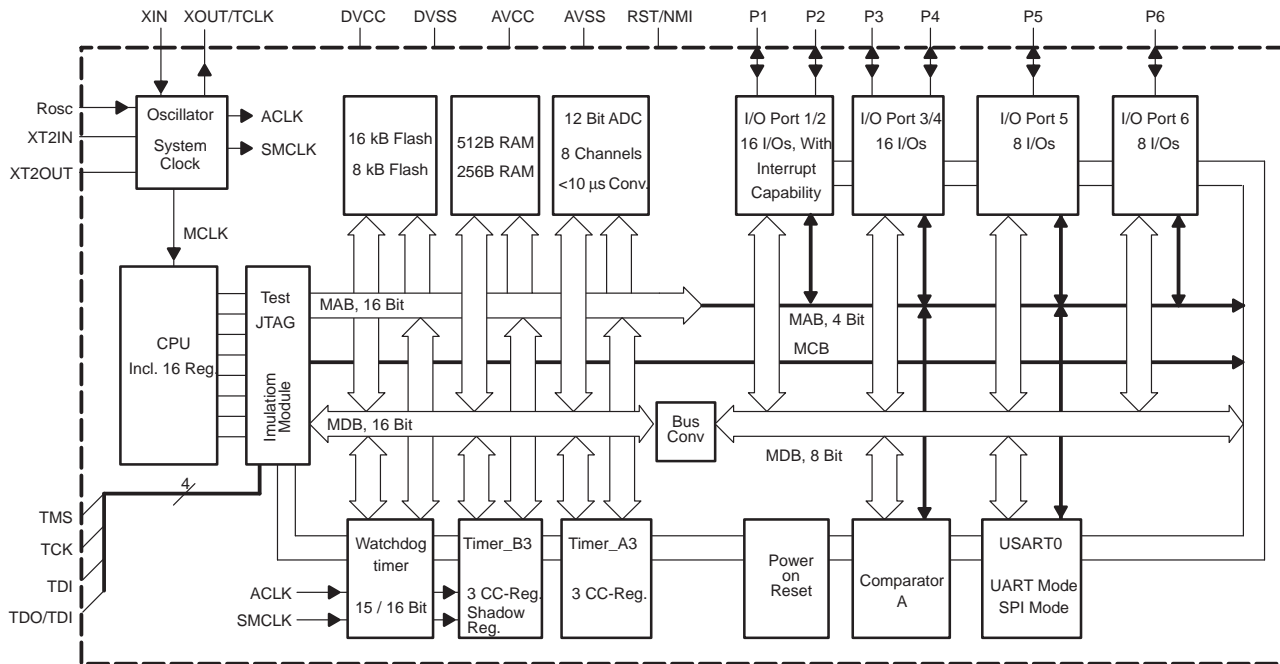

PRODUCT PREVIEW

# MSP430x13x, MSP430x14x MIXED SIGNAL MICROCONTROLLER

SLAS272A – JULY 2000 – REVISED JULY 2000

## Terminal Functions

TERMINAL NAME	NO.	I/O	DESCRIPTION
AV <sub>CC</sub>	64		Analog supply voltage, positive terminal. Supplies only the analog portion of the analog-to-digital converter.
AV <sub>SS</sub>	62		Analog supply voltage, negative terminal. Supplies only the analog portion of the analog-to-digital converter.
DV <sub>CC</sub>	1		Digital supply voltage, positive terminal. Supplies all digital parts.
DV <sub>SS</sub>	63		Digital supply voltage, negative terminal. Supplies all digital parts.
P1.0/TACLK	12	I/O	General digital I/O pin/Timer_A, clock signal TACLK input
P1.1/TA0	13	I/O	General digital I/O pin/Timer_A, capture: CCI0A input, compare: Out0 output
P1.2/TA1	14	I/O	General digital I/O pin/Timer_A, capture: CCI1A input, compare: Out1 output
P1.3/TA2	15	I/O	General digital I/O pin/Timer_A, capture: CCI2A input, compare: Out2 output
P1.4/SMCLK	16	I/O	General digital I/O pin/SMCLK signal output
P1.5/TA0	17	I/O	General digital I/O pin/Timer_A, compare: Out0 output
P1.6/TA1	18	I/O	General digital I/O pin/Timer_A, compare: Out1 output
P1.7/TA2	19	I/O	General digital I/O pin/Timer_A, compare: Out2 output/
P2.0/ACLK	20	I/O	General digital I/O pin/ACLK output
P2.1/TAINCLK	21	I/O	General digital I/O pin/Timer_A, clock signal at INCLK
P2.2/CAOUT/TA0	22	I/O	General digital I/O pin/Timer_A, capture: CCI0B input/Comparator_A output
P2.3/CA0/TA1	23	I/O	General digital I/O pin/Timer_A, compare: Out1 output/Comparator_A input
P2.4/CA1/TA2	24	I/O	General digital I/O pin/Timer_A, compare: Out2 output/Comparator_A input
P2.5/Rosc	25	I/O	General-purpose digital I/O pin, input for external resistor defining the DCO nominal frequency
P2.6/ADC12CLK	26	I/O	General digital I/O pin, conversion clock – 12-bit ADC
P2.7/TA0	27	I/O	General digital I/O pin/Timer_A, compare: Out0 output
P3.0/STE0	28	I/O	General digital I/O, slave transmit enable – USART0/SPI mode
P3.1/SIMO0	29	I/O	General digital I/O, slave in/master out of USART0/SPI mode
P3.2/SOMI0	30	I/O	General digital I/O, slave out/master in of USART0/SPI mode
P3.3/UCLK0	31	I/O	General digital I/O, external clock input – USART0/UART or SPI mode, clock output – USART0/SPI mode
P3.4/UTXD0	32	I/O	General digital I/O, transmit data out – USART0/UART mode
P3.5/URXD0	33	I/O	General digital I/O, receive data in – USART0/UART mode
P3.6/UTXD1†	34	I/O	General digital I/O, transmit data out – USART1/UART mode
P3.7/URXD1†	35	I/O	General digital I/O, receive data in – USART1/UART mode
P4.0/TB0	36	I/O	General-purpose digital I/O, capture I/P or PWM output port – Timer_B7 CCR0
P4.1/TB1	37	I/O	General-purpose digital I/O, capture I/P or PWM output port – Timer_B7 CCR1
P4.2/TB2	38	I/O	General-purpose digital I/O, capture I/P or PWM output port – Timer_B7 CCR2
P4.3/TB3†	39	I/O	General-purpose digital I/O, capture I/P or PWM output port – Timer_B7 CCR3
P4.4/TB4†	40	I/O	General-purpose digital I/O, capture I/P or PWM output port – Timer_B7 CCR4
P4.5/TB5†	41	I/O	General-purpose digital I/O, capture I/P or PWM output port – Timer_B7 CCR5
P4.6/TB6†	42	I/O	General-purpose digital I/O, capture I/P or PWM output port – Timer_B7 CCR6
P4.7/TBCLK	43	I/O	General-purpose digital I/O, input clock TBCLK – Timer_B7
P5.0/STE1†	44	I/O	General-purpose digital I/O, slave transmit enable – USART1/SPI mode
P5.1/SIMO1†	45	I/O	General-purpose digital I/O slave in/master out of USART1/SPI mode
P5.2/SOMI1†	46	I/O	General-purpose digital I/O, slave out/master in of USART1/SPI mode
P5.3/UCLK1†	47	I/O	General-purpose digital I/O, external clock input – USART1/UART or SPI mode, clock output – USART1/SPI mode
P5.4/MCLK	48	I/O	General-purpose digital I/O, main system clock MCLK output
P5.5/SMCLK	49	I/O	General-purpose digital I/O, submain system clock SMCLK output

† 14x devices only

PRODUCT PREVIEW

# MSP430x13x, MSP430x14x MIXED SIGNAL MICROCONTROLLER

SLAS272A – JULY 2000 – REVISED JULY 2000

## Terminal Functions (Continued)

TERMINAL NAME	NO.	I/O	DESCRIPTION
P5.6/ACLK	50	I/O	General-purpose digital I/O, auxiliary clock ACLK output
P5.7/Tbouth	51	I/O	General-purpose digital I/O, switch all PWM digital output ports to high impedance – Timer_B7 TB0 to TB6
P6.0/A0	59	I/O	General digital I/O, analog input a0 – 12-bit ADC
P6.1/A1	60	I/O	General digital I/O, analog input a1 – 12-bit ADC
P6.2/A2	61	I/O	General digital I/O, analog input a2 – 12-bit ADC
P6.3/A3	2	I/O	General digital I/O, analog input a3 – 12-bit ADC
P6.4/A4	3	I/O	General digital I/O, analog input a4 – 12-bit ADC
P6.5/A5	4	I/O	General digital I/O, analog input a5 – 12-bit ADC
P6.6/A6	5	I/O	General digital I/O, analog input a6 – 12-bit ADC
P6.7/A7	6	I/O	General digital I/O, analog input a7 – 12-bit ADC
RST/NMI	58	I	Reset input, nonmaskable interrupt input port, or bootstrap loader start (in Flash devices).
TCK	57	I	Test clock. TCK is the clock input port for device programming test and bootstrap loader start (in Flash devices).
TDI	55	I	Test data input. TDI is used as a data input port. The device protection fuse is connected to TDI.
TDO/TDI	54	I/O	Test data output port. TDO/TDI data output or programming data input terminal
TMS	56	I	Test mode select. TMS is used as an input port for device programming and test.
VeREF+	10	I/P	Input for an external reference voltage to the ADC
VREF+	7	O	Output of positive terminal of the reference voltage in the ADC
VREF-/VeREF-	11	O	Negative Terminal for the ADC's reference voltage for both sources, the internal reference voltage, or an external applied reference voltage
XIN	8	I	Input port for crystal oscillator XT1. Standard or watch crystals can be connected.
XOUT/TCLK	9	I/O	Output terminal of crystal oscillator XT1 or test clock input
XT2IN	53	I	Input port for crystal oscillator XT2. Only standard crystals can be connected.
XT2OUT	52	O	Output terminal of crystal oscillator XT2

### short-form description

#### processing unit

The processing unit is based on a consistent and orthogonal CPU and instruction set. This design structure results in a RISC-like architecture, highly transparent to the application development and notable for its ease of programming. All operations other than program-flow instructions are consequently performed as register operations in conjunction with seven addressing modes for source and four modes for destination operand.

#### CPU

The CPU has sixteen registers that provide reduced instruction execution time. This reduces the register-to-register operation execution time to one cycle of the processor frequency.

Four of the registers are reserved for special use as program counter, stack pointer, status register, and constant generator. The remaining registers are available as general-purpose registers.

Peripherals are connected to the CPU using a data address and control bus, and can be easily handled with all memory manipulation instructions.

Program Counter	PC/R0
Stack Pointer	SP/R1
Status Register	SR/CG1/R2
Constant Generator	CG2/R3
General-Purpose Register	R4
General-Purpose Register	R5
⋮	
General-Purpose Register	R14
General-Purpose Register	R15

PRODUCT PREVIEW

**short-form description (continued)**

**instruction set**

The instruction set for this register-to-register architecture constitutes a powerful and easy-to-use assembler language. The instruction set consists of 51 instructions with three formats and seven address modes. Table 1 provides a summary and example of the three types of instruction formats; the address modes are listed in Table 2.

**Table 1. Instruction Word Formats**

Dual operands, source-destination	e.g. ADD R4,R5	R4 + R5 → R5
Single operands, destination only	e.g. CALL R8	PC →(TOS), R8 → PC
Relative jump, un/conditional	e.g. JNE	Jump-on-equal bit = 0

Each instruction operating on word and byte data is identified by the suffix B.

<b>Examples:</b>	<b>WORD INSTRUCTIONS</b>	<b>BYTE INSTRUCTIONS</b>
	MOV EDE, TONI	MOV.B EDE,TONI
	ADD #235h,&MEM	ADD.B #35h,&MEM
	PUSH R5	PUSH.B R5
	SWPB R5	—

**Table 2. Address Mode Descriptions**

ADDRESS MODE	S	D	SYNTAX	EXAMPLE	OPERATION
Register	✓	✓	MOV Rs,Rd	MOV R10,R11	R10 → R11
Indexed	✓	✓	MOV X(Rn),Y(Rm)	MOV 2(R5),6(R6)	M(2+R5) → M(6+R6)
Symbolic (PC relative)	✓	✓	MOV EDE,TONI		M(EDE) → M(TONI)
Absolute	✓	✓	MOV &MEM,&TCDAT		M(MEM) → M(TCDAT)
Indirect	✓		MOV at Rn,Y(Rm)	MOV at R10,Tab(R6)	M(R10) → M(Tab+R6)
Indirect autoincrement	✓		MOV at Rn+,Rm	MOV at R10+,R11	M(R10) → R11 R10 + 2 → R10
Immediate	✓		MOV #X,TONI	MOV #45,TONI	#45 → M(TONI)

NOTE: S = source D = destination

Computed branches (BR) and subroutine call (CALL) instructions use the same address modes as other instructions. These address modes provide *indirect* addressing, which is ideally suited for computed branches and calls. The full use of this programming capability results in a program structure which is different from structures used with conventional 8- and 16-bit controllers. For example, numerous routines can be easily designed to deal with pointers and stacks instead of using flag-type programs for flow control.

**operating modes and interrupts**

The MSP430 operating modes provide advanced support of the requirements for ultralow-power and ultralow-energy consumption. This goal is achieved by intelligent management during the different operating modes of modules and CPU states and is fully supported during interrupt event handling. An interrupt event awakes the system from each of the various operating modes and returns, using the *RETI* instruction, to the mode that was selected before the interrupt event occurred. The different requirements on CPU and modules—driven by system cost and current consumption objectives—require the use of different clock signals:

- Auxiliary clock ACLK, sourced by LFXT1CLK (crystal frequency) and used by the peripheral modules
- Main system clock MCLK, used by the CPU and system
- Subsystem clock SMCLK, used by the peripheral modules

# MSP430x13x, MSP430x14x MIXED SIGNAL MICROCONTROLLER

SLAS272A – JULY 2000 – REVISED JULY 2000

## operating modes and interrupts (continued)

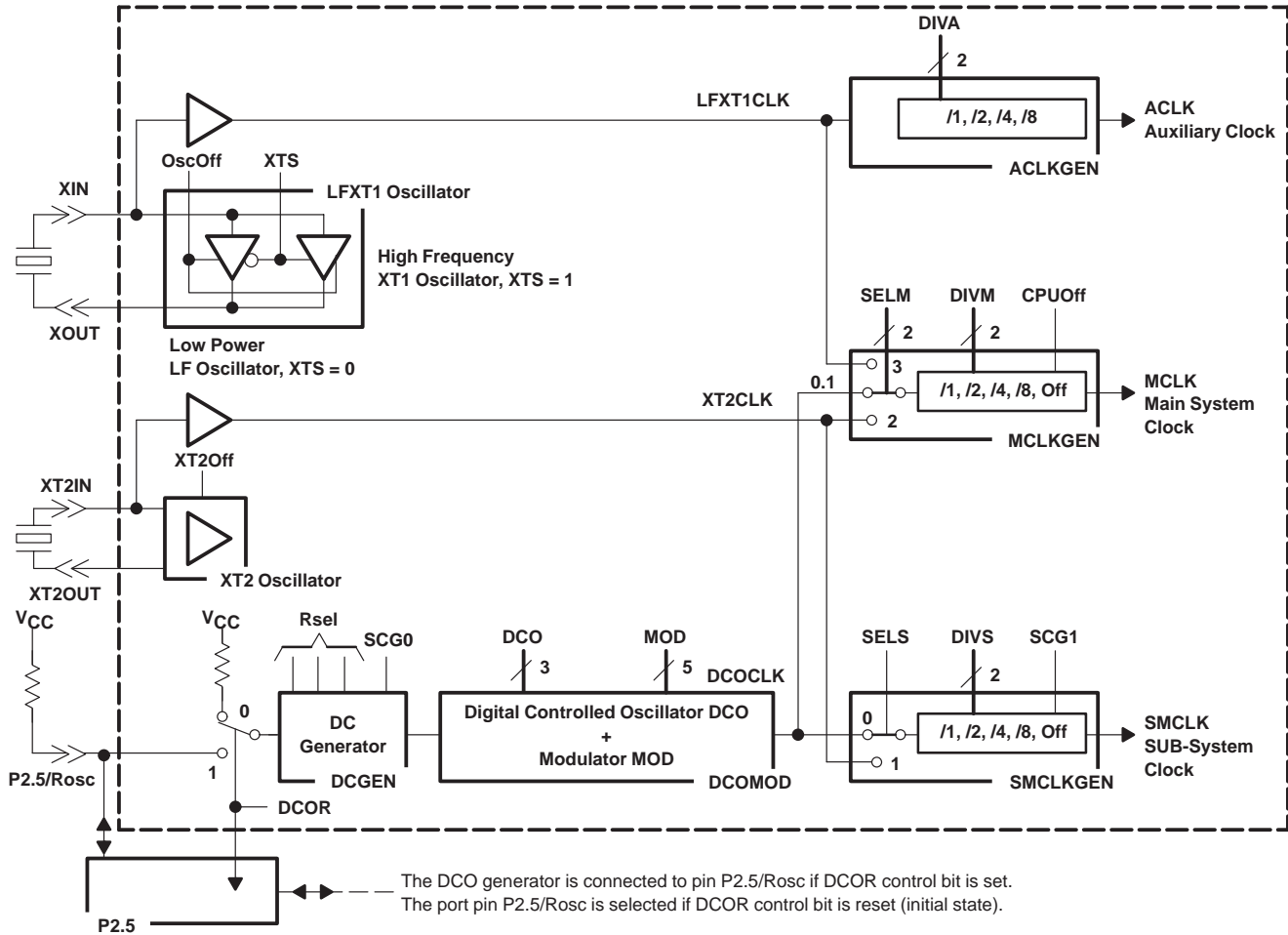

Any of these clock sources—LFXT1CLK, XT2CLK, or DCOCLK—can be used to drive the MSP430 system.

LFXT1CLK is defined by connecting a low-power, low-frequency crystal to the oscillator, by connecting a high-frequency crystal to the oscillator, or by applying an external clock source. The high-frequency crystal oscillator is used if control bit XTS is set. The crystal oscillator may be switched off if LFXT1CLK is not required for the current operating mode.

XT2CLK is defined by connecting a high-frequency crystal to the oscillator or by applying an external clock source. Crystal oscillator XT2 may be switched off using the XT2Off control bit if not required by the current operating mode.

When DCOCLK is active, its frequency is selected or adjusted by software. DCOCLK is inactive or stopped when it is not being used by the CPU or peripheral modules. The dc generator can be stopped when SCG0 is reset and DCOCLK is not required. The dc generator determines the basic DCO frequency, and can be set by one external resistor or adjusted in eight steps by selection of integrated resistors.

### NOTE:

The system clock generator always starts with DCOCLK selected as MCLK (CPU clock) to ensure proper start of program execution. The software determines the final system clock through control bit manipulation.

The system clock MCLK is also selected by hardware to be the DCOCLK (DCO and DCGEN are on) if the crystal oscillator (XT1 or XT2) fails while being selected as MCLK. Without this *forced clock mode* the NMI, requested by the oscillator fault flag, can not be handled and control may be lost. Without forced-clock mode the processor could not execute any code until the failed oscillator restarts.

### low-power consumption capabilities

The various operating modes are handled by software by controlling the operation of the internal clock system. This clock system provides a large combination of hardware and software capabilities to run the application while maintaining the lowest power consumption and optimizing system costs. This is accomplished by:

- Use of the internal clock (DCO) generator without any external components
- Selection of an external crystal or ceramic resonator for lowest frequency and cost
- Selection and activation of the proper clock signals (LFXT1CLK, XT2Off, and/or DCOCLK) and clock predivider function. Control bit XT2Off is embedded in control register BCCTL1.
- Application of an external clock source

The control bits that most influence the operation of the clock system and support fast turnon from low power operating modes are located in the status register SR. Four bits control the CPU and the system clock generator: SCG1, SCG0, OscOff, and CPUOff.



CPUOff, SCG1, SCG0, and OscOff are the most important bits in low-power control when the basic function of the system clock generator is established. They are pushed to the stack whenever an interrupt is accepted and saved for returning to the operation before an interrupt request. They can be manipulated via indirect access to the data on the stack during execution of an interrupt handler so that program execution can be resume in another power operating mode after return-from-interrupt.

- CPUOff: Clock signal MCLK, used with the CPU, is active when the CPUOff bit is reset or stopped when set.
- SCG1: Clock signal SMCLK, used with peripherals, is enabled when the SCG1 bit is reset or stopped when set.
- OscOff: Crystal oscillator LFXT1 is active when the OscOff bit is reset. The LFXT1 oscillator can be inactive only when the OscOff bit is set and not used for MCLK. The setup time to start a crystal oscillation requires special consideration when the off option is used. Mask-programmable devices can disable this feature and the oscillator can never be switched off by software.
- SCG0: The dc generator is active when the SCG0 bit is reset. The DCO can be inactive only if the SCG0 bit is set and the DCOCLK signal is not used as MCLK or SMCLK. The dc current consumed by the dc generator defines the basic frequency of the DCOCLK.  
When the current is switched off (SCG0=1) the start of the DCOCLK is slightly delayed. This delay is in the microsecond range.
- DCOCLK: Clock signal DCOCLK is stopped if not used as MCLK or SMCLK. There are two situations when the SCG0 bit can not switch the DCOCLK signal off:  
The DCOCLK frequency is used as MCLK (CPUOff=0 and SELM.1=0), or the DCOCLK frequency is used as SMCLK (SCG1=0 and SELS=0).  
If DCOCLK is required for operation, the SCG0 bit can not switch the dc generator off.

# MSP430x13x, MSP430x14x MIXED SIGNAL MICROCONTROLLER

SLAS272A – JULY 2000 – REVISED JULY 2000

## interrupt vector addresses

The interrupt vectors and the power-up starting address are located in the address range 0FFFFh – 0FFE0h. The vector contains the 16-bit address of the appropriate interrupt-handler instruction sequence.

INTERRUPT SOURCE	INTERRUPT FLAG	SYSTEM INTERRUPT	WORD ADDRESS	PRIORITY
Power-up External Reset Watchdog Flash memory	WDTIFG KEYV (see Note 1)	Reset	0FFFEh	15, highest
NMI Oscillator Fault Flash memory access violation	NMIIFG (see Notes 1 & 4) OFIFG (see Notes 1 & 4) ACCVIFG (see Notes 1 & 4)	(Non)maskable (Non)maskable (Non)maskable	0FFFCh	14
Timer_B7 (see Note 5)	BCCIFG0 (see Note 2)	Maskable	0FFFAh	13
Timer_B7 (see Note 5)	BCCIFG1 to BCCIFG6 TBIFG (see Notes 1 & 2)	Maskable	0FFF8h	12
Comparator_A	CMPAIFG	Maskable	0FFF6h	11
Watchdog timer	WDTIFG	Maskable	0FFF4h	10
USART0 receive	URXIFG.0	Maskable	0FFF2h	9
USART0 transmit	UTXIFG.0	Maskable	0FFF0h	8
ADC	ADCIFG (see Notes 1 & 2)	Maskable	0FFEEh	7
Timer_A3	CCIFG0 (see Note 2)	Maskable	0FFECCh	6
Timer_A3	CCIFG1, CCIFG2, TAIFG (see Notes 1 & 2)	Maskable	0FFEAh	5
I/O port P1 (eight flags)	P1IFG.0 (see Notes 1 & 2) To P1IFG.7 (see Notes 1 & 2)	Maskable	0FFE8h	4
USART1 receive	URXIFG.1	Maskable	0FFE6h	3
USART1 transmit	UTXIFG.1		0FFE4h	2
I/O port P2 (eight flags)	P2IFG.0 (see Notes 1 & 2) To P2IFG.7 (see Notes 1 & 2)	Maskable	0FFE2h	1
			0FFE0h	0, lowest

- NOTES: 1. Multiple source flags  
 2. Interrupt flags are located in the module.  
 3. Nonmaskable: neither the individual nor the general interrupt-enable bit will disable an interrupt event.  
 4. (Non)maskable: the individual interrupt-enable bit can disable an interrupt event, but the general-interrupt enable can not disable it.  
 5. Timer\_B7 in MSP430x14x family has 7 CCRs; Timer\_B3 in MSP430x13x family has 3 CCRs; in Timer\_B3 there are only interrupt flags CCIFG0, 1, and 2, and the interrupt-enable bits CCIE0, 1, and 2 integrated.

## special function registers

Most interrupt and module-enable bits are collected in the lowest address space. Special-function register bits not allocated to a functional purpose are not physically present in the device. This arrangement provides simple software access.

PRODUCT PREVIEW

### interrupt enable 1 and 2

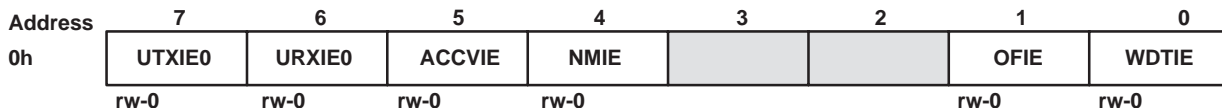

WDTIE: Watchdog-timer-interrupt enable signal

OFIE: Oscillator-fault-interrupt enable signal

NMIE: Nonmaskable-interrupt enable signal

ACCVIE: (Non)maskable-interrupt enable signal, access violation if FLASH memory/module is busy

URXIE0: USART0, UART, and SPI receive-interrupt enable signal

UTXIE0: USART0, UART, and SPI transmit-interrupt enable signal

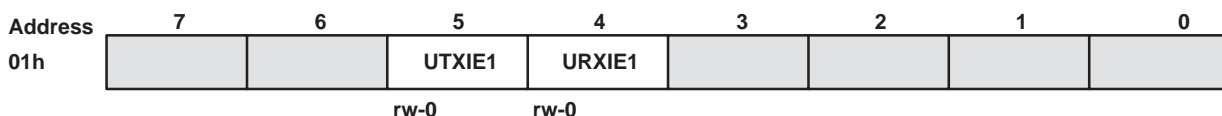

URXIE1: USART1, UART, and SPI receive-interrupt enable signal

UTXIE1: USART1, UART, and SPI transmit-interrupt enable signal

### interrupt flag register 1 and 2

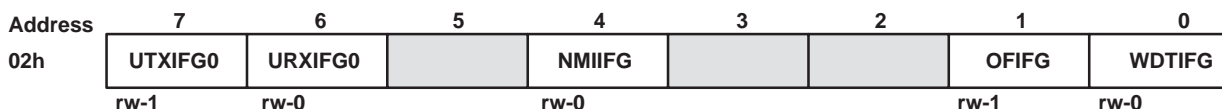

WDTIFG: Set on overflow or security key violation or reset on VCC power-on or reset condition at  $\overline{RST}/NMI$

OFIFG: Flag set on oscillator fault

NMIIFG: Set via  $\overline{RST}/NMI$  pin

URXIFG0: USART0, UART, and SPI receive flag

UTXIFG0: USART0, UART, and SPI transmit flag

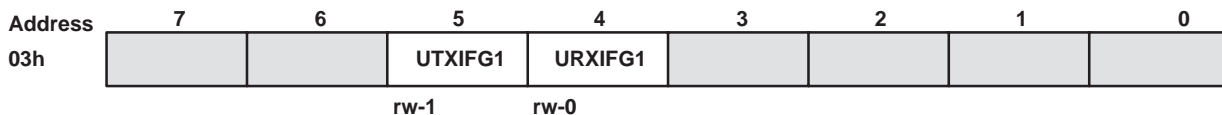

URXIFG1: USART1, UART, and SPI receive flag

UTXIFG1: USART1, UART, and SPI transmit flag

# MSP430x13x, MSP430x14x MIXED SIGNAL MICROCONTROLLER

SLAS272A – JULY 2000 – REVISED JULY 2000

## module enable registers 1 and 2



- URXE0:      USART0, UART receive enable
- UTXE0:      USART0, UART transmit enable
- USPIIE0:    USART0, SPI (synchronous peripheral interface) transmit and receive enable

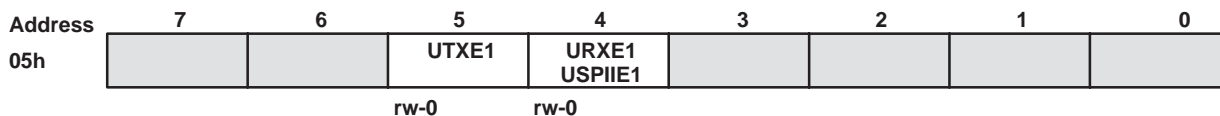

- URXE1:      USART1, UART receive enable
- UTXE1:      USART1, UART transmit enable
- USPIIE1:    USART1, SPI (synchronous peripheral interface) transmit and receive enable

Legend: rw:                      Bit Can Be Read and Written  
 rw-0:                              Bit Can Be Read and Written. It is Reset by PUC.  
 SFR Bit Not Present in Device

## memory organization

		MSP430F133	MSP430F135	MSP430F147	MSP430F148	MSP430F149
Memory	Size	8kB	16kB	32kB	48kB	60kB
Main: interrupt vector	Flash	0FFFFh – 0FFE0h	0FFFFh – 0FFE0h	0FFFFh – 0FFE0h	0FFFFh – 0FFE0h	0FFFFh – 0FFE0h
Main: code memory	Flash	0FFFFh – 0E000h	0FFFFh – 0C000h	0FFFFh – 08000h	0FFFFh – 04000h	0FFFFh – 01100h
Information memory	Size	256 Byte	256 Byte	256 Byte	256 Byte	256 Byte
	Flash	010FFh – 01000h	010FFh – 01000h	010FFh – 01000h	010FFh – 01000h	010FFh – 01000h
Boot memory	Size	1kB	1kB	1kB	1kB	1kB
	ROM	0FFFh – 0C00h	0FFFh – 0C00h	0FFFh – 0C00h	0FFFh – 0C00h	0FFFh – 0C00h
RAM	Size	256 Byte	512 Byte	1kB	2kB	2kB
		02FFh – 0200h	03FFh – 0200h	05FFh – 0200h	09FFh – 0200h	09FFh – 0200h
Peripherals	16-bit	01FFh – 0100h	01FFh – 0100h	01FFh – 0100h	01FFh – 0100h	01FFh – 0100h
	8-bit	0FFh – 010h	0FFh – 010h	0FFh – 010h	0FFh – 010h	0FFh – 010h
	8-bit SFR	0Fh – 00h	0Fh – 00h	0Fh – 00h	0Fh – 00h	0Fh – 00h

## boot ROM containing bootstrap loader

The intention of the bootstrap loader is to download data into the flash memory module. Various write, read, and erase operations are needed for a proper download environment. The bootstrap loader is only available on F devices.

### functions of the bootstrap loader:

- Definition of read:      Apply and transmit data of peripheral registers or memory to pin P1.1 (BSLTX)
- write:                      Read data from pin P2.2 (BSLRX) and write them into flash memory

### unprotected functions

Mass erase, erase of the main memory (segment 0 to segment n) and information memory (segment A and segment B)

Access to the MSP430 via the bootstrap loader is protected. It must be enabled before any protected function can be performed. The 256 bits in 0FFE0h to 0FFFFh provide the access key.

PRODUCT PREVIEW

---

## boot ROM containing bootstrap loader (continued)

### *protected functions*

All protected functions can be executed only if the access is enabled.

- Write/program byte into flash memory; Parameters passed are start address and number of bytes (the segment-write feature of the flash memory is not supported and not useful with the UART protocol).
- Segment erase of segment 0 to segment n in main memory, and segment erase of segments A and B in the information memory.
- Read all data in main memory and information memory.
- Read and write to all byte peripheral modules and RAM.
- Modify PC and start program execution immediately.

#### **NOTE:**

Unauthorized readout of code and data is prevented by the user's definition of the data in the interrupt memory locations.

### features of the bootstrap loader are:

- UART communication protocol, fixed to 9600 baud
- Port pin P1.1 for transmit, P2.2 for receive
- TI standard serial protocol definition
- Implemented in flash memory version only
- Program execution starts with the user vector at 0FFFFh or with the bootstrap loader (start vector is at address 0C00h)

### hardware resources used for serial input/output:

- Pins P1.1 and P2.2 for serial data transmission
- Test and  $\overline{\text{RST}}$ / $\overline{\text{NMI}}$  to start program execution at the reset or bootstrap loader vector
- Basic clock module: Rsel=5, DCO=4, MOD=0, DCOCLK for MCLK and SMCLK, clock divider for MCLK and SMCLK at default: dividing by 1
- Timer\_A: Timer\_A operates in continuous mode with MCLK source selected, input divider set to 1, using CCR0, and polling of CCIFG0.
- WDT: Watchdog timer is halted
- Interrupt: GIE=0, NMIIE=0, OFIFG=0, ACCVIFG=0
- Memory allocation and stack pointer:  
If the stack pointer points to RAM addresses above 0220h, 6 bytes of the stack are allocated, plus RAM addresses 0200h to 0219h. Otherwise the stack pointer is set to 0220h and allocates RAM from 0200h to 021Fh.

#### **NOTE:**

When writing RAM data via the bootstrap loader, make sure that the stack is outside the range of the data to be written.

# MSP430x13x, MSP430x14x MIXED SIGNAL MICROCONTROLLER

SLAS272A – JULY 2000 – REVISED JULY 2000

## boot ROM containing bootstrap loader (continued)

Program execution begins with the user's reset vector at FFFEh (standard method) if TCK is held high while RST/NMI goes from low to high:

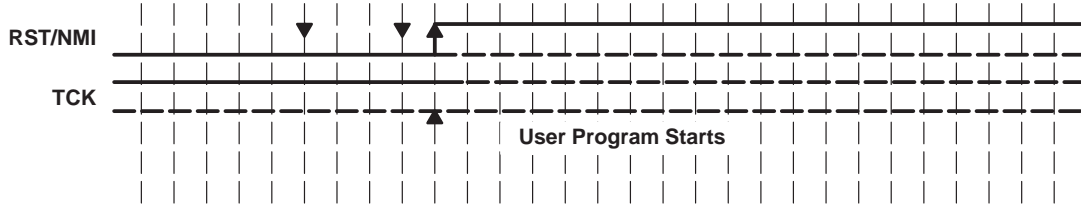

Program execution begins with the bootstrap vector at 0C00h (boot ROM) if a minimum of two negative edges have been applied to TCK while RST/NMI is low, and TCK is low when RST/NMI goes from low to high.

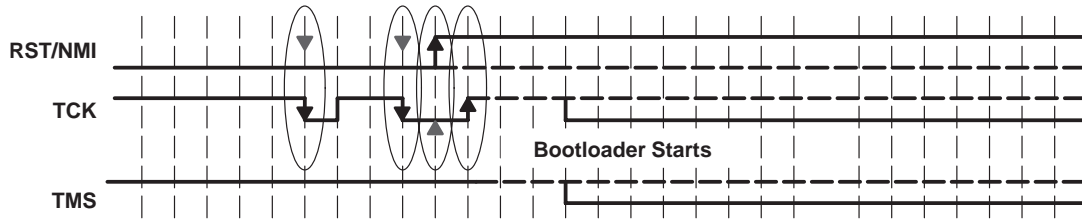

The bootstrap loader will not start (via the vector in address 0C00h) if:

- There are less than two negative edges at TCK while RST/NMI is low
- TCK is high when RST/NMI goes from low to high
- JTAG has control over the MSP430 resources
- The supply voltage VCC drops and a POR is executed

- NOTES:
6. The default level of TCK is high. An active low has to be applied to enter the bootstrap loader. Other MSP430s which have a pin function used with a low default level can use an inverted signal.
  7. The TMS signal must be high while TCK clocks are applied. This ensures that the JTAG controller function remains in its default mode.

### WARNING:

The bootstrap loader starts correctly only if the RST/NMI pin is in reset mode. Unpredictable program execution may result if it is switched to the NMI function. However, a bootstrap load may be started using software and the bootstrap vector, for example using the instruction BR &0C00h.

---

## flash memory

- Flash memory has n segments of main memory and two segments of information memory (A and B) of 128 bytes each. Each segment in main memory is 512 bytes in size.
- Segments 0 to n may be erased in one step, or each segment may be individually erased.
- Segments A and B can be erased individually, or as a group with segments 0–n. Segments A and B are also called *information memory*.
- A security fuse burning is irreversible; no further access to JTAG is possible afterwards
- Internal generation of the programming/erase voltage: no external  $V_{PP}$  has to be applied, but  $V_{CC}$  increases the supply current requirements.
- Program and erase timing is controlled by hardware in the flash memory – no software intervention is needed.
- The control hardware is called the flash-timing generator. The input frequency of the flash–timing generator should be in the proper range and should be maintained until the write/program or erase operation is completed.
- During program or erase, no code can be executed from flash memory and all interrupts must be disabled by setting the GIE, NMIIIE, ACCVIE, and OFIE bits to zero. If a user program requires execution concurrent with a flash program or erase operation, the program must be executed from memory other than the flash memory (e.g., boot ROM, RAM). In the event a flash program or erase operation is initiated while the program counter is pointing to the flash memory, the CPU will execute JMP \$ instructions until the flash program or erase operation is completed. Normal execution of the previously running software then resumes.
- Unprogrammed, new devices may have some bytes programmed in the information memory (needed for test during manufacturing). The user should perform an erase of the information memory prior to first use.

# MSP430x13x, MSP430x14x MIXED SIGNAL MICROCONTROLLER

SLAS272A – JULY 2000 – REVISED JULY 2000

## flash memory (continued)

8 kB	16 kB	32 kB	48 kB	60 kB	
0FFFFh	0FFFFh	0FFFFh	0FFFFh	0FFFFh	Segment 0 w/ Interrupt Vectors
0FE00h 0FDFFh	0FE00h 0FDFFh	0FE00h 0FDFFh	0FE00h 0FDFFh	0FE00h 0FDFFh	Segment 1
0FC00h 0FBFFh	0FC00h 0FBFFh	0FC00h 0FBFFh	0FC00h 0FBFFh	0FC00h 0FBFFh	Segment 2
0FA00h 0F9FFh	0FA00h 0F9FFh	0FA00h 0F9FFh	0FA00h 0F9FFh	0FA00h 0F9FFh	⋮
0E400h 0E3FFh	0C400h 0C3FFh	08400h 083FFh	04400h 043FFh	01400h 013FFh	Segment n-1
0E200h 0E1FFh	0C200h 0C1FFh	08200h 081FFh	04200h 041FFh	01200h 011FFh	Segment n
0E000h 010FFh	0C000h 010FFh	08000h 010FFh	04000h 010FFh	01100h 010FFh	Segment A
01080h 0107Fh	01080h 0107Fh	01080h 0107Fh	01080h 0107Fh	01080h 0107Fh	Segment B
01000h	01000h	01000h	01000h	01000h	

Main  
Memory

Information  
Memory

PRODUCT PREVIEW

## flash memory, control register FCTL1

All control bits are reset during PUC. PUC is active after application of  $V_{CC}$ , application of a reset condition to the RST/NMI pin, expiration of the Watchdog Timer, occurrence of a watchdog access violation, or execution of an improper flash operation. A more detailed description of the control-bit functions is found in the flash-memory module description (in the MSP430x1xx user's guide, literature number SLAU049). Any write to control register FCTL1 during erase, mass erase, or write (programming) will end in an access violation with ACCVIFG=1. In an active segment-write mode the control register can be written if the wait mode is active (WAIT=1). Special conditions apply during segment-write mode. See the MSP430x1xx user's guide for details.

Read access is possible at any time without restrictions.

The bits of control register FCTL1 are:

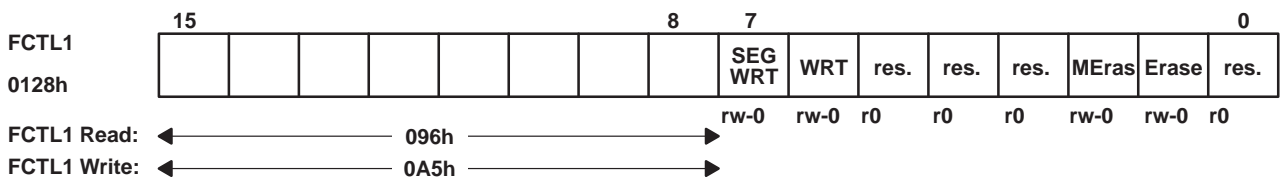

Erase	0128, bit1	Erase a segment 0: No segment erase will be started. 1: Erase of one segment is enabled. The segment to be erased is defined by a <i>dummy</i> write into any address within the segment. The erase bit is automatically reset when the erase operation is completed. See Note 7 below.
MEras	0128h, bit2	Mass erase, Segment0 to Segmentn are erased together. 0: No erase will be started 1: Erase of Segment0 to Segmentn is enabled. A dummy write to any address in Segment0 to Segmentn starts mass erase. The MEras bit is automatically reset when the erase operation is completed. See Note 7 below.
WRT	0128h, bit6	Bit WRT should be set for a successful write operation. An access violation occurs and ACCVIFG is set if bit WRT is reset and write access to the flash memory is performed. See Note 7 below.
SEGWRT	0128h, bit7	Bit SEGWRT may be used to reduce total programming time. Segment-write bit SEGWRT is useful when larger sequences of data have to be programmed. After completion of programming of one segment, a reset and set sequence has to be performed to enable access to the next segment. The WAIT bit must be high before executing the next write instruction. 0: No segment write accelerate is selected. 1: Segment write is used. This bit needs to be reset and set between segment borders.

NOTE 8: Only instruction-fetch access is allowed during program, erase, or mass-erase cycles. Any other access to the flash memory during these cycles will result in setting the ACCVIFG bit. An NMI interrupt should handle such violations.

# MSP430x13x, MSP430x14x MIXED SIGNAL MICROCONTROLLER

SLAS272A – JULY 2000 – REVISED JULY 2000

## flash memory, control register FCTL1 (continued)

**Table 3. Valid Combinations of Control Bits for Flash Memory Access (see Note 9)**

FUNCTION PERFORMED	SEGWRT	WRT	MERAS	ERASE	BUSY	WAIT	LOCK
Write word or byte	0	1	0	0	0	0	0
Write word or byte in same segment, segment write mode	1	1	0	0	0	1	0
Erase one segment by writing to any address in the target segment	0	0	0	1	0	0	0
Erase all segments (0 to n) but not the information memory (segments A and B)	0	0	1	0	0	0	0
Erase all segments (0 to n, and A and B) by writing to any address in the flash memory module	0	0	1	1	0	0	0

NOTE 9: The table shows all possible combinations of control bits SEGWRT, WRT, MERas, Erase, and BUSY. All other combinations will result in an access violation.

## flash memory, the timing generator, control register FCTL2

The timing generator (Figure 1) produces all the timing signals necessary for write, erase, and mass erase from the selected clock source. One of three different clock sources may be selected by control bits SSEL0 and SSEL1 in control register FCTL2. The selected clock source should be divided to meet the frequency requirements specified in the recommended operating conditions.

The flash-timing generator is reset with PUC. It is also reset if the emergency exit bit EMEX is set. Control register FCTL2 may not be written to if the BUSY bit is set; otherwise, an access violation will occur (ACCVIFG=1).

Read access is possible at any time without restrictions.

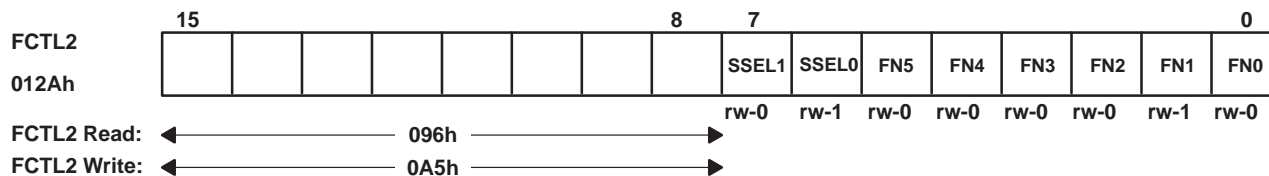

The control bits are:

- FN0 to FN5    012Ah, bit0 to bit5    These six bits determine the division rate of the clock signal. The division rate is 1 to 64, depending on the value of FN5 to FN0 plus one.
- SSEL0    012Ah, bit0    Determine the clock source
- SSEL1    0: ACLK  
          1: MCLK  
          2: SMCLK  
          3: SMCLK

PRODUCT PREVIEW

### flash memory control register FCTL3

There are no restrictions on modifying this control register. The control bits are reset or set (WAIT) by a PUC, but key violation bit KEYV is reset with a POR.

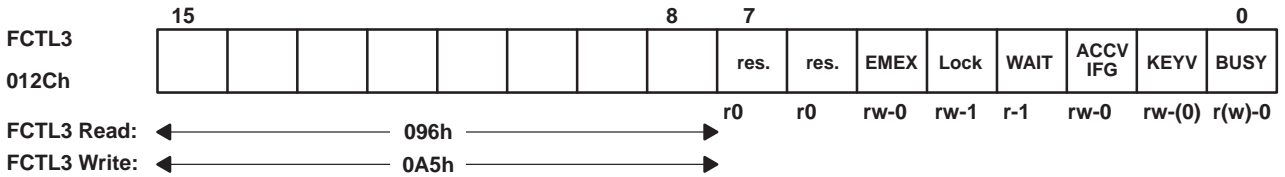

BUSY	012Ch, bit0	The BUSY bit shows if an access to the flash memory is correct (BUSY=0), or if an access violation has taken place. The BUSY bit should be tested before each write and erase cycle. 0: Flash memory is not busy. 1: Flash memory is busy. It remains in busy state if segment-write function is in <i>wait</i> mode.
KEYV,	012Ch, bit1	Key violated 0: Key 0A5h (high byte) was not violated. 1: Key 0A5h (high byte) was violated. Violation occurs when a write access to register FCTL1, FCTL2, or FCTL3 is executed and the <i>high byte</i> is not equal to 0A5h. If the security key is violated, bit KEYV is set and a PUC is performed.
ACCVIFG,	012Ch, bit2	Access-violation interrupt flag The access-violation interrupt flag is set only when a write or erase operation is active. Access violation can only happen if the flash-memory module is written or read while it is busy. An instruction can be fetched during write, erase, and mass erase, but not during segment write. When the access-violation interrupt-enable bit is set, the interrupt-service request is accepted and the program continues at the NMI interrupt-vector address. Reading the control registers will not set the ACCVIFG bit.
WAIT,	012Ch, bit3	In the segment-write mode, the WAIT bit indicates that the flash memory is prepared to receive the (next) data for programming. The WAIT bit is read only, but a write to WAIT bit is allowed. 0: Segment-write operation is started and programming is in progress 1: Segment write operation is active and programming of data has been completed
Lock	012Ch, bit4	The lock bit may be set during any write, erase of a segment, or <i>mass</i> erase request. The active sequence is completed normally. In segment-write mode, the SEGWRT and WAIT bits are reset and the mode ends in the regular manner. The software or hardware controls the lock bit. If an access violation occurs during segment-write mode, the ACCVIFG and LOCK bits may be set. 0: Flash memory may be read, programmed, erased, and <i>mass</i> erased. 1: Flash memory may be read but not programmed, erased, and <i>mass</i> -erased. A current program, erase, or <i>mass</i> -erase operation will complete normally. The access-violation interrupt flag ACCVIFG is set when the flash-memory module is accessed while the lock bit is set.
EMEX,	012Ch, bit5	Emergency exit. The emergency exit should only be used if a flash memory write or erase operation is out of control. 0: No function 1: Stops the active operation immediately and shuts down all internal parts in the flash memory controller. Current consumption immediately drops back to the active mode level. All bits in control register FCTL1 are reset. Since the EMEX bit is automatically reset by hardware, the software always reads EMEX as 0.

# MSP430x13x, MSP430x14x MIXED SIGNAL MICROCONTROLLER

SLAS272A – JULY 2000 – REVISED JULY 2000

## flash memory, interrupt and security key violation

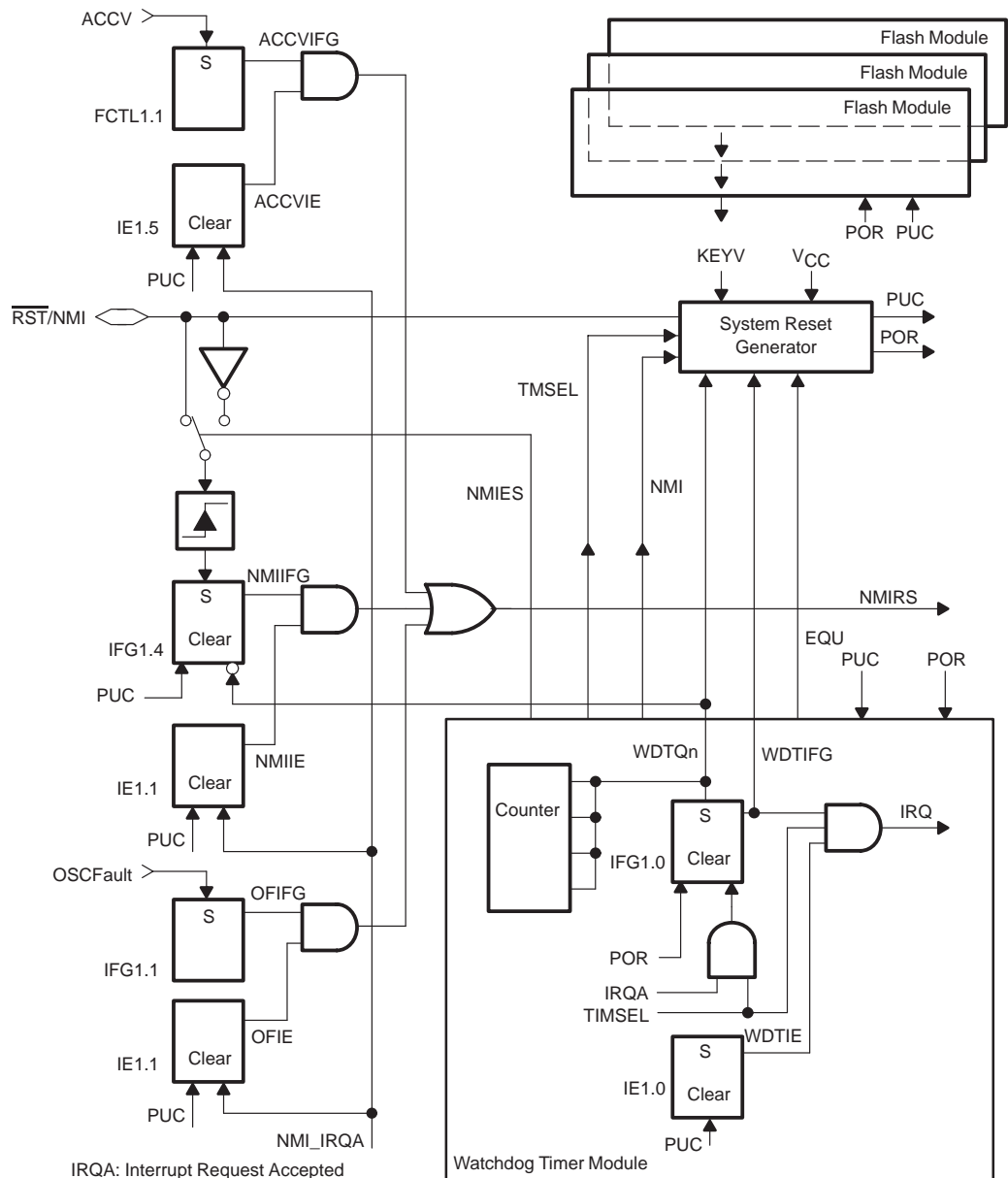

Figure 1. Block Diagram of NMI Interrupt Sources

One NMI vector is used for three NMI events:  $\overline{\text{RST/NMI}}$  (NMIIFG), oscillator fault (OFIFG), and flash memory access violation (ACCVIFG). The software can determine the source of the interrupt request, since all flags remain set until reset by software. The enable flag(s) should be set only within one instruction directly before the return-from-interrupt (RETI) instruction. This ensures that the stack remains under control. A pending NMI interrupt request will not increase stack demand unnecessarily.

PRODUCT PREVIEW

## peripherals

Peripherals are connected to the CPU through data, address, and control busses, and can be easily handled using all memory-manipulation instructions.

## oscillator and system clock

Three clocks are used in the system—the main system (master) clock (MCLK) used by the CPU and the system, the subsystem (master) clock (SMCLK) used by the peripheral modules, and the auxiliary clock (ACLK) originated by LFXT1CLK (crystal frequency) and used by the peripheral modules.

Following a POR the DCOCLK is used by default, the DCOR bit is reset, and the DCO is set to the nominal initial frequency. Additionally, if either LFXT1CLK or XT2CLK fails as the source for MCLK, DCOCLK is automatically selected to ensure fail-safe operation.

SMCLK can be generated from XT2CLK or DCOCLK. ACLK is always generated from LFXT1CLK.

Crystal oscillator LFXT1 can be defined to operate with watch crystals (32,768 Hz) or with higher-frequency ceramic resonators or crystals. The crystal or ceramic resonator is connected across two terminals. No external components are required for watch-crystal operation. If the high-frequency XT1 mode is selected, external capacitors from XIN to VSS and XOUT to VSS are required, as specified by the crystal manufacturer.

The LFXT1 oscillator starts after application of VCC. If the OscOff bit is set to 1, the oscillator stops when it is not used for MCLK.

Crystal oscillator XT2 is identical to oscillator LFXT1, but only operates with higher-frequency ceramic resonators or crystals. The crystal or ceramic resonator is connected across two terminals. External capacitors from XT2IN to VSS and XT2OUT to VSS are required as specified by the crystal manufacturer.

The XT2 oscillator is off after application of VCC, since the XT2 oscillator control bit XT2Off is set. If bit XT2Off is set to 1, the XT2 oscillator stops when it is not used for MCLK.

Clock signals ACLK, MCLK, and SMCLK may be used externally via port pins.

Different application requirements and system conditions dictate different system-clock requirements, including:

- High frequency for quick reaction to system hardware requests or events
- Low frequency to minimize current consumption, EMI, etc.
- Stable peripheral clock for timer applications, such as real-time clock (RTC)
- Start-stop operation that can be enabled with minimum delay

## multiplication

The multiplication operation is supported by a dedicated peripheral module. The module performs 16x16, 16x8, 8x16, and 8x8 bit operations. The module is capable of supporting signed and unsigned multiplication as well as signed and unsigned multiply and accumulate operations. The result of an operation can be accessed immediately after the operands have been loaded into the peripheral registers. No additional clock cycles are required.

## digital I/O

There are six 8-bit I/O ports implemented—ports P1 through P6. Ports P1 and P2 use seven control registers, while ports P3, P4, P5, and P6 use only four of the control registers to provide maximum digital input/output flexibility to the application:

- All individual I/O bits are independently programmable.
- Any combination of input, output, and interrupt conditions is possible.
- Interrupt processing of external events is fully implemented for all eight bits of ports P1 and P2.
- Read/write access to all registers using all instructions is possible.

# MSP430x13x, MSP430x14x MIXED SIGNAL MICROCONTROLLER

SLAS272A – JULY 2000 – REVISED JULY 2000

---

## digital I/O (continued)

The seven control registers are:

- Input register 8 bits at ports P1 through P6
- Output register 8 bits at ports P1 through P6
- Direction register 8 bits at ports P1 through P6
- Interrupt edge select 8 bits at ports P1 and P2
- Interrupt flags 8 bits at ports P1 and P2
- Interrupt enable 8 bits at ports P1 and P2
- Selection (port or module) 8 bits at ports P1 through P6

Each one of these registers contains eight bits. Two interrupt vectors are implemented: one commonly used for any interrupt event on ports P1.0 to P1.7, and another commonly used for any interrupt event on ports P2.0 to P2.7.

Ports P3, P4, P5, and P6 have no interrupt capability.

## Watchdog Timer

The primary function of the Watchdog Timer (WDT) module is to perform a controlled system restart after a software upset has occurred. A system reset is generated if the selected time interval expires. If an application does not require this watchdog function, the module can work as an interval timer, which generates an interrupt after a selected time interval.

The Watchdog Timer counter (WDTCNT) is a 15/16-bit up-counter not directly accessible by software. The WDTCNT is controlled using the Watchdog Timer control register (WDTCTL), which is an 8-bit read/write register. Writing to WDTCTL in either operating mode (watchdog or timer) is only possible when using the correct password (05Ah) in the high-byte. If any value other than 05Ah is written to the high-byte of the WDTCTL, a system reset PUC is generated. The password is read as 069h to minimize accidental write operations to the WDTCTL register. The low-byte stores data written to the WDTCTL. In addition to the Watchdog Timer control bits, there are two bits included in the WDTCTL that configure the NMI pin.

## USART0 and USART1

There are two USART peripherals implemented in the MSP430x14x: USART0 and USART1; but only one in the MSP430x13x configuration: USART0. Both have an identical function as described in the applicable chapters of the *MSP430x1xx User's Guide*. They use different pins to communicate, and different registers for module control. Registers with identical functions have different addresses.

The universal synchronous/asynchronous interface is a dedicated peripheral module used in serial communications. The USART supports synchronous SPI (3- or 4-pin), and asynchronous UART communication protocols, using double-buffered transmit and receive channels. Data streams of 7 or 8 bits in length can be transferred at a rate determined by the program, or by an external clock. Low-power applications are optimized by UART mode options which allow for the reception of only the first byte of a complete frame. The application software should then decide if the succeeding data is to be processed. This option reduces power consumption.

Two dedicated interrupt vectors are assigned to each USART module—one for the receive and one for the transmit channels.

**timer\_A (three capture/compare registers)**

The timer module offers one sixteen-bit counter and three capture/compare registers. The timer clock source can be selected from an external source TACLK (SSEL=0 or 3), or from two internal sources—ACLK (SSEL=1) or SMCLK (SSEL=2). The clock source can be divided by one, two, four, or eight. The timer can be fully controlled (in word mode)—it can be halted, read, and written; it can be stopped, run continuously, or made to count up or up/down using one compare block to determine the period. The three capture/compare blocks are configured by the application to run in capture or compare mode.

The capture mode is mostly used to individually measure internal or external events from any combination of positive, negative, or positive and negative edges. It can also be stopped by software. Three different external events can be selected: TA0, TA1, and TA2. In the capture/compare register CCR2, ACLK is the capture signal if CCI2B is selected. Software capture is chosen if CCISx=2 or CCISx=3.

The compare mode is mostly used to generate timing for the software or application hardware, or to generate pulse-width modulated output signals for various purposes like D/A conversion functions or motor control. An individual output module is assigned to each of the three capture/compare registers. This module can run independently of the compare function or can be triggered in several ways.

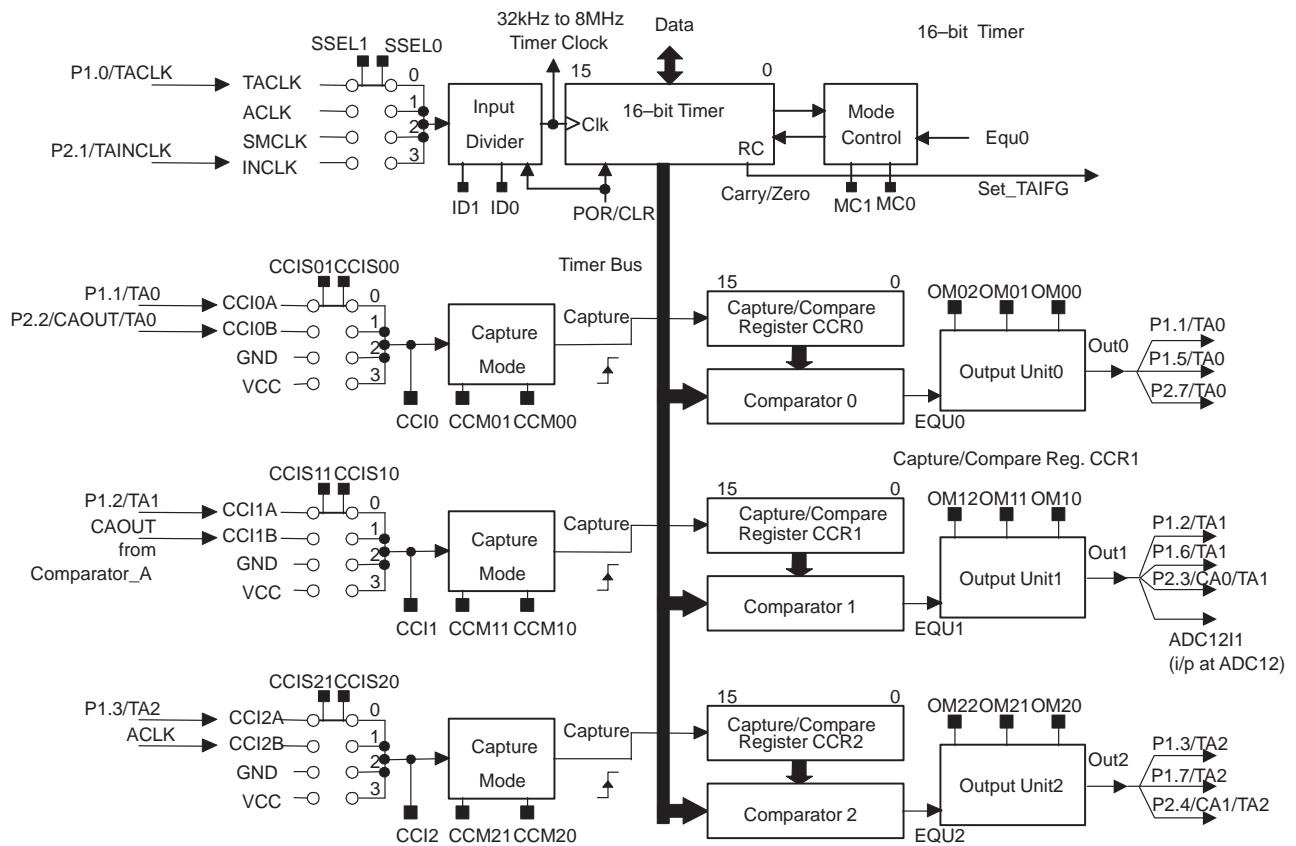

**Figure 2. Timer\_A, MSP430x13x/14x Configuration**

Two interrupt vectors are used by the module. One vector is assigned to capture/compare block CCR0, and one common-interrupt vector is implemented for the timer and the other two capture/compare blocks. The three interrupt events using the same vector are identified by an individual interrupt vector word. The interrupt vector word is used to add an offset to the program counter so that the interrupt handler software continues at the corresponding program location. This simplifies the interrupt handler and assigns each interrupt event the same five-cycle overhead.

# MSP430x13x, MSP430x14x MIXED SIGNAL MICROCONTROLLER

SLAS272A – JULY 2000 – REVISED JULY 2000

---

## timer\_B (7 capture/compare registers in 'x14x and 3 capture/compare registers in 'x13x)

Timer\_B7 is identical to Timer\_A3, except for the following:

- The timer counter can be configured to operate in 8-, 10-, 12-, or 16-bit mode.
- The function of the capture/compare registers is slightly different when in compare mode. In Timer\_B, the compare data is written to the capture/compare register, but is then transferred to the associated compare latch for the comparison.
- All output level Outx can be set to Hi-Z from the TboutH external signal.
- The SCCI bit is not implemented in Timer\_B
- Timer\_B7 has seven capture compare registers

The timer module has one sixteen-bit counter and seven capture/compare registers. The timer clock source can be selected from an external source TBCLK (SSEL=0 or 3), or from two internal sources: ACLK (SSEL=1) and SMCLK (SSEL=2)). The clock source can be divided by one, two, four, or eight. The timer can be fully controlled (in word mode): it can be halted, read, and written; it can be stopped, run continuously, or made to count up or up/down using one compare block to determine the period. The seven capture/compare blocks are configured by the application to run in capture or in compare mode.

The capture mode is mostly used to measure external or internal events from any combination of positive, negative, or positive and negative edges. It can also be stopped by software. Any of seven different external events TB0 to TB6 can be selected. In the capture/compare register CCR6, ACLK is the capture signal if CCI6B is selected. Software capture is chosen if CCISx=2 or CCISx=3.

The compare mode is mostly used to generate timing for the software or application hardware, or to generate pulse-width modulated output signals for various purposes such as D/A conversion functions or motor control. An individual output module is assigned to each of the seven capture/compare registers. This module can run independently of the compare function, or can be triggered in several ways. The comparison is made from the data in the compare latches (TBCLx) and not from the compare register.

Two interrupt vectors are used by the module. One vector is assigned to capture/compare block CCR0, and one common interrupt vector is implemented for the timer and the other six capture/compare blocks. The seven interrupt events using the same vector are identified by an individual interrupt vector word. The interrupt vector word is used to add an offset to the program counter so that the interrupt handler software continues at the corresponding program location. This simplifies the interrupt handler and assigns each interrupt event the same five-cycle overhead.

### compare latches (TBCLx)

The compare latches can be loaded directly by software or via selected conditions triggered by the PWM function. They are reset by the POR signal.

Load TBCLx immediate, CLLD=0:	Capture/compare register CCRx and the corresponding compare latch are loaded simultaneously.
Load TBCLx at Zero, CLLD=1:	The data in capture/compare register CCRx is loaded to the corresponding compare latch when the 16-bit timer TBR counts to zero.
Load TBCLx at Zero + Period, CLLD=2:	The data in capture/compare register CCRx is loaded to the corresponding compare latch when the 16-bit timer TBR counts to zero or when the next period starts (in UP/DOWN mode).
Load TBCLx at EQUx, CLLD=3:	The data in capture/compare register CCRx is loaded when CCRx is equal to TBR.

Loading the compare latches can be done individually or in groups. Individually means that whenever the selected load condition (see above) is true, the CCRx data is loaded into TBCLx.

Load TBCLx individually, TBCLGRP=0:	Compare latch TBCLx is loaded when the selected load condition (CLLD) is true.
Dual load TBCLx mode, TBCLGRP=1:	Two compare latches TBCLx are loaded when data are written to both CCRx registers of the same group and the load condition (CLLD) is true. Three groups are defined: CCR1+CCR2, CCR3+CCR4, and CCR5+CCR6.
Triple load TBCLx mode, TBCLGRP=2:	Three compare latches TBCLx are loaded when data are written to all CCRx registers of the same group and then the selected load condition (CLLD) is true. Two groups are defined: CCR1+CCR2+CCR3 and CR4+CCR5+CCR6.
Full load TBCLx mode, TBCLGRP=3:	All seven compare latches TBCLx are loaded when data are written to all seven CCRx registers and then the selected load condition (CLLD) is true. All CCRx data, CCR0+CCR1+CCR2+CCR3+CCR4+CCR5+CCR6, are simultaneously loaded to the corresponding SHRx compare latches.

# MSP430x13x, MSP430x14x MIXED SIGNAL MICROCONTROLLER

SLAS272A – JULY 2000 – REVISED JULY 2000

## compare latches (TBCLx) (continued)

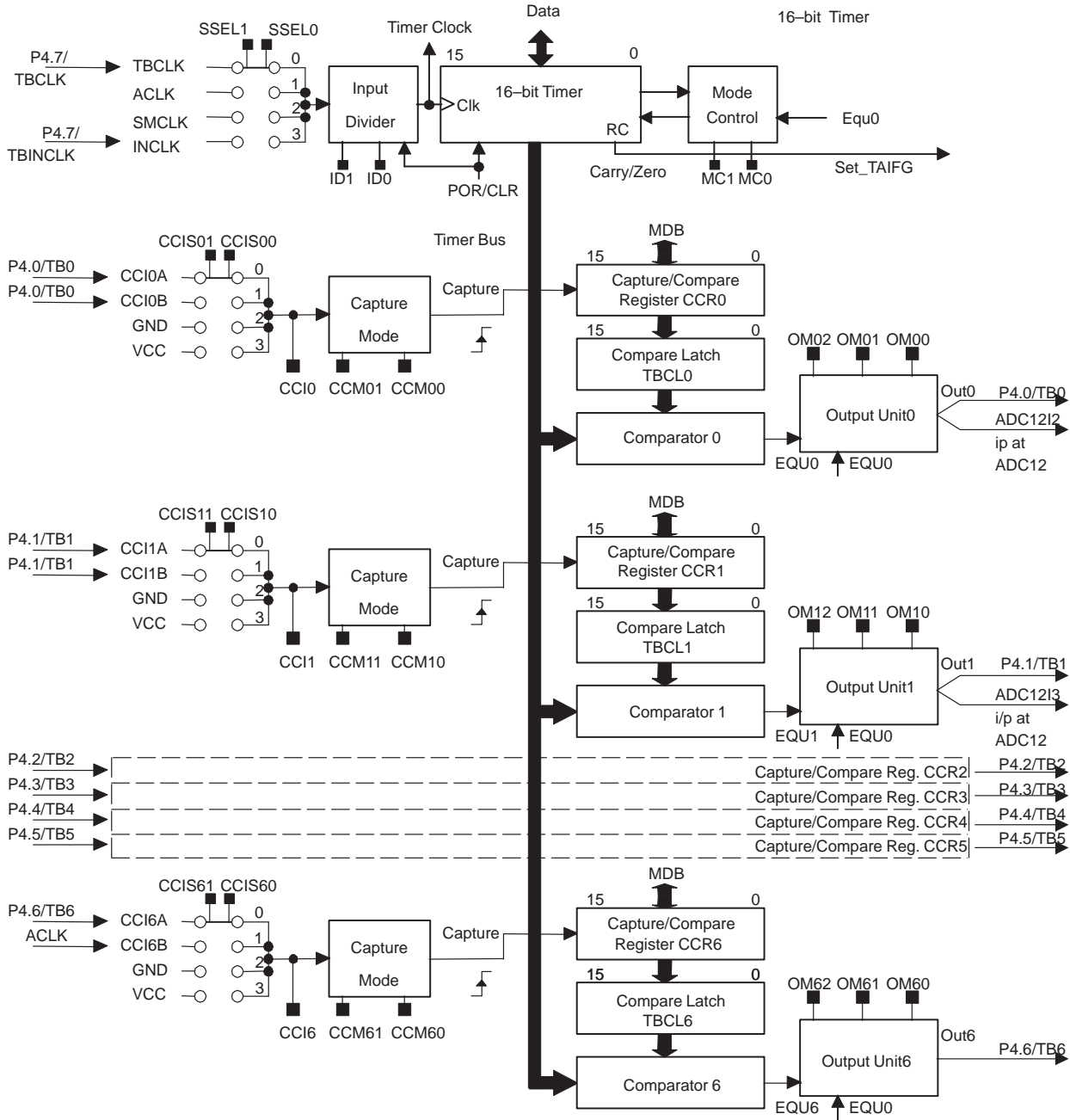

PRODUCT PREVIEW

# MSP430x13x, MSP430x14x MIXED SIGNAL MICROCONTROLLER

SLAS272A – JULY 2000 – REVISED JULY 2000

## comparator\_A

The primary functions of the comparator module are support of precision slope conversion in A/D applications, battery voltage supervision, and external analog signal monitoring. The comparator is connected to port pins P2.3 (+ terminal) and to P2.4 (–terminal). It is controlled via eight control bits in the CACTL register.

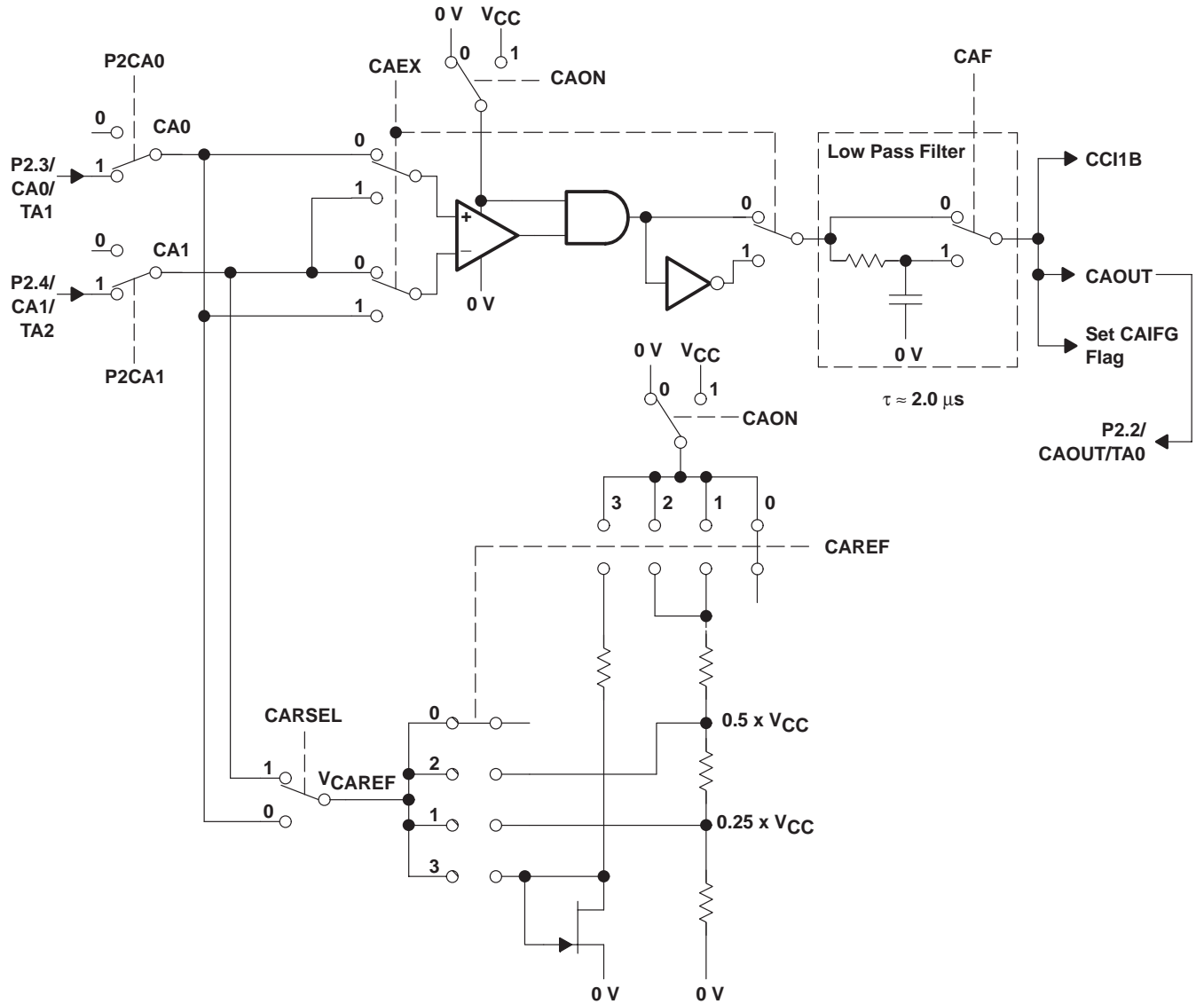

PRODUCT PREVIEW

# MSP430x13x, MSP430x14x MIXED SIGNAL MICROCONTROLLER

SLAS272A – JULY 2000 – REVISED JULY 2000

## comparator\_A

The control bits are:

CAOUT,	05Ah, bit0	Comparator output
CAF,	05Ah, bit1	The comparator output is transparent or fed through a small filter
P2CA0,	05Ah, bit2	0: Pin P2.3/CA0/TA1 is not connected to Comparator_A. 1: Pin P2.3/CA0/TA1 is connected to Comparator_A.
P2CA1,	05Ah, bit3	0: Pin P2.4/CA1/TA2 is not connected to Comparator_A. 1: Pin P2.4/CA1/TA2 is connected to Comparator_A.
CACTL2.4	05Ah, bit4	Bits are implemented but do not control any hardware in this device.
to		
CATCTL2.7	05Ah, bit7	
CAIFG,	059h, bit0	Comparator_A interrupt flag
CAIE,	059h, bit1	Comparator_A interrupt enable
CAIES,	059h, bit2	Comparator_A interrupt edge select bit 0: The rising edge sets the Comparator_A interrupt flag CAIFG 1: The falling edge set the Comparator_A interrupt flag CAIFG
CAON,	059h, bit3	The comparator is switched on.
CAREF,	059h, bit4,5	Comparator_A reference 0: Internal reference is switched off, an external reference can be applied. 1: $0.25 \times V_{CC}$ reference selected. 2: $0.50 \times V_{CC}$ reference selected. 3: A diode reference selected.
CARSEL,	059h, bit6	An internal reference $V_{CAREF}$ , selected by CAREF bits, can be applied to signal path CA0 or CA1. The signal $V_{CAREF}$ is only driven by a voltage source if the value of CAREF control bits is 1, 2, or 3.
CAEX,	059h, bit7	The comparator inputs are exchanged, used to measure and compensate the offset of the comparator.

Eight additional bits are implemented into the Comparator\_A module. They enable the software to switch off the input buffer of Port P2. A CMOS input buffer can dissipate supply current when the input is not near  $V_{SS}$  or  $V_{CC}$ . Control bits CAIP0 to CAIP7 are initially reset and the port input buffer is active. The port input buffer is inactive if the corresponding control bit is set.

## A/D converter

The 12-bit analog-to-digital converter (ADC) uses a 10-bit weighted capacitor array plus a 2-bit resistor string. The CMOS threshold detector in the successive-approximation conversion technique determines each bit by examining the charge on a series of binary-weighted capacitors. The features of the ADC are:

- 12-bit converter with  $\pm 1$  LSB differential (DNL) and  $\pm 1$  LSB integral nonlinearity (INL)
- Built-in sample-and-hold
- Eight external and four internal analog channels. The external ADC input terminals are shared with digital port I/O pins.
- Internal reference voltage  $V_{REF+}$  of 1.5 V or 2.5 V, software-selectable by control bit 2\_5V
- Internal-temperature diode for temperature measurement
- Battery-voltage measurement:  $N = 0.5 \times (AV_{CC} - AV_{SS}) \times 4096/1.5V$ ;  $V_{REF+}$  is selected for 1.5 V.

# MSP430x13x, MSP430x14x MIXED SIGNAL MICROCONTROLLER

SLAS272A – JULY 2000 – REVISED JULY 2000

## A/D converter (continued)

- Source of positive reference voltage level  $V_{R+}$  can be selected as internal (1.5 V or 2.5 V), external, or  $AV_{CC}$ . The source is selected individually for each channel.
- Source of negative reference voltage level  $V_{R-}$  can be selected as external or  $AV_{SS}$ . The source is selected individually for each channel.
- Conversion time can be selected from various clock sources: ACLK, MCLK, SMCLK, or the internal ADC12CLK oscillator. The clock source is divided by an integer from 1 to 8, as selected by software.
- Channel conversion: individual channels, a group of channels, or repeated conversion of a group of channels. If conversion of a group of channels is selected, the sequence, the channels, and the number of channels in the group can be defined by software. For example, a1-a2-a5-a2-a2-....
- The conversion is enabled by the ENC bit, and can be triggered by software via sample and conversion control bit ADC12SC, Timer\_A3, or Timer\_Bx. Most of the control bits can be modified only if ENC control bit is low. This prevents unpredictable results caused by unintended modification.
- Sampling time can be  $4 \times n_0 \times \text{ADC12CLK}$  or  $4 \times n_1 \times \text{ADC12CLK}$ . It can be selected to sample as long as the sample signal is high (ISSH=0) or low (ISSH=1). SHT0 defines  $n_0$  and SHT1 defines  $n_1$ .
- The conversion result is stored in one of sixteen registers. The sixteen registers have individual addresses and can be accessed via software. Each of the sixteen registers is linked to an 8-bit register that defines the positive and negative reference source and the channel assigned.

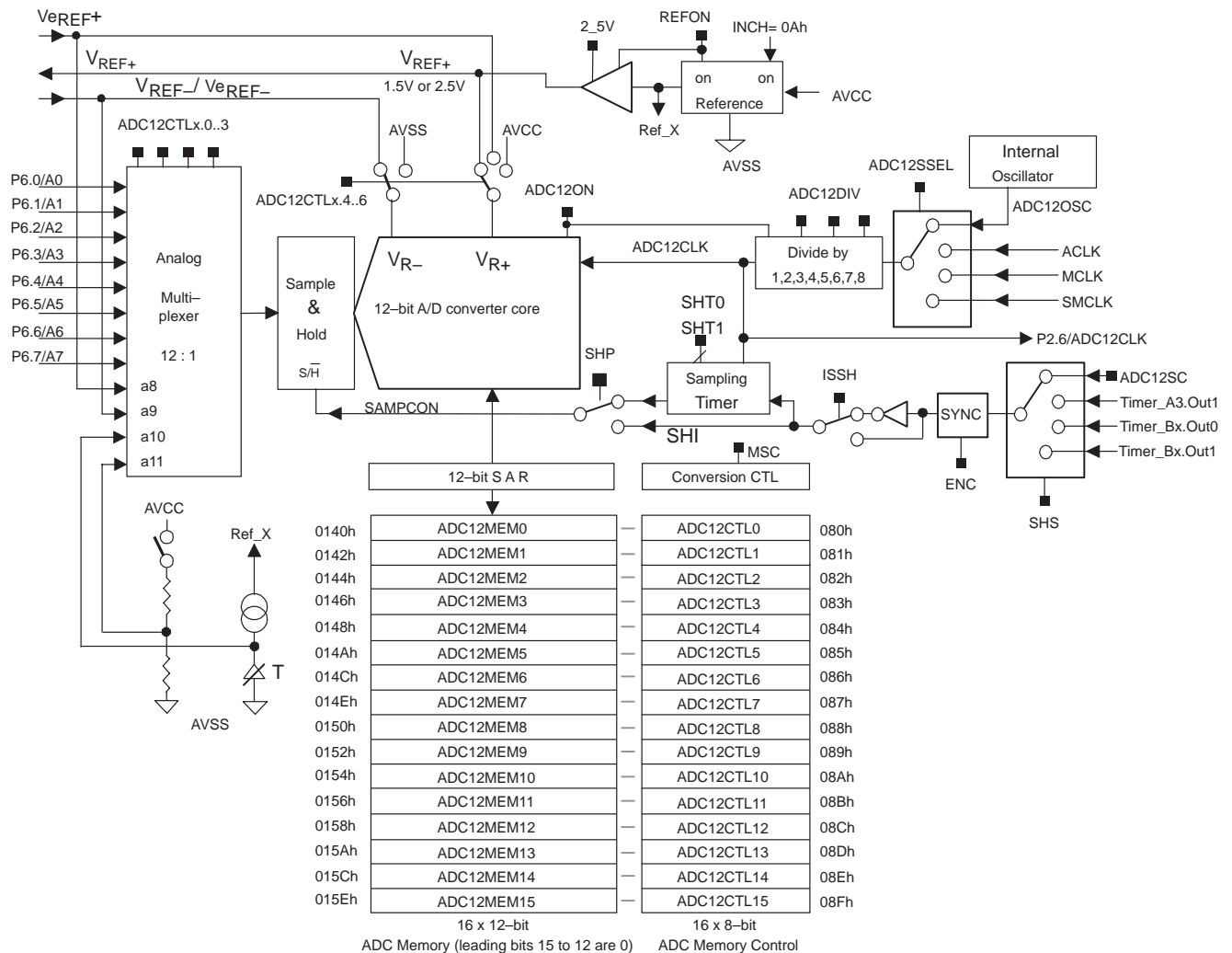

PRODUCT PREVIEW

# MSP430x13x, MSP430x14x MIXED SIGNAL MICROCONTROLLER

SLAS272A – JULY 2000 – REVISED JULY 2000

## A/D converter (continued)

**Table 4. Reference Voltage Configurations**

SREF	VOLTAGE AT VR+	VOLTAGE AT VR-
0	AV <sub>CC</sub>	AV <sub>SS</sub>
1	V <sub>REF+</sub> (internal)	AV <sub>SS</sub>
2, 3	V <sub>eREF+</sub> (external)	AV <sub>SS</sub>
4	AV <sub>CC</sub>	V <sub>REF-</sub> /V <sub>eREF-</sub> (internal or external)
5	V <sub>REF+</sub> (internal)	V <sub>REF-</sub> /V <sub>eREF-</sub> (internal or external)
6, 7	V <sub>eREF+</sub> (external)	V <sub>REF-</sub> /V <sub>eREF-</sub> (internal or external)

## control registers ADC12CTL0 and ADC12CTL1

All control bits are reset during POR. POR is active after V<sub>CC</sub> or a reset condition is applied to pin RST/NMI. A more detailed description of the control bit functions is found in the ADC12 module description (in the user's guide). Most of the control bits in registers ADC12CTL0, ADC12CTL1, and ADC12MCTLx can only be modified if ENC is low.

The following illustration highlights these bits. Six bits are excluded and can be unrestrictedly modified: ADC12SC, ENC, ADC12TOVIE, ADC12OVIE, and CONSEQ.

The control bits of control registers ADC12CTL0 and ADC12CTL1 are:

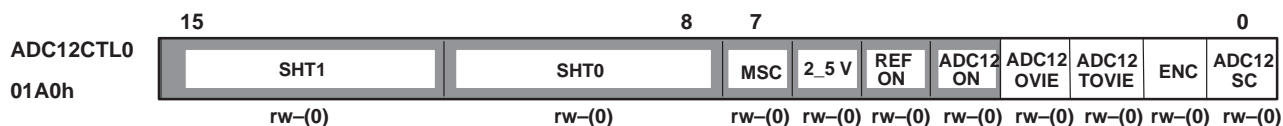

ADC12SC  
01A0h, bit0

Sample and convert. The ADC12SC bit is used to control the conversion by software. It is recommended that ISSH=0.

SHP=1: Changing the ADC12SC bit from 0 to 1 starts the sample and conversion operation. Bit ADC12SC is automatically reset when the conversion is complete (BUSY=0).

SHP=0: A high level of bit ADC12SC determines the sample time. Conversion starts once it is reset (by software). The conversion takes 13 ADC12CLK cycles.

ENC  
01A0h, bit1

Enable conversion. A conversion can be started by software (via ADC12SC) or by external signals, only if the enable conversion bit ENC is high. Most of the control bits in ADC12CTL0 and ADC12CTL1, and all the bits in ADCMCTL.x can only be changed if ENC is low.

0 :No conversion can be started. This is the initial state.

1: The first sample and conversion starts with the first rising edge of the sampling signal. The operation selected proceeds as long as ENC is set.

**control registers ADC12CTL0 and ADC12CTL1**

- ADC12TOVIE  
01A0h, bit2 Conversion time overflow interrupt enable.  
The timing overflow takes place and a timing overflow vector is generated if another start of sample and conversion is requested while the current conversion or sequence of conversions is still active. The timing overflow enable, if set, may request an interrupt.
- ADC12OVIE  
01A0h, bit3 Overflow interrupt enables the individual enable for the overflow-interrupt vector.  
The overflow takes place if the next conversion result is written into ADC memory ADC12MEMx but the previous result was not read. If an overflow vector is generated, the overflow-interrupt enable flag ADC12OVIE and the general-interrupt enable GIE are set and an interrupt service is requested.
- ADC12ON  
01A0h, bit4 Switch on the 12-bit ADC core. Make sure that the settling timing constraints are met if ADC core is powered up.  
0: Power consumption of the core is off. No conversion is started.  
1: ADC core is supplied with power. If no A/D conversion is required, ADC12ON can be reset to conserve power.
- REFON  
01A0h, bit5 Reference voltage on  
0: The internal reference voltage is switched off. No power is consumed by the reference voltage generator.  
1: The internal reference voltage is switched on and consumes additional power. The settling time of the reference voltage should be over before the first sample and conversion is started.
- 2\_5V  
01A0h, bit6 Reference voltage level  
0: The internal-reference voltage is 1.5 V if REFON = 1.  
1: The internal-reference voltage is 2.5 V if REFON = 1.
- MSC  
01A0h, bit7 Multiple sample and conversion. Works only when the sample timer is selected to generate the sample signal and to repeat single channel, sequence of channel, or when repeat sequence of channel (CONSEQ≠0) is selected.  
0 : Only one sample is taken.  
1 : If SHP is set and CONSEQ = {1, 2, or 3}, then the rising edge of the sample timer's input signal starts the repeat and/or the sequence of channel mode. Then the second and all further conversions are immediately started after the current conversion is completed.
- SHT0  
01A0h, bit8–11 Sample-and-hold Time0
- SHT1  
01A0h, bit12–15 Sample-and-hold Time1  
The sample time is a multiple of the ADC12CLK × 4:

$$t_{\text{sample}} = 4 \times \text{ADC12CLK} \times n$$

SHT0/1	0	1	2	3	4	5	6	7	8	9	10	11	12–15
n	1	2	4	8	16	24	32	48	64	96	128	192	256

The sampling time defined by SHT0 is used when ADC12MEM0 through ADC12MEM7 are used during conversion. The sampling time defined by SHT1 is used when ADC12MEM8 through ADC12MEM15 are used during conversion.

# MSP430x13x, MSP430x14x MIXED SIGNAL MICROCONTROLLER

SLAS272A – JULY 2000 – REVISED JULY 2000

## control registers ADC12CTL0 and ADC12CTL1 (continued)



- ADC12BUSY  
01A2h, bit0  
The BUSY signal indicates an active sample and conversion operation.  
0: No conversion is active. The enable conversion bit ENC can be reset normally.  
1: A sample period. Conversion or conversion sequence is active.
- CONSEQ  
01A2h, bit1/2  
Select the conversion mode. Repeat mode is on if CONSEQ.1 (bit 1) is set.  
0: One single channel is converted  
1: One single sequence of channels is converted  
2: Repeating conversion of one single channel  
3: Repeating conversion of a sequence of channels
- ADC12SSEL  
01A2h, bit3/4  
Selects the clock source for the converter core  
0: Internal oscillator embedded in the ADC12 module  
1: ACLK  
2: MCLK  
3: SMCLK
- ADC12DIV  
01A2h, bit5,6,7  
Selects the division rate for the clock source selected by ADC12SSEL. The clock-operation signal ADC12CLK is used in the converter core. The conversion, without sampling time, requires 13 ADC12CLK clocks.  
0 to 7: Divide selected clock source by integer from 1 to 8
- ISSH  
01A2h, bit8  
Invert source for the sample signal  
0: The source for the sample signal is not inverted.  
1: The source for the sample signal is inverted.
- SHP  
01A2h, bit9  
Sample-and-hold pulse, programmable length of sample pulse  
0: The sample operation lasts as long as the sample-and-hold signal is 1. The conversion operation starts if the sample-and-hold signal goes from 1 to 0.  
1: The sample time (sample signal is high) is defined by  $n \times 4 \times (1/f_{ADC12CLK})$ . SHTx holds the data for n. The conversion starts when the sample signal goes from 1 to 0.
- SHS  
01A2h, bit10/11  
Source for sample-and-hold  
0: Control bit ADC12SC triggers sample-and-hold followed by the A/D conversion.  
1: The trigger signal for sample-and-hold and conversion comes from Timer\_A3.EQU1.  
2: The trigger signal for sample-and-hold and conversion comes from Timer\_B.EQU0.  
3: The trigger signal for sample-and-hold and conversion comes from Timer\_B.EQU1.
- CStartAdd  
01A2h, bit12 to bit15  
Conversion start address CstartAdd is used to define which ADC12 control memory is used to start a (first) conversion. The value of CstartAdd ranges from 0 to 0Fh, corresponding to ADC12MEM0 to ADC12MEM15 and the associated control registers ADC12MCTL0 to ADC12MCTL15.

PRODUCT PREVIEW

### control register ADC12MCTLx and conversion memory ADC12MEMx

All control bits are reset during POR. POR is active after application of  $V_{CC}$ , or after a reset condition is applied to pin RST/NMI. Control registers ADC12MCTL.x can be modified only if enable conversion control bit ENC is reset. Any instruction that writes to an ADC12MCTLx register while the ENC bit is reset has no effect. A more detailed description of the control bit functions is found in the ADC12 module description (in the *MSP430x1xx User's Guide*).

There are sixteen ADC12MCTLx 8-bit memory control registers and sixteen ADC12MEMx 16-bit registers. Each of the memory control registers is associated with one ADC12MEMx register; for example, ADC12MEM0 is associated with ADC12MCTL0, ADC12MEM1, is associated with ADC12MCTL1, etc.

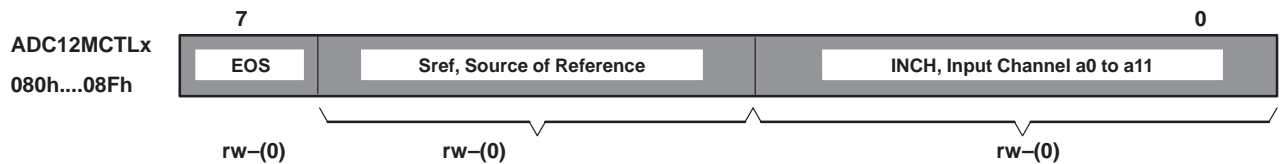

The control register bits are used to select the analog channel, the reference voltage sources for  $V_{R+}$  and  $V_{R-}$ , and a control signal which marks the last channel in a group of channels. The sixteen 16-bit registers ADC12MEMx are used to hold the conversion results.

The following illustration shows the conversion-result registers ADC12MEM0 to ADC12MEM15:

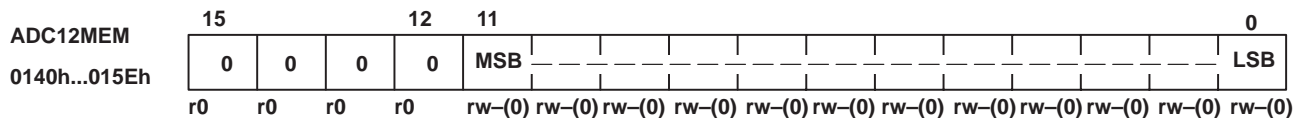

ADC12MEM0 to ADC12MEM15  
0140h, bit0, The 12 bits of the conversion result are stored in 16 control registers ADC12MEM0 to ADC12MEM15.  
015Eh, bit15 The 12 bits are right-justified and the upper four bits are always read as 0.

### ADC12 interrupt flags ADC12IFG.x and enable registers ADC12IEN.x

There are 16 ADC12IFG.x interrupt flags, 16 ADC12IE.x interrupt-enable bits, and one interrupt-vector word. The 16 interrupt flags and enable bits are associated with the 16 ADC12MEMx registers. For example, register ADC12MEM0, interrupt flag ADC12IFG.0, and interrupt-enable bit ADC12IE.0 form one conversion-result block.

ADC12IFG.0 has the highest priority and ADC12IFG.15 has the lowest priority.

All interrupt flags and interrupt-enable bits are reset during POR. POR is active after application of  $V_{CC}$  or after a reset condition is applied to the RST/NMI pin.

### ADC12 interrupt vector register

The 12-bit ADC has one interrupt vector for the overflow flag, the timing overflow flag, and sixteen interrupt flags. This vector indicates that a conversion result is stored into registers ADC12MEMx. Handling of the 18 flags is assisted by the interrupt-vector word. The 16-bit vector word ADC12IV indicates the highest pending interrupt. The interrupt-vector word is used to add an offset to the program counter so that the interrupt-handler software continues at the corresponding program location according to the interrupt event. This simplifies the interrupt-handler operation and assigns each interrupt event the same five-cycle overhead.

# MSP430x13x, MSP430x14x MIXED SIGNAL MICROCONTROLLER

SLAS272A – JULY 2000 – REVISED JULY 2000

## peripheral file map

PERIPHERALS WITH WORD ACCESS			
<b>Watchdog</b>	Watchdog Timer control	WDTCTL	0120h
<b>Timer_B7</b> Timer_B3 (see Note 9)	Timer_B interrupt vector	TBIV	011Eh
	Timer_B control	TBCTL	0180h
	Capture/compare control 0	CCTL0	0182h
	Capture/compare control 1	CCTL1	0184h
	Capture/compare control 2	CCTL2	0186h
	Capture/compare control 3	CCTL3	0188h
	Capture/compare control 4	CCTL4	018Ah
	Capture/compare control 5	CCTL5	018Ch
	Capture/compare control 6	CCTL6	018Eh
	Timer_B register	TBR	0190h
	Capture/compare register 0	CCR0	0192h
	Capture/compare register 1	CCR1	0194h
	Capture/compare register 2	CCR2	0196h
	Capture/compare register 3	CCR3	0198h
	Capture/compare register 4	CCR4	019Ah
	Capture/compare register 5	CCR5	019Ch
Capture/compare register 6	CCR6	019Eh	
<b>Timer_A3</b>	Timer_A interrupt vector	TAIV	012Eh
	Timer_A control	TACTL	0160h
	Capture/compare control 0	CCTL0	0162h
	Capture/compare control 1	CCTL1	0164h
	Capture/compare control 2	CCTL2	0166h
	Reserved		0168h
	Reserved		016Ah
	Reserved		016Ch
	Reserved		016Eh
	Timer_A register	TAR	0170h
	Capture/compare register 0	CCR0	0172h
	Capture/compare register 1	CCR1	0174h
	Capture/compare register 2	CCR2	0176h
	Reserved		0178h
	Reserved		017Ah
	Reserved		017Ch
Reserved		017Eh	
<b>Multiply</b> In MSP430x14x only	Sum extend	SumExt	013Eh
	Result high word	ResHi	013Ch
	Result low word	ResLo	013Ah
	Second operand	OP_2	0138h
	Multiply signed +accumulate/operand1	MACS	0136h
	Multiply+accumulate/operand1	MAC	0134h
	Multiply signed/operand1	MPYS	0132h
	Multiply unsigned/operand1	MPY	0130h

NOTE 10: Timer\_B7 in MSP430x14x family has 7 CCR, Timer\_B3 in MSP430x13x family has 3 CCR.

PRODUCT PREVIEW

# MSP430x13x, MSP430x14x MIXED SIGNAL MICROCONTROLLER

SLAS272A – JULY 2000 – REVISED JULY 2000

## peripheral file map (continued)

PERIPHERALS WITH WORD ACCESS (CONTINUED)			
<b>Flash</b>	Flash control 3	FCTL3	012Ch
	Flash control 2	FCTL2	012Ah
	Flash control 1	FCTL1	0128h
<b>ADC12</b> See also <i>Peripherals with Byte Access</i>	Conversion memory 15	ADC12MEM15	015Eh
	Conversion memory 14	ADC12MEM14	015Ch
	Conversion memory 13	ADC12MEM13	015Ah
	Conversion memory 12	ADC12MEM12	0158h
	Conversion memory 11	ADC12MEM11	0156h
	Conversion memory 10	ADC12MEM10	0154h
	Conversion memory 9	ADC12MEM9	0152h
	Conversion memory 8	ADC12MEM8	0150h
	Conversion memory 7	ADC12MEM7	014Eh
	Conversion memory 6	ADC12MEM6	014Ch
	Conversion memory 5	ADC12MEM5	014Ah
	Conversion memory 4	ADC12MEM4	0148h
	Conversion memory 3	ADC12MEM3	0146h
	Conversion memory 2	ADC12MEM2	0144h
	Conversion memory 1	ADC12MEM1	0142h
	Conversion memory 0	ADC12MEM0	0140h
	Interrupt-vector-word register	ADC12IV	01A8h
	Inerrupt-enable register	ADC12IE	01A6h
	Inerrupt-flag register	ADC12IFG	01A4h
Control register 1	ADC12CTL1	01A2h	
Control register 0	ADC12CTL0	01A0h	
<b>ADC12</b>	ADC memory-control register15	ADC12MCTL15	08Fh
	ADC memory-control register14	ADC12MCTL14	08Eh
	ADC memory-control register13	ADC12MCTL13	08Dh
	ADC memory-control register12	ADC12MCTL12	08Ch
	ADC memory-control register11	ADC12MCTL11	08Bh
	ADC memory-control register10	ADC12MCTL10	08Ah
	ADC memory-control register9	ADC12MCTL9	089h
	ADC memory-control register8	ADC12MCTL8	088h
	ADC memory-control register7	ADC12MCTL7	087h
	ADC memory-control register6	ADC12MCTL6	086h
	ADC memory-control register5	ADC12MCTL5	085h
	ADC memory-control register4	ADC12MCTL4	084h
	ADC memory-control register3	ADC12MCTL3	083h
	ADC memory-control register2	ADC12MCTL2	082h
	ADC memory-control register1	ADC12MCTL1	081h
	ADC memory-control register0	ADC12MCTL0	080h

PRODUCT PREVIEW

# MSP430x13x, MSP430x14x MIXED SIGNAL MICROCONTROLLER

SLAS272A – JULY 2000 – REVISED JULY 2000

## peripheral file map (continued)

PERIPHERALS WITH BYTE ACCESS			
<b>UART1</b> (Only in 'x14x)	Transmit buffer	UTXBUF.1	07Fh
	Receive buffer	URXBUF.1	07Eh
	Baud rate	UBR1.1	07Dh
	Baud rate	UBR0.1	07Ch
	Modulation control	UMCTL.1	07Bh
	Receive control	URCTL.1	07Ah
	Transmit control	UTCTL.1	079h
	UART control	UCTL.1	078h
<b>UART0</b>	Transmit buffer	UTXBUF.0	077h
	Receive buffer	URXBUF.0	076h
	Baud rate	UBR1.0	075h
	Baud rate	UBR0.0	074h
	Modulation control	UMCTL.0	073h
	Receive control	URCTL.0	072h
	Transmit control	UTCTL.0	071h
	UART control	UCTL.0	070h
<b>Comparator_A</b>	Comp._A port disable	CAPD	05Bh
	Comp._A control2	CACTL2	05Ah
	Comp._A control1	CACTL1	059h
<b>System Clock</b>	Basic clock system control2	BCSCTL2	058h
	Basic clock system control1	BCSCTL1	057h
	DCO clock frequency control	DCOCTL	056h
<b>Port P6</b>	Port P6 selection	P6SEL	037h
	Port P6 direction	P6DIR	036h
	Port P6 output	P6OUT	035h
	Port P6 input	P6IN	034h
<b>Port P5</b>	Port P5 selection	P5SEL	033h
	Port P5 direction	P5DIR	032h
	Port P5 output	P5OUT	031h
	Port P5 input	P5IN	030h
<b>Port P4</b>	Port P4 selection	P4SEL	01Fh
	Port P4 direction	P4DIR	01Eh
	Port P4 output	P4OUT	01Dh
	Port P4 input	P4IN	01Ch
<b>Port P3</b>	Port P3 selection	P3SEL	01Bh
	Port P3 direction	P3DIR	01Ah
	Port P3 output	P3OUT	019h
	Port P3 input	P3IN	018h
<b>Port P2</b>	Port P2 selection	P2SEL	02Eh
	Port P2 interrupt enable	P2IE	02Dh
	Port P2 interrupt-edge select	P2IES	02Ch
	Port P2 interrupt flag	P2IFG	02Bh
	Port P2 direction	P2DIR	02Ah
	Port P2 output	P2OUT	029h
	Port P2 input	P2IN	028h

PRODUCT PREVIEW

# MSP430x13x, MSP430x14x MIXED SIGNAL MICROCONTROLLER

SLAS272A – JULY 2000 – REVISED JULY 2000

## peripheral file map (continued)

PERIPHERALS WITH BYTE ACCESS			
<b>Port P1</b>	Port P1 selection	P1SEL	026h
	Port P1 interrupt enable	P1IE	025h
	Port P1 interrupt-edge select	P1IES	024h
	Port P1 interrupt flag	P1IFG	023h
	Port P1 direction	P1DIR	022h
	Port P1 output	P1OUT	021h
	Port P1 input	P1IN	020h
<b>Special Functions</b>	SFR module enable 2	ME2	005h
	SFR module enable 1	ME1	004h
	SFR interrupt flag2	IFG2	003h
	SFR interrupt flag1	IFG1	002h
	SFR interrupt enable2	IE2	001h
	SFR interrupt enable1	IE1	000h

## absolute maximum ratings over operating free-air temperature (unless otherwise noted)†

Voltage applied at $V_{CC}$ to $V_{SS}$ .....	-0.3 V to + 4.1 V
Voltage applied to any pin (referenced to $V_{SS}$ ) .....	-0.3 V to $V_{CC}+0.3$ V
Diode current at any device terminal . . . . .	$\pm 2$ mA
Storage temperature (unprogrammed device) .....	-55°C to 150°C
Storage Temperature (programmed device) .....	-40°C to 85°C

† Stresses beyond those listed under “absolute maximum ratings” may cause permanent damage to the device. These are stress ratings only, and functional operation of the device at these or any other conditions beyond those indicated under “recommended operating conditions” is not implied. Exposure to absolute-maximum-rated conditions for extended periods may affect device reliability.

NOTE: All voltages referenced to  $V_{SS}$ .

PRODUCT PREVIEW

# MSP430x13x, MSP430x14x MIXED SIGNAL MICROCONTROLLER

SLAS272A – JULY 2000 – REVISED JULY 2000

## recommended operating conditions

PARAMETER		MIN	NOM	MAX	UNITS
Supply voltage during program execution, $V_{CC}$ ( $AV_{CC} = DV_{CC} = V_{CC}$ )		1.8		3.6	V
Supply voltage during flash memory programming, $V_{CC}$ ( $AV_{CC} = DV_{CC} = V_{CC}$ )		2.7		3.6	V
Supply voltage, $V_{SS}$		0.0		0.0	V
Operating free-air temperature range, $T_A$		-40		85	°C
LFXT1 crystal frequency, $f_{(LFXT1)}$ (see Notes 10, 11)	LF selected, XTS=0 Watch crystal		32768		Hz
	XT1 selected, XTS=1 Ceramic resonator	450		8000	kHz
	XT1 selected, XTS=1 Crystal	1000		8000	kHz
XT2 crystal frequency, $f_{(XT2)}$	Ceramic resonator	450		8000	kHz
	Crystal	1000		8000	
Processor frequency (signal MCLK), $f_{(System)}$	$V_{CC} = 2.2$ V	DC		5	MHz
	$V_{CC} = 3.6$ V	DC		8	
Flash-timing-generator frequency, $f_{(FTG)}$		257		476	kHz
Cumulative program time, $t_{(CPT)}$ (see Note 12)				3	ms
Low-level input voltage (TCK, TMS, TDI, RST/NMI), $V_{IL}$ (excluding $X_{in}$ , $X_{out}$ )		$V_{CC} = 2.2$ V/3 V	$V_{SS}$	$V_{SS} + 0.6$	V
High-level input voltage (TCK, TMS, TDI, RST/NMI), $V_{IH}$ (excluding $X_{in}$ , $X_{out}$ )		$V_{CC} = 2.2$ V/3 V	$0.8V_{CC}$	$V_{CC}$	V
Input levels at $X_{in}$ and $X_{out}$	$V_{IL}(X_{in}, X_{out})$	$V_{CC} = 2.2$ V/3 V	$V_{SS}$	$0.2 \times V_{SS}$	V
	$V_{IH}(X_{in}, X_{out})$		$0.8 \times V_{CC}$	$V_{CC}$	

- NOTES: 11. In LF mode, the LFXT1 oscillator requires a watch crystal and the LFXT1 oscillator requires a 5.1-M $\Omega$  resistor from XOUT to VSS when  $V_{CC} < 2.5$  V. In XT1-mode, the LFXT1 and XT2 oscillators accept a ceramic resonator or a crystal frequency of 4 MHz at  $V_{CC} \geq 2.2$  V. In XT1-mode, the LFXT1 and XT2 oscillators accept a ceramic resonator or an 8-MHz crystal frequency at  $V_{CC} \geq 2.8$  V.
12. In LF mode, the LFXT1 oscillator requires a watch crystal. LFXT1 accepts a ceramic resonator or a crystal in XT1 mode.
13. The cumulative program time must not be exceeded during a segment-write operation.

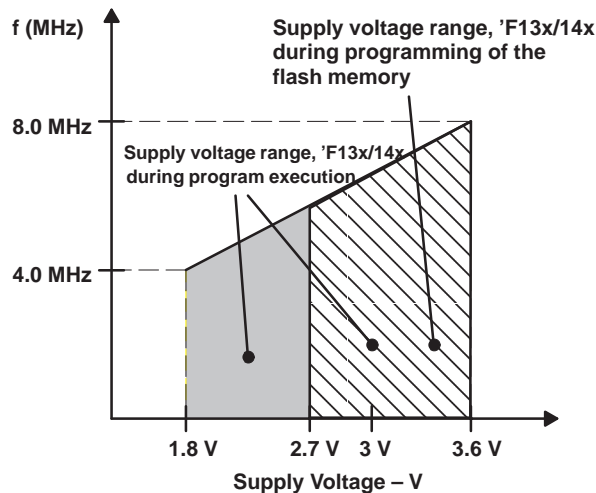

Figure 3. Frequency vs Supply Voltage, MSP430F13x or MSP430F14x

# MSP430x13x, MSP430x14x MIXED SIGNAL MICROCONTROLLER

SLAS272A – JULY 2000 – REVISED JULY 2000

**electrical characteristics over recommended operating free-air temperature (unless otherwise noted)**

**supply current into  $V_{CC}$  +  $DV_{CC}$  excluding external current,  $f_{(System)} = 1$  MHz**

PARAMETER		TEST CONDITIONS		MIN	NOM	MAX	UNIT		
$I_{(AM)}$	Active mode, $f_{(MCLK)} = f_{(SMCLK)} = 1$ MHz, $f_{(ACLK)} = 32,768$ Hz XTS=0, SELM=(0,1)	F135, F149	$T_A = -40^\circ\text{C}$ to $85^\circ\text{C}$	$V_{CC} = 2.2$ V		225	TBD	$\mu\text{A}$	
				$V_{CC} = 3$ V		340	TBD		
$I_{(AM)}$	Active mode, $f_{(MCLK)} = f_{(SMCLK)} = 4,096$ Hz, $f_{(ACLK)} = 4,096$ Hz XTS=0, SELM=(0,1) XTS=0, SELM=3	F135, F149	$T_A = -40^\circ\text{C}$ to $85^\circ\text{C}$	$V_{CC} = 2.2$ V		TBD	TBD	$\mu\text{A}$	
				$V_{CC} = 3$ V		TBD	TBD		
$I_{(LPM0)}$	Low-power mode, (LPM0)	F135, F149	$T_A = -40^\circ\text{C}$ to $85^\circ\text{C}$	$V_{CC} = 2.2$ V		65	TBD	$\mu\text{A}$	
				$V_{CC} = 3$ V		70	TBD		
$I_{(LPM2)}$	Low-power mode, (LPM2)		$T_A = -40^\circ\text{C}$ to $85^\circ\text{C}$	$V_{CC} = 2.2$ V		11	TBD	$\mu\text{A}$	
				$V_{CC} = 3$ V		17	TBD		
$I_{(LPM3)}$	Low-power mode, (LPM3) $f_{(MCLK)} = f_{(SMCLK)} = 0$ MHz, $f_{(ACLK)} = 32,768$ Hz, SCG0 = 1		$T_A = -40^\circ\text{C}$ to $85^\circ\text{C}$	$V_{CC} = 2.2$ V	$T_A = -40^\circ\text{C}$		1	TBD	$\mu\text{A}$
					$T_A = 25^\circ\text{C}$		0.9	TBD	
					$T_A = 85^\circ\text{C}$		2.7	TBD	
				$V_{CC} = 3$ V	$T_A = -40^\circ\text{C}$		2	TBD	$\mu\text{A}$
					$T_A = 25^\circ\text{C}$		1.9	TBD	
					$T_A = 85^\circ\text{C}$		3.9	TBD	
$I_{(LPM4)}$	Low-power mode, (LPM4) $f_{(MCLK)} = 0$ MHz, $f_{(SMCLK)} = 0$ MHz, $F_{(ACLK)} = 0$ Hz, SCG0 = 1		$T_A = -40^\circ\text{C}$ to $85^\circ\text{C}$	$V_{CC} = 2.2$ V	$T_A = -40^\circ\text{C}$		0.1	TBD	$\mu\text{A}$
					$T_A = 25^\circ\text{C}$		0.1	TBD	
					$T_A = 85^\circ\text{C}$		1.6	TBD	
				$V_{CC} = 3$ V	$T_A = -40^\circ\text{C}$		0.1	TBD	$\mu\text{A}$
					$T_A = 25^\circ\text{C}$		0.1	TBD	
					$T_A = 85^\circ\text{C}$		1.9	TBD	

PRODUCT PREVIEW

# MSP430x13x, MSP430x14x MIXED SIGNAL MICROCONTROLLER

SLAS272A – JULY 2000 – REVISED JULY 2000

## electrical characteristics over recommended operating free-air temperature (unless otherwise noted) (continued)

Current consumption of active mode versus system frequency, F-version

$$I_{(AM)} = I_{(AM)} [1 \text{ MHz}] \times f(\text{System}) [\text{MHz}]$$

Current consumption of active mode versus supply voltage, F-version

$$I_{(AM)} = I_{(AM)} [3 \text{ V}] + 120 \mu\text{A/V} \times (V_{CC} - 3 \text{ V})$$

### SCHMITT-trigger inputs – Ports P1, P2, P3, P4, P5, and P6

PARAMETER		TEST CONDITIONS	MIN	TYP	MAX	UNIT
V <sub>IT+</sub>	Positive-going input threshold voltage	V <sub>CC</sub> = 2.2 V	1.1		1.3	V
		V <sub>CC</sub> = 3 V	1.5		1.8	
V <sub>IT-</sub>	Negative-going input threshold voltage	V <sub>CC</sub> = 2.2 V	0.4		0.9	V
		V <sub>CC</sub> = 3 V	0.90		1.2	
V <sub>I</sub> – V <sub>O</sub>	Input/output voltage differential, (hysteresis)	V <sub>CC</sub> = 2.2 V	0.3		1	V
		V <sub>CC</sub> = 3 V	0.5		1.4	

### standard inputs – RST/NMI; JTAG: TCK, TMS, TDI, TDO/TDI

PARAMETER		TEST CONDITIONS	MIN	TYP	MAX	UNIT
V <sub>IL</sub>	Low-level input voltage	V <sub>CC</sub> = 2.2 V / 3 V	V <sub>SS</sub>		V <sub>SS</sub> +0.6	V
V <sub>IH</sub>	High-level input voltage		0.8×V <sub>CC</sub>		V <sub>CC</sub>	V

### outputs – Port 1: P1.0 to P1.7; Port 2: P2.0 to P2.5 (see Note 13)

PARAMETER		TEST CONDITIONS	MIN	TYP	MAX	UNIT
V <sub>OH</sub>	High-level output voltage	I <sub>OH(max)</sub> = –1.5 mA, V <sub>CC</sub> = 2.2 V, See Note 14	V <sub>CC</sub> –0.25		V <sub>CC</sub>	V
		I <sub>OH(max)</sub> = –6 mA, V <sub>CC</sub> = 2.2 V, See Note 15	V <sub>CC</sub> –0.6		V <sub>CC</sub>	
		I <sub>OH(max)</sub> = –1.5 mA, V <sub>CC</sub> = 3 V, See Note 14	V <sub>CC</sub> –0.25		V <sub>CC</sub>	
		I <sub>OH(max)</sub> = –6 mA, V <sub>CC</sub> = 3 V, See Note 15	V <sub>CC</sub> –0.6		V <sub>CC</sub>	
V <sub>OL</sub>	Low-level output voltage	I <sub>OL(max)</sub> = 1.5 mA, V <sub>CC</sub> = 2.2 V, See Note 14	V <sub>SS</sub>		V <sub>SS</sub> +0.25	V
		I <sub>OL(max)</sub> = 6 mA, V <sub>CC</sub> = 2.2 V, See Note 15	V <sub>SS</sub>		V <sub>SS</sub> +0.6	
		I <sub>OL(max)</sub> = 1.5 mA, V <sub>CC</sub> = 3 V, See Note 14	V <sub>SS</sub>		V <sub>SS</sub> +0.25	
		I <sub>OL(max)</sub> = 6 mA, V <sub>CC</sub> = 3 V, See Note 15	V <sub>SS</sub>		V <sub>SS</sub> +0.6	

NOTES: 14. In LF mode, the LFXT1 oscillator requires a 5.1-MΩ resistor connected from XOUT to V<sub>SS</sub> when V<sub>CC</sub> ≤ 2.5V. All inputs are tied to 0 V or to V<sub>CC</sub>. Outputs do not source or sink any current. The current consumptions in LPM2, LPM3, and LPM4 are measured with active ACLK selected.

15. The maximum total current, I<sub>OH(max)</sub> and I<sub>OL(max)</sub>, for all outputs combined, should not exceed ±12 mA to satisfy the maximum specified voltage drop.

16. The maximum total current, I<sub>OH(max)</sub> and I<sub>OL(max)</sub>, for all outputs combined, should not exceed ±48 mA to satisfy the maximum specified voltage drop.

### input frequency – Ports P1 to P6

PARAMETER		TEST CONDITIONS	MIN	TYP	MAX	UNIT
f <sub>(IN)</sub>	t <sub>(h)</sub> = t <sub>(L)</sub>	V <sub>CC</sub> = 2.2 V			8	MHz
		V <sub>CC</sub> = 3 V			10	

PRODUCT PREVIEW

# MSP430x13x, MSP430x14x MIXED SIGNAL MICROCONTROLLER

SLAS272A – JULY 2000 – REVISED JULY 2000

electrical characteristics over recommended operating free-air temperature (unless otherwise noted) (continued)

capture timing \_ Timer\_A3: TA0, TA1, TA2; Timer\_B7: Tb0 to TB6

PARAMETER		TEST CONDITIONS	MIN	TYP	MAX	UNIT
$t_{(int)}$	Ports P2, P4: External trigger signal for the interrupt flag (see Notes 16 and 17)	$V_{CC} = 2.2\text{ V}/3\text{ V}$	1.5			Cycle
		$V_{CC} = 2.2\text{ V}$	62			ns
		$V_{CC} = 3\text{ V}$	50			

NOTES: 17. The external signal sets the interrupt flag every time  $t_{(int)}$  is met. It may be set even with trigger signals shorter than  $t_{(int)}$ . The conditions to set the flag must be met independently of this timing constraint.  $t_{(int)}$  is defined in MCLK cycles.  
18. The external signal needs additional timing because of the maximum input-frequency constraint.

output frequency

PARAMETER		TEST CONDITIONS		MIN	TYP	MAX	UNIT
$f_{TAx}$	TA0..2, TB0–TB6, Internal clock source, SMCLK signal applied (see Note 18)	$C_L = 20\text{ pF}$		DC		$f_{System}$	MHz
$f_{ACLK}$ , $f_{MCLK}$ , $f_{SMC}$	P5.6/ACLK, P5.4/MCLK, P5.5/SMCLK	$C_L = 20\text{ pF}$				$f_{System}$	
$t_{Xdc}$	Duty cycle of output frequency,	P2.0/ACLK $C_L = 20\text{ pF}$ , $V_{CC} = 2.2\text{ V} / 3\text{ V}$	$f_{ACLK} = f_{LFXT1} = f_{XT1}$	40%		60%	
			$f_{ACLK} = f_{LFXT1} = f_{LF}$	30%		70%	
			$f_{ACLK} = f_{LFXT1}/n$		50%		
		P1.4/SMCLK, $C_L = 20\text{ pF}$ , $V_{CC} = 2.2\text{ V} / 3\text{ V}$	$f_{SMCLK} = f_{LFXT1} = f_{XT1}$	40%		60%	
			$f_{SMCLK} = f_{LFXT1} = f_{LF}$	35%		65%	
			$f_{SMCLK} = f_{LFXT1}/n$	50%– 15 ns	50%	50%– 15 ns	
$f_{SMCLK} = f_{DCOCLK}$	50%– 15 ns	50%	50%– 15 ns				

NOTE 19: The limits of the system clock MCLK has to be met; the system (MCLK) frequency should not exceed the limits. MCLK and SMCLK frequencies can be different.

external interrupt timing

PARAMETER		TEST CONDITIONS	MIN	TYP	MAX	UNIT
$t_{(int)}$	Ports P1, P2: External trigger signal for the interrupt flag (see Notes 16 and 17)	$V_{CC} = 2.2\text{ V}/3\text{ V}$	1.5			Cycle
		$V_{CC} = 2.2\text{ V}$	62			ns
		$V_{CC} = 3\text{ V}$	50			

NOTES: 16 The external signal sets the interrupt flag every time  $t_{(int)}$  is met. It may be set even with trigger signals shorter than  $t_{(int)}$ . The conditions to set the flag must be met independently of this timing constraint.  $t_{(int)}$  is defined in MCLK cycles.  
17 The external signal needs additional timing because of the maximum input-frequency constraint.

wake-up LPM3

PARAMETER		TEST CONDITIONS		MIN	TYP	MAX	UNIT
$t_{(LPM3)}$	Delay time	$f = 1\text{ MHz}$	$V_{CC} = 2.2\text{ V}/3\text{ V}$			6	$\mu\text{s}$
		$f = 2\text{ MHz}$				6	
		$f = 3\text{ MHz}$				6	

PRODUCT PREVIEW

# MSP430x13x, MSP430x14x MIXED SIGNAL MICROCONTROLLER

SLAS272A – JULY 2000 – REVISED JULY 2000

## electrical characteristics over recommended operating free-air temperature (unless otherwise noted) (continued)

### leakage current (see Note 19)

PARAMETER		TEST CONDITIONS		MIN	TYP	MAX	UNIT
$I_{kg}(P1.x)$	Leakage current	Port P1	Port 1: $V(P1.x)$ (see Note 20)	$V_{CC} = 2.2 V/3 V$			nA
$I_{kg}(P2.x)$		Port P2	Port 2: $V(P2.3) V(P2.4)$ (see Note 20)				
$I_{kg}(P6.x)$		Port P6	Port 6: $V(P6.x)$ (see Note 20)				

NOTES: 20. The leakage current is measured with  $V_{SS}$  or  $V_{CC}$  applied to the corresponding pin(s), unless otherwise noted.

21. The port pin must be selected as input and there must be no optional pullup or pulldown resistor.

### RAM

PARAMETER	TEST CONDITIONS	MIN	TYP	MAX	UNIT
VRAMh	CPU HALTED (see Note 21)	1.6			V

NOTE 22: This parameter defines the minimum supply voltage when the data in program memory RAM remain unchanged. No program execution should take place during this supply voltage condition.

### Comparator\_A (see Note 23)

PARAMETER		TEST CONDITIONS		MIN	TYP	MAX	UNIT
$I_{(DD)}$		CAON=1, CARSEL=0, CAREF=0	$V_{CC} = 2.2 V$	25	40	$\mu A$	
			$V_{CC} = 3 V$	45	60		
$I_{(RefLadder/RefDiode)}$		CAON=1, CARSEL=0, CAREF=1/2/3, No load at P2.3/CA0/TA1 and P2.4/CA1/TA2	$V_{CC} = 2.2 V$	30	50	$\mu A$	
			$V_{CC} = 3 V$	45	71		
$V_{(IC)}$	Common-mode input voltage	CAON = 1	$V_{CC} = 2.2 V/3 V$	0	$V_{CC}-1$	V	
$V_{(Ref025)}$ See Figure 4	$\frac{\text{Voltage @ } 0.25 V_{CC} \text{ node}}{V_{CC}}$	PCA0=1, CARSEL=1, CAREF=1, No load at P2.3/CA0/TA1 and P2.4/CA1/TA2, See Figure 4	$V_{CC} = 2.2 V/3 V$	0.23	0.24	0.25	
$V_{(Ref050)}$ See Figure 4	$\frac{\text{Voltage @ } 0.5 V_{CC} \text{ node}}{V_{CC}}$	PCA0=1, CARSEL=1, CAREF=2, No load at P2.3/CA0/TA1 and P2.4/CA1/TA2, See Figure 4	$V_{CC} = 2.2 V/3 V$	0.47	0.48	0.5	
$V_{(RefVT)}$		PCA0=1, CARSEL=1, CAREF=3, No load at P2.3/CA0/TA1 and P2.4/CA1/TA2	$V_{CC} = 2.2 V$	430	550	645	mV
			$V_{CC} = 3 V$	450	565	660	
$V_{(offset)}$	Offset voltage	See Note 18	$V_{CC} = 2.2 V/3 V$	-30		30	mV
$V_{hys}$	Input hysteresis	CAON=1	$V_{CC} = 2.2 V/3 V$	0	0.7	1.4	mV
$t_{(response LH)}$		$T_A = 25^\circ C$ , Overdrive 10 mV, Without filter: CAF=0	$V_{CC} = 2.2 V$	160	210	300	ns
			$V_{CC} = 3 V$	90	150	200	
		$T_A = 25^\circ C$ , Overdrive 10 mV, With filter: CAF=1	$V_{CC} = 2.2 V$	1.6	1.9	3.4	$\mu s$
			$V_{CC} = 3 V$	1.1	1.5	2.6	
$t_{(response HL)}$		$T_A = 25^\circ C$ , Overdrive 10 mV, without filter: CAF=0	$V_{CC} = 2.2 V$	160	210	300	ns
			$V_{CC} = 3 V$	90	150	200	
		$T_A = 25^\circ C$ , Overdrive 10 mV, with filter: CAF=1	$V_{CC} = 2.2 V$	1.6	1.9	3.4	$\mu s$
			$V_{CC} = 3 V$	1.1	1.5	2.6	

NOTES: 23. The leakage current for the Comparator\_A terminals is identical to  $I_{kg}(P_{x.x})$  specification.

24. The input offset voltage can be cancelled by using the CAEX bit to invert the Comparator\_A inputs on successive measurements. The two successive measurements are then summed together.

PRODUCT PREVIEW

electrical characteristics over recommended operating free-air temperature (unless otherwise noted) (continued)

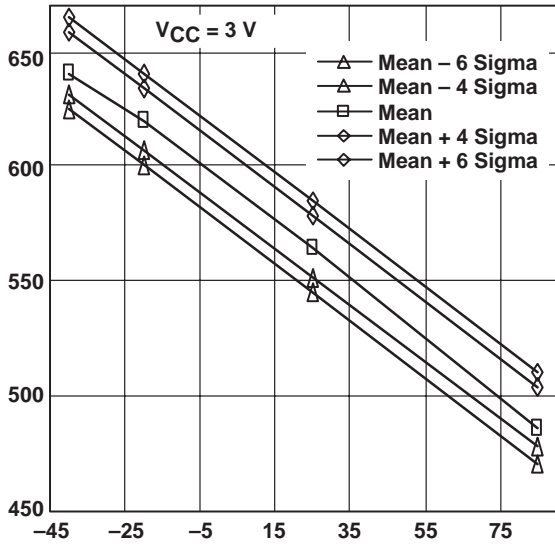

Figure 4.  $V_{(RefVT)}$  vs Temperature,  $V_{CC} = 3\text{ V}$

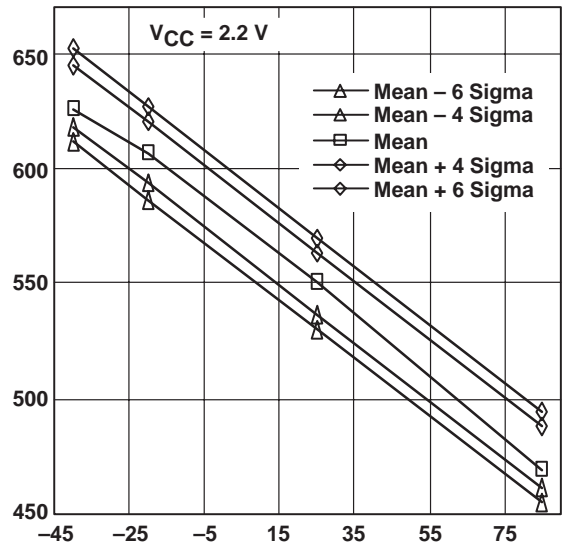

Figure 5.  $V_{(RefVT)}$  vs Temperature,  $V_{CC} = 2.2\text{ V}$

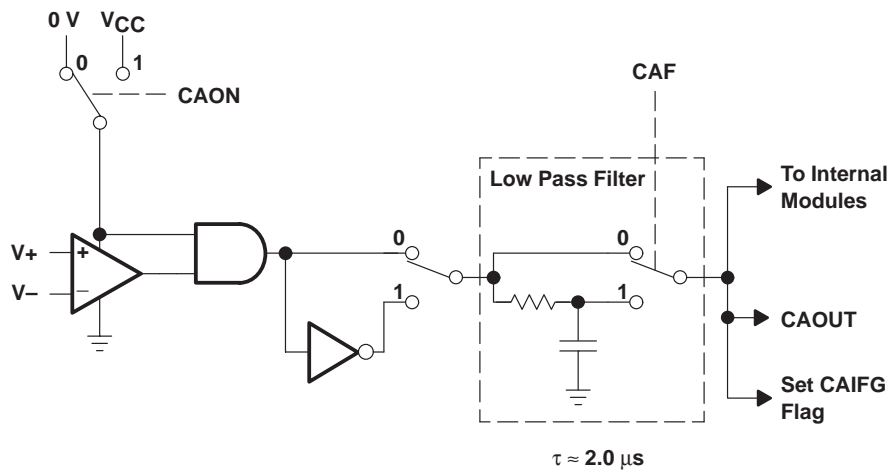

Figure 6. Block Diagram of Comparator\_A Module

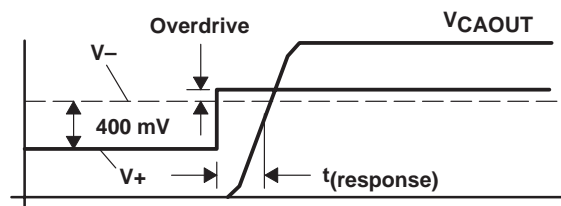

Figure 7. Overdrive Definition

# MSP430x13x, MSP430x14x MIXED SIGNAL MICROCONTROLLER

SLAS272A – JULY 2000 – REVISED JULY 2000

electrical characteristics over recommended operating free-air temperature (unless otherwise noted) (continued)

## POR

PARAMETER	CONDITIONS	V <sub>CC</sub>	MIN	NOM	MAX	UNIT
t(POR) Delay		2.2 V/3 V		150	250	μs
V(POR)	T <sub>A</sub> = -40°C		1.4		1.8	V
V(POR)	T <sub>A</sub> = +25°C		1.1		1.5	V
V(POR)	T <sub>A</sub> = +85°C		0.8		1.2	V
V(min)			0		0.4	V
t(Reset)	PUC/POR	Reset is accepted internally	2.2 V/3 V	2		μs

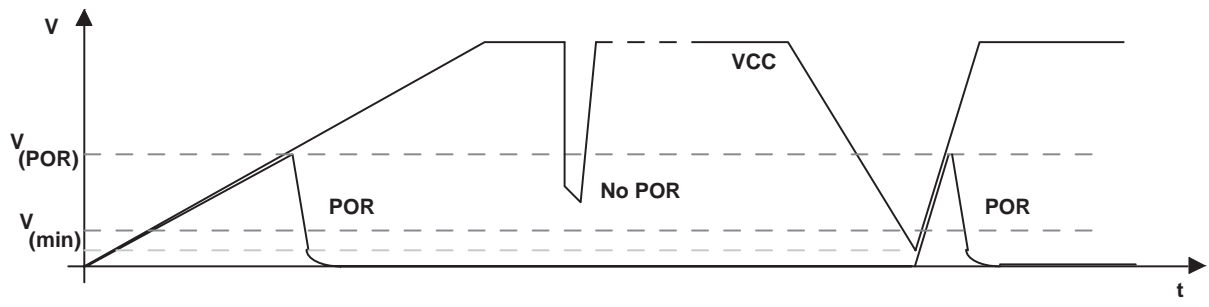

Figure 8. Power-On Reset (POR) vs Supply Voltage

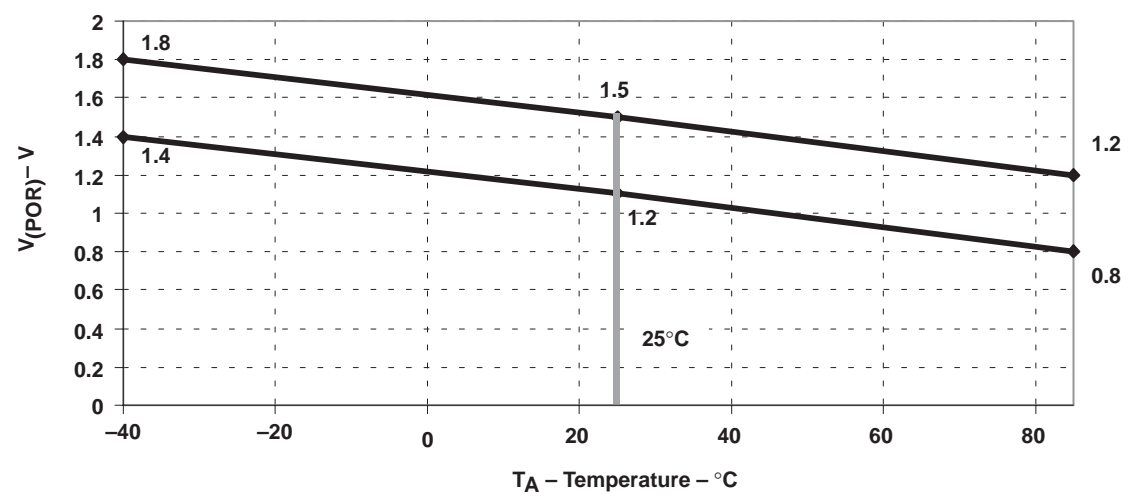

Figure 9. V(POR) vs Temperature

PRODUCT PREVIEW

# MSP430x13x, MSP430x14x MIXED SIGNAL MICROCONTROLLER

SLAS272A – JULY 2000 – REVISED JULY 2000

electrical characteristics over recommended operating free-air temperature (unless otherwise noted) (continued)

## DCO (see Note 25)

PARAMETER	TEST CONDITIONS	MIN	NOM	MAX	UNIT	
$f_{(DCO03)}$	$R_{sel} = 0, DCO = 3, MOD = 0, DCOR = 0, T_A = 25^\circ C$	$V_{CC} = 2.2 V$	0.08	0.12	0.15	MHz
		$V_{CC} = 3 V$	0.08	0.13	0.16	
$f_{(DCO13)}$	$R_{sel} = 1, DCO = 3, MOD = 0, DCOR = 0, T_A = 25^\circ C$	$V_{CC} = 2.2 V$	0.14	0.19	0.23	MHz
		$V_{CC} = 3 V$	0.14	0.18	0.22	
$f_{(DCO23)}$	$R_{sel} = 2, DCO = 3, MOD = 0, DCOR = 0, T_A = 25^\circ C$	$V_{CC} = 2.2 V$	0.22	0.30	0.36	MHz
		$V_{CC} = 3 V$	0.22	0.28	0.34	
$f_{(DCO33)}$	$R_{sel} = 3, DCO = 3, MOD = 0, DCOR = 0, T_A = 25^\circ C$	$V_{CC} = 2.2 V$	0.37	0.49	0.59	MHz
		$V_{CC} = 3 V$	0.37	0.47	0.56	
$f_{(DCO43)}$	$R_{sel} = 4, DCO = 3, MOD = 0, DCOR = 0, T_A = 25^\circ C$	$V_{CC} = 2.2 V$	0.61	0.77	0.93	MHz
		$V_{CC} = 3 V$	0.61	0.75	0.90	
$f_{(DCO53)}$	$R_{sel} = 5, DCO = 3, MOD = 0, DCOR = 0, T_A = 25^\circ C$	$V_{CC} = 2.2 V$	1	1.2	1.5	MHz
		$V_{CC} = 3 V$	1	1.3	1.5	
$f_{(DCO63)}$	$R_{sel} = 6, DCO = 3, MOD = 0, DCOR = 0, T_A = 25^\circ C$	$V_{CC} = 2.2 V$	1.6	1.9	2.2	MHz
		$V_{CC} = 3 V$	1.69	2.0	2.29	
$f_{(DCO73)}$	$R_{sel} = 7, DCO = 3, MOD = 0, DCOR = 0, T_A = 25^\circ C$	$V_{CC} = 2.2 V$	2.4	2.9	3.4	MHz
		$V_{CC} = 3 V$	2.7	3.2	3.65	
$f_{(DCO47)}$	$R_{sel} = 4, DCO = 7, MOD = 0, DCOR = 0, T_A = 25^\circ C$	$V_{CC} = 2.2 V/3 V$	$f_{DCO40} \times 1.7$	$f_{DCO40} \times 2.1$	$f_{DCO40} \times 2.5$	MHz
$S_{(Rsel)}$	$S_R = f_{Rsel+1} / f_{Rsel}$	$V_{CC} = 2.2 V/3 V$	1.35	1.65	2	
$S_{(DCO)}$	$S_{DCO} = f_{DCO+1} / f_{DCO}$	$V_{CC} = 2.2 V/3 V$	1.07	1.12	1.16	
$D_t$	Temperature drift, $R_{sel} = 4, DCO = 3, MOD = 0$ (see Note 26)	$V_{CC} = 2.2 V$	-0.31	-0.36	-0.40	%/ $^\circ C$
		$V_{CC} = 3 V$	-0.33	-0.38	-0.43	
$D_V$	Drift with $V_{CC}$ variation, $R_{sel} = 4, DCO = 3, MOD = 0$ (see Note 26)	$V_{CC} = 2.2 V/3 V$	0	5	10	%/V

NOTES: 25. The DCO frequency may not exceed the maximum system frequency defined by parameter Processor frequency,  $f_{(System)}$ .  
26. This parameter is not production tested.

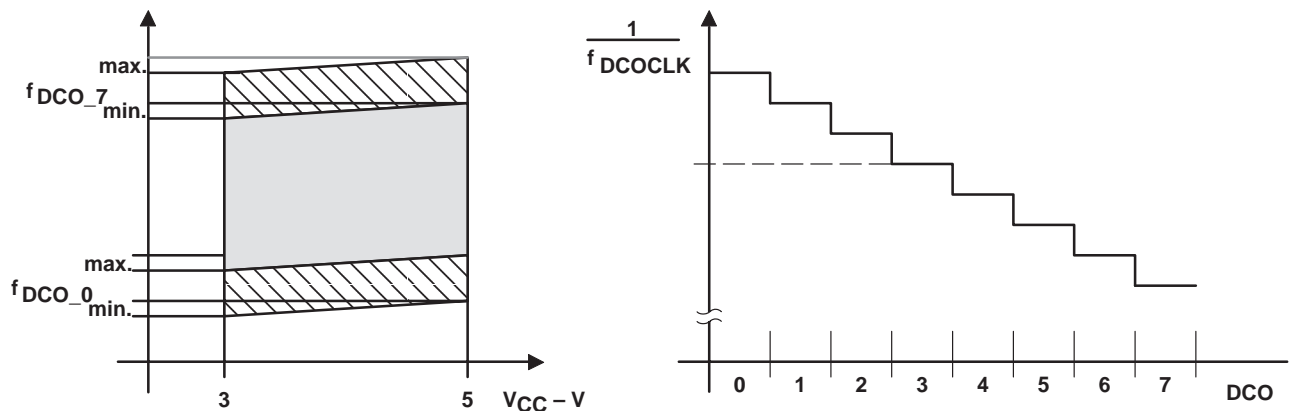

Figure 10. DCO Characteristics

PRODUCT PREVIEW

# MSP430x13x, MSP430x14x MIXED SIGNAL MICROCONTROLLER

SLAS272A – JULY 2000 – REVISED JULY 2000

## electrical characteristics over recommended operating free-air temperature (unless otherwise noted) (continued)

### main DCO characteristics

- Individual devices have a minimum and maximum operation frequency. The specified parameters for fDCOx0 to fDCOx7 are valid for all devices.
- All ranges selected by Rsel(n) overlap with Rsel(n+1): Rsel0 overlaps with Rsel1, ... Rsel6 overlaps with Rsel7.
- DCO control bits DCO0, DCO1, and DCO2 have a step size as defined by parameter SDCO.
- Modulation control bits MOD0 to MOD4 select how often fDCO+1 is used within the period of 32 DCOCLK cycles. The frequency f(DCO) is used for the remaining cycles. The frequency is an average equal to  $f(\text{DCO}) \times (2^{\text{MOD}/32})$ .

### crystal oscillator, LFXT1 oscillator (see Note 27)

PARAMETER	TEST CONDITIONS	MIN	NOM	MAX	UNIT
XCIN Integrated input capacitance	XTS=0; LF oscillator selected VCC = 2.2 V/3 V		12		pF
	XTS=1; XT1 oscillator selected VCC = 2.2 V/3 V		2		
XCOUT Integrated output capacitance	XTS=0; LF oscillator selected VCC = 2.2 V/3 V		12		pF
	XTS=1; XT1 oscillator selected VCC = 2.2 V/3 V		2		
XINL Input levels at XIN, XOUT	VCC = 2.2 V/3 V	VSS		0.2 × VCC	V
XINH	VCC = 2.2 V/3 V	0.8 × VCC		VCC	V

NOTE 27: The oscillator needs capacitors at both terminals, with values specified by the crystal manufacturer.

### crystal oscillator, XT2 oscillator (see Note 27)

PARAMETER	TEST CONDITIONS	MIN	NOM	MAX	UNIT
XCIN Integrated input capacitance	VCC = 2.2 V/3 V		2		pF
XCOUT Integrated output capacitance	VCC = 2.2 V/3 V		2		pF
XINL Input levels at XIN, XOUT	VCC = 2.2 V/3 V	VSS		0.2 × VCC	V
XINH	VCC = 2.2 V/3 V	0.8 × VCC		VCC	V

NOTE 26: The oscillator needs capacitors at both terminals, with values specified by the crystal manufacturer.

### USART (see Note 28)

PARAMETER	TEST CONDITIONS	MIN	NOM	MAX	UNIT
t(τ) USART: deglitch time	VCC = 2.2 V	0.6		2.6	μs
	VCC = 2.2 V	0.3		1.4	

NOTE 28: The signal applied to the USART receive signal/terminal (URXD) should meet the timing requirements of t(τ) to ensure that the URXS flip-flop is set. The URXS flip-flop is set with negative pulses meeting the minimum-timing condition of t(τ). The operating conditions to set the flag must be met independently from this timing constraint. The deglitch circuitry is active only on negative transitions on the URXD line.

PRODUCT PREVIEW

# MSP430x13x, MSP430x14x MIXED SIGNAL MICROCONTROLLER

SLAS272A – JULY 2000 – REVISED JULY 2000

**electrical characteristics over recommended operating free-air temperature (unless otherwise noted) (continued)**

**12-bit ADC, power supply and input range conditions (see Note 29)**

PARAMETER		TEST CONDITIONS		MIN	NOM	MAX	UNIT
$V_{CC}$	Analog supply voltage	$V_{CC}$ and $DV_{CC}$ are connected together $V_{SS}$ and $DV_{SS}$ are connected together $V_{(AVSS)} = V_{(DVSS)} = 0\text{ V}$		1.8		3.6	V
$V_{REF+}$	Positive built-in reference voltage output	$2.5\text{ V} = 1$ for 2.5 V built-in reference	3 V	2.4	2.5	2.6	V
		$2.5\text{ V} = 0$ for 1.5 V built-in reference $I_{V(REF)+} \leq 1\text{ mA}$	2.2 V/3 V	1.44	1.5	1.56	
$I_{VREF+}$	Load current out of $V_{REF+}$ terminal		2.2 V	0.01		-0.5	mA
			3 V			-1	
$I_{L(VREF)+}$	Load-current regulation $V_{REF+}$ terminal	$I_{V(REF)+} = 500\text{ }\mu\text{A} \pm 100\text{ }\mu\text{A}$ Analog input voltage $\sim 0.75\text{ V}$ ; $2.5\text{ V} = 0$	2.2 V			$\pm 1$	LSB
			3 V			$\pm 1$	
		$I_{V(REF)+} = 500\text{ }\mu\text{A} \pm 100\text{ }\mu\text{A}$ Analog i/p voltage $\sim 1.25\text{ V}$ ; $2.5\text{ V} = 1$	3 V			$\pm 1$	LSB
$I_{DL(VREF)+}$	Load current regulation $V_{REF+}$ terminal	$I_{V(REF)+} = 100\text{ }\mu\text{A} \rightarrow 900\text{ }\mu\text{A}$ , $V_{CC} = 3\text{ V}$ , $a_x \sim 0.5 \times V_{REF+}$ Error of conversion result $\leq 1\text{ LSB}$	$C_{VREF+} = 0\text{ pF}$			600	ns
			$C_{VREF+} = 5\text{ }\mu\text{F}$			20	
$V_{eREF+}$	Positive external reference voltage input	$V_{eREF+} > V_{eREF-}/V_{eREF-}$ (see Note 30)		1.4		$V_{AVCC}$	V
$V_{REF-}/V_{eREF-}$	Negative external reference voltage input	$V_{eREF+} > V_{eREF-}/V_{eREF-}$ (see Note 31)		0		$V_{AVCC} - 1.4$	V
$(V_{eREF+} - V_{REF-}/V_{eREF-})$	Differential external reference voltage input	$V_{eREF+} > V_{eREF-}/V_{eREF-}$ (see Note 32)		1.4		$V_{AVCC}$	V
$V_{(P6.x/Ax)}$	Analog input voltage range (see Note 33)	All P6.0/A0 to P6.7/A7 terminals. Analog inputs selected in ADC12MCTLx register and P6Sel.x=1 $0 \leq x \leq 7$ ; $V_{(AVSS)} \leq V_{P6.x/Ax} \leq V_{(AVCC)}$		0		$V_{AVCC}$	V
$I_{ADC12}$	Operating supply current into $V_{CC}$ terminal (see Note 34)	$f_{ADC12CLK} = 5.0\text{ MHz}$ ADC12ON = 1, REFON = 0	2.2 V		0.65	1.3	mA
			3 V		0.8	1.6	
$I_{REF+}$	Operating supply current into $V_{CC}$ terminal (see Note 35)	$f_{ADC12CLK} = 5.0\text{ MHz}$ ADC12ON = 0, REFON = 1, $2.5\text{ V} = 1$	3 V		0.5	0.8	mA
$I_{REF+}$	Operating supply current (see Note 35)	$f_{ADC12CLK} = 5.0\text{ MHz}$ ADC12ON = 0, REFON = 1, $2.5\text{ V} = 0$	2.2 V		0.5	0.8	mA
			3 V		0.5	0.8	

- NOTES: 29. The leakage current is defined in the leakage current table with P6.x/Ax parameter.  
 30. The accuracy limits the minimum positive external reference voltage. Lower reference voltage levels may be applied with reduced accuracy requirements.  
 31. The accuracy limits the maximum negative external reference voltage. Higher reference voltage levels may be applied with reduced accuracy requirements.  
 32. The accuracy limits minimum external differential reference voltage. Lower differential reference voltage levels may be applied with reduced accuracy requirements.  
 33. The analog input voltage range must be within the selected reference voltage range  $V_{R+}$  to  $V_{R-}$  for valid conversion results.  
 34. The internal reference supply current is not included in current consumption parameter  $I_{ADC12}$ .  
 35. The internal reference current is supplied via terminal  $V_{CC}$ . Consumption is independent of the ADC12ON control bit, unless a conversion is active. The REFON bit enables to settle the built-in reference before starting an A/D conversion.

PRODUCT PREVIEW

# MSP430x13x, MSP430x14x MIXED SIGNAL MICROCONTROLLER

SLAS272A – JULY 2000 – REVISED JULY 2000

## electrical characteristics over recommended operating free-air temperature (unless otherwise noted) (continued)

### 12-bit ADC, built-in reference (see Note 39)

PARAMETER		TEST CONDITIONS	MIN	NOM	MAX	UNIT
$I_{VeREF+}$	Static input current (see Note 36)	$0V \leq V_{eREF+} \leq V_{AVCC}$		2.2 V/3 V		$\pm 1$ $\mu A$
$I_{VREF-}/V_{eREF-}$	Static input current (see Note 36)	$0V \leq V_{eREF-} \leq V_{AVCC}$		2.2 V/3 V		$\pm 1$ $\mu A$
$C_{VREF+}$	Capacitance at pin $V_{REF+}$ (see Note 37)	REFON =1, $0 mA \leq I_{VREF+} \leq I_{V(REF)+}(max)$		2.2 V/3 V		200 pF
$C_i$	Input capacitance (see Note 38)	REFON =1, $0 mA \leq I_{V(REF)+} \leq I_{V(REF)+}(max)$		2.2 V/3 V	5	$\mu F$
$Z_i$	Input MUX ON resistance(see Note 38)	Only one terminal can be selected at one time, P6.x/Ax		2.2 V	18	30 $\Omega$
		$0V \leq V_{Ax} \leq V_{AVCC}$		3 V		2000
$T_{REF+}$	Temperature coefficient of built-in reference	$I_{V(REF)+}$ is a constant in the range of $0 mA \leq I_{V(REF)+} \leq 1 mA$		2.2 V/3 V	20	1000 ppm/ $^{\circ}C$

NOTES: 36. The external reference is used during conversion to charge and discharge the capacitance array. The dynamic impedance should follow the recommendations on analog-source impedance to allow the charge to settle for 12-bit accuracy.

37. The internal buffer operational amplifier and the accuracy specifications require an external capacitor. The external capacitance has two limits: the first is a capacitance of 0 to the maximum data (pF-range), and the second is an external capacitor of greater than the minimum data ( $\mu F$ -range). The output amplifier operates in the safe area in both ranges.

38. The input capacitance is also the dynamic load for an external reference during conversion. The dynamic impedance of the reference supply should follow the recommendations on analog-source impedance to allow the charge to settle for 12-bit accuracy.

39. The voltage source on  $V_{eREF+}$  and  $V_{REF-}/V_{eREF-}$  needs to have low dynamic impedance for 12-bit accuracy. A minimum of 470 nF of the reference supply allows the charge to settle for the 12-bit accuracy.

PRODUCT PREVIEW

# MSP430x13x, MSP430x14x MIXED SIGNAL MICROCONTROLLER

SLAS272A – JULY 2000 – REVISED JULY 2000

electrical characteristics over recommended operating free-air temperature (unless otherwise noted) (continued)

## 12-bit ADC, timing parameters

PARAMETER		TEST CONDITIONS	MIN	NOM	MAX	UNIT
$t_{REF(ON)}$	Settle time of internal reference voltage (see Figure 11 and Note 40)	$I_{V(REF)+} = 0.5 \text{ mA}$ , $C_{V(REF)+} = 10 \mu\text{F}$ , $V_{REF+} = 1.5 \text{ V}$ , $V_{AVCC} = 2.2 \text{ V}$			17	ms
		$I_{V(REF)+} = 0.5 \text{ mA}$ , $0 \leq C_{V(REF)+} \leq 200 \text{ pF}$ , $V_{REF+} = 1.5 \text{ V}$ , $V_{AVCC} = 2.2 \text{ V}$	2.17		20	$\mu\text{s}$
$t_{CONVERT}$	Conversion time (see Figure 12)	$V_{AVCC(min)} \leq V_{AVCC} \leq V_{AVCC(max)}$ , $C_{V(REF)+} \geq 5 \mu\text{F}$ , Internal oscillator, $f_{OSC} = 4 \text{ MHz to } 6 \text{ MHz}$	2.17		3.6	$\mu\text{s}$
	Conversion time	$V_{AVCC(min)} \leq V_{AVCC} \leq V_{AVCC(max)}$ , External $f_{ADC12(CLK)}$ from ACLK or MCLK or SMCLK: $ADC12SSEL \neq 0$		$13 \times ADC12DIV \times$ $1/f_{ADC12(CLK)}$		$\mu\text{s}$
$t_{ADC12ON}$	Settle time of the ADC	$V_{AVCC(min)} \leq V_{AVCC} \leq V_{AVCC(max)}$ (see Note 41)			100	ns
$t_{Sample}$	Sampling time	$V_{AVCC(min)} \leq V_{AVCC} \leq V_{AVCC(max)}$ $R_{i(source)} = 400 \Omega$ , $Z_i = 1000 \Omega$ , $C_i = 30 \text{ pF}$ $\tau = [R_{i(source)} + Z_i] \times C_i$ (see Note 42)	3 V	1220		ns
			2.2 V	1400		

NOTES: 40. The condition is that the error in a conversion started after  $t_{REF(ON)}$  is less than  $\pm 0.5$  LSB. The settling time depends on the external capacitive load. The feedback of the binary-weighted capacitor array to the reference voltage requires a *large* external capacitor. Small external capacitors need greater conversion time (decreased  $f_{ADC12(CLK)}$ ).

41. The condition is that the error in a conversion started after  $t_{ADC12ON}$  is less than  $\pm 0.5$  LSB. The reference used is already settled.

42. Ten Tau ( $\tau$ ) are needed to get an error of less than  $\pm 0.5$  LSB.  $t_{Sample} = 10 \times (R_i + Z_i) + 800 \text{ ns}$

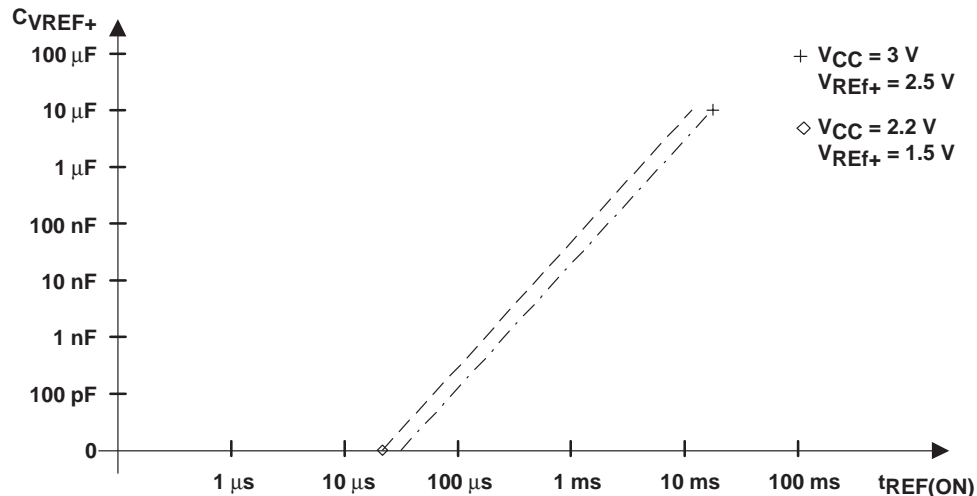

Figure 11. Maximum Settling Time of Internal Reference  $t_{REF(ON)}$  vs External Capacitor on  $V_{REF+}$

PRODUCT PREVIEW

# MSP430x13x, MSP430x14x MIXED SIGNAL MICROCONTROLLER

SLAS272A – JULY 2000 – REVISED JULY 2000

electrical characteristics over recommended operating free-air temperature (unless otherwise noted) (continued)

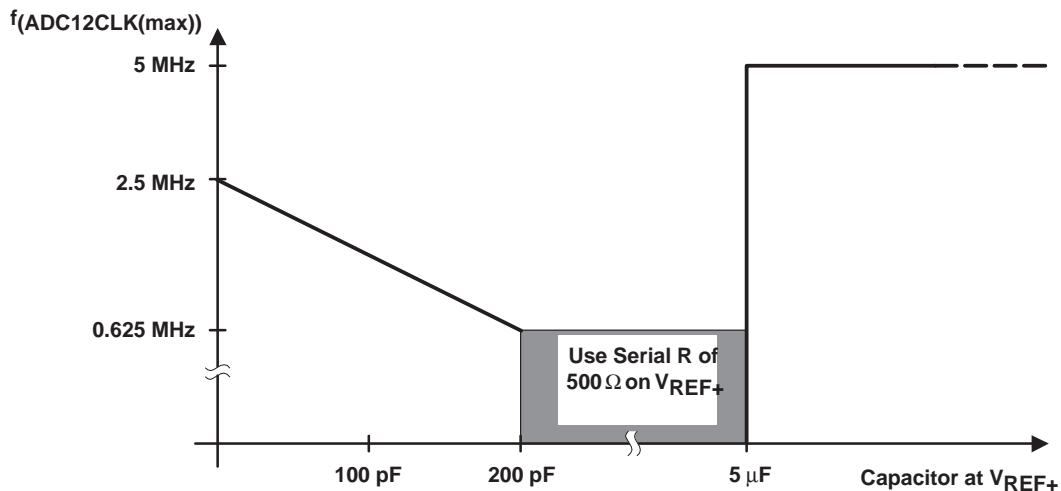

Figure 12. Maximum Frequency  $f_{ADC12(CLK)}$  vs External Capacitor on  $V_{REF+}$

## 12-bit ADC, linearity parameters

PARAMETER	TEST CONDITIONS	MIN	NOM	MAX	UNIT
$E_I$ Integral linearity error	$(V_{eREF+} - V_{REF-} - V_{eREF-})_{min} \leq (V_{eREF+} - V_{REF-} - V_{eREF-})$	2.2 V/3 V	$\pm 1$	TBD	LSB
$E_D$ Differential linearity error	$(V_{eREF+} - V_{REF-} - V_{eREF-})_{min} \leq (V_{eREF+} - V_{REF-} - V_{eREF-})$	2.2 V/3 V	$\pm 1$	TBD	LSB
$E_O$ Offset error	$(V_{eREF+} - V_{REF-} - V_{eREF-})_{min} \leq (V_{eREF+} - V_{REF-} - V_{eREF-})$ , Internal impedance of source $R_i < 100 \Omega$	2.2 V/3 V	$\pm 2$	TBD	LSB
$E_G$ Gain error	$(V_{eREF+} - V_{REF-} - V_{eREF-})_{min} \leq (V_{eREF+} - V_{REF-} - V_{eREF-})$	2.2 V/3 V	$\pm 1.1$	TBD	LSB
$E_T$ Total unadjusted error	$(V_{eREF+} - V_{REF-} - V_{eREF-})_{min} \leq (V_{eREF+} - V_{REF-} - V_{eREF-})$	2.2 V/3 V	$\pm 2$	TBD	LSB

PRODUCT PREVIEW

# MSP430x13x, MSP430x14x MIXED SIGNAL MICROCONTROLLER

SLAS272A – JULY 2000 – REVISED JULY 2000

**electrical characteristics over recommended operating free-air temperature (unless otherwise noted) (continued)**

## 12-bit ADC, temperature sensor and built-in Vmid

PARAMETER		TEST CONDITIONS	MIN	NOM	MAX	UNIT
I <sub>SENSOR</sub>	Operating supply current into AV <sub>CC</sub> terminal (see Note 43)	V <sub>REFON</sub> = 0, INCH = 0Ah, ADC12ON=NA., T <sub>A</sub> = 25°C	2.2 V	135	TBD	μA
			3 V	135	TBD	
V <sub>SENSOR</sub>		ADC12ON = 1, INCH = 0Ah, T <sub>A</sub> = 0°C	2.2 V	986	986±5%	mV
			3 V	986	986±5%	
T <sub>CSENSOR</sub>		ADC12ON = 1, INCH = 0Ah	2.2 V	3.55	3.55±3%	mV/°C
			3 V	3.55	3.55±3%	
t <sub>SENSOR(ON)</sub>	On-time if channel 10 is selected (see Note 44)	ADC12ON = 1, INCH = 0Ah, Error of conversion result ≤ 1 LSB	2.2 V		25	μs
			3 V		21	
I <sub>VMID</sub>	Current into divider at channel 11	ADC12ON = 1, INCH = 0Bh, (see Note 45)	2.2 V		NA	μA
			3 V		NA	
V <sub>MID</sub>	AV <sub>CC</sub> divider at channel 11	ADC12ON = 1, INCH = 0Bh, V <sub>MID</sub> is ~0.5 x V <sub>AVCC</sub>	2.2 V	0.9	0.90±0.04	V
			3 V	1.5	1.50±0.04	
t <sub>ON(VMID)</sub>	On-time if channel 11 is selected (see Note 46)	ADC12ON = 1, INCH = 0Bh, Error of conversion result ≤ 1 LSB	2.2 V		NA	ns
			3 V		NA	

NOTES: 43. The sensor current I<sub>SENSOR</sub> is consumed if (ADC12ON = 1 and V<sub>REFON</sub>=1), or (ADC12ON=1 AND INCH=0Ah and sample signal is high).

44. The typical equivalent impedance of the sensor is 51 kΩ. The sample time needed is the sensor-on time t<sub>SENSOR(ON)</sub>

45. No additional current is needed. The V<sub>MID</sub> is anyway used during conversion.

46. The on-time t<sub>ON(VMID)</sub> is identical to sampling time t<sub>Sample</sub>; no additional on time is needed.

## JTAG, program memory and fuse

PARAMETER		TEST CONDITIONS	V <sub>CC</sub>	MIN	NOM	MAX	UNIT
f <sub>(TCK)</sub>	JTAG/Test	TCK frequency	2.2 V	DC		5	MHz
			3 V	DC		10	
		Pullup resistors on TMS, TCK, TDI (see Note 47)	2.2 V/3 V	25	60	90	kΩ
V <sub>FB</sub>	JTAG/fuse (see Note 48)	Fuse-blow voltage, F versions (see Note 49)	2.2 V/3 V	6.0		7.0	V
I <sub>FB</sub>		Supply current on TDI with fuse blown				100	mA
		Time to blow the fuse				1	ms
I <sub>(DD-PGM)</sub>	F-versions only	Current from DV <sub>CC</sub> when programming is active	2.7 V/3.6 V		3	5	mA
I <sub>(DD-Erase)</sub>	F-versions only	Programming time, single pulse	2.7 V/3.6 V		3	5	mA
t <sub>(retention)</sub>	F-versions only	Write/erase cycles		10 <sup>4</sup>	10 <sup>5</sup>		cycles
		Data retention T <sub>J</sub> = 25°C		100			years

NOTES: 47. TMS, TDI, and TCK pull-up resistors are implemented in all F versions.

48. Once the fuse is blown, no further access to the MSP430 JTAG/test feature is possible. The JTAG block is switched to bypass mode.

49. The supply voltage to blow the fuse is applied to the TDI pin.

50. f<sub>(TCK)</sub> may be restricted to meet the timing requirements of the module selected. Duration of the program/erase cycle is determined by f<sub>(FTG)</sub> applied to the flash timing controller. It can be calculated as follows:

$$t(\text{word write}) = 33 \times 1/f(\text{FTG})$$

$$t(\text{segment write, byte 0}) = 30 \times 1/f(\text{FTG})$$

$$t(\text{segment write, byte 1 - 63}) = 20 \times 1/f(\text{FTG})$$

$$t(\text{mass erase}) = 5296 \times 1/f(\text{FTG})$$

$$t(\text{page erase}) = 4817 \times 1/f(\text{FTG})$$

PRODUCT PREVIEW

# MSP430x13x, MSP430x14x MIXED SIGNAL MICROCONTROLLER

SLAS272A – JULY 2000 – REVISED JULY 2000

## input/output schematic

port P1, P1.0 to P1.7, input/output with Schmitt-trigger

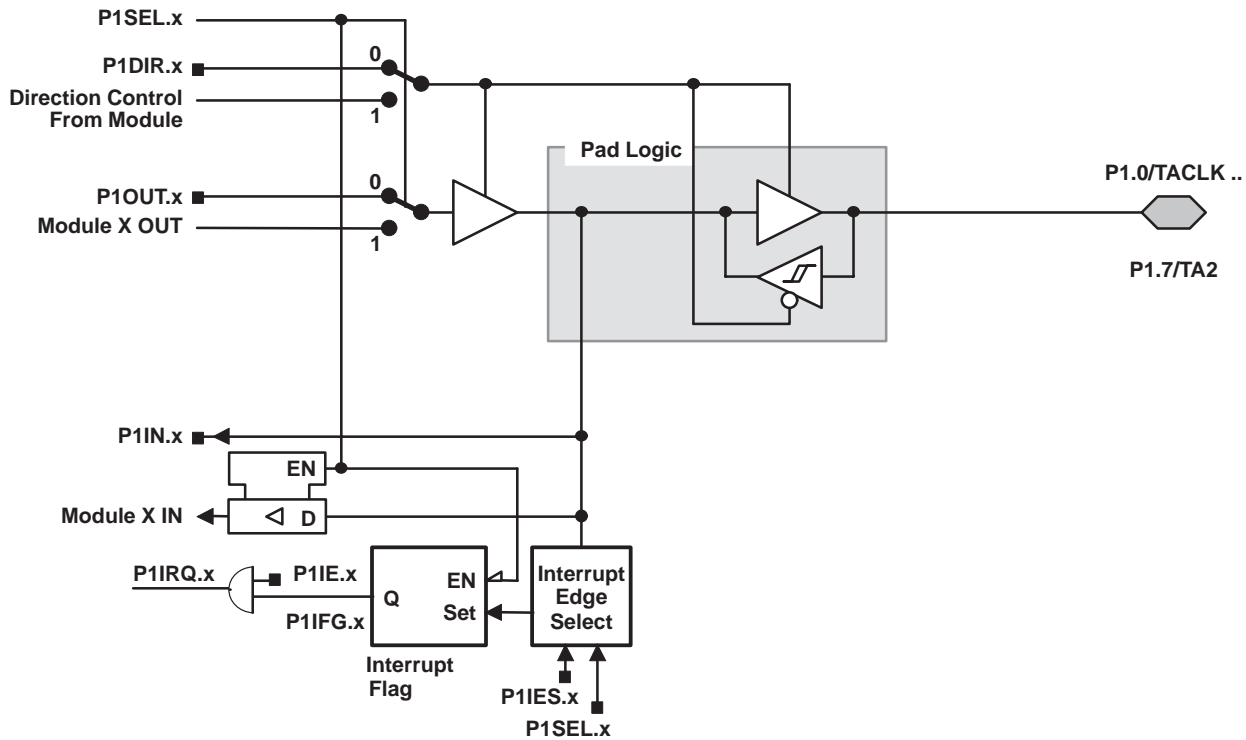

PnSel.x	PnDIR.x	Dir. CONTROL FROM MODULE	PnOUT.x	MODULE X OUT	PnIN.x	MODULE X IN	PnIE.x	PnIFG.x	PnIES.x
P1Sel.0	P1DIR.0	P1DIR.0	P1OUT.0	DV <sub>SS</sub>	P1IN.0	TACLK <sup>†</sup>	P1IE.0	P1IFG.0	P1IES.0
P1Sel.1	P1DIR.1	P1DIR.1	P1OUT.1	Out0 signal <sup>†</sup>	P1IN.1	CCI0A <sup>†</sup>	P1IE.1	P1IFG.1	P1IES.1
P1Sel.2	P1DIR.2	P1DIR.2	P1OUT.2	Out1 signal <sup>†</sup>	P1IN.2	CCI1A <sup>†</sup>	P1IE.2	P1IFG.2	P1IES.2
P1Sel.3	P1DIR.3	P1DIR.3	P1OUT.3	Out2 signal <sup>†</sup>	P1IN.3	CCI2A <sup>†</sup>	P1IE.3	P1IFG.3	P1IES.3
P1Sel.4	P1DIR.4	P1DIR.4	P1OUT.4	SMCLK	P1IN.4	unused	P1IE.4	P1IFG.4	P1IES.4
P1Sel.5	P1DIR.5	P1DIR.5	P1OUT.5	Out0 signal <sup>†</sup>	P1IN.5	unused	P1IE.5	P1IFG.5	P1IES.5
P1Sel.6	P1DIR.6	P1DIR.6	P1OUT.6	Out1 signal <sup>†</sup>	P1IN.6	unused	P1IE.6	P1IFG.6	P1IES.6
P1Sel.7	P1DIR.7	P1DIR.7	P1OUT.7	Out2 signal <sup>†</sup>	P1IN.7	unused	P1IE.7	P1IFG.7	P1IES.7

<sup>†</sup> Signal from or to Timer\_A

PRODUCT PREVIEW

# MSP430x13x, MSP430x14x MIXED SIGNAL MICROCONTROLLER

SLAS272A – JULY 2000 – REVISED JULY 2000

## input/output schematic (continued)

port P2, P2.0 to P2.2, P2.6, and P2.7 input/output with Schmitt-trigger

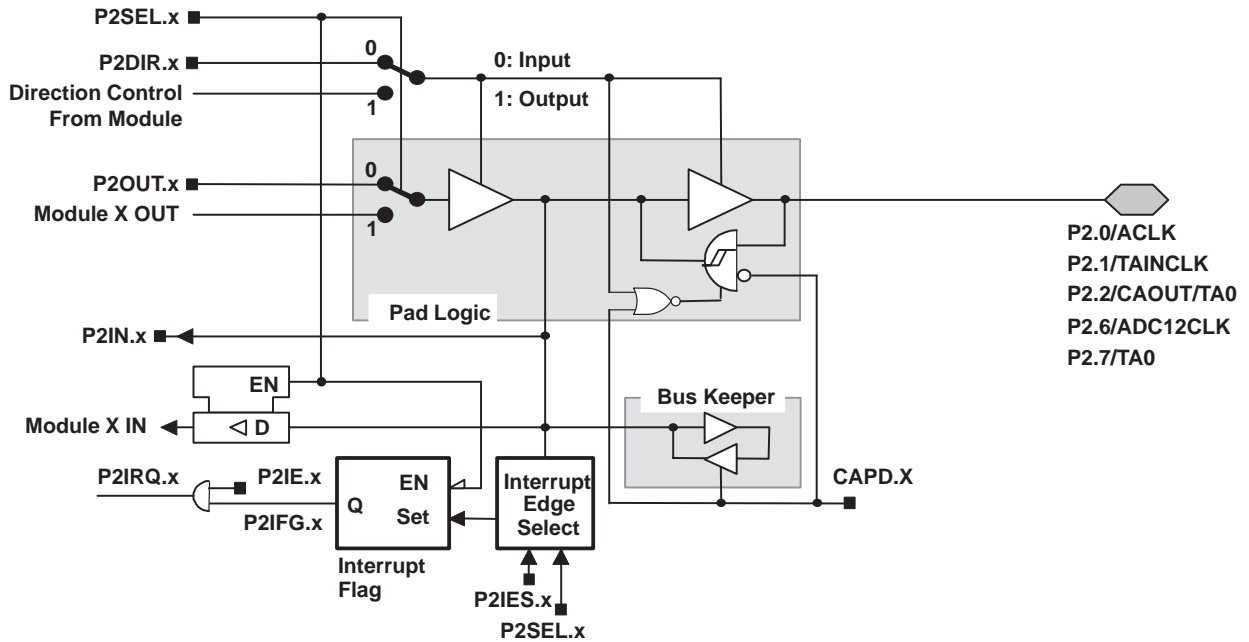

x: Bit Identifier 0 to 2, 6, and 7 for Port P2

PnSel.x	PnDIR.x	Dir. CONTROL FROM MODULE	PnOUT.x	MODULE X OUT	PnIN.x	MODULE X IN	PnIE.x	PnIFG.x	PnIES.x
P2Sel.0	P2DIR.0	P2DIR.0	P2OUT.0	ACLK	P2IN.0	unused	P2IE.0	P2IFG.0	P2IES.0
P2Sel.1	P2DIR.1	P2DIR.1	P2OUT.1	DV <sub>SS</sub>	P2IN.1	INCLK <sup>‡</sup>	P2IE.1	P2IFG.1	P2IES.1
P2Sel.2	P2DIR.2	P2DIR.2	P2OUT.2	CAOUT <sup>†</sup>	P2IN.2	CCI0B <sup>‡</sup>	P2IE.2	P2IFG.2	P2IES.2
P2Sel.6	P2DIR.6	P2DIR.6	P2OUT.6	ADC12CLK <sup>¶</sup>	P2IN.6	unused	P2IE.6	P2IFG.6	P2IES.6
P2Sel.7	P2DIR.7	P2DIR.7	P2OUT.7	Out0 signal <sup>§</sup>	P2IN.7	unused	P2IE.7	P2IFG.7	P2IES.7

<sup>†</sup> Signal from Comparator\_A

<sup>‡</sup> Signal to Timer\_A

<sup>§</sup> Signal from Timer\_A

<sup>¶</sup> ADC12CLK signal is output of the 12-bit ADC module

PRODUCT PREVIEW

# MSP430x13x, MSP430x14x MIXED SIGNAL MICROCONTROLLER

SLAS272A – JULY 2000 – REVISED JULY 2000

## input/output schematic (continued)

port P2, P2.3 to P2.4, input/output with Schmitt-trigger

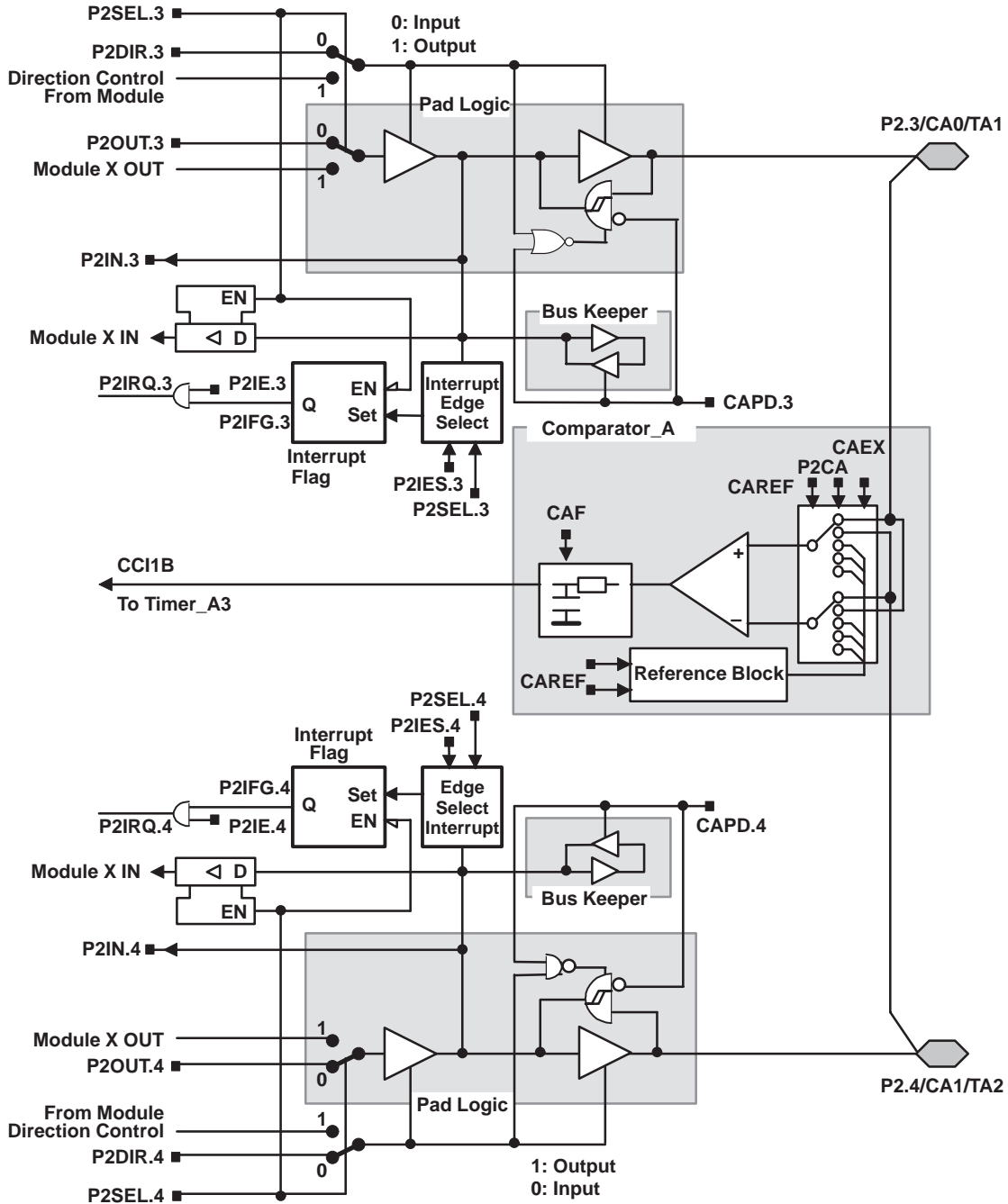

PRODUCT PREVIEW

PnSel.x	PnDIR.x	DIRECTION CONTROL FROM MODULE	PnOUT.x	MODULE X OUT	PnIN.x	MODULE X IN	PnIE.x	PnIFG.x	PnIES.x
P2Sel.3	P2DIR.3	P2DIR.3	P2OUT.3	Out1 signal†	P2IN.3	unused	P2IE.3	P2IFG.3	P2IES.3
P2Sel.4	P2DIR.4	P2DIR.4	P2OUT.4	Out2 signal†	P2IN.4	unused	P2IE.4	P2IFG.4	P2IES.4

† Signal from Timer\_A

# MSP430x13x, MSP430x14x MIXED SIGNAL MICROCONTROLLER

SLAS272A – JULY 2000 – REVISED JULY 2000

## input/output schematic (continued)

port P2, P2.5, input/output with Schmitt-trigger and  $R_{Osc}$  function for the basic clock module

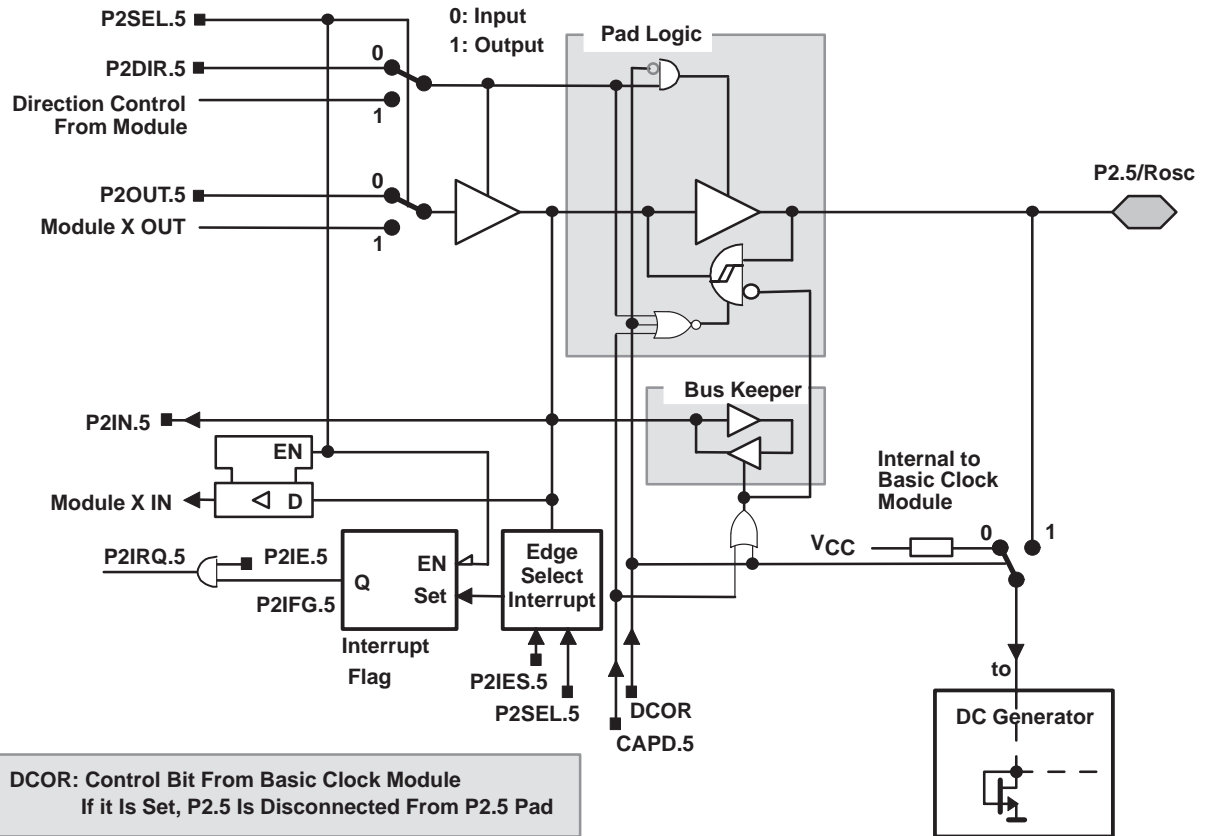

PnSel.x	PnDIR.x	DIRECTION CONTROL FROM MODULE	PnOUT.x	MODULE X OUT	PnIN.x	MODULE X IN	PnIE.x	PnIFG.x	PnIES.x
P2Sel.5	P2DIR.5	P2DIR.5	P2OUT.5	DV <sub>SS</sub>	P2IN.5	unused	P2IE.5	P2IFG.5	P2IES.5

PRODUCT PREVIEW

# MSP430x13x, MSP430x14x MIXED SIGNAL MICROCONTROLLER

SLAS272A – JULY 2000 – REVISED JULY 2000

## input/output schematic (continued)

port P3, P3.0 and P3.4 to P3.7, input/output with Schmitt-trigger

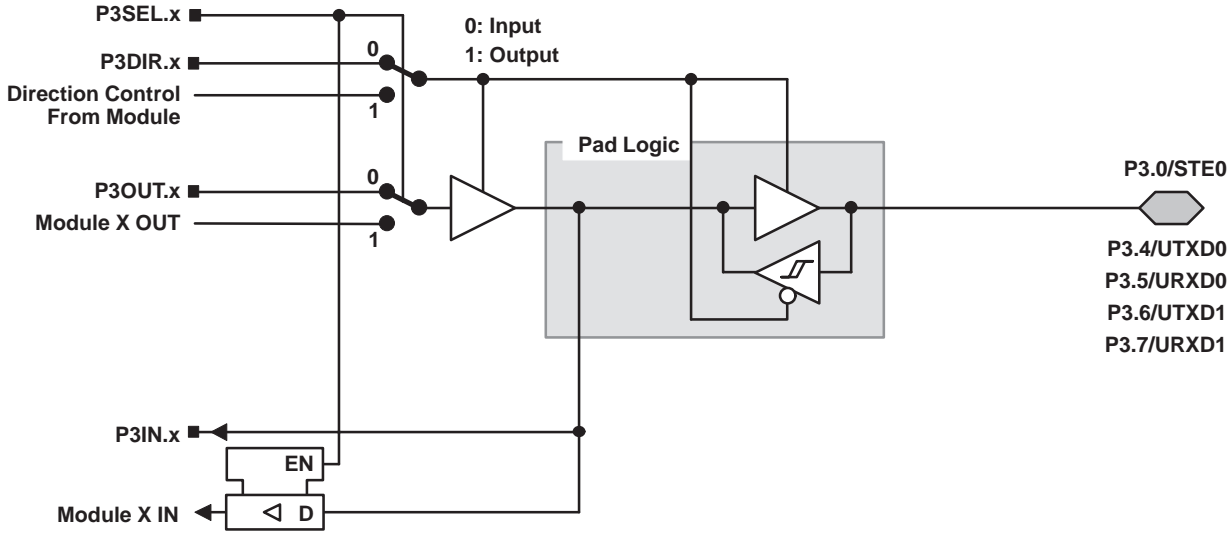

x: Bit Identifier, 0 and 4 to 7 for Port P3

PnSel.x	PnDIR.x	DIRECTION CONTROL FROM MODULE	PnOUT.x	MODULE X OUT	PnIN.x	MODULE X IN
P3Sel.0	P3DIR.0	DV <sub>SS</sub>	P3OUT.0	DV <sub>SS</sub>	P3IN.0	STE0
P3Sel.4	P3DIR.4	DV <sub>SS</sub>	P3OUT.4	UTXD0 <sup>†</sup>	P3IN.4	Unused
P3Sel.5	P3DIR.5	DV <sub>CC</sub>	P3OUT.5	DV <sub>SS</sub>	P3IN.5	URXD0 <sup>§</sup>
P3Sel.6	P3DIR.6	DV <sub>SS</sub>	P3OUT.6	UTXD1 <sup>‡</sup>	P3IN.6	Unused
P3Sel.7	P3DIR.7	DV <sub>CC</sub>	P3OUT.7	DV <sub>SS</sub>	P3IN.7	URXD1 <sup>¶</sup>

† Output from USART0 module  
 ‡ Output from USART1 module  
 § Input to USART0 module  
 ¶ Input to USART1 module

port P3, P3.1, input/output with Schmitt-trigger

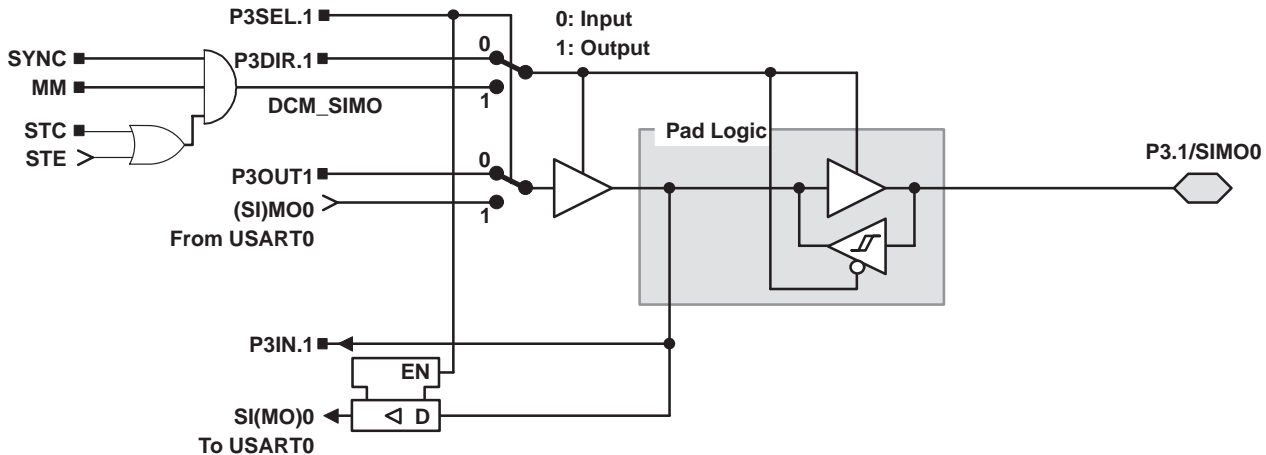

PRODUCT PREVIEW

input/output schematic (continued)

port P3, P3.2, input/output with Schmitt-trigger

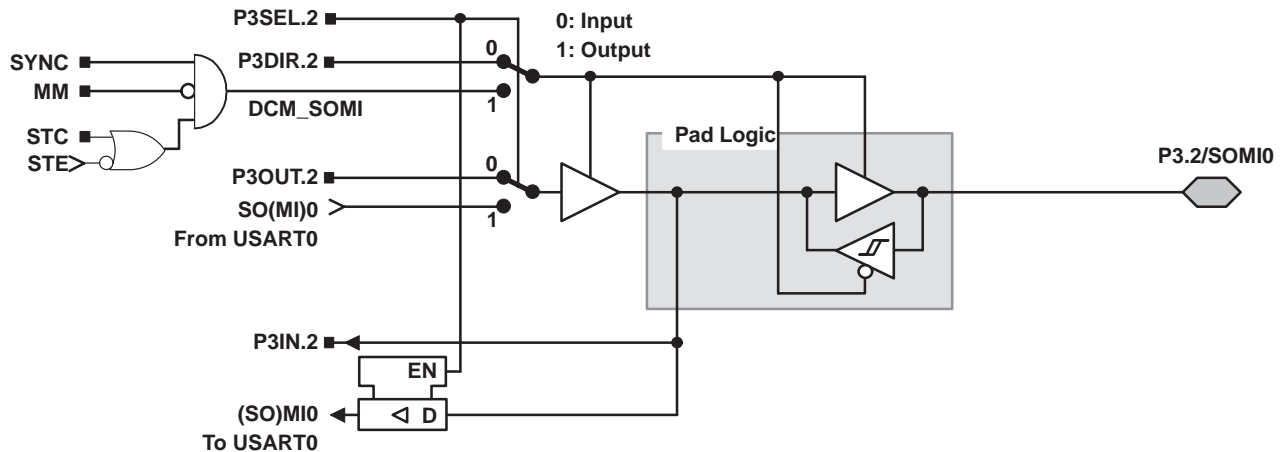

port P3, P3.3, input/output with Schmitt-trigger

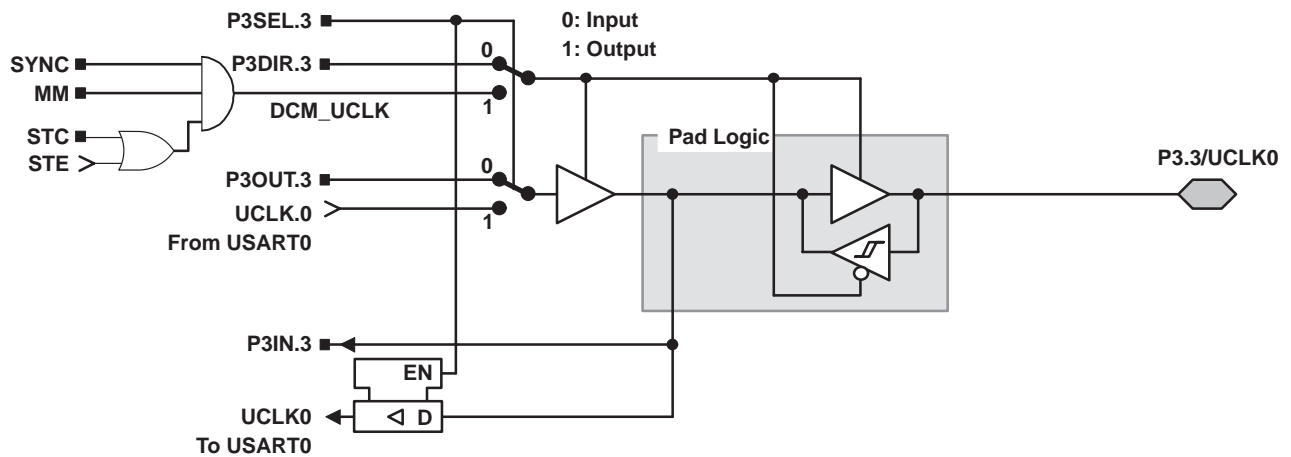

NOTE: UART mode: The UART clock can only be an input. If UART mode and UART function are selected, the P3.3/UCLK0 is always an input.  
 SPI, slave mode: The clock applied to UCLK0 is used to shift data in and out.  
 SPI, master mode: The clock to shift data in and out is supplied to connected devices on pin P3.3/UCLK0 (in slave mode).

# MSP430x13x, MSP430x14x MIXED SIGNAL MICROCONTROLLER

SLAS272A – JULY 2000 – REVISED JULY 2000

## input/output schematic (continued)

port P4, P4.0 to P4.6, input/output with Schmitt-trigger

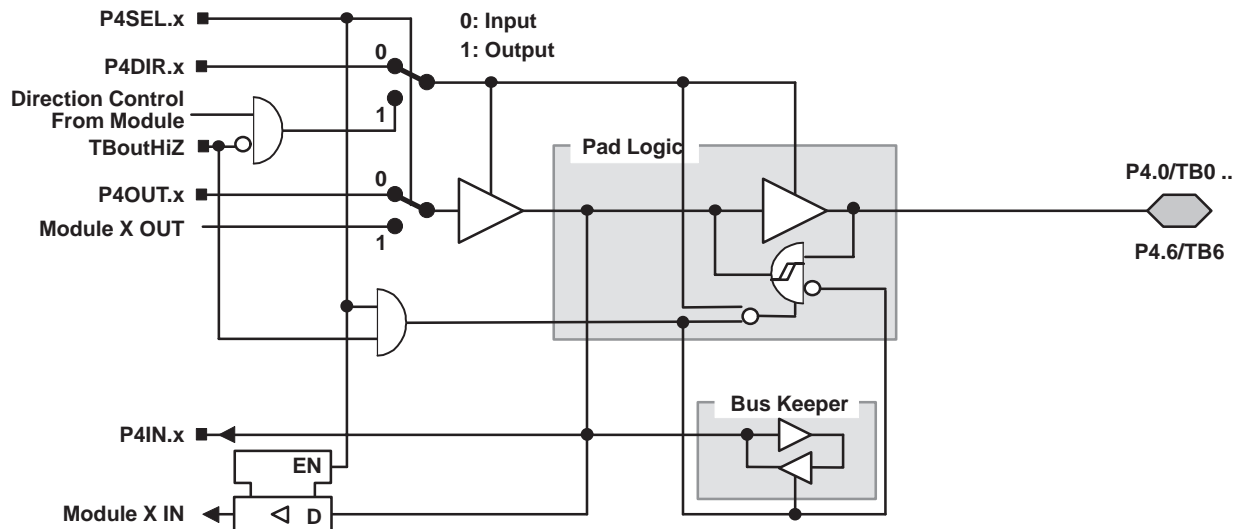

x: bit identifier, 0 to 6 for Port P4

PnSel.x	PnDIR.x	DIRECTION CONTROL FROM MODULE	PnOUT.x	MODULE X OUT	PnIN.x	MODULE X IN
P4Sel.0	P4DIR.0	P4DIR.0	P4OUT.0	Out0 signal†	P4IN.0	CCI0A / CCI0B‡
P4Sel.1	P4DIR.1	P4DIR.1	P4OUT.1	Out1 signal†	P4IN.1	CCI1A / CCI1B‡
P4Sel.2	P4DIR.2	P4DIR.2	P4OUT.2	Out2 signal†	P4IN.2	CCI2A / CCI2B‡
P4Sel.3	P4DIR.3	P4DIR.3	P4OUT.3	Out3 signal†	P4IN.3	CCI3A / CCI3B‡
P4Sel.4	P4DIR.4	P4DIR.4	P4OUT.4	Out4 signal†	P4IN.4	CCI4A / CCI4B‡
P4Sel.5	P4DIR.5	P4DIR.5	P4OUT.5	Out5 signal†	P4IN.5	CCI5A / CCI5B‡
P4Sel.6	P4DIR.6	P4DIR.6	P4OUT.6	Out6 signal†	P4IN.6	CCI6A / CCI6B‡

† Signal from Timer\_B

‡ Signal to Timer\_B

PRODUCT PREVIEW

input/output schematic (continued)

port P4, P4.7, input/output with Schmitt-trigger

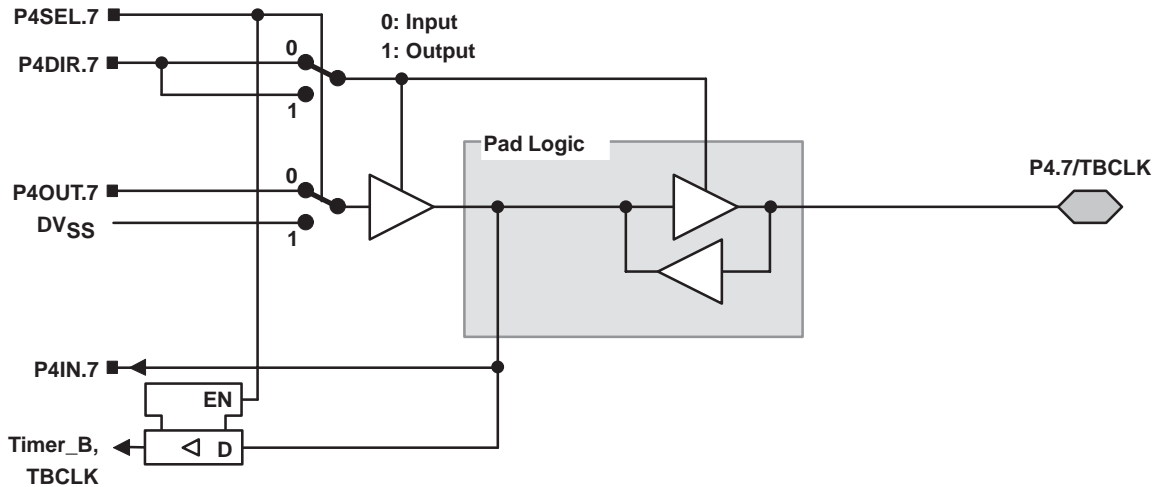

port P5, P5.0 and P5.4 to P5.7, input/output with Schmitt-trigger

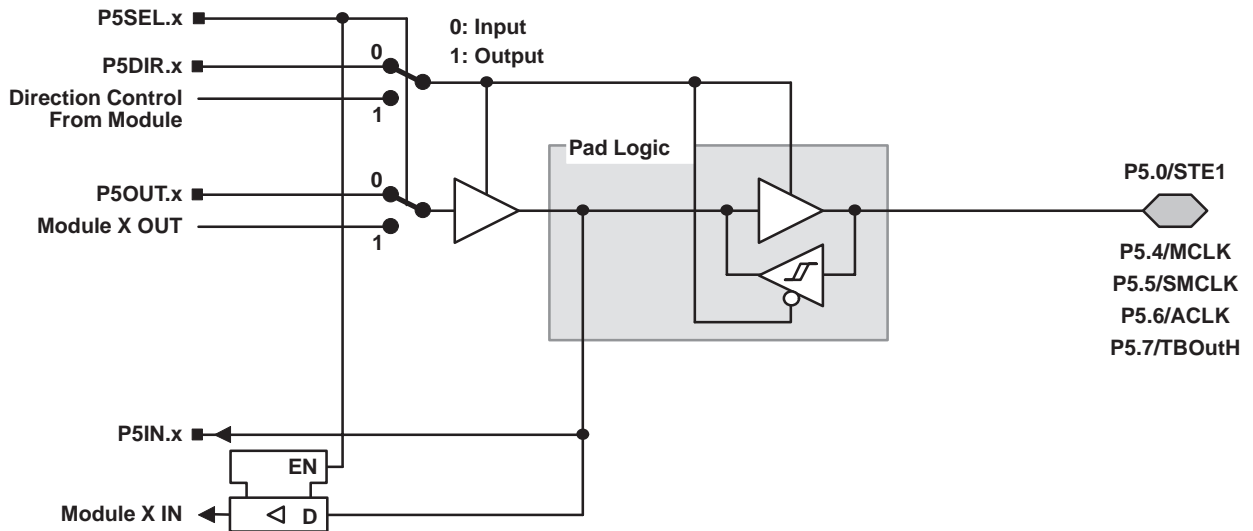

x: Bit Identifier, 0 and 4 to 7 for Port P5

PnSel.x	PnDIR.x	Dir. CONTROL FROM MODULE	PnOUT.x	MODULE X OUT	PnIN.x	MODULE X IN	PnIE.x	PnIFG.x	PnIES.x
P5Sel.0	P5DIR.0	DVSS	P5OUT.0	DVSS	P5IN.0	STE.1	P5IE.0	P5IFG.0	P5IES.0
P5Sel.4	P5DIR.4	DVCC	P5OUT.4	MCLK	P5IN.4	unused	P5IE.4	P5IFG.4	P5IES.4
P5Sel.5	P5DIR.5	DVCC	P5OUT.5	SMCLK	P5IN.5	unused	P5IE.5	P5IFG.5	P5IES.5
P5Sel.6	P5DIR.6	DVCC	P5OUT.6	ACLK	P5IN.6	unused	P5IE.6	P5IFG.6	P5IES.6
P5Sel.7	P5DIR.7	DVSS	P5OUT.7	DVSS	P5IN.7	TBoutHiZ	P5IE.7	P5IFG.7	P5IES.7

NOTE: TBoutHiZ signal is used by port module P4, pins P4.0 to P4.6. The function of TboutHiZ is mainly useful when used with Timer\_B7.

# MSP430x13x, MSP430x14x MIXED SIGNAL MICROCONTROLLER

SLAS272A – JULY 2000 – REVISED JULY 2000

## input/output schematic (continued)

### port P5, P5.1, input/output with Schmitt-trigger

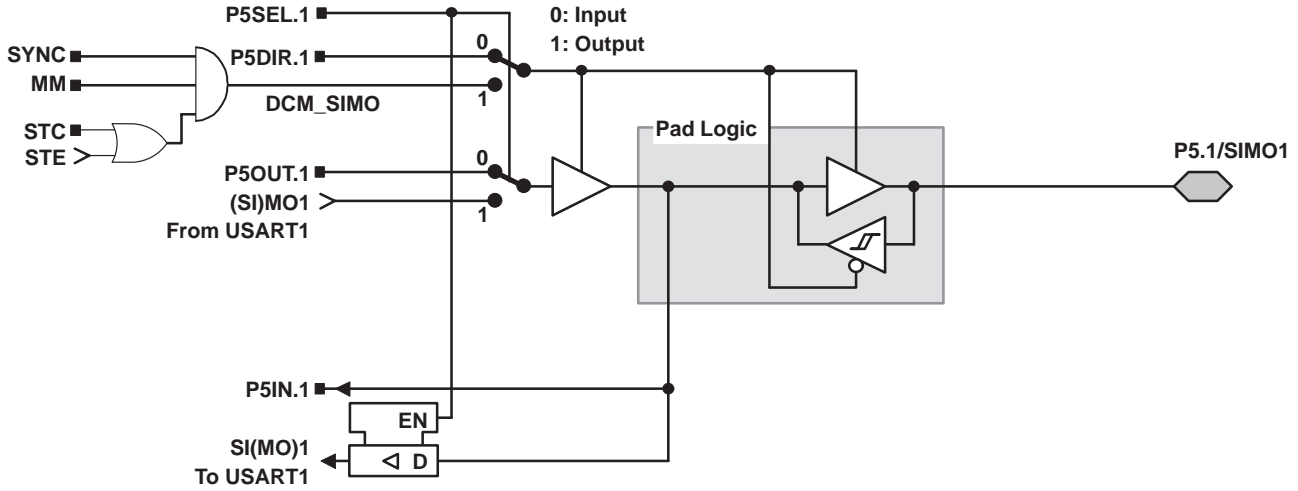

### port P5, P5.2, input/output with Schmitt-trigger

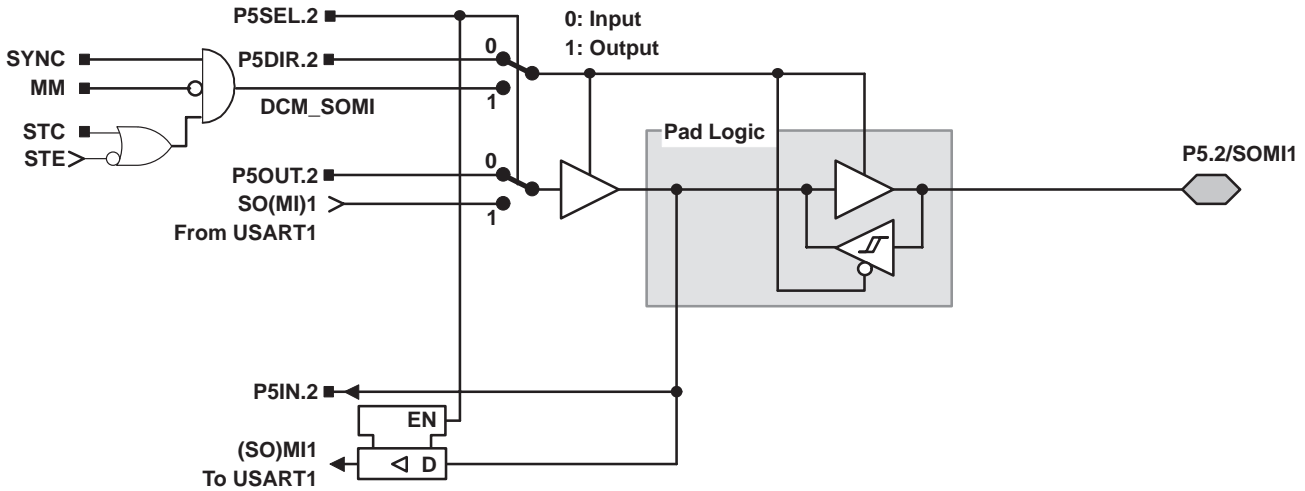

PRODUCT PREVIEW

input/output schematic (continued)

port P5, P5.3, input/output with Schmitt-trigger

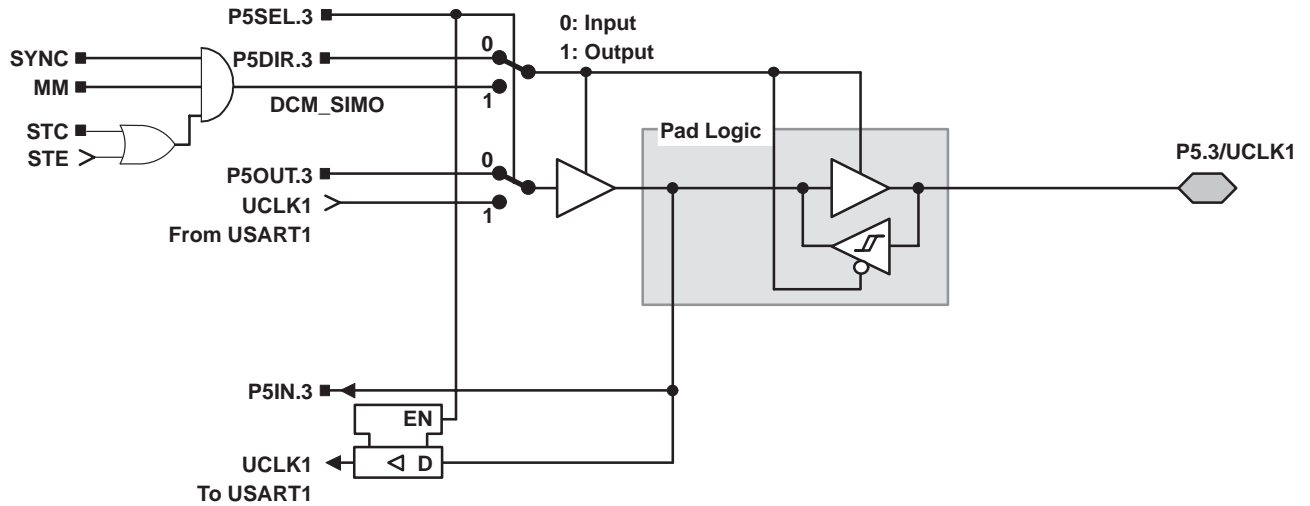

NOTE: UART mode: The UART clock can only be an input. If UART mode and UART function are selected, the P5.3/UCLK1 direction is always input.  
 SPI, slave mode: The clock applied to UCLK1 is used to shift data in and out.  
 SPI, master mode: The clock to shift data in and out is supplied to connected devices on pin P5.3/UCLK1 (in slave mode).

PRODUCT PREVIEW

# MSP430x13x, MSP430x14x MIXED SIGNAL MICROCONTROLLER

SLAS272A – JULY 2000 – REVISED JULY 2000

## input/output schematic (continued)

port P6, P6.0 to P6.7, input/output with Schmitt-trigger

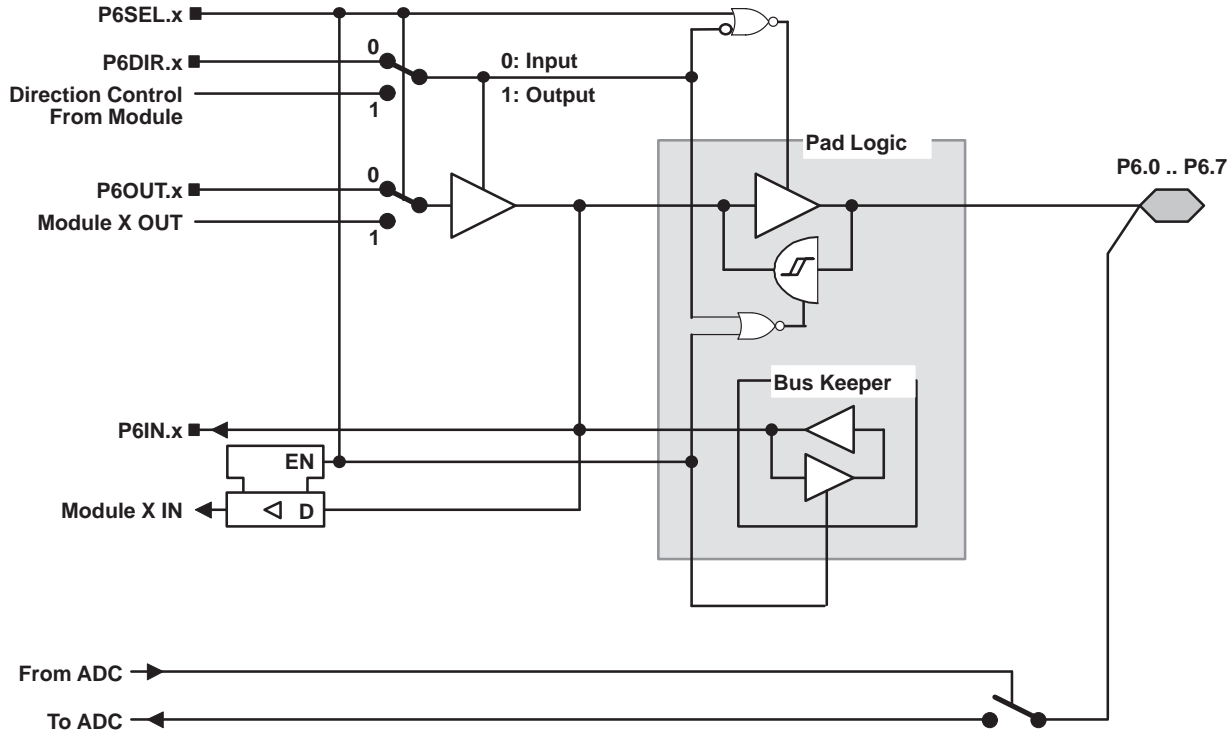

x: Bit Identifier, 0 to 7 for Port P6

NOTE: Analog signals applied to digital gates can cause current flow from the positive to the negative terminal. The throughput current flows if the analog signal is in the range of transitions 0→1 or 1←0. The value of the throughput current depends on the driving capability of the gate. For MSP430, it is approximately 100 μA.  
Use P6SEL.x=1 to prevent throughput current. P6SEL.x should be set, even if the signal at the pin is not being used by the ADC12.

PnSel.x	PnDIR.x	DIR. CONTROL FROM MODULE	PnOUT.x	MODULE X OUT	PnIN.x	MODULE X IN
P6Sel.0	P6DIR.0	P6DIR.0	P6OUT.0	DV <sub>SS</sub>	P6IN.0	unused
P6Sel.1	P6DIR.1	P6DIR.1	P6OUT.1	DV <sub>SS</sub>	P6IN.1	unused
P6Sel.2	P6DIR.2	P6DIR.2	P6OUT.2	DV <sub>SS</sub>	P6IN.2	unused
P6Sel.3	P6DIR.3	P6DIR.3	P6OUT.3	DV <sub>SS</sub>	P6IN.3	unused
P6Sel.4	P6DIR.4	P6DIR.4	P6OUT.4	DV <sub>SS</sub>	P6IN.4	unused
P6Sel.5	P6DIR.5	P6DIR.5	P6OUT.5	DV <sub>SS</sub>	P6IN.5	unused
P6Sel.6	P6DIR.6	P6DIR.6	P6OUT.6	DV <sub>SS</sub>	P6IN.6	unused
P6Sel.7	P6DIR.7	P6DIR.7	P6OUT.7	DV <sub>SS</sub>	P6IN.7	unused

NOTE: The signal at pins P6.x/Ax is used by the 12-bit ADC module.

PRODUCT PREVIEW

# MSP430x13x, MSP430x14x MIXED SIGNAL MICROCONTROLLER

SLAS272A – JULY 2000 – REVISED JULY 2000

## input/output schematic (continued)

JTAG pins TMS, TCK, TDI, TDO/TDI, input/output with Schmitt-trigger

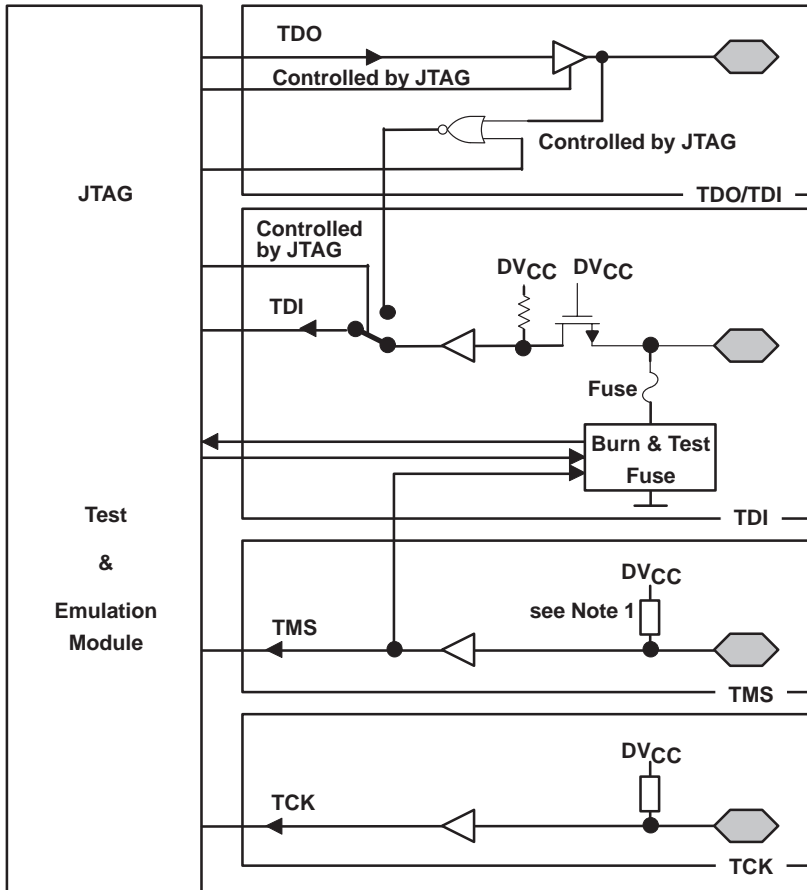

During Programming Activity and During Blowing of the Fuse, Pin TDO/TDI Is Used to Apply the Test Input Data for JTAG Circuitry

PRODUCT PREVIEW

# MSP430x13x, MSP430x14x MIXED SIGNAL MICROCONTROLLER

SLAS272A – JULY 2000 – REVISED JULY 2000

## MECHANICAL DATA

PM (S-PQFP-G64)

PLASTIC QUAD FLATPACK

PRODUCT PREVIEW

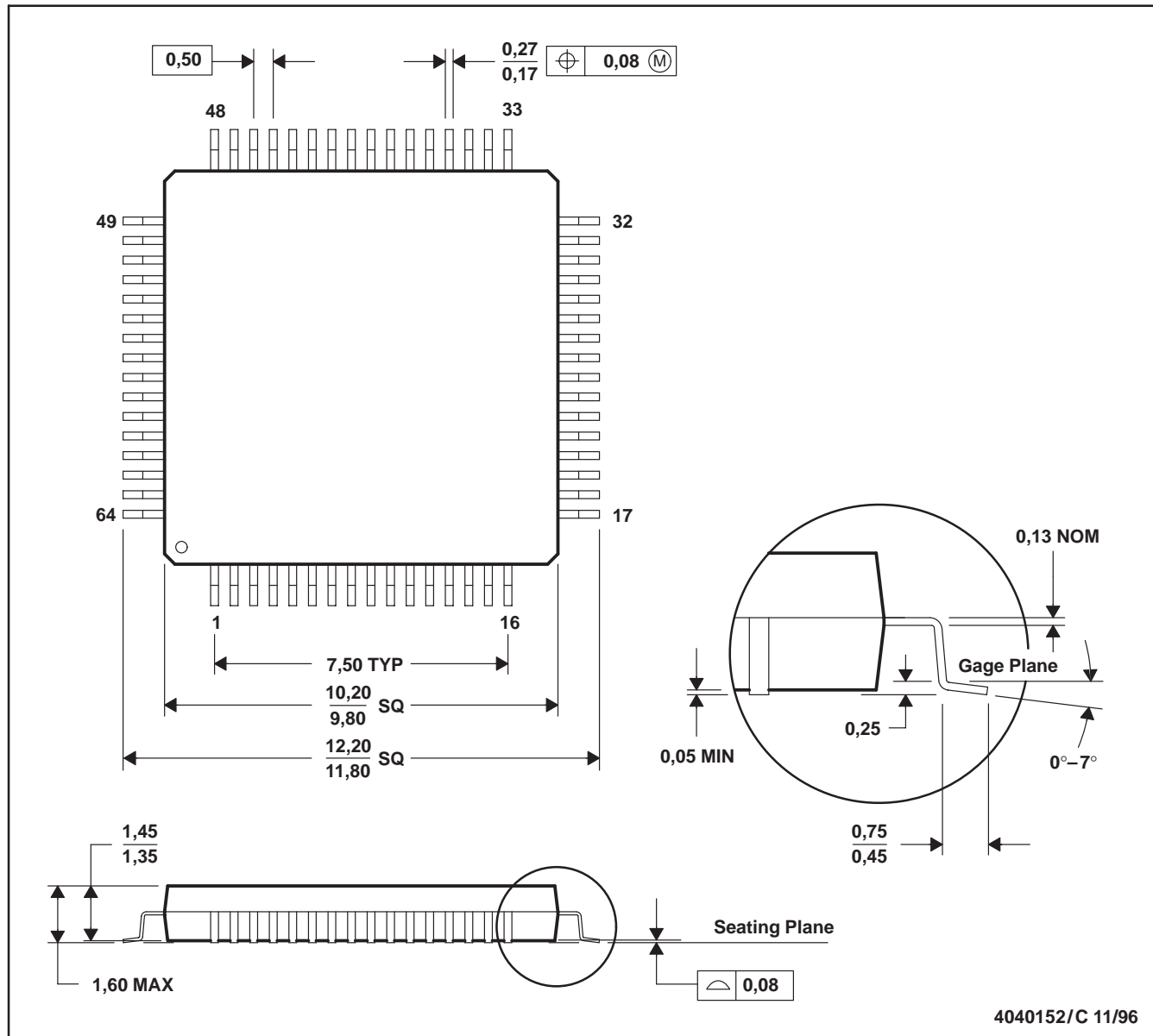

- NOTES:
- A. All linear dimensions are in millimeters.
  - B. This drawing is subject to change without notice.
  - C. Falls within JEDEC MS-026
  - D. May also be thermally enhanced plastic with leads connected to the die pads.

## **IMPORTANT NOTICE**

Texas Instruments and its subsidiaries (TI) reserve the right to make changes to their products or to discontinue any product or service without notice, and advise customers to obtain the latest version of relevant information to verify, before placing orders, that information being relied on is current and complete. All products are sold subject to the terms and conditions of sale supplied at the time of order acknowledgment, including those pertaining to warranty, patent infringement, and limitation of liability.

TI warrants performance of its semiconductor products to the specifications applicable at the time of sale in accordance with TI's standard warranty. Testing and other quality control techniques are utilized to the extent TI deems necessary to support this warranty. Specific testing of all parameters of each device is not necessarily performed, except those mandated by government requirements.

Customers are responsible for their applications using TI components.

In order to minimize risks associated with the customer's applications, adequate design and operating safeguards must be provided by the customer to minimize inherent or procedural hazards.

TI assumes no liability for applications assistance or customer product design. TI does not warrant or represent that any license, either express or implied, is granted under any patent right, copyright, mask work right, or other intellectual property right of TI covering or relating to any combination, machine, or process in which such semiconductor products or services might be or are used. TI's publication of information regarding any third party's products or services does not constitute TI's approval, warranty or endorsement thereof.