

TOSHIBA TRANSISTOR SILICON NPN EPITAXIAL TYPE (PCT PROCESS)

2SC2982

STOROBO FLASH APPLICATIONS
MEDIUM POWER AMPLIFIER APPLICATIONS

- High DC Current Gain and Excellent h_{FE} Linearity
 - : $h_{FE} (1) = 140 \sim 600$ ($V_{CE} = 1V, I_C = 0.5A$)
 - : $h_{FE} (2) = 70$ (Min.), 140 (Typ.) ($V_{CE} = 1V, I_C = 2A$)
- Low Saturation Voltage
 - : $V_{CE} (sat) = 0.5V$ (Max.) ($I_C = 2A, I_B = 50mA$)
- Small Flat Package
- $P_C = 1 \sim 2W$ (Mounted on Ceramic Substrate)

MAXIMUM RATINGS ($T_a = 25^\circ C$)

CHARACTERISTIC		SYMBOL	RATING	UNIT
Collector-Base Voltage		V_{CBO}	30	V
Collector-Emitter Voltage		V_{CES}	30	V
		V_{CEO}	10	V
Emitter-Base Voltage		V_{EBO}	6	V
Collector Current	DC	I_C	2	A
	Pulse (Note 1)	I_{CP}	4	
Base Current	DC	I_B	0.4	A
	Pulse (Note 1)	I_{BP}	0.8	
Collector Power Dissipation		P_C	500	mW
Collector Power Dissipation		P_C^*	1000	mW
Junction Temperature		T_j	150	$^\circ C$
Storage Temperature Range		T_{stg}	-55~150	$^\circ C$

Note 1 : Pulse Width $\leq 10ms$, Duty Cycle $\leq 30\%$
 P_C^* : 2SC2982 Mounted on Ceramic Substrate ($250mm^2 \times 0.8t$)

Unit in mm

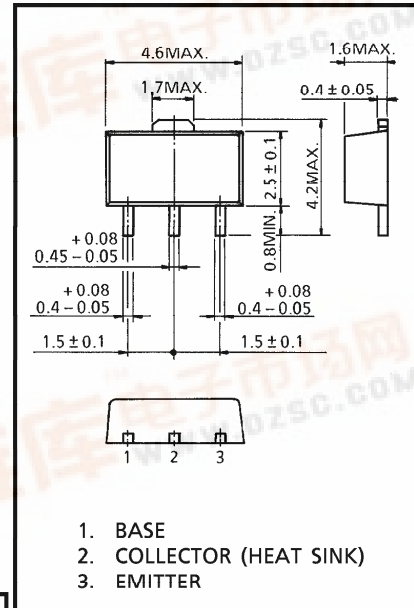

JEDEC	—
EIAJ	SC-62
TOSHIBA	2-5K1A

Weight : 0.05g

MARKING

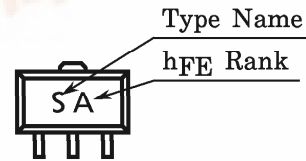

961001EAA2

● TOSHIBA is continually working to improve the quality and the reliability of its products. Nevertheless, semiconductor devices in general can malfunction or fail due to their inherent electrical sensitivity and vulnerability to physical stress. It is the responsibility of the buyer, when utilizing TOSHIBA products, to observe standards of safety, and to avoid situations in which a malfunction or failure of a TOSHIBA product could cause loss of human life, bodily injury or damage to property. In developing your designs, please ensure that TOSHIBA products are used within specified operating ranges as set forth in the most recent products specifications. Also, please keep in mind the precautions and conditions set forth in the TOSHIBA Semiconductor Reliability Handbook.

● The information contained herein is presented only as a guide for the applications of our products. No responsibility is assumed by TOSHIBA CORPORATION for any infringements of intellectual property or other rights of the third parties which may result from its use. No license is granted by implication or otherwise under any intellectual property or other rights of TOSHIBA CORPORATION or others.

● The information contained herein is subject to change without notice.

ELECTRICAL CHARACTERISTICS (Ta = 25°C)

CHARACTERISTIC	SYMBOL	TEST CONDITION	MIN.	TYP.	MAX.	UNIT
Collector Cut-off Current	I_{CBO}	$V_{CB} = 30V, I_E = 0$	—	—	100	nA
Emitter Cut-off Current	I_{EBO}	$V_{EB} = 6V, I_C = 0$	—	—	100	nA
Collector-Emitter Breakdown Voltage	$V_{(BR)CEO}$	$I_C = 10mA, I_B = 0$	10	—	—	V
Emitter-Base Breakdown Voltage	$V_{(BR)EBO}$	$I_E = 1mA, I_C = 0$	6	—	—	V
DC Current Gain	$h_{FE(1)}$ (Note 2)	$V_{CE} = 1V, I_C = 0.5A$	140	—	600	
	$h_{FE(2)}$	$V_{CE} = 1V, I_C = 2A$	70	140	—	
Collector-Emitter Saturation Voltage	$V_{CE(sat)}$	$I_C = 2A, I_B = 50mA$	—	0.2	0.5	V
Base-Emitter Voltage	V_{BE}	$V_{CE} = 1V, I_C = 2A$	—	0.86	1.5	V
Transition Frequency	f_T	$V_{CE} = 1V, I_C = 0.5A,$	—	150	—	MHz
Collector Output Capacitance	C_{ob}	$V_{CB} = 10V, I_E = 0, f = 1MHz$	—	27	—	pF

Note 2 : $h_{FE(1)}$ Classification A : 140~240, B : 200~330, C : 300~450, D : 420~600

