

**TOSHIBA**

**2SC4839**

TOSHIBA TRANSISTOR SILICON NPN EPITAXIAL PLANAR TYPE

# 2SC4839

VHF~UHF BAND LOW NOISE AMPLIFIER APPLICATIONS

Unit in mm

- Low Noise Figure, High Gain.
- $NF = 1.1dB$ ,  $|S_{21e}|^2 = 12dB$  ( $f = 1GHz$ )

MAXIMUM RATINGS ( $T_a = 25^\circ C$ )

CHARACTERISTIC	SYMBOL	RATING	UNIT
Collector-Base Voltage	$V_{CB0}$	20	V
Collector-Emitter Voltage	$V_{CEO}$	12	V
Emitter-Base Voltage	$V_{EB0}$	3	V
Collector Current	$I_C$	80	mA
Base Current	$I_B$	40	mA
Collector Power Dissipation	$P_C$	100	mW
Junction Temperature	$T_j$	125	$^\circ C$
Storage Temperature Range	$T_{stg}$	-55~125	$^\circ C$

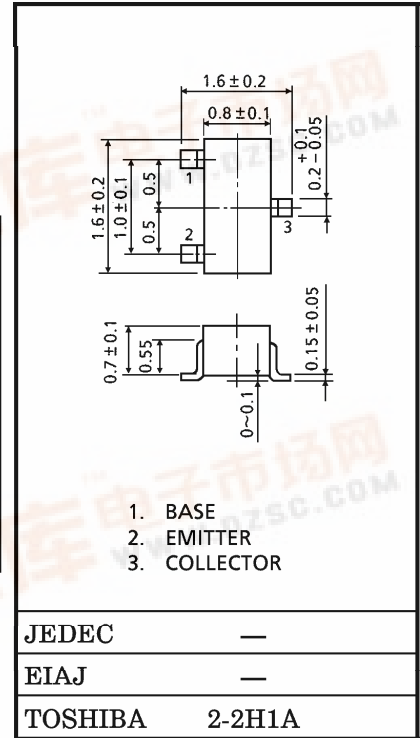

Weight : 2.4mg

Marking

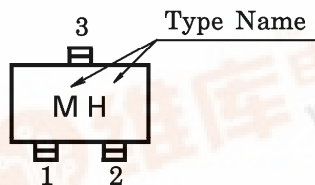

MICROWAVE CHARACTERISTICS ( $T_a = 25^\circ C$ )

CHARACTERISTIC	SYMBOL	TEST CONDITION	MIN.	TYP.	MAX.	UNIT
Transition Frequency	$f_T$	$V_{CE} = 10V, I_C = 20mA$	5	7	—	GHz
Insertion Gain	$ S_{21e} ^2 (1)$	$V_{CE} = 10V, I_C = 20mA, f = 500MHz$	—	18	—	dB
	$ S_{21e} ^2 (2)$	$V_{CE} = 10V, I_C = 20mA, f = 1GHz$	7.5	12	—	
Noise Figure	NF (1)	$V_{CE} = 10V, I_C = 5mA, f = 500MHz$	—	1	—	dB
	NF (2)	$V_{CE} = 10V, I_C = 5mA, f = 1GHz$	—	1.1	2	

ELECTRICAL CHARACTERISTICS ( $T_a = 25^\circ C$ )

CHARACTERISTIC	SYMBOL	TEST CONDITION	MIN.	TYP.	MAX.	UNIT
Collector Cut-off Current	$I_{CBO}$	$V_{CB} = 10V, I_E = 0$	—	—	1	$\mu A$
Emitter Cut-off Current	$I_{EBO}$	$V_{EB} = 1V, I_C = 0$	—	—	1	$\mu A$
DC Current Gain	$h_{FE}$	$V_{CE} = 10V, I_C = 20mA$	30	—	250	—
Output Capacitance	$C_{ob}$	$V_{CB} = 10V, I_E = 0, f = 1MHz$	—	0.85	—	pF
Reverse Transfer Capacitance	$C_{re}$	(Note)	—	0.6	1.15	PF

(Note)  $C_{re}$  is measured by 3 terminal method with capacitance bridge.

961001EAA2

- TOSHIBA is continually working to improve the quality and the reliability of its products. Nevertheless, semiconductor devices in general can malfunction or fail due to their inherent electrical sensitivity and vulnerability to physical stress. It is the responsibility of the buyer, when utilizing TOSHIBA products, to observe standards of safety, and to avoid situations in which a malfunction or failure of a TOSHIBA product could cause loss of human life, bodily injury or damage to property. In developing your designs, please ensure that TOSHIBA products are used within specified operating ranges as set forth in the most recent products specifications. Also, please keep in mind the precautions and conditions set forth in the TOSHIBA Semiconductor Reliability Handbook.
- The information contained herein is presented only as a guide for the applications of our products. No responsibility is assumed by TOSHIBA CORPORATION for any infringements of intellectual property or other rights of the third parties which may result from its use. No license is granted by implication or otherwise under any intellectual property or other rights of TOSHIBA CORPORATION or others.
- The information contained herein is subject to change without notice.

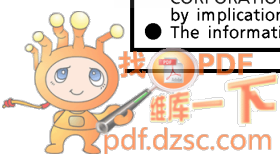

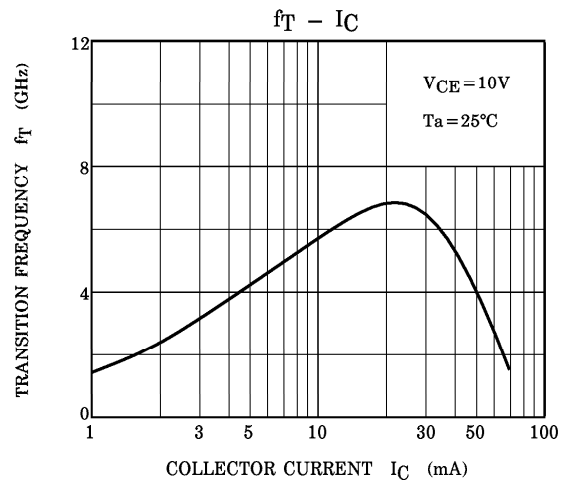
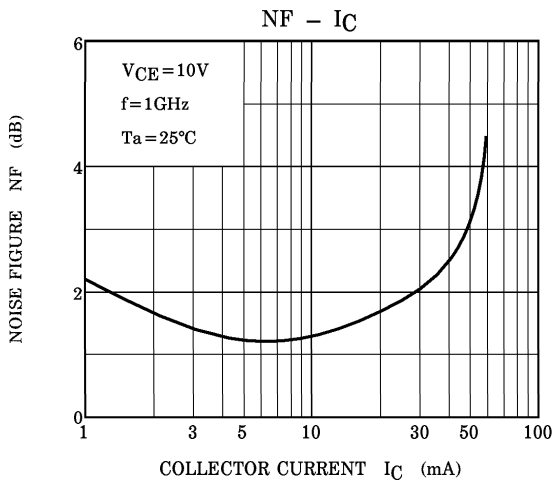
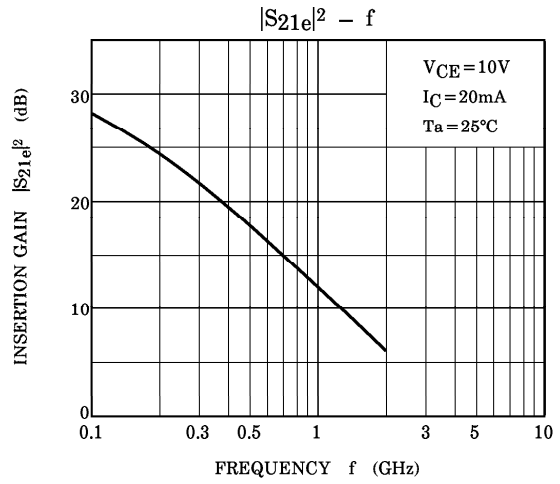
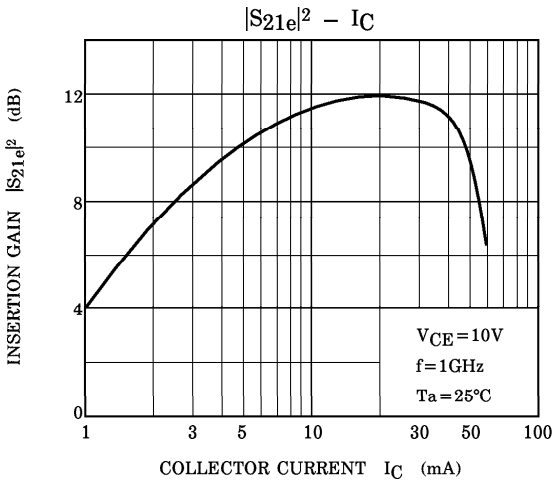
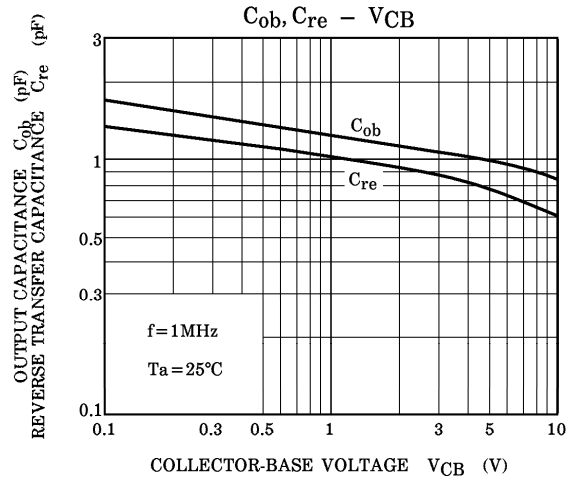
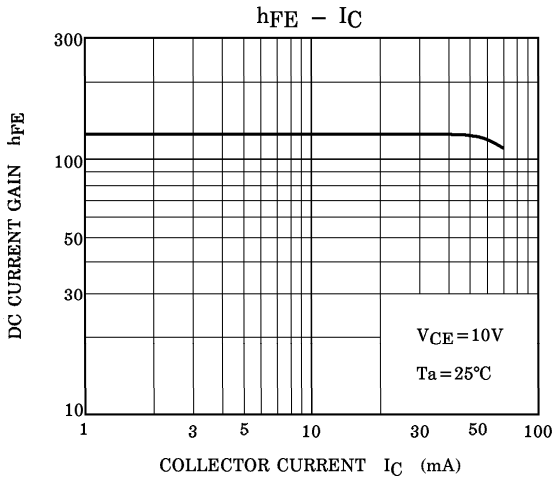

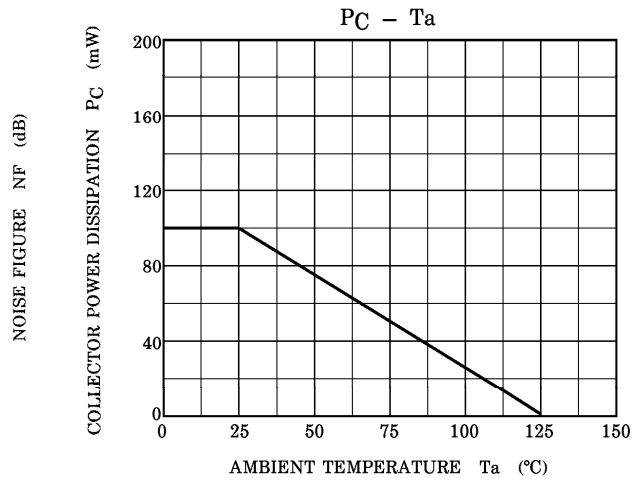
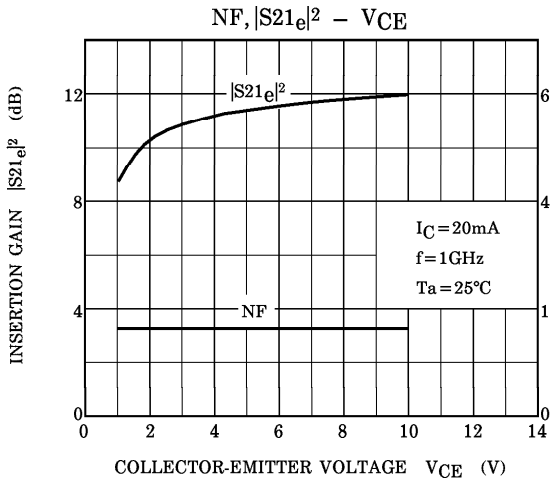

S-PARAMETER  $Z_0 = 50\Omega$ ,  $T_a = 25^\circ\text{C}$   
 $V_{CE} = 10\text{V}$ ,  $I_C = 5\text{mA}$

FREQUENCY MHz	S11		S21		S12		S22	
	MAG	ANG	MAG	ANG	MAG	ANG	MAG	ANG
200	0.705	-67.0	9.702	132.700	0.048	57.9	0.769	-27.9
400	0.536	-109.6	6.665	109.300	0.066	50.8	0.591	-34.7
600	0.467	-135.0	4.880	96.100	0.077	52.3	0.518	-36.9
800	0.440	-151.6	3.799	87.500	0.088	56.2	0.486	-39.0
1000	0.426	-164.9	3.136	80.600	0.100	60.3	0.475	-41.5
1200	0.417	-175.0	2.668	75.000	0.113	64.2	0.469	-44.5
1400	0.412	176.5	2.349	69.800	0.129	67.6	0.469	-47.8
1600	0.405	169.0	2.099	65.100	0.147	70.4	0.470	-51.2
1800	0.399	162.8	1.916	61.100	0.168	72.2	0.474	-54.1
2000	0.393	157.9	1.777	56.900	0.190	73.5	0.474	-57.8

$V_{CE} = 10\text{V}$ ,  $I_C = 20\text{mA}$

FREQUENCY MHz	S11		S21		S12		S22	
	MAG	ANG	MAG	ANG	MAG	ANG	MAG	ANG
200	0.416	-111.00	16.818	111.100	0.032	61.30	0.504	-36.4
400	0.352	-145.90	9.121	95.900	0.051	67.10	0.382	-34.9
600	0.343	-163.20	6.289	87.800	0.070	70.90	0.352	-34.7
800	0.341	-174.70	4.772	81.800	0.090	72.80	0.342	-36.3
1000	0.341	-175.50	3.903	76.400	0.111	73.70	0.341	-39.2
1200	0.338	167.80	3.294	72.300	0.132	73.90	0.346	-41.9
1400	0.333	160.90	2.898	67.800	0.154	73.90	0.349	-45.8
1600	0.325	154.60	2.563	63.800	0.176	73.60	0.355	-49.0
1800	0.314	150.30	2.322	60.300	0.200	72.90	0.361	-51.9
2000	0.301	147.30	2.132	56.600	0.223	72.10	0.363	-55.0

$S_{11e}$   
 $V_{CE} = 10V$   
 $I_C = 5mA$   
 $T_a = 25^\circ C$   
 (UNIT :  $\Omega$ )

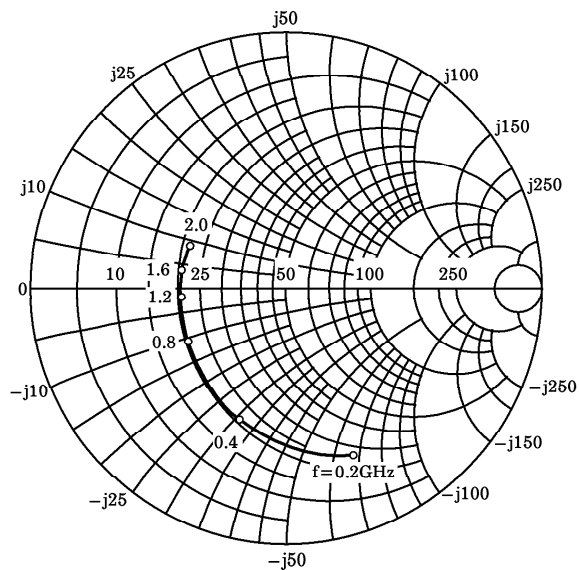

$S_{21e}$   
 $V_{CE} = 10V$   
 $I_C = 5mA$   
 $T_a = 25^\circ C$

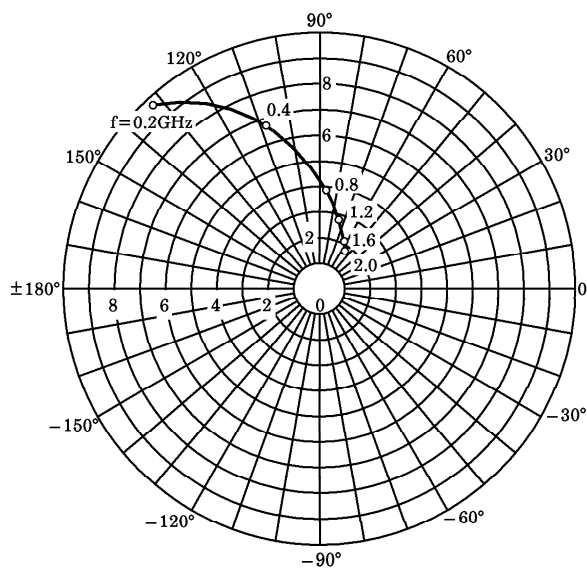

$S_{12e}$   
 $V_{CE} = 10V$   
 $I_C = 5mA$   
 $T_a = 25^\circ C$

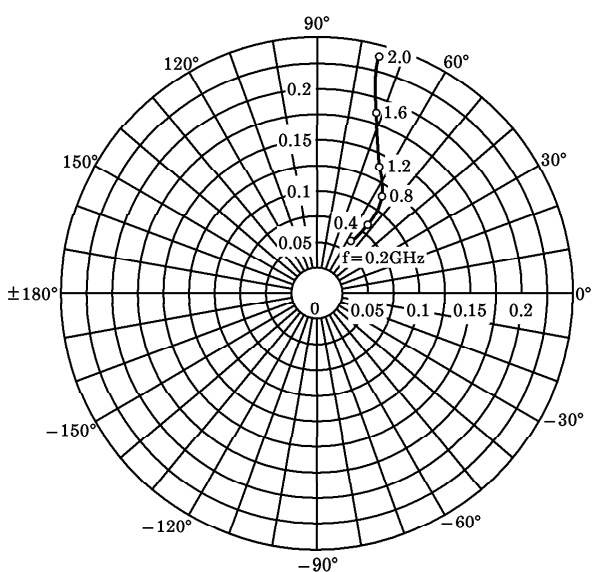

$S_{22e}$   
 $V_{CE} = 10V$   
 $I_C = 5mA$   
 $T_a = 25^\circ C$   
 (UNIT :  $\Omega$ )

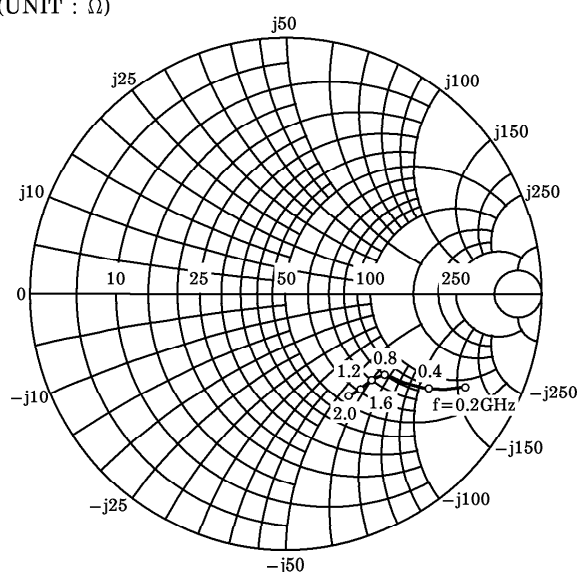

$S_{11e}$   
 $V_{CE} = 10V$   
 $I_C = 20mA$   
 $T_a = 25^\circ C$   
 (UNIT :  $\Omega$ )

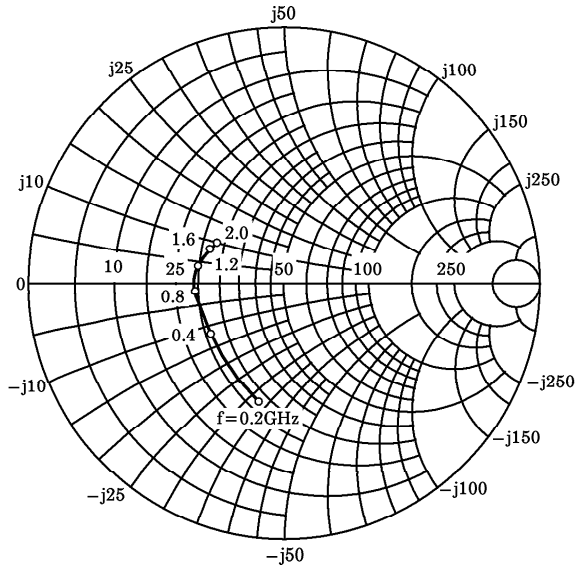

$S_{21e}$   
 $V_{CE} = 10V$   
 $I_C = 20mA$   
 $T_a = 25^\circ C$

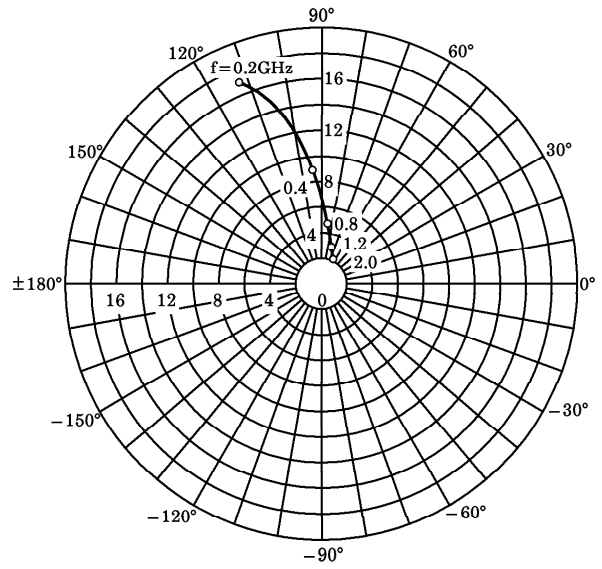

$S_{12e}$   
 $V_{CE} = 10V$   
 $I_C = 20mA$   
 $T_a = 25^\circ C$

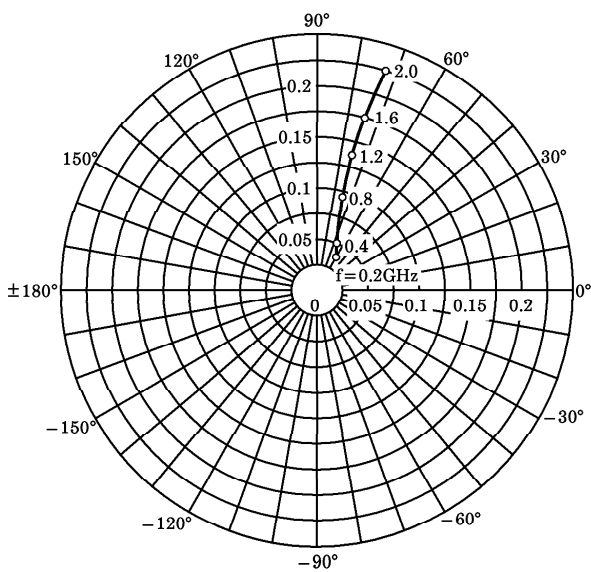

$S_{22e}$   
 $V_{CE} = 10V$   
 $I_C = 20mA$   
 $T_a = 25^\circ C$   
 (UNIT :  $\Omega$ )

