

**TOSHIBA**

**SG2500EX24**

TOSHIBA GATE TURN-OFF THYRISTOR

# SG2500EX24

INVERTER APPLICATION

- Repetitive Peak Off-State Voltage :  $V_{DRM}=2500V$
- R.M.S On-State Current :  $I_T(RMS)=1050A$
- Peak Turn-Off Current :  $I_{TGQM}=2500A$
- Critical Rate of Rise of On-State Current :  $di/dt=300A/\mu s$
- Critical Rate of Rise of Off-State Voltage :  $dv/dt=1000V/\mu s$

MAXIMUM RATINGS

| CHARACTERISTIC  | SYMBOL       | RATING   | UNIT        |
|---|--------------|----------|-------------|
| Repetitive Peak Off-State Voltage<br>(Note 1)   | $V_{DRM}$    | 2500     | V           |
| Repetitive Peak Reverse Voltage   | $V_{RRM}$    | 16       | V           |
| Peak Turn-Off Current<br>(Note 2)   | $I_{TGQM}$   | 2500     | A           |
| R.M.S On-State Current<br>(Note 3)  | $I_T(RMS)$   | 1050     | A           |
| Peak One Cycle Surge On-State Current<br>(Non-Repetitive, 10ms-Width Half Sine<br>Waveform) | $I_{TSM}$    | 14000    | A           |
| Critical Rate of Rise of On-State Current<br>(Note 4)                                       | $di/dt$      | 300      | A / $\mu s$ |
| Peak Forward Gate Current   | $I_{FGM}$    | 70       | A           |
| Average Forward Gate Power Dissipation  | $P_{FG(AV)}$ | 14       | W           |
| Average Reverse Gate Power Dissipation  | $P_{RG(AV)}$ | 120      | W           |
| R.M.S Gate Current<br>(Note 5)  | $I_G(RMS)$   | 42       | A           |
| Peak Reverse Gate Voltage<br>(at Static)  | $V_{RGM}$    | 16       | V           |
| Operating Junction Temperature Range  | $T_j$        | -40~125  | °C          |
| Storage Temperature Range   | $T_{stg}$    | -40~150  | °C          |
| Mounting Force  | —            | 20.6±2.9 | kN          |

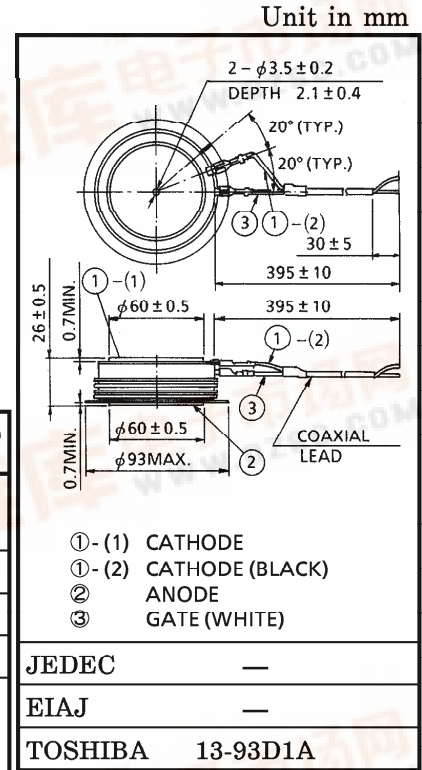

Weight : 800g

Note 1  $R_{GK}=10\Omega$

Note 2  $V_{DM}=2500V, C_S=6\mu F, R_S=5\Omega, di_{GQ}/dt=40A/\mu s, V_{DSP}\leq 600V, L_S\leq 0.3\mu H$

Note 3 50Hz Half Sine Waveform at  $T_f=76^\circ C$

Note 4  $V_D=1/2 V_{DRM}, I_{GM}=30A$

Note 5 Ambient Temperature of coaxial gate-cathode lead =  $90^\circ C$

961001EAA2

- TOSHIBA is continually working to improve the quality and the reliability of its products. Nevertheless, semiconductor devices in general can malfunction or fail due to their inherent electrical sensitivity and vulnerability to physical stress. It is the responsibility of the buyer, when utilizing TOSHIBA products, to observe standards of safety, and to avoid situations in which a malfunction or failure of a TOSHIBA product could cause loss of human life, bodily injury or damage to property. In developing your designs, please ensure that TOSHIBA products are used within specified operating ranges as set forth in the most recent products specifications. Also, please keep in mind the precautions and conditions set forth in the TOSHIBA Semiconductor Reliability Handbook.
- The information contained herein is presented only as a guide for the applications of our products. No responsibility is assumed by TOSHIBA CORPORATION for any infringements of intellectual property or other rights of the third parties which may result from its use. No license is granted by implication or otherwise under any intellectual property or other rights of TOSHIBA CORPORATION or others.
- The information contained herein is subject to change without notice.



## ELECTRICAL CHARACTERISTICS

| CHARACTERISTIC                             | SYMBOL                   | TEST CONDITION   | MIN.                      | TYP. | MAX.  | UNIT                      |   |
|--|--------------------------|--|---------------------------|------|-------|---------------------------|---|
| Repetitive Peak Off-State Current          | $I_{DRM}$                | $V_{DRM} = \text{Rated}$ , $R_{GK} = 10\Omega$ ,<br>$T_j = 125^\circ\text{C}$  | —                         | —    | 50    | mA                        |   |
| Repetitive Peak Reverse Current            | $I_{RRM}$                | $V_{RRM} = \text{Rated}$ ,<br>$T_j = 125^\circ\text{C}$  | —                         | —    | 10    | mA                        |   |
| Repetitive Peak Reverse Gate Current       | $I_{RGM}$                | $V_{RGM} = 16\text{V}$ , $T_j = 125^\circ\text{C}$   | —                         | —    | 10    | mA                        |   |
| Peak On-State Voltage                      | $V_{TM}$                 | $I_{TM} = 2500\text{A}$ , $T_j = 125^\circ\text{C}$  | —                         | —    | 2.65  | V                         |   |
| Gate Trigger Voltage                       | $V_{GT}$                 | $V_D = 24\text{V}$ ,<br>$R_L = 0.1\Omega$  | $T_j = -40^\circ\text{C}$ | —    | —     | 1.50                      | V |
|  | $T_j = 25^\circ\text{C}$ |  | —                         | —    | 1.00  |                           |   |
| Gate Trigger Current                       | $I_{GT}$                 |  | $T_j = -40^\circ\text{C}$ | —    | —     | 7.0                       | A |
|  | $T_j = 25^\circ\text{C}$ |  | —                         | —    | 3.0   |                           |   |
| Turn-On Delay Time                         | $t_d$                    | $V_D = 1/2V_{DRM}$ ,<br>$di/dt = 300\text{A}/\mu\text{s}$ ,<br>$I_{GM} = 30\text{A}$ , $T_j = 25^\circ\text{C}$  | —                         | —    | 4     | $\mu\text{s}$             |   |
| Turn-On Time                               | $t_{gt}$                 |  | —                         | —    | 12    | $\mu\text{s}$             |   |
| Critical Rate of Rise of Off-State Voltage | $dv/dt$                  | $V_D = 2/3V_{DRM}$ ,<br>Exponential Rise,<br>$T_j = 125^\circ\text{C}$ , $V_{GK} = -2\text{V}$   | 1000                      | —    | —     | $\text{V}/\mu\text{s}$    |   |
| Storage Time                               | $t_s$                    | $I_{TGQ} = 2500\text{A}$ , $V_{DM} = 2000\text{V}$ ,<br>$V_D = 1/2V_{DRM}$ ,<br>$di_{GQ}/dt = 40\text{A}/\mu\text{s}$ ,<br>$C_S = 6\mu\text{F}$ , $R_S = 5\Omega$ ,<br>$T_j = 125^\circ\text{C}$ , $L_S \leq 0.3\mu\text{H}$ | —                         | —    | 22    | $\mu\text{s}$             |   |
| Gate Turn-Off Time                         | $t_{gq}$                 |  | —                         | —    | 25    | $\mu\text{s}$             |   |
| Tail Time                                  | $t_{tail}$               |  | —                         | 60   | —     | $\mu\text{s}$             |   |
| Gate Turn-Off Current                      | $I_{GQ}$                 |  | —                         | 520  | —     | A                         |   |
| Thermal Resistance<br>(Junction to Fin)    | $R_{th(j-f)}$            | DC   | —                         | —    | 0.020 | $^\circ\text{C}/\text{W}$ |   |

