

**TOSHIBA****TA1218AN**

TOSHIBA BIPOLAR LINEAR INTEGRATED CIRCUIT SILICON MONOLITHIC

# TA1218AN

## AUDIO / VIDEO SWITCHING IC FOR TVs

The TA1218AN is an audio/video switching IC for TV sets.

Conforming to I<sup>2</sup>C bus standards, it allows you to perform various switching operations through the bus lines by using a microcomputer. Thanks to its 2-channel outputs, the TA1218AN can also be used for the PIP systems. Furthermore, since the presence of a signal on its sync signal output pin can be determined by a microcomputer, it is possible to check each input/output channel (self-diagnosis).

This IC has the same pin assignments as the TA1219AN (SDIP36), a 1-channel output version of the TA1218AN, so these chips are pin compatible on pins 3 to 20 and 23 to 40.

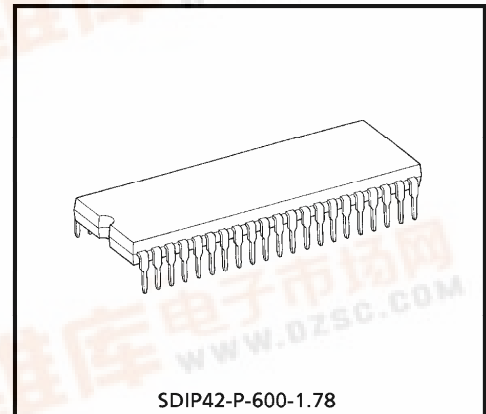

SDIP42-P-600-1.78  
Weight : 4.13g (Typ.)

### FEATURES

- I<sup>2</sup>C bus control
- Video : 5-channel inputs and 2-channel outputs (2 channels conforming to S system)
- Audio : 5-channel inputs and 3-channel outputs
- Self-diagnostic function
- ADC inputs based on European 21-pin standards
- ADC inputs based on S1/S2 terminal standards
- Switchable subaddress

961001EBA1

- TOSHIBA is continually working to improve the quality and the reliability of its products. Nevertheless, semiconductor devices in general can malfunction or fail due to their inherent electrical sensitivity and vulnerability to physical stress. It is the responsibility of the buyer, when utilizing TOSHIBA products, to observe standards of safety, and to avoid situations in which a malfunction or failure of a TOSHIBA product could cause loss of human life, bodily injury or damage to property. In developing your designs, please ensure that TOSHIBA products are used within specified operating ranges as set forth in the most recent products specifications. Also, please keep in mind the precautions and conditions set forth in the TOSHIBA Semiconductor Reliability Handbook.
- The products described in this document are subject to foreign exchange and foreign trade control laws.
- The information contained herein is presented only as a guide for the applications of our products. No responsibility is assumed by TOSHIBA CORPORATION for any infringements of intellectual property or other rights of the third parties which may result from its use. No license is granted by implication or otherwise under any intellectual property or other rights of TOSHIBA CORPORATION or others.
- The information contained herein is subject to change without notice.

BLOCK DIAGRAM

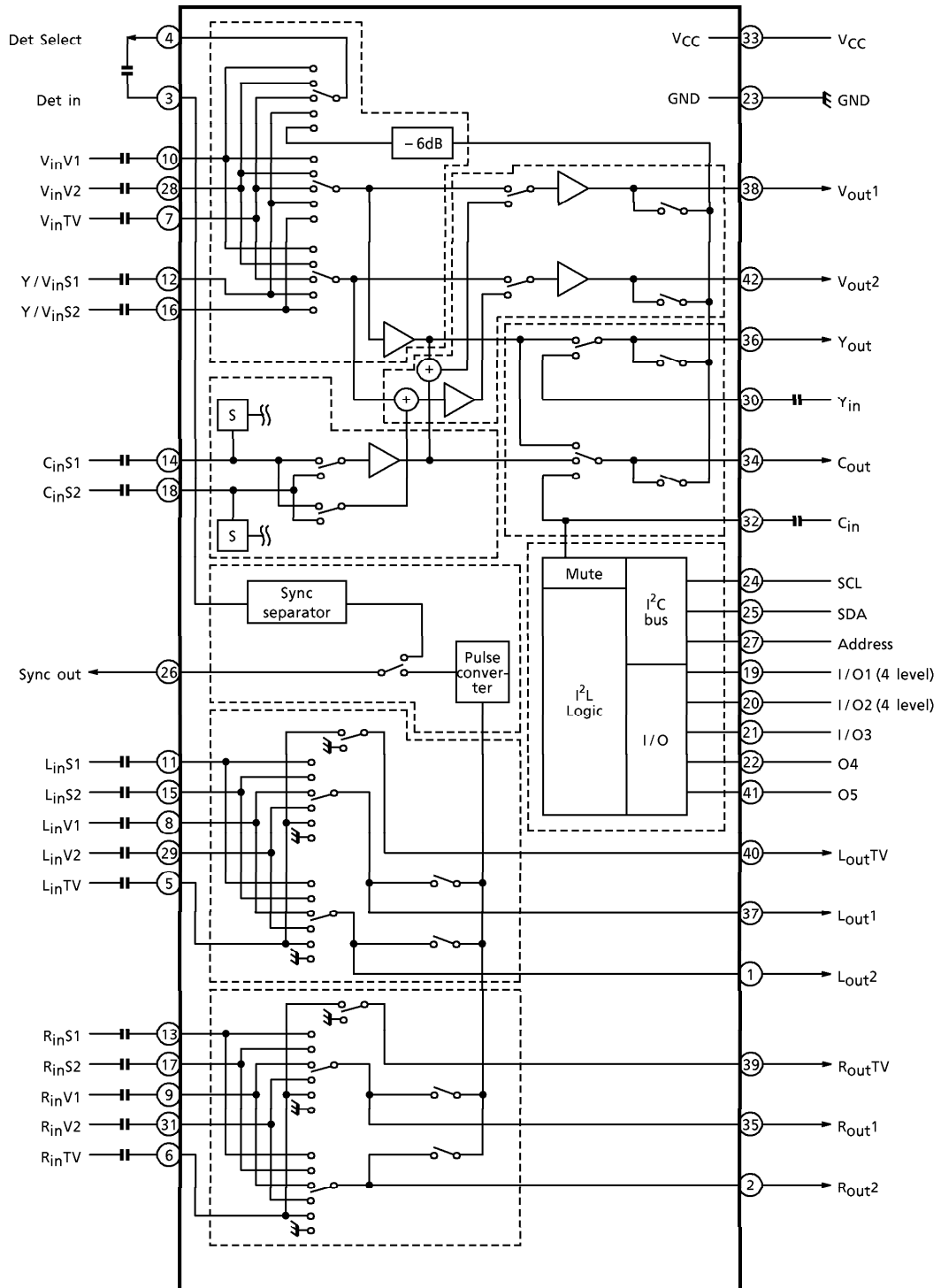

PIN ASSIGNMENT

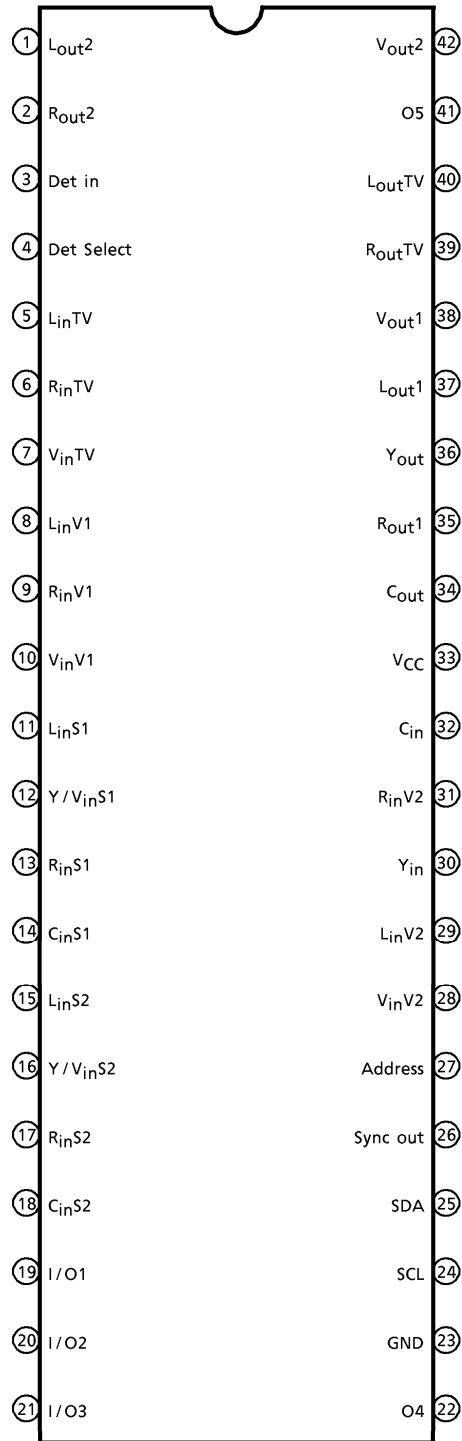

PIN DESCRIPTION

PIN No.	NAME	FUNCTION	INTERFACE
1	L <sub>out2</sub>	<p>This pin is for output a sub-channel left audio signal. The signals fed into the chip via L<sub>in</sub>V1, L<sub>in</sub>V2, L<sub>in</sub>S1, L<sub>in</sub>S2, or L<sub>in</sub>TV is output from this pin. The output resistance of this pin is 45Ω. Furthermore, the signal output from this pin is pulse-converted for use in self-diagnosis. The converted signal is output from Sync Out.</p> <p>This output can be muted in combination with R<sub>out2</sub> by bus control.</p>	
2	R <sub>out2</sub>	<p>This pin is for output a sub-channel right audio signal. The signals fed into the chip via R<sub>in</sub>V1, R<sub>in</sub>V2, R<sub>in</sub>S1, R<sub>in</sub>S2, or R<sub>in</sub>TV is output from this pin. The output resistance of this pin is 45Ω. Furthermore, the signal output from this pin is pulse-converted for use in self-diagnosis. The converted signal is output from Sync Out.</p> <p>This output can be muted in combination with L<sub>out2</sub> by bus control.</p>	
3	Det in	<p>This pin is for input a sync separation signal. Input the signal from Det Select to this pin with capacitance coupling. The input resistance of this pin is 18kΩ. The sync signal separated from Det Select is outputted from Sync Out for use in self-diagnosis.</p>	
4	Det Select	<p>This pin is for output a sync separation signal. Signals V<sub>in</sub>V1, V<sub>in</sub>V2, V<sub>in</sub>TV, Y/V<sub>in</sub>S1, V<sub>out</sub>1, V<sub>out</sub>2, Y<sub>out</sub>, or C<sub>out</sub> are outputted from this pin. The output resistance of this pin is 35Ω. Input the signal from this pin to Det in with capacitance coupling.</p>	

PIN No.	NAME	FUNCTION	INTERFACE
5	$L_{inTV}$	<p>This pin is for input a left audio signal from the main demodulator in the TV set. The signal fed into this pin is presented to <math>L_{outTV}</math>, <math>L_{out1}</math>, and <math>L_{out2}</math>. The input dynamic range of this pin is <math>6.5V_{p-p}</math> and the input resistance is <math>70k\Omega</math>.</p>	
6	$R_{inTV}$	<p>This pin is for input a right audio signal from the main demodulator in the TV set. The signal fed into this pin is presented to <math>R_{outTV}</math>, <math>R_{out1}</math>, and <math>R_{out2}</math>. The input dynamic range of this pin is <math>6.5V_{p-p}</math> and the input resistance is <math>70k\Omega</math>.</p>	
7	$V_{inTV}$	<p>This pin is for input a composite audio signal from the main demodulator in the TV set. The signal fed into this pin is presented to <math>V_{out1}</math>, <math>V_{out2}</math>, <math>Y_{out}</math>, and <math>C_{out}</math>. The same signal is also output from Det Select as a sync separation signal. The input dynamic range of this pin is <math>2.0V_{p-p}</math> and the input resistance is <math>30k\Omega</math>.</p>	
8	$L_{inV1}$	<p>This pin is for input a left audio signal from an external source (V1 channel). This pin can also be used for PIP signal input. The signal fed into this pin is presented to <math>L_{out1}</math> and <math>L_{out2}</math>. The input dynamic range of this pin is <math>6.5V_{p-p}</math> and the input resistance is <math>70\Omega</math>.</p>	

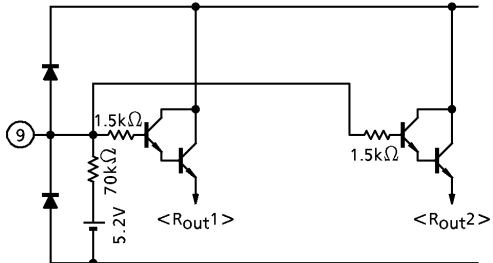
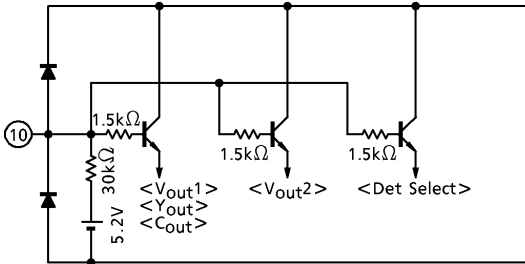
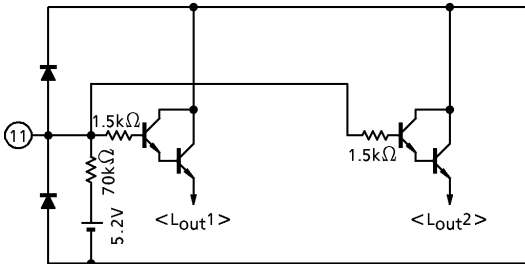
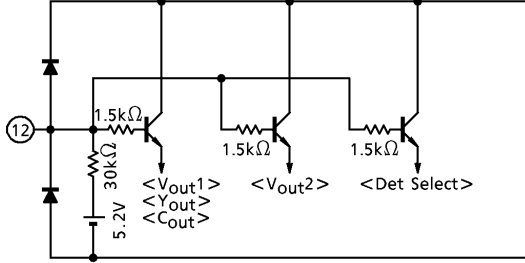
PIN No.	NAME	FUNCTION	INTERFACE
9	$R_{inV1}$	<p>This pin is for input a right audio signal from an external source (V1 channel). This pin can also be used for PIP signal input. The signal fed into this pin is presented to <math>R_{out1}</math> and <math>R_{out2}</math>.</p> <p>The input dynamic range of this pin is <math>6.5V_{p-p}</math> and the input resistance is <math>70k\Omega</math>.</p>	
10	$V_{inV1}$	<p>This pin is for input a composite video signal from an external source (V1 channel). This pin can also be used for PIP signal input. The signal fed into this pin is presented to <math>V_{out1}</math>, <math>V_{out2}</math>, <math>Y_{out}</math>, and <math>C_{out}</math>. The same signal is also output from Det Select as a sync separation signal.</p> <p>The input dynamic range of this pin is <math>2.0V_{p-p}</math> and the input resistance is <math>30k\Omega</math>.</p>	
11	$L_{inS1}$	<p>This pin is for input a left audio signal from an external source (S1 channel). The signal fed into this pin is presented to <math>L_{out1}</math> and <math>L_{out2}</math>.</p> <p>The input dynamic range of this pin is <math>6.5V_{p-p}</math> and the input resistance is <math>70k\Omega</math>.</p>	
12	$Y/V_{inS1}$	<p>This pin is for input a luminance signal or composite video signal from an external source (S1 channel). The signal fed into this pin is presented to <math>V_{out1}</math>, <math>V_{out2}</math>, <math>Y_{out}</math>, and <math>C_{out}</math>. The same signal is also output from Det Select as a sync separation signal.</p> <p>The input dynamic range of this pin is <math>2.0V_{p-p}</math> and the input resistance is <math>30k\Omega</math>.</p>	

PIN No.	NAME	FUNCTION	INTERFACE
13	R <sub>in</sub> S1	<p>This pin is for input a right audio signal from an external source (S1 channel). The signal fed into this pin is presented to R<sub>out</sub>1 and R<sub>out</sub>2. The input dynamic range of this pin is 6.5V<sub>p-p</sub> and the input resistance is 70kΩ.</p>	
14	C <sub>in</sub> S1	<p>This pin is for input a chroma signal from an external source (S1 channel). It also functions as an S-mode select switch for the S1 channel. The S mode is selected when the pin voltage is DC opened. The signal fed into this pin is presented to C<sub>out</sub> directly and to V<sub>out</sub>1 and V<sub>out</sub>2 after being combined with the Y<sub>in</sub>S1 signal. The input dynamic range of this pin is 2.0V<sub>p-p</sub> and the input resistance is 30kΩ.</p>	
15	L <sub>in</sub> S2	<p>This pin is for input a left audio signal from an external source (S2 channel). The signal fed into this pin is presented to L<sub>out</sub>1 and L<sub>out</sub>2. The input dynamic range of this pin is 6.5V<sub>p-p</sub> and the input resistance is 70kΩ.</p>	
16	Y/V <sub>in</sub> S2	<p>This pin is for input a luminance signal or composite audio signal from an external source (S2 channel). The signal fed into this pin is presented to V<sub>out</sub>1, V<sub>out</sub>2, Y<sub>out</sub>, and C<sub>out</sub>. The input dynamic range of this pin is 2.0V<sub>p-p</sub> and the input resistance is 30kΩ.</p>	

PIN No.	NAME	FUNCTION	INTERFACE
17	R <sub>in</sub> S2	<p>This pin is for input a right audio signal from an external source (S2 channel). The signal fed into this pin is presented to R<sub>out</sub>1 and R<sub>out</sub>2. The input dynamic range of this pin is 6.5V<sub>p-p</sub> and the input resistance is 70kΩ.</p>	
18	C <sub>in</sub> S2	<p>This pin is for input a chroma signal from an external source (S2 channel). It also functions as an S-mode select switch for the S2 channel. The S mode is selected when the pin voltage is DC opened. The signal fed into this pin is presented to C<sub>out</sub> directly and to V<sub>out</sub>1 and V<sub>out</sub>2 after being combined with the Y<sub>in</sub>S2 signal. The input dynamic range of this pin is 2.0V<sub>p-p</sub> and the input resistance is 30kΩ.</p>	
19	I/O1	<p>This is an ADC input/DAC output pin. The ADC is a 4-level detection type (2 bits). The threshold levels are 8.0V, 3.0V, and 0.75V. The DAC (1bit) is an open-collector output. Make sure that the current flowing into this pin is 2.0mA or less.</p>	
20	I/O2	<p>This is an ADC input/DAC output pin. The ADC is a 4-level detection type (2 bits). The threshold levels are 8.0V, 3.0V, and 0.75V. The DAC (1bit) is an open-collector output. Make sure that the current flowing into this pin is 2.0mA or less.</p>	

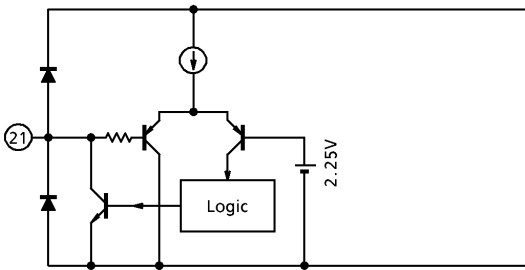
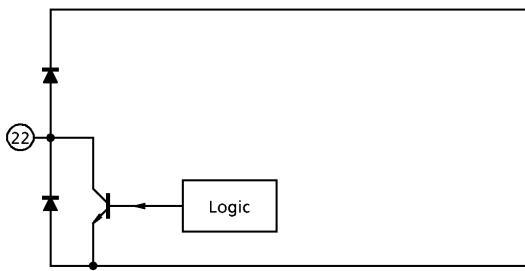
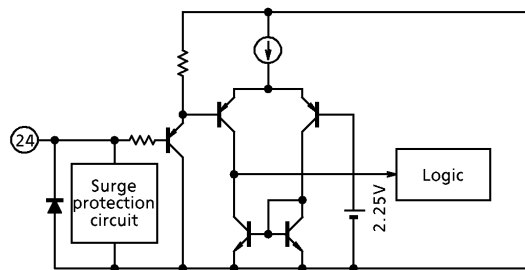
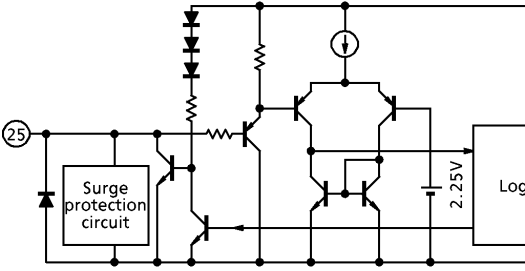

PIN No.	NAME	FUNCTION	INTERFACE
21	I/O3	<p>This is an ADC input/DAC output pin.</p> <p>The ADC is a 2-level detection type (1bit). The threshold level is 2.25V.</p> <p>The DAC (1bit) is an open-collector output. Make sure that the current flowing into this pin is 2.0mA or less.</p>	
22	O4	<p>This pin is for a 1bit DAC output.</p> <p>This is an open-collector output. Make sure that the current flowing into this pin is 2.0mA or less.</p>	
23	GND	<p>This is the GND pin.</p>	<p style="text-align: center;">—</p>
24	SCL	<p>This pin is for input an I<sup>2</sup>C bus clock. The input threshold level of this pin is 2.25V.</p>	
25	SDA	<p>This is an I<sup>2</sup>C bus data input/output pin. The input threshold level of this pin is 2.25V.</p> <p>Make sure that the current flowing into this pin is 3.0mA or less.</p>	

PIN No.	NAME	FUNCTION	INTERFACE
26	Sync out	<p>This pin is for output a self-diagnostic sync signal. The signal separated from <math>V_{inTV}</math>, <math>V_{inV1}</math>, <math>V_{inV2}</math>, <math>Y/V_{inS1}</math>, <math>V_{out1}</math>, <math>V_{out2}</math>, <math>Y_{out}</math>, or <math>C_{out}</math> is outputted from this pin. In addition, the signal derived from <math>L_{out1}</math>, <math>R_{out1}</math>, <math>L_{out2}</math>, or <math>R_{out2}</math> is also output from this pin for use in audio block diagnosis.</p> <p>This is an open-collector output. Make sure that the current flowing into this pin is 2.0mA or less.</p>	
27	Address	<p>This is for an I<sup>2</sup>C bus slave address select switch. The threshold level of this pin is 2.25V. The following lists the addresses :</p> <p>High : 92H (Write), 93H (Read)</p> <p>Low : 90H (Write), 91H (Read)</p>	
28	$V_{inV2}$	<p>This pin is for input a composite video signal from an external source (V2 channel). This pin can also be used for PIP signal input. The signal fed into this pin is presented to <math>V_{out1}</math>, <math>V_{out2}</math>, <math>Y_{out}</math>, and <math>C_{out}</math>. The same signal is also output from Det Select as a sync separation signal.</p> <p>The input dynamic range of this pin is 2.0V<sub>p-p</sub> and the input resistance is 30kΩ.</p>	
29	$L_{inV2}$	<p>This pin is for input a left audio signal from an external source (V2 channel). This pin can also be used for PIP signal input. The signal fed into this pin is presented to <math>L_{out1}</math> and <math>L_{out2}</math>.</p> <p>The input dynamic range of this pin is 6.5V<sub>p-p</sub> and the input resistance is 70kΩ.</p>	

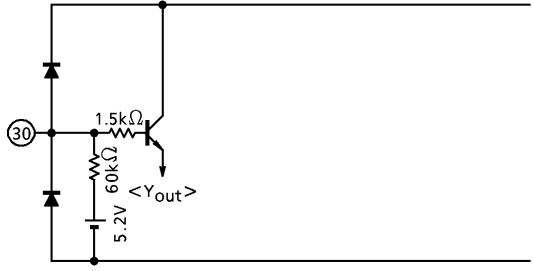
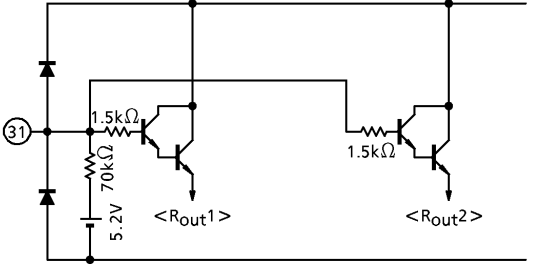
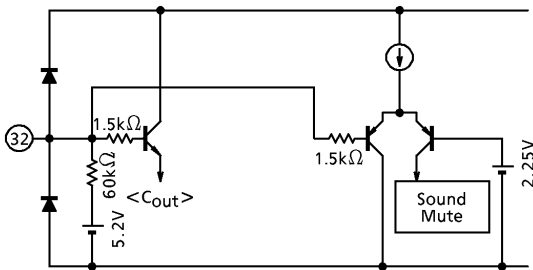
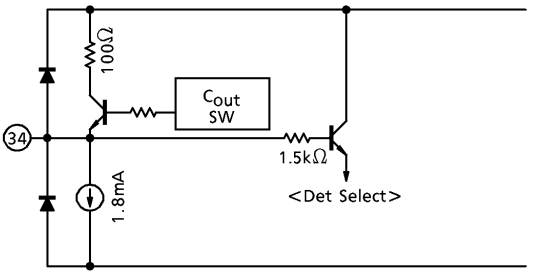
PIN No.	NAME	FUNCTION	INTERFACE
30	$Y_{in}$	<p>This pin is for input a luminance signal from an external comb filter. The signal fed into this pin is presented to <math>Y_{out}</math>. The input dynamic range of this pin is <math>5.5V_{p-p}</math> and the input resistance is <math>60k\Omega</math>.</p>	
31	$R_{inV2}$	<p>This pin is for input a right audio signal from an external source (V2 channel). This pin can also be used for PIP signal input. The signal fed into this pin is presented to <math>R_{out1}</math> and <math>R_{out2}</math>. The input dynamic range of this pin is <math>6.5V_{p-p}</math> and the input resistance is <math>70k\Omega</math>.</p>	
32	$C_{in}$	<p>This pin is for input a chroma signal from an external comb filter. The signal fed into this pin is presented to <math>C_{out}</math>. The input dynamic range of this pin is <math>5.5V_{p-p}</math> and the input resistance is <math>60k\Omega</math>. This pin also functions as a audio mute switch. The entire audio output can be muted by pulling the voltage on this pin below <math>2.25V</math>.</p>	
33	$V_{CC}$	<p>This is the power supply pin. Apply <math>9V</math> to this pin. The current consumption of this pin is <math>47mA</math>.</p>	<p style="text-align: center;">—</p>
34	$C_{out}$	<p>This pin is for output a chroma signal. The signal fed into <math>C_{in}</math>, <math>C_{inS1}</math>, <math>C_{inS2}</math>, <math>V_{inV1}</math>, <math>V_{inV2}</math>, <math>Y/V_{inS1}</math>, <math>Y/V_{inS2}</math>, or <math>V_{inTV}</math> is outputted from this pin. The output resistance of this pin is <math>25\Omega</math>. The same signal is also outputted from Det Select as a sync separation signal.</p>	

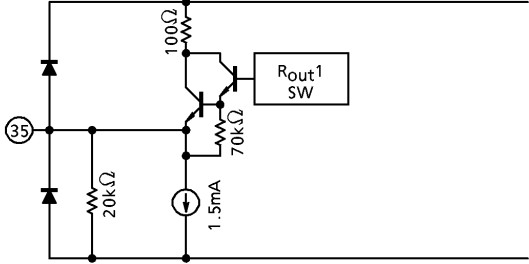
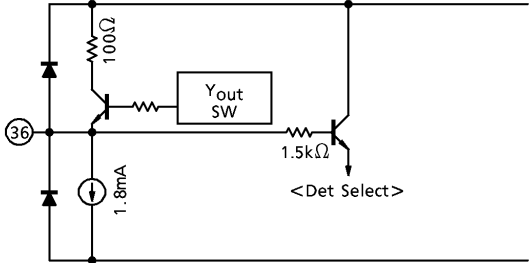
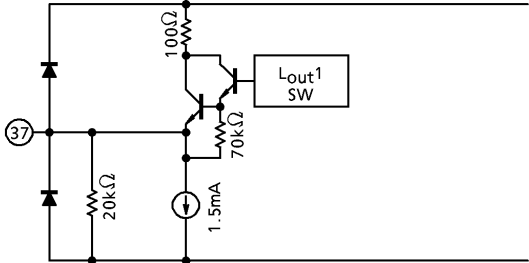
PIN No.	NAME	FUNCTION	INTERFACE
35	R <sub>out1</sub>	<p>This pin is for output the main channel right audio signal. The signal fed into R<sub>in</sub>V1, R<sub>in</sub>V2, R<sub>in</sub>S1, R<sub>in</sub>S2, or R<sub>in</sub>TV is outputted from this pin. The output resistance of this pin is 45Ω.</p> <p>Furthermore, the signal outputted from this pin is pulse-converted for use in self-diagnosis. The converted signal is outputted from Sync Out. This outputted can be muted independently of L<sub>out1</sub> by bus control.</p>	
36	Y <sub>out</sub>	<p>This pin is for output a luminance signal. The signal fed into Y<sub>in</sub>, Y/V<sub>in</sub>S1, Y/V<sub>in</sub>S2, V<sub>in</sub>V1, V<sub>in</sub>V2, or V<sub>in</sub>TV is outputted from this pin. The output resistance of this pin is 25Ω.</p> <p>The same signal is also outputted from Det Select as a sync separation signal.</p>	
37	L <sub>out1</sub>	<p>This pin is for output the main channel left audio signal. The signal fed into L<sub>in</sub>V1, L<sub>in</sub>V2, L<sub>in</sub>S1, L<sub>in</sub>S2, or L<sub>in</sub>TV is outputted from this pin. The output resistance of this pin is 45Ω.</p> <p>Furthermore, the signal outputted from this pin is pulse-converted for use in self-diagnosis. The converted signal is outputted from Sync Out. This output can be muted independently of R<sub>out1</sub> by bus control.</p>	

PIN No.	NAME	FUNCTION	INTERFACE
38	V <sub>out1</sub>	<p>This pin is for output the main channel composite video signal. The signal fed into V<sub>inTV</sub>, V<sub>inV1</sub>, V<sub>inV2</sub>, V<sub>inS1</sub>, V<sub>inS2</sub>, Y<sub>inS1</sub> + C<sub>inS1</sub>, or Y<sub>inS2</sub> + C<sub>inS2</sub> is outputted from this pin. The output resistance of this pin is 25Ω.</p> <p>The same signal is also outputted from Det Select as a sync separation signal.</p>	
39	R <sub>outTV</sub>	<p>This pin is for output only the signal that is forwarded from R<sub>inTV</sub>. The output resistance of this pin is 45Ω. This output can be muted in combination with L<sub>outTV</sub> by bus control.</p>	
40	L <sub>outTV</sub>	<p>This pin is for output only the signal that is forwarded from L<sub>inTV</sub>. The output resistance of this pin is 45Ω. This output can be muted in combination with R<sub>outTV</sub> by bus control.</p>	

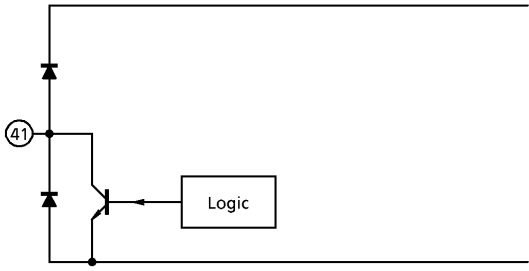
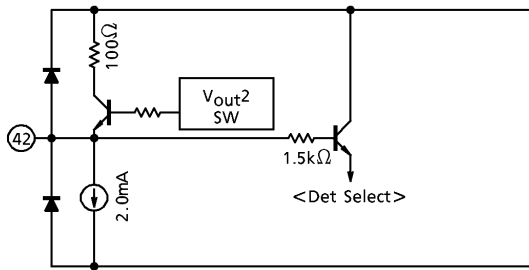
PIN No.	NAME	FUNCTION	INTERFACE
41	O5	This is a 1bit DAC output pin. This is an open-collector output. Make sure that the current flowing into this pin is 2.0mA or less.	
42	V <sub>out2</sub>	This pin is for output a sub-channel composite video signal. The signal fed into V <sub>inTV</sub> , V <sub>inV1</sub> , V <sub>inV2</sub> , V <sub>inS1</sub> , V <sub>inS2</sub> , Y <sub>inS1</sub> + C <sub>inS1</sub> , or Y <sub>inS2</sub> + C <sub>inS2</sub> is outputted from this pin. The output resistance of this pin is 25Ω. The same signal is also outputted from Det Select as a sync separation signal.	

**BUS DATA SPECIFICATIONS**

Data structure

(1) Write

S	Slave address (90H or 92H)	W (0)	A	Data 1	A	Data 2	A	Data 3	A	P
---	-------------------------------	----------	---	--------	---	--------	---	--------	---	---

(2) Read

S	Slave address (91H or 93H)	R (1)	A	Data 4	A	P
---	-------------------------------	----------	---	--------	---	---

\* Slave address is switched by the voltage applied to pin 27 (address). Switched to 90H when low (GND) ; switched to 92H when high (V<sub>CC</sub>) during write mode.

Contents of data

MODE	DATA No.	CONTENTS OF DATA							
		B07	B06	B05	B04	B03	B02	B01	B00
Write	Data 1 [F0H]	Audio mute				Forced TV Audio	/	YC output switching	
		LoutTV RoutTV	Lout2 Rout2	Rout1	Lout1			Yout	Cout
	Data 2 [1FH]	B17	B16	B15	B14	B13	B12	B11	B10
		Sync detection sensitivity switching	Sync output switching	Sync (diagnosis) detection switching			Input select (Main)		
		B27	B26	B25	B24	B23	B22	B21	B20
Data 3 [07H]	DAC output switching					Input select (Sub)			
	O5	O4	I/O3	I/O2	I/O1				
Read	Data 4	B37	B36	B35	B34	B33	B32	B31	B30
		ADC input discrimination					S input discrimination		Power- on reset
		I/O3	I/O2 Hi	I/O2 Low	I/O1 Hi	I/O1 Low	CinS1	CinS2	

(Note) Shown in [ ] are reset data.

(Note) The data contents marked by a slash (/) are an unused bit (data free).

Main Video select

MODE		OUTPUT SIGNAL $V_{out1}$	S INPUT DISCRIMINATION		BUS DATA		
INPUT	S/V		CS1	CS2	INPUT SELECT (MAIN)		
					B12	B11	B10
S1	V	$Y/V_{inS1}$	Low	*	0	0	0
	S	$Y/V_{inS1} + C_{inS1}$	Open				
	FV	$Y/V_{inS1}$					1
S2	V	$Y/V_{inS2}$	*	Low	0	1	0
	S	$Y/V_{inS2} + C_{inS2}$		Open			
	FV	$Y/V_{inS2}$					1
V1	V	$V_{inV1}$	*	*	1	0	1
V2	V	$V_{inV2}$	*	*	1	1	0
TV	V	$V_{inTV}$	*	*	1	1	1

Do not use [100] for the input select data.

Main L/R select

MODE	MAIN L/R OUTPUT SIGNAL		BUS DATA			
	$L_{out1}$	$R_{out1}$	FORCED TV VOICE	INPUT SELECT (MAIN)		
INPUT			B03	B12	B11	B10
S1	$L_{inS1}$	$R_{inS1}$	0	0	0	*
S2	$L_{inS2}$	$R_{inS2}$		0	1	*
V1	$L_{inV1}$	$R_{inV1}$		1	0	1
V2	$L_{inV2}$	$R_{inV2}$		1	1	0
TV	$L_{inTV}$	$R_{inTV}$		1	1	1
TV	$L_{inTV}$	$R_{inTV}$	1	*	*	*

Do not use [100] for the input select data.



Sub (PIP) Video Select

MODE		OUTPUT SIGNAL	S INPUT DISCRIMINATION		BUS DATA		
INPUT	S/V				INPUT SELECT (Sub)		
		$V_{out2}$			B22	B21	B20
S1	V	$Y/V_{inS1}$	Low	*	0	0	0
	S	$Y/V_{inS1} + C_{inS1}$	Open				
	FV	$Y/V_{inS1}$					1
S2	V	$Y/V_{inS2}$	*	Low	0	1	0
	S	$Y/V_{inS2} + C_{inS2}$		Open			
	FV	$Y/V_{inS2}$					1
V1	V	$V_{in1}$	*	*	1	1	1
V2	V	$V_{in2}$	*	*	1	1	0
TV	V	$V_{inTV}$	*	*	1	1	1

Do not use [100] for the input select data.

Sub L/R Select

MODE	SUB L/R OUTPUT SIGNAL		BUS DATA			
	$L_{out2}$	$R_{out2}$	FORCED TV VOICE	INPUT SELECT (SUB)		
INPUT	$L_{in2}$	$R_{in2}$	B03	B22	B21	B20
S1	$L_{inS1}$	$R_{inS1}$	0	0	0	*
S2	$L_{inS2}$	$R_{inS2}$		0	1	*
V1	$L_{inV1}$	$R_{inV1}$		1	0	1
V2	$L_{inV2}$	$R_{inV2}$		1	1	0
TV	$L_{inTV}$	$R_{inTV}$		1	1	1
TV	$L_{inTV}$	$R_{inTV}$	1	*	*	*

Do not use [100] for the input select data.

Y output select

MODE		Y OUTPUT SIGNAL	MAIN V SELECT MODE (SEE TABLE 2-2.)		BUS DATA Y OUTPUT SWITCHING
INPUT	THROUGH	$Y_{out}$			B01
S1	$Y_{in}$	$Y_{in}$	S1	V or FV	0
	V through	$Y/V_{in}S1$		S	1
	Y through	$Y/V_{in}S1$			*
S2	$Y_{in}$	$Y_{in}$	S2	V or FV	0
	V through	$Y/V_{in}S2$		S	1
	Y through	$Y/V_{in}S2$			*
V1	$Y_{in}$	$Y_{in}$	V1	V	0
	V through	$V_{in}V1$			1
V2	$Y_{in}$	$Y_{in}$	V2	V	0
	V through	$V_{in}V2$			1
TV	$Y_{in}$	$Y_{in}$	TV	V	0
	V through	$V_{in}TV$			1

C output select

MODE		Y OUTPUT SIGNAL	MAIN V SELECT MODE (SEE TABLE 2-2.)		BUS DATA C OUTPUT SWITCHING
INPUT	THROUGH	$C_{out}$			B00
S1	$C_{in}$	$C_{in}$	S1	V or FV	0
	V through	$Y/V_{in}S1$		S	1
	C through	$C_{in}S1$			*
S2	$C_{in}$	$C_{in}$	S2	V or FV	0
	V through	$Y/V_{in}S2$		S	1
	C through	$C_{in}S2$			*
V1	$C_{in}$	$C_{in}$	V1	V	0
	V through	$V_{in}V1$			1
V2	$C_{in}$	$C_{in}$	V2	V	0
	V through	$V_{in}V2$			1
TV	$C_{in}$	$C_{in}$	TV	V	0
	V through	$V_{in}TV$			1

Sync detection select

MODE		DETECTION SELECT	SYNC OUTPUT	BUS DATA			
				SYNC SWITCHING	SYNC DETECTION SWITCHING		
		DET SELECT	SYNC OUT	B16	B15	B14	B13
Video Input	TV	V <sub>in</sub> TV	Sync	0	0	1	1
	V1	V <sub>in</sub> V1				0	1
	V2	V <sub>in</sub> V2				1	0
	S1	Y/V <sub>in</sub> S1				0	0
Video Output	V <sub>out</sub> 1	V <sub>out</sub> 1	Sync	0	1	1	1
	V <sub>out</sub> 2	V <sub>out</sub> 2				0	1
	Y <sub>out</sub>	Y <sub>out</sub>				1	0
	C <sub>out</sub>	C <sub>out</sub>				0	0
Audio Output	R <sub>out</sub> 1	★	R <sub>out</sub> 1	1	*	1	1
	L <sub>out</sub> 1	★	L <sub>out</sub> 1			0	1
	R <sub>out</sub> 2	★	R <sub>out</sub> 2			1	0
	L <sub>out</sub> 2	★	L <sub>out</sub> 2			0	0

For Det Select marked by ★, the video input or video output corresponding to data B15, B14, and B13 is selected.

Sync detection sensitivity switching

MODE		BUS DATA
		DETECTION SENSITIVITY SWITCHING
		B17
Sensitivity	High	1
	Low	0

Audio mute

MODE		BUS DATA			
		AUDIO MUTE			
OUTPUT	MUTE	B07	B06	B05	B04
Lout1	off	*	*	*	0
	on				1
Rout1	off	*	*	0	*
	on			1	
Lout2 Rout2	off	*	0	*	*
	on		1		
LoutTV RoutTV	off	0	*	*	*
	on	1			

DAC output switching

MODE		BUS DATA				
		DAC OUTPUT SWITCHING				
OUTPUT	STATE	B27	B26	B25	B24	B23
I/O1	Open	*	*	*	*	0
	Low					1
I/O2	Open	*	*	*	0	*
	Low				1	
I/O3	Open	*	*	0	*	*
	Low			1		
O4	Open	*	0	*	*	*
	Low		1			
O5	Open	0	*	*	*	*
	Low	1				

Read mode

Power-on reset discrimination

MODE		BUS DATA	
		POWER-ON RESET	
		B30	
Reset	on	1	
	off	0	

S input discrimination

MODE		BUS DATA	
		S INPUT DISCRIMINATION	
INPUT	VOLTAGE	B32	B31
C <sub>in</sub> S2	High (Open)	*	1
	Low		0
C <sub>in</sub> S1	High (Open)	1	*
	Low	0	

ADC input discrimination

MODE		BUS DATA				
		ADC INPUT DISCRIMINATION				
INPUT	VOLTAGE	B37	B36	B35	B34	B33
I/O1	High	*	*	*	0	0
	Mid				1	0
	Low				0	1
	Bottom				1	1
I/O2	High	*	0	0	*	*
	Mid		1	0		
	Low		0	1		
	Bottom		1	1		
I/O3	High	0	*	*	*	*
	Low	1				

**OUTLINE OF I<sup>2</sup>C BUS CONTROL FORMAT**

The TA1218AN's bus control format conforms to the Philips I<sup>2</sup>C bus control format.

**(1) Start and stop conditions**

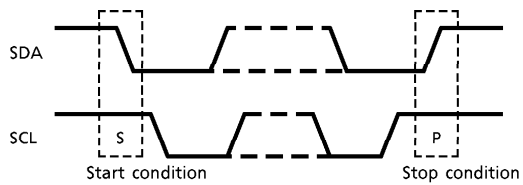

**(2) Bit transfer**

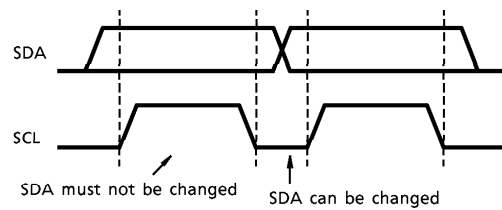

**(3) Acknowledgement**

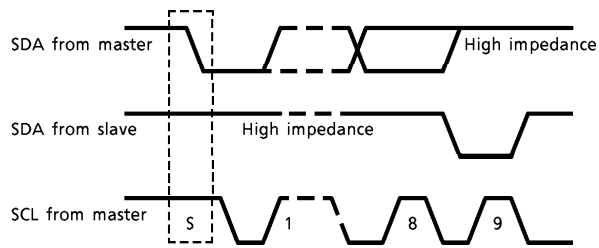

Purchase of TOSHIBA I<sup>2</sup>C components conveys a license under the Philips I<sup>2</sup>C Patent Rights to use these components in an I<sup>2</sup>C system, provided that the system conforms to the I<sup>2</sup>C Standard Specification as defined by Philips.

**MAXIMUM RATINGS**

CHARACTERISTIC	SYMBOL	RATING	UNIT
Supply Voltage	V <sub>CC</sub>	14	V
Power Dissipation	P <sub>D</sub> MAX	1800 (Note)	mW
Operating Temperature	T <sub>opr</sub>	-20~65	°C
Storage Temperature	T <sub>stg</sub>	-55~150	°C

(Note) When using the device at temperatures above Ta = 25°C, reduce the rated power dissipation by 14.4mW per degree of centigrade. (See the diagram below.)

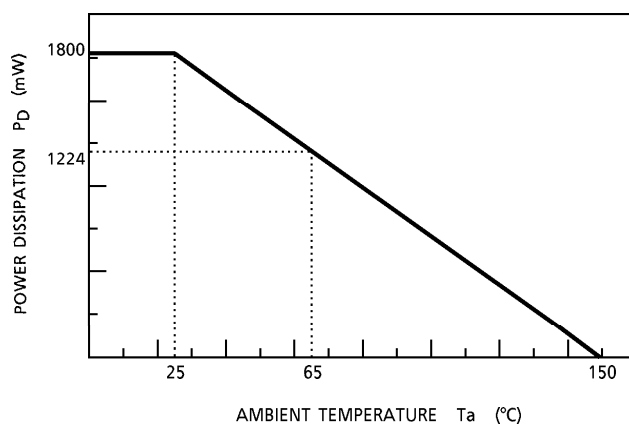

**RECOMMENDED OPERATING CONDITIONS**

CHARACTERISTIC	PIN No.	MIN.	TYP.	MAX.	UNIT	REMARK
Supply Voltage	33	8.1	9.0	9.9	V	—
Composite Signal Input Amplitude	7, 10, 12, 16, 28	—	1.0	—	V <sub>p-p</sub>	100IRE
Y Input Amplitude	12, 16	—	1.0	—	V <sub>p-p</sub>	100IRE
Comb Y Input Amplitude	30	—	2.0	—	V <sub>p-p</sub>	—
Chroma Input Amplitude	14, 18	—	286	—	mV <sub>p-p</sub>	Burst
Comb Chroma Input Amplitude	32	—	572	—	mV <sub>p-p</sub>	Burst
Audio Input Amplitude	5, 6, 8, 9, 11, 13, 15, 17, 29, 31	—	—	6.0	V <sub>p-p</sub>	—

**ELECTRICAL CHARACTERISTICS**(Referenced to  $V_{CC}=9V$  at  $T_a = 25^\circ C$  unless otherwise specified)

Current consumption

PIN No.	PIN NAME	SYMBOL	TEST CIR-CUIT	MIN.	TYP.	MAX.	UNIT
33	$V_{CC}$	$I_{CC}$	—	30	47	64	mA

Pin voltage

PIN No.	PIN NAME	SYMBOL	TEST CIR-CUIT	MIN.	TYP.	MAX.	UNIT
1	$L_{out2}$	V1	—	3.7	4.0	4.3	V
2	$R_{out2}$	V2	—	3.7	4.0	4.3	V
3	Det in	V3	—	6.3	6.6	6.9	V
4	Det Select	V4	—	3.4	3.7	4.0	V
5	$L_{inTV}$	V5	—	5.0	5.2	5.4	V
6	$R_{inTV}$	V6	—	5.0	5.2	5.4	V
7	$V_{inTV}$	V7	—	5.0	5.2	5.4	V
8	$L_{inV1}$	V8	—	5.0	5.2	5.4	V
9	$R_{inV1}$	V9	—	5.0	5.2	5.4	V
10	$V_{inV1}$	V10	—	5.0	5.2	5.4	V
11	$L_{inS1}$	V11	—	5.0	5.2	5.4	V
12	$Y/V_{inS1}$	V12	—	5.0	5.2	5.4	V
13	$R_{inS1}$	V13	—	5.0	5.2	5.4	V
14	$C_{inS1}$	V14	—	5.0	5.2	5.4	V
15	$L_{inS2}$	V15	—	5.0	5.2	5.4	V
16	$Y/V_{inS2}$	V16	—	5.0	5.2	5.4	V
17	$R_{inS2}$	V17	—	5.0	5.2	5.4	V
18	$C_{inS2}$	V18	—	5.0	5.2	5.4	V
23	GND	V23	—	—	0	—	V
28	$V_{inV2}$	V28	—	5.0	5.2	5.4	V
29	$L_{inV2}$	V29	—	5.0	5.2	5.4	V
30	$Y_{in}$	V30	—	5.0	5.2	5.4	V
31	$R_{inV2}$	V31	—	5.0	5.2	5.4	V
32	$C_{in}$	V32	—	5.0	5.2	5.4	V
33	$V_{CC}$	V33	—	—	9.0	—	V
34	$C_{out}$	V34	—	3.5	3.8	4.1	V
35	$R_{out1}$	V35	—	3.7	4.0	4.3	V
36	$Y_{out}$	V36	—	3.5	3.8	4.1	V
37	$L_{out1}$	V37	—	3.7	4.0	4.3	V
38	$V_{out1}$	V38	—	4.1	4.4	4.7	V
39	$R_{outTV}$	V39	—	3.7	4.0	4.3	V
40	$L_{outTV}$	V40	—	3.7	4.0	4.3	V
42	$V_{out2}$	V42	—	4.1	4.4	4.7	V



## DC Characteristics

CHARACTERISTIC	MEASURED PIN	SYMBOL	TEST CIRCUIT	MIN.	TYP.	MAX.	UNIT	REMARK
Input Pin Input Resistance	Det in	R3	—	10	18	30	k $\Omega$	Measure a change $\Delta I$ in the current flowing into each pin when the voltage is raised by 0.5V. Then calculate the input resistance value R. $R = 0.5V / \Delta I$ [ $\Omega$ ]
	V <sub>inTV</sub>	R7	—	20	30	40	k $\Omega$	
	V <sub>inV1</sub>	R10	—	20	30	40	k $\Omega$	
	V <sub>inV2</sub>	R28	—	20	30	40	k $\Omega$	
	Y/V <sub>inS1</sub>	R12	—	20	30	40	k $\Omega$	
	Y/V <sub>inS2</sub>	R16	—	20	30	40	k $\Omega$	
	C <sub>inS1</sub>	R14	—	20	30	40	k $\Omega$	
	C <sub>inS2</sub>	R18	—	20	30	40	k $\Omega$	
	Y <sub>in</sub>	R30	—	40	60	80	k $\Omega$	
	C <sub>in</sub>	R32	—	40	60	80	k $\Omega$	
	L <sub>inTV</sub>	R5	—	49	70	100	k $\Omega$	
	R <sub>inTV</sub>	R6	—	49	70	100	k $\Omega$	
	L <sub>inV1</sub>	R8	—	49	70	100	k $\Omega$	
	R <sub>inV1</sub>	R9	—	49	70	100	k $\Omega$	
	L <sub>inV2</sub>	R29	—	49	70	100	k $\Omega$	
	R <sub>inV2</sub>	R31	—	49	70	100	k $\Omega$	
	L <sub>inS1</sub>	R11	—	49	70	100	k $\Omega$	
	R <sub>inS1</sub>	R13	—	49	70	100	k $\Omega$	
L <sub>inS2</sub>	R15	—	49	70	100	k $\Omega$		
R <sub>inS2</sub>	R17	—	49	70	100	k $\Omega$		
Output Pin Output Resistance	Det Select	R4	—	17	35	53	$\Omega$	Measure a voltage change $\Delta V$ on each pin when a current of 100 $\mu$ A flows into the pin. Then calculate the output resistance value R. $R = \Delta V / 100\mu A$ [ $\Omega$ ]
	V <sub>out1</sub>	R38	—	13	25	50	$\Omega$	
	V <sub>out2</sub>	R42	—	13	25	50	$\Omega$	
	Y <sub>out</sub>	R36	—	13	25	50	$\Omega$	
	C <sub>out</sub>	R34	—	13	25	50	$\Omega$	
	L <sub>outTV</sub>	R40	—	20	45	90	$\Omega$	
	R <sub>outTV</sub>	R39	—	20	45	90	$\Omega$	
	L <sub>out1</sub>	R37	—	20	45	90	$\Omega$	
	R <sub>out1</sub>	R35	—	20	45	90	$\Omega$	
	L <sub>out2</sub>	R1	—	20	45	90	$\Omega$	
R <sub>out2</sub>	R2	—	20	45	90	$\Omega$		
S Mode Discrimination Voltage	C <sub>inS1</sub>	VthC1	—	1.75	2.25	2.75	V	Voltage on pin 14 at which data B31 changes.
	C <sub>inS2</sub>	VthC2	—	1.75	2.25	2.75	V	Voltage on pin 18 at which data B32 changes.
External Mute ON Voltage	C <sub>in</sub>	VthM	—	1.75	2.25	2.75	V	Voltage on pin 32 at which voice is muted.

CHARACTERISTIC	MEASURED PIN	SYMBOL	TEST CIR-CUIT	MIN.	TYP.	MAX.	UNIT	REMARK
Address Switching Voltage	address	VthA	—	1.75	2.25	2.75	V	Voltage on pin 27 at which the slave address changes.
ADC Input Discrimination Voltage	I/O1	Vth1L	—	0.55	0.75	0.95	V	Low-Bottom threshold level of I/O1 input (pin 19).
	I/O1	Vth1M	—	2.5	3.0	3.5	V	Mid-Low threshold level of I/O1 input (pin 19).
	I/O1	Vth1H	—	7.5	8.0	8.5	V	High-Mid threshold level of I/O1 input (pin 19).
	I/O2	Vth2L	—	0.55	0.75	0.95	V	Low-Bottom threshold level of I/O2 input (pin 20).
	I/O2	Vth2M	—	2.5	3.0	3.5	V	Mid-Low threshold level of I/O2 input (pin 20).
	I/O2	Vth2H	—	7.5	8.0	8.5	V	High-Mid threshold level of I/O1 input (pin 20).
	I/O3	Vth3	—	1.75	2.25	2.75	V	High-Low threshold level of I/O1 input (pin 21).

AC Characteristics

CHARACTERISTIC	SELECT MODE	SYMBOL	TEST CIR-CUIT	MIN.	TYP.	MAX.	UNIT	TEST METHOD
V <sub>out1</sub> Input Dynamic Range	V <sub>in</sub> TV	VDR7V1	—	1.5	2.0	—	V <sub>p-p</sub>	(1) Apply a 15kHz sine wave to each input pin. (2) In each select mode, measure an input amplitude at which the output waveform on pin 38 begins to be distorted.
	V <sub>in</sub> V1	VDR10V1	—	1.5	2.0	—	V <sub>p-p</sub>	
	V <sub>in</sub> V2	VDR28V1	—	1.5	2.0	—	V <sub>p-p</sub>	
	Y/V <sub>in</sub> S1	VDR12V1	—	1.5	2.0	—	V <sub>p-p</sub>	
	C <sub>in</sub> S1	VDR14V1	—	1.5	2.0	—	V <sub>p-p</sub>	
	Y/V <sub>in</sub> S2	VDR16V1	—	1.5	2.0	—	V <sub>p-p</sub>	
	C <sub>in</sub> S2	VDR18V1	—	1.5	2.0	—	V <sub>p-p</sub>	
V <sub>out1</sub> Gain	V <sub>in</sub> TV	G7V1	—	5.5	6.0	6.5	dB	(1) Apply a 15kHz, 1.0V <sub>p-p</sub> sine wave to each input pin. (2) In each select mode, find the gain between input and output.
	V <sub>in</sub> V1	G10V1	—	5.5	6.0	6.5	dB	
	V <sub>in</sub> V2	G28V1	—	5.5	6.0	6.5	dB	
	Y/V <sub>in</sub> S1	G12V1	—	5.5	6.0	6.5	dB	
	C <sub>in</sub> S1	G14V1	—	5.5	6.0	6.5	dB	
	Y/V <sub>in</sub> S2	G16V1	—	5.5	6.0	6.5	dB	
	C <sub>in</sub> S2	G18V1	—	5.5	6.0	6.5	dB	
V <sub>out1</sub> Frequency Response	V <sub>in</sub> TV	F7V1	—	10	—	—	MHz	(1) Apply a 1.0V <sub>p-p</sub> sine wave to each input pin. (2) In each select mode, measure a frequency at which the output amplitude on pin 38 is 3dB down from the 15kHz applied level.
	V <sub>in</sub> V1	F10V1	—	10	—	—	MHz	
	V <sub>in</sub> V2	F28V1	—	10	—	—	MHz	
	Y/V <sub>in</sub> S1	F12V1	—	10	—	—	MHz	
	C <sub>in</sub> S1	F14V1	—	10	—	—	MHz	
	Y/V <sub>in</sub> S2	F16V1	—	10	—	—	MHz	
	C <sub>in</sub> S2	F18V1	—	10	—	—	MHz	
V <sub>out1</sub> Crosstalk	V <sub>in</sub> TV	CT7V1	—	55	60	—	dB	(1) Apply a 3.58MHz, 1.0V <sub>p-p</sub> sine wave to each input pin. (2) In each select mode, compare signal output from the selected pin with leakage components from nonselected pins to find a crosstalk.
	V <sub>in</sub> V1	CT10V1	—	55	60	—	dB	
	V <sub>in</sub> V2	CT28V1	—	55	60	—	dB	
	Y/V <sub>in</sub> S1	CT12V1	—	55	60	—	dB	
	C <sub>in</sub> S1	CT14V1	—	55	60	—	dB	
	Y/V <sub>in</sub> S2	CT16V1	—	55	60	—	dB	
	C <sub>in</sub> S2	CT18V1	—	55	60	—	dB	
V <sub>out2</sub> Input Dynamic Range	V <sub>in</sub> TV	VDR7V2	—	1.5	2.0	—	V <sub>p-p</sub>	(1) Apply a 15kHz sine wave to each input pin. (2) In each select mode, measure an input amplitude at which the output waveform on pin 42 begins to be distorted.
	V <sub>in</sub> V1	VDR10V2	—	1.5	2.0	—	V <sub>p-p</sub>	
	V <sub>in</sub> V2	VDR28V2	—	1.5	2.0	—	V <sub>p-p</sub>	
	Y/V <sub>in</sub> S1	VDR12V2	—	1.5	2.0	—	V <sub>p-p</sub>	
	C <sub>in</sub> S1	VDR14V2	—	1.5	2.0	—	V <sub>p-p</sub>	
	Y/V <sub>in</sub> S2	VDR16V2	—	1.5	2.0	—	V <sub>p-p</sub>	
	C <sub>in</sub> S2	VDR18V2	—	1.5	2.0	—	V <sub>p-p</sub>	

CHARACTERISTIC	SELECT MODE	SYMBOL	TEST CIR-CUIT	MIN.	TYP.	MAX.	UNIT	TEST METHOD
V <sub>out2</sub> Gain	V <sub>inTV</sub>	G7V2	—	5.5	6.0	6.5	dB	(1) Apply a 15kHz, 1.0V <sub>p-p</sub> sine wave to each input pin. (2) In each select mode, find the gain between input and output.
	V <sub>inV1</sub>	G10V2	—	5.5	6.0	6.5	dB	
	V <sub>inV2</sub>	G28V2	—	5.5	6.0	6.5	dB	
	Y/V <sub>inS1</sub>	G12V2	—	5.5	6.0	6.5	dB	
	C <sub>inS1</sub>	G14V2	—	5.5	6.0	6.5	dB	
	Y/V <sub>inS2</sub>	G16V2	—	5.5	6.0	6.5	dB	
	C <sub>inS2</sub>	G18V2	—	5.5	6.0	6.5	dB	
V <sub>out2</sub> Frequency Response	V <sub>inTV</sub>	F7V2	—	10	—	—	MHz	(1) Apply a 1.0V <sub>p-p</sub> sine wave to each input pin. (2) In each select mode, measure a frequency at which the output amplitude on pin 42 is 3dB down from the 15kHz applied level.
	V <sub>inV1</sub>	F10V2	—	10	—	—	MHz	
	V <sub>inV2</sub>	F28V2	—	10	—	—	MHz	
	Y/V <sub>inS1</sub>	F12V2	—	10	—	—	MHz	
	C <sub>inS1</sub>	F14V2	—	10	—	—	MHz	
	Y/V <sub>inS2</sub>	F16V2	—	10	—	—	MHz	
	C <sub>inS2</sub>	F18V2	—	10	—	—	MHz	
V <sub>out2</sub> Crosstalk	V <sub>inTV</sub>	CT7V2	—	55	60	—	dB	(1) Apply a 3.58MHz, 1.0V <sub>p-p</sub> sine wave to each input pin. (2) In each select mode, compare signal output from the selected pin with leakage components from nonselected pins to find a crosstalk.
	V <sub>inV1</sub>	CT10V2	—	55	60	—	dB	
	V <sub>inV2</sub>	CT28V2	—	55	60	—	dB	
	Y/V <sub>inS1</sub>	CT12V2	—	55	60	—	dB	
	C <sub>inS1</sub>	CT14V2	—	55	60	—	dB	
	Y/V <sub>inS2</sub>	CT16V2	—	55	60	—	dB	
	C <sub>inS2</sub>	CT18V2	—	55	60	—	dB	
Y <sub>out</sub> Input Dynamic Range	V <sub>inTV</sub>	VDR7Y	—	1.5	2.0	—	V <sub>p-p</sub>	(1) Apply a 15kHz sine wave to each input pin. (2) In each select mode, measure an input amplitude at which the output waveform on pin 36 begins to be distorted.
	V <sub>inV1</sub>	VDR10Y	—	1.5	2.0	—	V <sub>p-p</sub>	
	V <sub>inV2</sub>	VDR28Y	—	1.5	2.0	—	V <sub>p-p</sub>	
	Y/V <sub>inS1</sub>	VDR12Y	—	1.5	2.0	—	V <sub>p-p</sub>	
	Y/V <sub>inS2</sub>	VDR16Y	—	1.5	2.0	—	V <sub>p-p</sub>	
	Y <sub>in</sub>	VDR30Y	—	5.0	5.5	—	V <sub>p-p</sub>	
Y <sub>out</sub> Gain	V <sub>inTV</sub>	G7Y	—	5.5	6.0	6.5	dB	(1) Apply a 15kHz, 1.0V <sub>p-p</sub> sine wave to each input pin. (2) In each select mode, find the gain between input and output.
	V <sub>inV1</sub>	G10Y	—	5.5	6.0	6.5	dB	
	V <sub>inV2</sub>	G28Y	—	5.5	6.0	6.5	dB	
	Y/V <sub>inS1</sub>	G12Y	—	5.5	6.0	6.5	dB	
	Y/V <sub>inS2</sub>	G16Y	—	5.5	6.0	6.5	dB	
	Y <sub>in</sub>	G30Y	—	-0.5	0	0.5	dB	

CHARACTERISTIC	SELECT MODE	SYMBOL	TEST CIR-CUIT	MIN.	TYP.	MAX.	UNIT	TEST METHOD
Y <sub>out</sub> Frequency Response	V <sub>in</sub> TV	F7Y	—	10	—	—	MHz	(1) Apply a 1.0V <sub>p-p</sub> sine wave to each input pin. (2) In each select mode, measure a frequency at which the output amplitude on pin 36 is 3dB down from the 15kHz applied level.
	V <sub>in</sub> V1	F10Y	—	10	—	—	MHz	
	V <sub>in</sub> V2	F28Y	—	10	—	—	MHz	
	Y/V <sub>in</sub> S1	F12Y	—	10	—	—	MHz	
	Y/V <sub>in</sub> S2	F16Y	—	10	—	—	MHz	
	Y <sub>in</sub>	F30Y	—	10	—	—	MHz	
Y <sub>out</sub> Crosstalk	V <sub>in</sub> TV	CT7Y	—	55	60	—	dB	(1) Apply a 3.58MHz, 1.0V <sub>p-p</sub> sine wave to each input pin. (2) In each select mode, compare signal output from the selected pin with leakage components from nonselected pins to find a crosstalk.
	V <sub>in</sub> V1	CT10Y	—	55	60	—	dB	
	V <sub>in</sub> V2	CT28Y	—	55	60	—	dB	
	Y/V <sub>in</sub> S1	CT12Y	—	55	60	—	dB	
	Y/V <sub>in</sub> S2	CT16Y	—	55	60	—	dB	
	Y <sub>in</sub>	CT30Y	—	55	60	—	dB	
C <sub>out</sub> Input Dynamic Range	V <sub>in</sub> TV	VDR7C	—	1.5	2.0	—	V <sub>p-p</sub>	(1) Apply a 15kHz sine wave to each input pin. (2) In each select mode, measure an input amplitude at which the output waveform on pin 34 begins to be distorted.
	V <sub>in</sub> V1	VDR10C	—	1.5	2.0	—	V <sub>p-p</sub>	
	V <sub>in</sub> V2	VDR28C	—	1.5	2.0	—	V <sub>p-p</sub>	
	Y/V <sub>in</sub> S1	VDR12C	—	1.5	2.0	—	V <sub>p-p</sub>	
	C <sub>in</sub> S1	VDR14C	—	1.5	2.0	—	V <sub>p-p</sub>	
	Y/V <sub>in</sub> S2	VDR16C	—	1.5	2.0	—	V <sub>p-p</sub>	
	C <sub>in</sub> S2	VDR18C	—	1.5	2.0	—	V <sub>p-p</sub>	
	C <sub>in</sub>	VDR32C	—	5.0	5.5	—	V <sub>p-p</sub>	
C <sub>out</sub> Gain	V <sub>in</sub> TV	G7C	—	5.5	6.0	6.5	dB	(1) Apply a 15kHz, 1.0V <sub>p-p</sub> sine wave to each input pin. (2) In each select mode, find the gain between input and output.
	V <sub>in</sub> V1	G10C	—	5.5	6.0	6.5	dB	
	V <sub>in</sub> V2	G28C	—	5.5	6.0	6.5	dB	
	Y/V <sub>in</sub> S1	G12C	—	5.5	6.0	6.5	dB	
	C <sub>in</sub> S1	G14C	—	5.5	6.0	6.5	dB	
	Y/V <sub>in</sub> S2	G16C	—	5.5	6.0	6.5	dB	
	C <sub>in</sub> S2	G18C	—	5.5	6.0	6.5	dB	
	C <sub>in</sub>	G32C	—	-0.5	0	0.5	dB	

CHARACTERISTIC	SELECT MODE	SYMBOL	TEST CIR-CUIT	MIN.	TYP.	MAX.	UNIT	TEST METHOD
C <sub>out</sub> Frequency Response	V <sub>in</sub> TV	F7C	—	10	—	—	MHz	(1) Apply a 1.0V <sub>p-p</sub> sine wave to each input pin. (2) In each select mode, measure a frequency at which the output amplitude on pin 34 is 3dB down from the 15kHz applied level.
	V <sub>in</sub> V1	F10C	—	10	—	—	MHz	
	V <sub>in</sub> V2	F28C	—	10	—	—	MHz	
	Y/V <sub>in</sub> S1	F12C	—	10	—	—	MHz	
	C <sub>in</sub> S1	F14C	—	10	—	—	MHz	
	Y/V <sub>in</sub> S2	F16C	—	10	—	—	MHz	
	C <sub>in</sub> S2	F18C	—	10	—	—	MHz	
	C <sub>in</sub>	F32C	—	10	—	—	MHz	
C <sub>out</sub> Crosstalk	V <sub>in</sub> TV	CT7C	—	55	60	—	dB	(1) Apply a 3.58MHz, 1.0V <sub>p-p</sub> sine wave to each input pin. (2) In each select mode, compare signal output from the selected pin with leakage components from nonselected pins to find a crosstalk.
	V <sub>in</sub> V1	CT10C	—	55	60	—	dB	
	V <sub>in</sub> V2	CT28C	—	55	60	—	dB	
	Y/V <sub>in</sub> S1	CT12C	—	55	60	—	dB	
	C <sub>in</sub> S1	CT14C	—	55	60	—	dB	
	Y/V <sub>in</sub> S2	CT16C	—	55	60	—	dB	
	C <sub>in</sub> S2	CT18C	—	55	60	—	dB	
	C <sub>in</sub>	CT32C	—	55	60	—	dB	
Det Select Input Dynamic Range	V <sub>in</sub> TV	VDR7D	—	5.0	5.5	—	V	(1) Apply a 15kHz sine wave to each input pin. (2) In each select mode, measure an input amplitude at which the output waveform on pin 4 begins to be distorted.
	V <sub>in</sub> V1	VDR10D	—	5.0	5.5	—	V	
	V <sub>in</sub> V2	VDR28D	—	5.0	5.5	—	V	
	Y/V <sub>in</sub> S1	VDR12D	—	5.0	5.5	—	V	
	V <sub>out</sub> 1	VDR38D	—	1.5	2.0	—	V	
	V <sub>out</sub> 2	VDR42D	—	1.5	2.0	—	V	
	Y <sub>out</sub>	VDR36D	—	1.2	1.8	—	V	
	C <sub>out</sub>	VDR34D	—	1.2	1.8	—	V	
Det Select Gain	V <sub>in</sub> TV	G7D	—	-0.5	0	0.5	dB	(1) Apply a 15kHz, 1.0V <sub>p-p</sub> sine wave to each input pin. (2) In each select mode, find the gain between input and output.
	V <sub>in</sub> V1	G10D	—	-0.5	0	0.5	dB	
	V <sub>in</sub> V2	G28D	—	-0.5	0	0.5	dB	
	Y/V <sub>in</sub> S1	G12D	—	-0.5	0	0.5	dB	
	V <sub>out</sub> 1	G38D	—	-0.1	0	0.1	dB	
	V <sub>out</sub> 2	G42D	—	-0.1	0	0.1	dB	
	Y <sub>out</sub>	G36D	—	-0.1	0	0.1	dB	
	C <sub>out</sub>	G34D	—	-0.1	0	0.1	dB	

CHARACTERISTIC	SELECT MODE	SYMBOL	TEST CIRCUIT	MIN.	TYP.	MAX.	UNIT	TEST METHOD
L <sub>out1</sub> Input Dynamic Range	L <sub>in</sub> TV	VDR5L1	—	6.0	6.5	—	V <sub>p-p</sub>	(1) Apply a 1kHz sine wave to each input pin. (2) In each select mode, measure an input amplitude at which the output waveform on pin 37 begins to be distorted.
	L <sub>in</sub> V1	VDR8L1	—	6.0	6.5	—	V <sub>p-p</sub>	
	L <sub>in</sub> V2	VDR29L1	—	6.0	6.5	—	V <sub>p-p</sub>	
	L <sub>in</sub> S1	VDR11L1	—	6.0	6.5	—	V <sub>p-p</sub>	
	L <sub>in</sub> S2	VDR15L1	—	6.0	6.5	—	V <sub>p-p</sub>	
L <sub>out1</sub> Gain	L <sub>in</sub> TV	G5L1	—	-0.5	0	0.5	dB	(1) Apply a 1kHz, 1.0V <sub>p-p</sub> sine wave to each input pin. (2) In each select mode, find the gain between input and output.
	L <sub>in</sub> V1	G8L1	—	-0.5	0	0.5	dB	
	L <sub>in</sub> V2	G29L1	—	-0.5	0	0.5	dB	
	L <sub>in</sub> S1	G11L1	—	-0.5	0	0.5	dB	
	L <sub>in</sub> S2	G15L1	—	-0.5	0	0.5	dB	
L <sub>out1</sub> Frequency Response	L <sub>in</sub> TV	F5L1	—	0.1	2.0	—	MHz	(1) Apply a 1.0V <sub>p-p</sub> sine wave to each input pin. (2) In each select mode, measure a frequency at which the output amplitude on pin 37 is 3dB down from the 1 kHz applied level.
	L <sub>in</sub> V1	F8L1	—	0.1	2.0	—	MHz	
	L <sub>in</sub> V2	F29L1	—	0.1	2.0	—	MHz	
	L <sub>in</sub> S1	F11L1	—	0.1	2.0	—	MHz	
	L <sub>in</sub> S2	F15L1	—	0.1	2.0	—	MHz	
L <sub>out1</sub> Crosstalk	L <sub>in</sub> TV	CT5L1	—	70	100	—	dB	(1) Apply a 1kHz, 1.0V <sub>p-p</sub> sine wave to each input pin. (2) In each select mode, compare signal output from the selected pin with leakage components from nonselected pins to find a crosstalk.
	L <sub>in</sub> V1	CT8L1	—	70	100	—	dB	
	L <sub>in</sub> V2	CT29L1	—	70	100	—	dB	
	L <sub>in</sub> S1	CT11L1	—	70	100	—	dB	
	L <sub>in</sub> S2	CT15L1	—	70	100	—	dB	
L <sub>out1</sub> Mute Attenuation	L <sub>in</sub> TV	M5L1	—	70	100	—	dB	(1) Apply a 1kHz, 1.0V <sub>p-p</sub> sine wave to each input pin. (2) In each select mode, compare the output amplitudes on pin 37 when mute is turned on and turned off to find mute attenuation.
	L <sub>in</sub> V1	M8L1	—	70	100	—	dB	
	L <sub>in</sub> V2	M29L1	—	70	100	—	dB	
	L <sub>in</sub> S1	M11L1	—	70	100	—	dB	
	L <sub>in</sub> S2	M15L1	—	70	100	—	dB	

CHARACTERISTIC	SELECT MODE	SYMBOL	TEST CIR-CUIT	MIN.	TYP.	MAX.	UNIT	TEST METHOD
$R_{out1}$ Input Dynamic Range	$R_{inTV}$	VDR6R1	—	6.0	6.5	—	$V_{p-p}$	(1) Apply a 1kHz sine wave to each input pin. (2) In each select mode, measure an input amplitude at which the output waveform on pin 35 begins to be distorted.
	$R_{inV1}$	VDR9R1	—	6.0	6.5	—	$V_{p-p}$	
	$R_{inV2}$	VDR31R1	—	6.0	6.5	—	$V_{p-p}$	
	$R_{inS1}$	VDR13R1	—	6.0	6.5	—	$V_{p-p}$	
	$R_{inS2}$	VDR17R1	—	6.0	6.5	—	$V_{p-p}$	
$R_{out1}$ Gain	$R_{inTV}$	G6R1	—	-0.5	0	0.5	dB	(1) Apply a 1kHz, 1.0 $V_{p-p}$ sine wave to each input pin. (2) In each select mode, find the gain between input and output.
	$R_{inV1}$	G9R1	—	-0.5	0	0.5	dB	
	$R_{inV2}$	G31R1	—	-0.5	0	0.5	dB	
	$R_{inS1}$	G13R1	—	-0.5	0	0.5	dB	
	$R_{inS2}$	G17R1	—	-0.5	0	0.5	dB	
$R_{out1}$ Frequency Response	$R_{inTV}$	F6R1	—	0.1	2.0	—	MHz	(1) Apply a 1.0 $V_{p-p}$ sine wave to each input pin. (2) In each select mode, measure a frequency at which the output amplitude on pin 35 is 3dB down from the 1kHz applied level.
	$R_{inV1}$	F9R1	—	0.1	2.0	—	MHz	
	$R_{inV2}$	F31R1	—	0.1	2.0	—	MHz	
	$R_{inS1}$	F13R1	—	0.1	2.0	—	MHz	
	$R_{inS2}$	F17R1	—	0.1	2.0	—	MHz	
$R_{out1}$ Crosstalk	$R_{inTV}$	CT6R1	—	70	100	—	dB	(1) Apply a 1kHz, 1.0 $V_{p-p}$ sine wave to each input pin. (2) In each select mode, compare signal output from the selected pin with leakage components from nonselected pins to find a crosstalk.
	$R_{inV1}$	CT9R1	—	70	100	—	dB	
	$R_{inV2}$	CT31R1	—	70	100	—	dB	
	$R_{inS1}$	CT13R1	—	70	100	—	dB	
	$R_{inS2}$	CT17R1	—	70	100	—	dB	
$R_{out1}$ Mute Attenuation	$R_{inTV}$	M6R1	—	70	100	—	dB	(1) Apply a 1kHz, 1.0 $V_{p-p}$ sine wave to each input pin. (2) In each select mode, compare the output amplitudes on pin 35 when mute is turned on and turned off to find mute attenuation.
	$R_{inV1}$	M9R1	—	70	100	—	dB	
	$R_{inV2}$	M31R1	—	70	100	—	dB	
	$R_{inS1}$	M13R1	—	70	100	—	dB	
	$R_{inS2}$	M17R1	—	70	100	—	dB	



CHARACTERISTIC	SELECT MODE	SYMBOL	TEST CIRCUIT	MIN.	TYP.	MAX.	UNIT	TEST METHOD
$L_{out2}$ Input Dynamic Range	$L_{inTV}$	VDR5L2	—	6.0	6.5	—	$V_{p-p}$	(1) Apply a 1kHz sine wave to each input pin. (2) In each select mode, measure an input amplitude at which the output waveform on pin 1 begins to be distorted.
	$L_{inV1}$	VDR8L2	—	6.0	6.5	—	$V_{p-p}$	
	$L_{inV2}$	VDR29L2	—	6.0	6.5	—	$V_{p-p}$	
	$L_{inS1}$	VDR11L2	—	6.0	6.5	—	$V_{p-p}$	
	$L_{inS2}$	VDR15L2	—	6.0	6.5	—	$V_{p-p}$	
$L_{out2}$ Gain	$L_{inTV}$	G5L2	—	-0.5	0	0.5	dB	(1) Apply a 1kHz, 1.0 $V_{p-p}$ sine wave to each input pin. (2) In each select mode, find the gain between input and output.
	$L_{inV1}$	G8L2	—	-0.5	0	0.5	dB	
	$L_{inV2}$	G29L2	—	-0.5	0	0.5	dB	
	$L_{inS1}$	G11L2	—	-0.5	0	0.5	dB	
	$L_{inS2}$	G15L2	—	-0.5	0	0.5	dB	
$L_{out2}$ Frequency Response	$L_{inTV}$	F5L2	—	0.1	2.0	—	MHz	(1) Apply a 1.0 $V_{p-p}$ sine wave to each input pin. (2) In each select mode, measure a frequency at which the output amplitude on pin 1 is 3dB down from the 1kHz applied level.
	$L_{inV1}$	F8L2	—	0.1	2.0	—	MHz	
	$L_{inV2}$	F29L2	—	0.1	2.0	—	MHz	
	$L_{inS1}$	F11L2	—	0.1	2.0	—	MHz	
	$L_{inS2}$	F15L2	—	0.1	2.0	—	MHz	
$L_{out2}$ Crosstalk	$L_{inTV}$	CT5L2	—	70	100	—	dB	(1) Apply a 1kHz, 1.0 $V_{p-p}$ sine wave to each input pin. (2) In each select mode, compare signal output from the selected pin with leakage components from nonselected pins to find a crosstalk.
	$L_{inV1}$	CT8L2	—	70	100	—	dB	
	$L_{inV2}$	CT29L2	—	70	100	—	dB	
	$L_{inS1}$	CT11L2	—	70	100	—	dB	
	$L_{inS2}$	CT15L2	—	70	100	—	dB	
$L_{out2}$ Mute Attenuation	$L_{inTV}$	M5L2	—	70	100	—	dB	(1) Apply a 1kHz, 1.0 $V_{p-p}$ sine wave to each input pin. (2) In each select mode, compare the output amplitudes on pin 1 when mute is turned on and turned off to find mute attenuation.
	$L_{inV1}$	M8L2	—	70	100	—	dB	
	$L_{inV2}$	M29L2	—	70	100	—	dB	
	$L_{inS1}$	M11L2	—	70	100	—	dB	
	$L_{inS2}$	M15L2	—	70	100	—	dB	

CHARACTERISTIC	SELECT MODE	SYMBOL	TEST CIR-CUIT	MIN.	TYP.	MAX.	UNIT	TEST METHOD
$R_{out2}$ Input Dynamic Range	$R_{inTV}$	VDR6R2	—	6.0	6.5	—	$V_{p-p}$	(1) Apply a 1kHz sine wave to each input pin. (2) In each select mode, measure an input amplitude at which the output waveform on pin 2 begins to be distorted.
	$R_{inV1}$	VDR9R2	—	6.0	6.5	—	$V_{p-p}$	
	$R_{inV2}$	VDR31R2	—	6.0	6.5	—	$V_{p-p}$	
	$R_{inS1}$	VDR13R2	—	6.0	6.5	—	$V_{p-p}$	
	$R_{inS2}$	VDR17R2	—	6.0	6.5	—	$V_{p-p}$	
$R_{out2}$ Gain	$R_{inTV}$	G6R2	—	-0.5	0	0.5	dB	(1) Apply a 1kHz, 1.0V <sub>p-p</sub> sine wave to each input pin. (2) In each select mode, find the gain between input and output.
	$R_{inV1}$	G9R2	—	-0.5	0	0.5	dB	
	$R_{inV2}$	G31R2	—	-0.5	0	0.5	dB	
	$R_{inS1}$	G13R2	—	-0.5	0	0.5	dB	
	$R_{inS2}$	G17R2	—	-0.5	0	0.5	dB	
$R_{out2}$ Frequency Response	$R_{inTV}$	F6R2	—	0.1	2.0	—	MHz	(1) Apply a 1.0V <sub>p-p</sub> sine wave to each input pin. (2) In each select mode, measure a frequency at which the output amplitude on pin 2 is 3dB down from the 1kHz applied level.
	$R_{inV1}$	F9R2	—	0.1	2.0	—	MHz	
	$R_{inV2}$	F31R2	—	0.1	2.0	—	MHz	
	$R_{inS1}$	F13R2	—	0.1	2.0	—	MHz	
	$R_{inS2}$	F17R2	—	0.1	2.0	—	MHz	
$R_{out2}$ Crosstalk	$R_{inTV}$	CT6R2	—	70	100	—	dB	(1) Apply a 1kHz, 1.0V <sub>p-p</sub> sine wave to each input pin. (2) In each select mode, compare signal output from the selected pin with leakage components from nonselected pins to find a crosstalk.
	$R_{inV1}$	CT9R2	—	70	100	—	dB	
	$R_{inV2}$	CT31R2	—	70	100	—	dB	
	$R_{inS1}$	CT13R2	—	70	100	—	dB	
	$R_{inS2}$	CT17R2	—	70	100	—	dB	
$R_{out2}$ Mute Attenuation	$R_{inTV}$	M6R2	—	70	100	—	dB	(1) Apply a 1kHz, 1.0V <sub>p-p</sub> sine wave to each input pin. (2) In each select mode, compare the output amplitudes on pin 2 when mute is turned on and turned off to find mute attenuation.
	$R_{inV1}$	M9R2	—	70	100	—	dB	
	$R_{inV2}$	M31R2	—	70	100	—	dB	
	$R_{inS1}$	M13R2	—	70	100	—	dB	
	$R_{inS2}$	M17R2	—	70	100	—	dB	
$L_{outTV}$ Input Dynamic Range	$L_{inTV}$	VDR5LTV	—	6.0	6.5	—	$V_{p-p}$	While applying a 1kHz sine wave to pin 5, measure an input amplitude at which the output waveform on pin 40 begins to be distorted.

CHARACTERISTIC	SELECT MODE	SYMBOL	TEST CIRCUIT	MIN.	TYP.	MAX.	UNIT	TEST METHOD
$L_{outTV}$ Gain	$L_{inTV}$	G5LTV	—	-0.5	0	0.5	dB	While applying a 1kHz, 1.0V <sub>p-p</sub> sine wave to pin 5, find the gain between pins 5 and 40.
$L_{outTV}$ Frequency Response	$L_{inTV}$	F5LTV	—	0.1	2.0	—	MHz	While applying a 1.0V <sub>p-p</sub> sine wave to pin 5, measure a frequency at which the output waveform on pin 40 is 3dB down from the 1kHz applied level.
$L_{outTV}$ Crosstalk	$L_{inTV}$	CT5LTV	—	70	100	—	dB	(1) Apply a 1kHz, 1.0V <sub>p-p</sub> sine wave to each input pin. (2) Compare the output amplitude when $L_{inTV}$ is selected with leakage components from nonselected pins to find a crosstalk.
	$L_{inV1}$	CT8LTV	—	70	100	—	dB	
	$L_{inV2}$	CT29LTV	—	70	100	—	dB	
	$L_{inS1}$	CT11LTV	—	70	100	—	dB	
	$L_{inS2}$	CT15LTV	—	70	100	—	dB	
$L_{outTV}$ Mute Attenuation	$L_{inTV}$	M5LTV	—	70	100	—	dB	While applying a 1kHz, 1.0V <sub>p-p</sub> sine wave to pin 5, compare the output amplitudes on pin 40 when mute is turned on and turned off to find mute attenuation.
$R_{outTV}$ Input Dynamic Range	$R_{inTV}$	VDR6RTV	—	6.0	6.5	—	V <sub>p-p</sub>	While applying a 1kHz sine wave to pin 6, measure an input amplitude at which the output waveform on pin 39 begins to be distorted.
$R_{outTV}$ Gain	$R_{inTV}$	G6RTV	—	-0.5	0	0.5	dB	While applying a 1kHz, 1.0V <sub>p-p</sub> sine wave to pin 6, find the gain between pins 6 and 39.
$R_{outTV}$ Frequency Response	$R_{inTV}$	F6RTV	—	0.1	2.0	—	MHz	While applying a 1.0V <sub>p-p</sub> sine wave to pin 6, measure a frequency at which the output waveform on pin 39 is 3dB down from the 1kHz applied level.

CHARACTERISTIC	SELECT MODE	SYMBOL	TEST CIR-CUIT	MIN.	TYP.	MAX.	UNIT	TEST METHOD
R <sub>out</sub> TV Crosstalk	R <sub>in</sub> TV	CT6RTV	—	70	100	—	dB	(1) Apply a 1kHz, 1.0V <sub>p-p</sub> sine wave to each input pin. (2) Compare the output amplitude when R <sub>in</sub> TV is selected with leakage components from nonselected pins to find a crosstalk.
	R <sub>in</sub> V1	CT9RTV	—	70	100	—	dB	
	R <sub>in</sub> V2	CT31RTV	—	70	100	—	dB	
	R <sub>in</sub> S1	CT13RTV	—	70	100	—	dB	
	R <sub>in</sub> S2	CT17RTV	—	70	100	—	dB	
R <sub>out</sub> TV Mute Attenuation	R <sub>in</sub> TV	M6RTV	—	70	100	—	dB	While applying a 1kHz, 1.0V <sub>p-p</sub> sine wave to pin 6, compare the output amplitudes on pin 39 when mute is turned on and turned off to find mute attenuation.

APPLICATION CIRCUIT

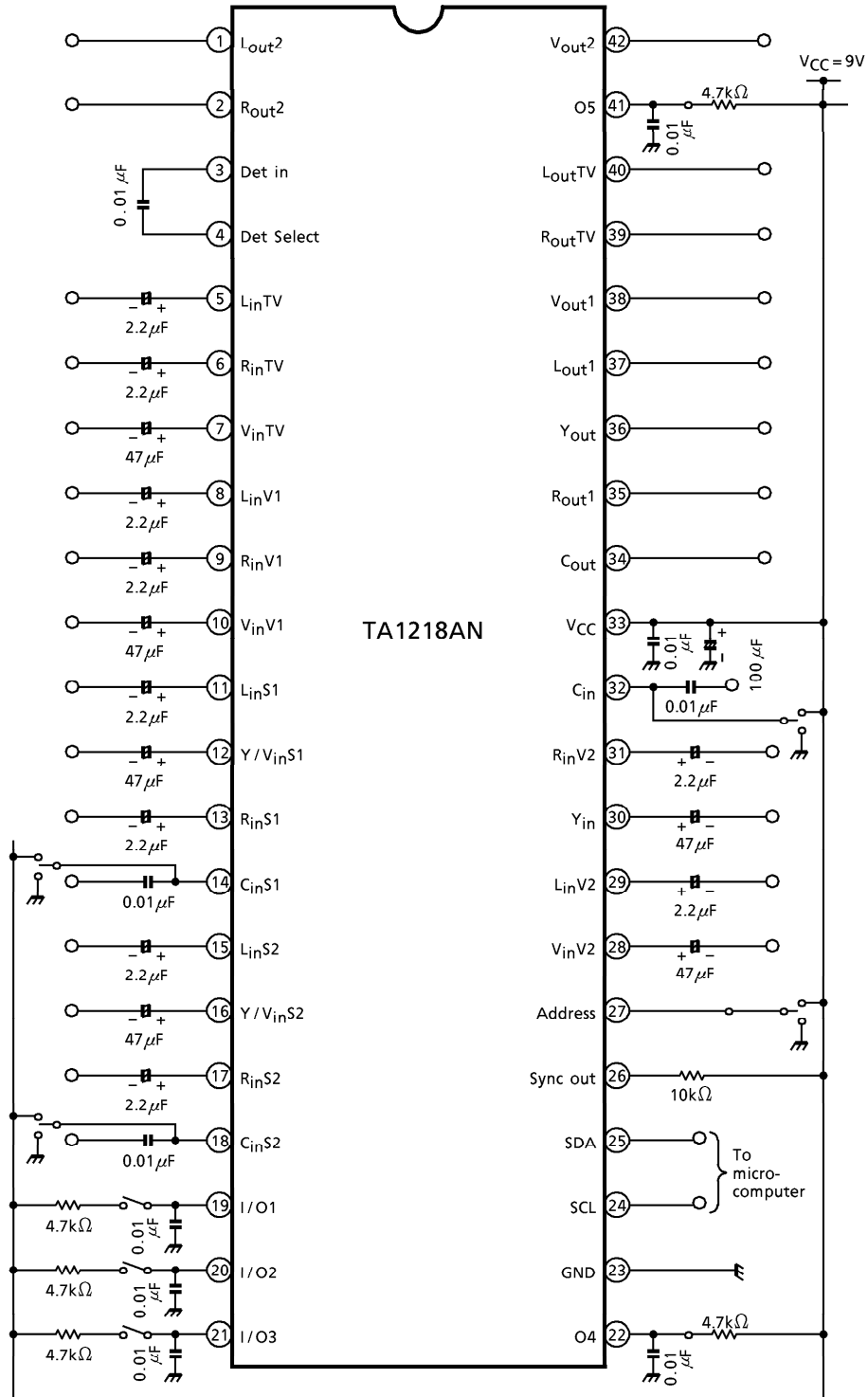

**OUTLINE DRAWING**  
SDIP42-P-600-1.78

Unit : mm

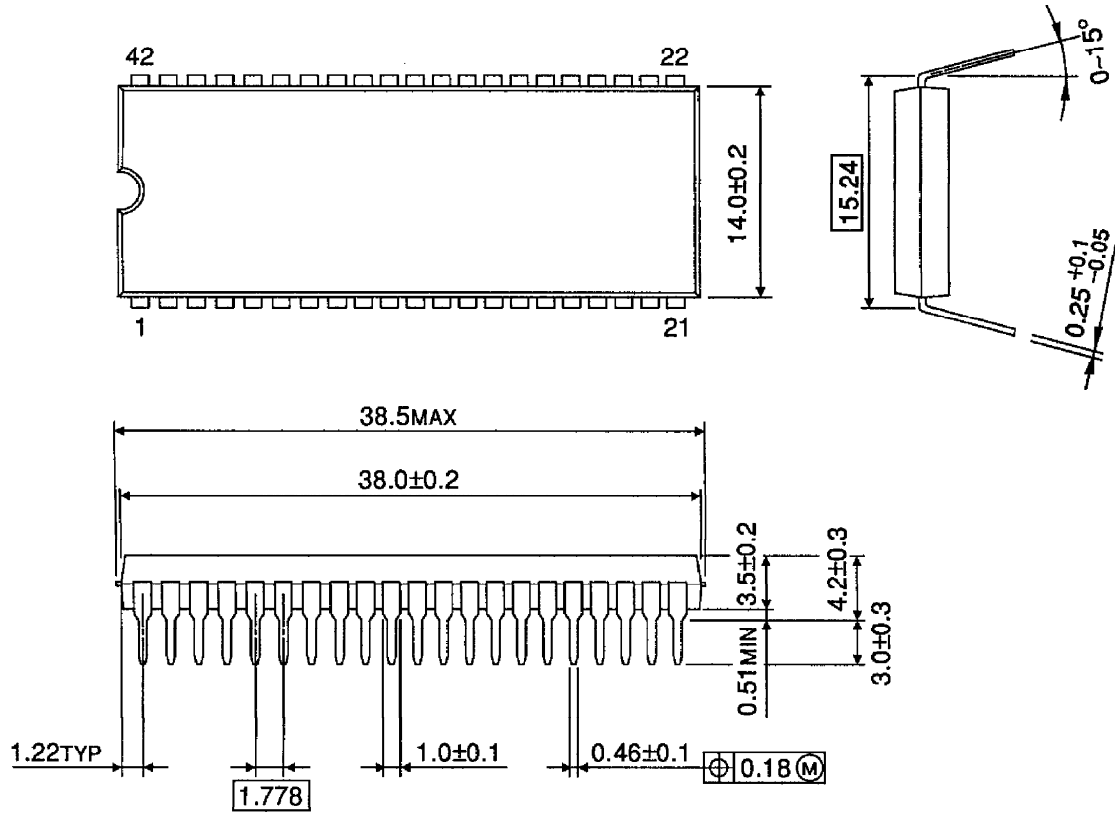

Weight : 4.13g (Typ.)