

TOSHIBA

TA8529F

TOSHIBA BIPOLAR LINEAR INTEGRATED CIRCUIT MULTI-CHIP PACKAGE

TA8529F

Stepping Motor Driver IC (TA8528 + 2SA950 × 4 MCP)

TA8529F is a stepping motor driver IC which operates based on bipolar transistors. The device incorporates stepping motor driver IC TA8528 and four PNP transistors 2SA950 configuring a multi-chip package. It also incorporates a standby function and two bridge drivers which enable an inductive load to be driven by the bipolar transistors. Four-port inputs allow driving by 1-phase excitation, 2-phase excitation, or 1/2-phase excitation. Selecting the mode enables two-port inputs which allows driving by 2-phase excitation. The device can be used as a low-saturation-voltage bridge driver.

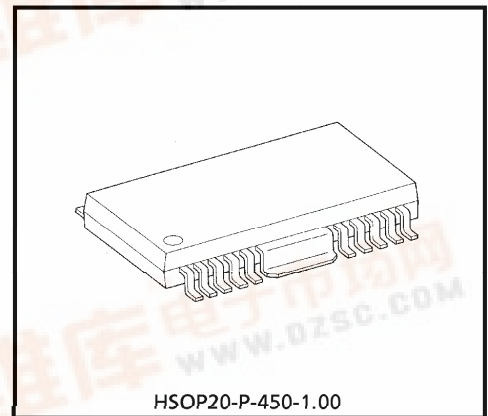

HSOP20-P-450-1.00

Weight : 0.79g (Typ.)

FEATURES

- Two low-saturation-voltage bridge drivers: saturation voltage < 0.95V (I_O = 400mA)
- 1-phase excitation, 2-phase excitation, 1/2-phase excitation enabled by four-port inputs (pin 11 open)
- 2-phase excitation enabled by two-port inputs (pins 8, 9, 11 grounded)
- Built-in standby function
- Built-in rush-current protector circuit for when switching excitation current
- Standard 20-pin PFP
- GND pin = heat sink

BLOCK DIAGRAM

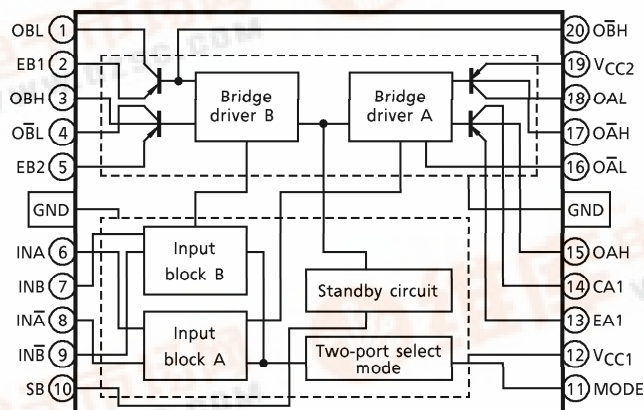

961001EBA2

- TOSHIBA is continually working to improve the quality and the reliability of its products. Nevertheless, semiconductor devices in general can malfunction or fail due to their inherent electrical sensitivity and vulnerability to physical stress. It is the responsibility of the buyer, when utilizing TOSHIBA products, to observe standards of safety, and to avoid situations in which a malfunction or failure of a TOSHIBA product could cause loss of human life, bodily injury or damage to property. In developing your designs, please ensure that TOSHIBA products are used within specified operating ranges as set forth in the most recent products specifications. Also, please keep in mind the precautions and conditions set forth in the TOSHIBA Semiconductor Reliability Handbook.
- The products described in this document are subject to foreign exchange and foreign trade control laws.
- The information contained herein is presented only as a guide for the applications of our products. No responsibility is assumed by TOSHIBA CORPORATION for any infringements of intellectual property or other rights of the third parties which may result from its use. No license is granted by implication or otherwise under any intellectual property or other rights of TOSHIBA CORPORATION or others.
- The information contained herein is subject to change without notice.

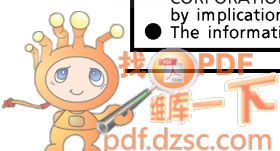

PIN FUNCTION

PIN No.	PIN NAME	FUNCTION	I/O
1	OBL	Bridge driver B output pin	O
2	EB1	PNP transistor emitter pin	—
3	OBH	PNP transistor base pin	—
4	O \bar{B} L	Bridge driver B output pin	O
5	EB2	PNP transistor emitter pin	—
6	INA	Channel A excitation input pin	I
7	INB	Channel B excitation input pin	I
8	IN \bar{A}	Channel A excitation input pin	I
9	IN \bar{B}	Channel B excitation input pin	I
10	SB	Standby function input pin	I
11	MODE	Two-port input select mode pin	I
12	V $_{CC1}$	5V supply pin	—
13	EA1	PNP transistor emitter pin	—
14	CA1	PNP transistor collector pin	—
15	OAH	PNP transistor base pin	—
16	O \bar{A} L	Bridge driver A output pin	O
17	O \bar{A} H	PNP transistor base pin	—
18	OAL	Bridge driver A output pin	O
19	V $_{CC2}$	5V / 12V supply pin	—
20	OBH	PNP transistor base pin	—
F	S.GND P.GND	Small signal ground pin Power ground pin	—

LOGIC CHART

INPUT				OUTPUT		
SB	MODE	INA (B)	IN \bar{A} (\bar{B})	OA (B) L	O \bar{A} (\bar{B}) L	
L	H	L	L	∞	∞	OPERATION
L	H	H	H	∞	∞	OPERATION
L	H	H	L	L	H	OPERATION
L	H	L	H	H	L	OPERATION
L	L	L	L	H	L	OPERATION
L	L	H	L	L	H	OPERATION
H	X	X	X	∞	∞	STAND-BY

X : Don't Care
 ∞ : High impedance

TIMING CHART 1

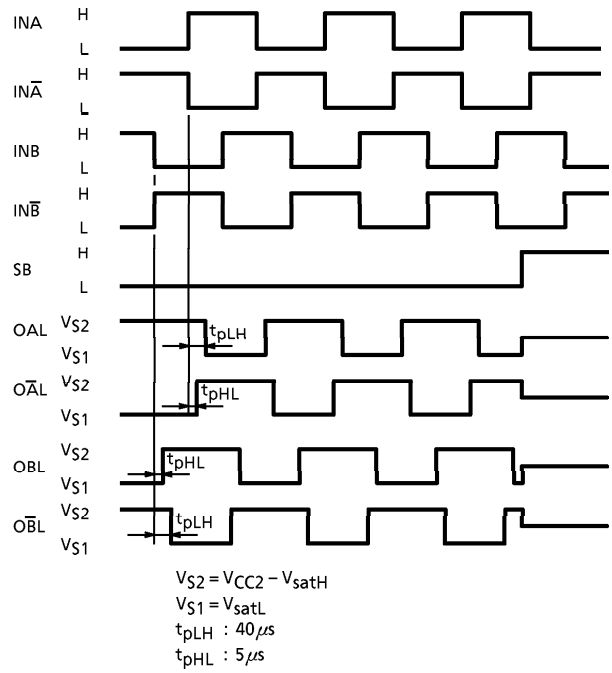

TIMING CHART 2

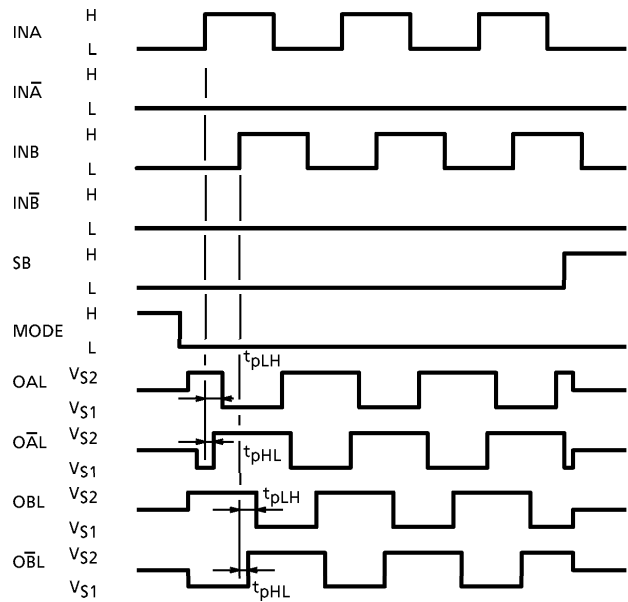

MAXIMUM RATINGS (Ta = 25°C)

CHARACTERISTICS	SYMBOL	RATING	UNIT
Power supply voltage	V _{CC1}	7.0	V
	V _{CC2}	17.0	
Output current	I _O (MAX)	± 500	mA
Input voltage	V _{IN}	~V _{CC1}	V
Power dissipation	P _D	1.0	W
Operating temperature	T _{opr}	(Note) - 30~75	°C
Storage temperature	T _{stg}	- 55~150	°C

(Note) Depending on the operating temperature, output current may be restricted. (See Pd-Ta characteristics graph.)

RECOMMENDED OPERATING CONDITION

CHARACTERISTICS	SYMBOL	TEST CIRCUIT	TEST CONDITION	MIN.	TYP.	MAX.	UNIT
Power supply voltage	V _{CC1}	—	—	4.5	—	5.5	V
	V _{CC2}	—	—	4.5	—	13.2	

Package PFP-20 characteristics

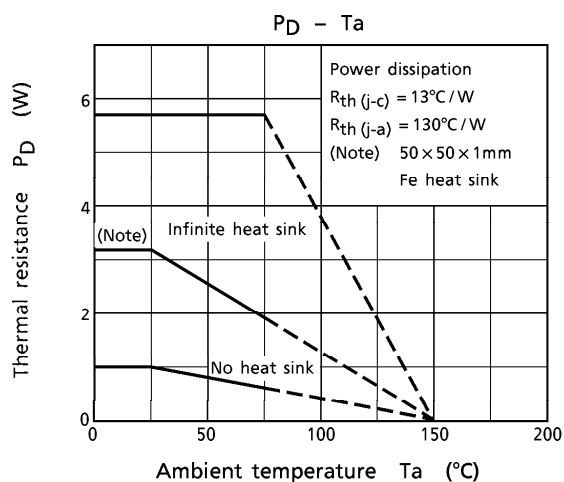

ELECTRICAL CHARACTERISTICS (Ta = 25°C, VCC1 = 5V, VCC2 = 12V)

CHARACTERISTICS	SYMBOL	TEST CIR-CUIT	TEST CONDITION	MIN.	TYP.	MAX.	UNIT	
Supply Current	I _{CC1}	—	V _{SB} = 5V, output open	—	—	5	μA	
	I _{CC2}			—	—	10		
	I _{CC1}	—	V _{SB} = 5V, output open 1 input = 5V, 3 inputs = 0V	—	—	5	μA	
	I _{CC2}			—	—	10		
	I _{CC1}	—	V _{SB} = 5V, output open A : 1 input = 5V, B : 1 input = 5V A : 1 input = 0V, B : 1 input = 0V	—	—	5	μA	
	I _{CC2}			—	—	10		
	I _{CC1}	—	Output open, V _{SB} = 0V 1 input = 5V, 3 inputs = 0V	—	25	30	mA	
	I _{CC2}			—	20	25		
	I _{CC1}	—	Output open, V _{SB} = 0V A : 1 input = 5V, B : 1 input = 5V A : 1 input = 0V, B : 1 input = 0V	—	35	44	mA	
	I _{CC2}			—	35	47		
	I _{CC1}	—	Output open, V _{SB} = 0V V _{MODE} = 0V, input = 0V	—	35	44	mA	
	I _{CC2}			—	35	47		
Input Voltage	V _{INH}	—	Pins 6, 7, 8, and 9	2.0	—	V _{CC1}	V	
	V _{INL}			GND	—	0.8		
	V _{SBH}	—	Pin 10	3.5	—	V _{CC1}	V	
	V _{SBL}			GND	—	2.0		
	V _{MODEH}	—	Pin 11	3.5	—	V _{CC1}	V	
	V _{MODEL}			GND	—	2.0		
Input Current	I _{INH}	—	V _{IN} = 3.5V	Pins 6, 7, 8, and 9	—	-2	-10	μA
	I _{INL}	—	V _{IN} = 0.4V		—	-200	-300	
	I _{SBH}	—	V _{SB} = 3.5V	Pin 10	—	-30	-45	μA
	I _{SBL}	—	V _{SB} = 0.4V		—	-150	-220	
Saturation voltage (Note) V _{sat1} = V _{satH1} + V _{satL1} V _{sat2} = V _{satH2} + V _{satL2}	V _{satH1}	—	I _O = 100mA	—	0.1	—	V	
	V _{satH2}	—	I _O = 400mA	—	0.15	—		
	V _{satL1}	—	I _O = 100mA	—	0.1	—	V	
	V _{satL2}	—	I _O = 400mA	—	0.45	—		
	V _{sat1}	—	I _O = 100mA	—	0.2	0.4	V	
	V _{sat2}	—	I _O = 400mA	—	0.6	0.95		
Diode Forward Voltage	V _F	—	I _F = 400mA	—	1.4	1.6	V	
Delay time During	t _{pLH}	—	IN-φ	—	40	—	μs	
	t _{pHL}			—	5	—		

APPLICATION CIRCUIT

1. Four-input method

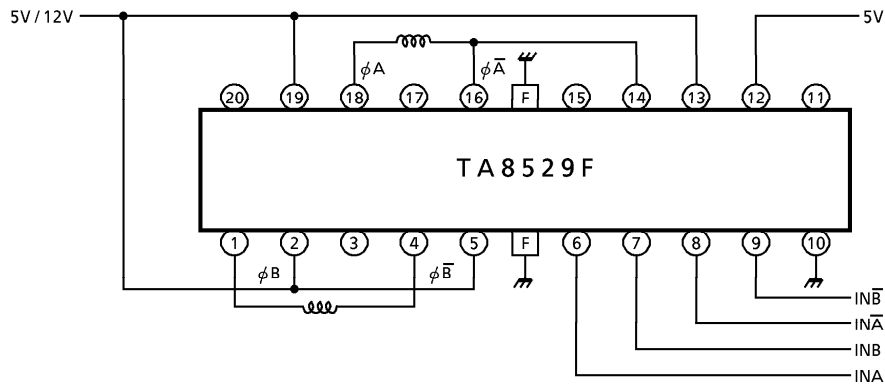

2. Two-input method

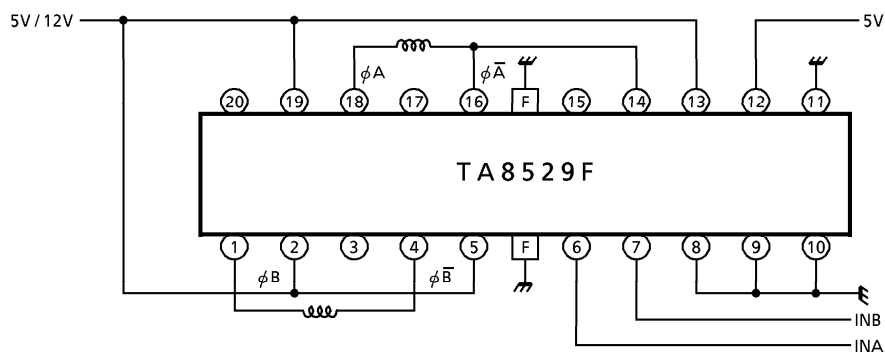

3. Power save application circuit

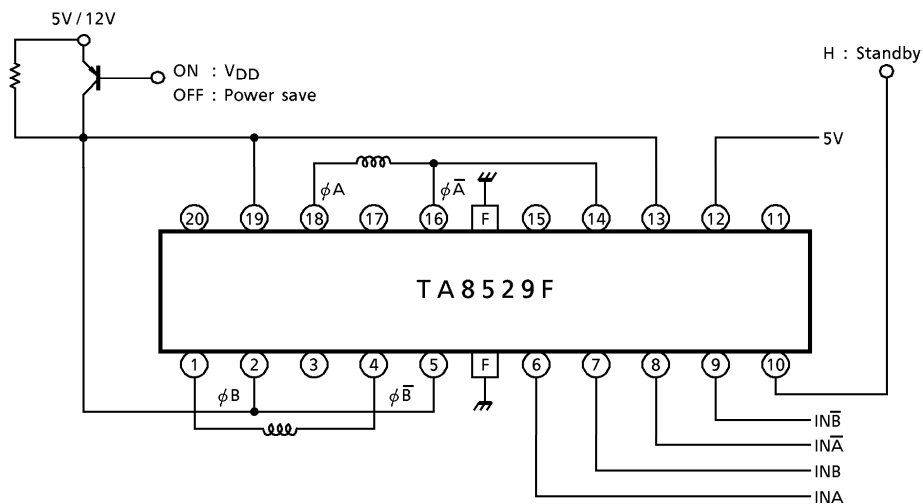

PACKAGE DRAWING
HSOP20-P-450-1.00

Unit : mm

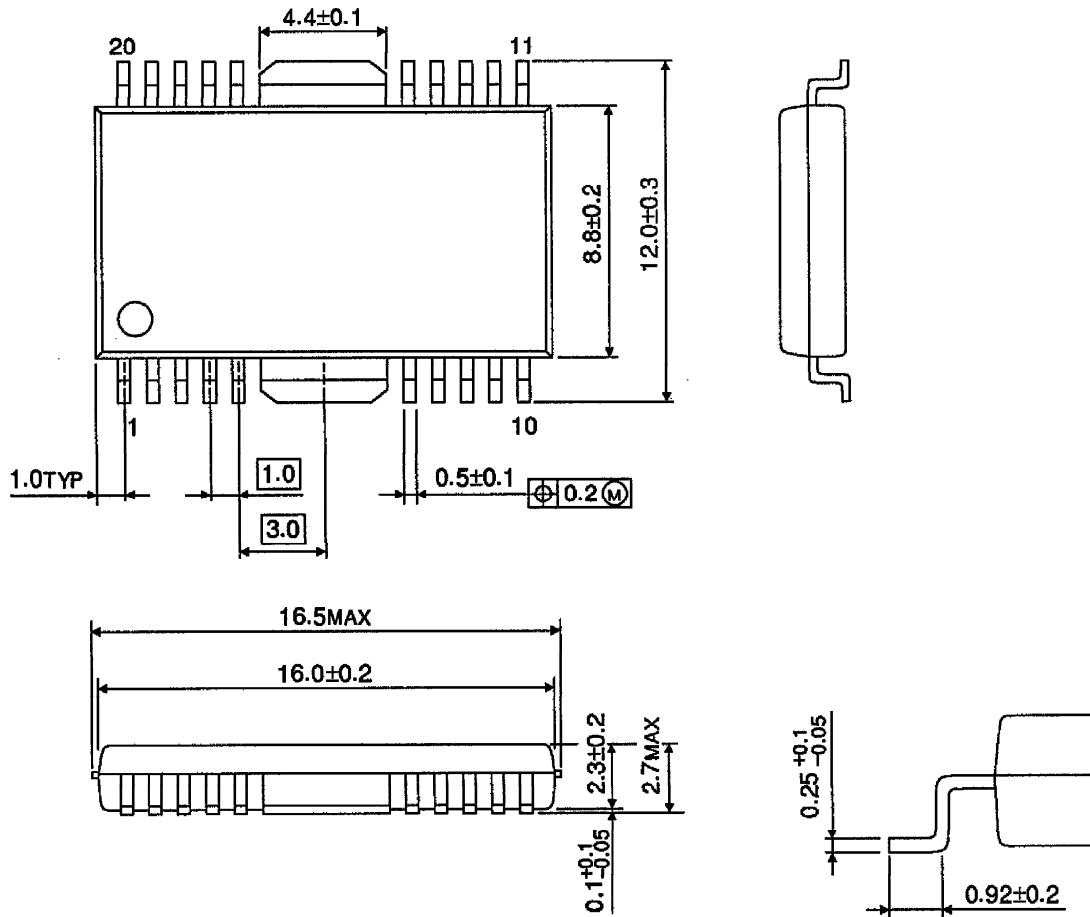

Weight : 0.79g (Typ.)