

TOSHIBA

TA8801AN

TOSHIBA BIPOLAR LINEAR INTEGRATED CIRCUIT SILICON MONOLITHIC

TA8801AN

VIDEO / CHROMA / DEFLECTION PROCESSOR IC FOR NTSC COLOR TV

TA8801AN is an integrated circuit for NTSC color TV, which has a function of Video / Chroma / Deflection Processor inside a 36-pin shrink DIP plastic package. This is most suitable for high-definition, large-screen televisions.

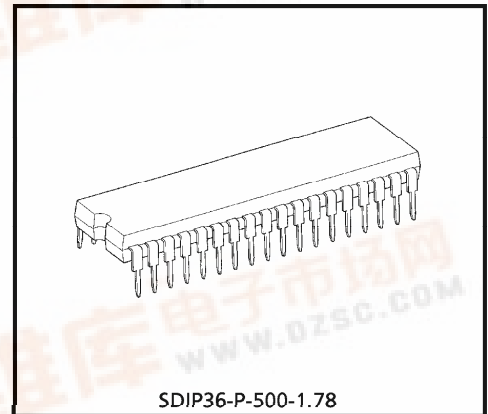

SDIP36-P-500-1.78

Weight : 2.98g (Typ.)

FEATURES

Video section

- Black stretch circuit
- Contour improvement by built-in delay lines
- High-brightness color
- DC restoration

On-screen-display section

- OSD by digital R / G / B inputs
- Picture mute
- Contrast controllable

Deflection section

- High-performance sync. separator circuit
- Adjustment-free oscillator circuit based on count-down system
- Horizontal phase adjustable
- X-ray protection circuit

Chroma section

- R-Y, B-Y axes demodulation
- Automatic phase control (Adjustment-free)

961001EBA2

- TOSHIBA is continually working to improve the quality and the reliability of its products. Nevertheless, semiconductor devices in general can malfunction or fail due to their inherent electrical sensitivity and vulnerability to physical stress. It is the responsibility of the buyer, when utilizing TOSHIBA products, to observe standards of safety, and to avoid situations in which a malfunction or failure of a TOSHIBA product could cause loss of human life, bodily injury or damage to property. In developing your designs, please ensure that TOSHIBA products are used within specified operating ranges as set forth in the most recent products specifications. Also, please keep in mind the precautions and conditions set forth in the TOSHIBA Semiconductor Reliability Handbook.
- The products described in this document are subject to foreign exchange and foreign trade control laws.
- The information contained herein is presented only as a guide for the applications of our products. No responsibility is assumed by TOSHIBA CORPORATION for any infringements of intellectual property or other rights of the third parties which may result from its use. No license is granted by implication or otherwise under any intellectual property or other rights of TOSHIBA CORPORATION or others.
- The information contained herein is subject to change without notice.

BLOCK DIAGRAM

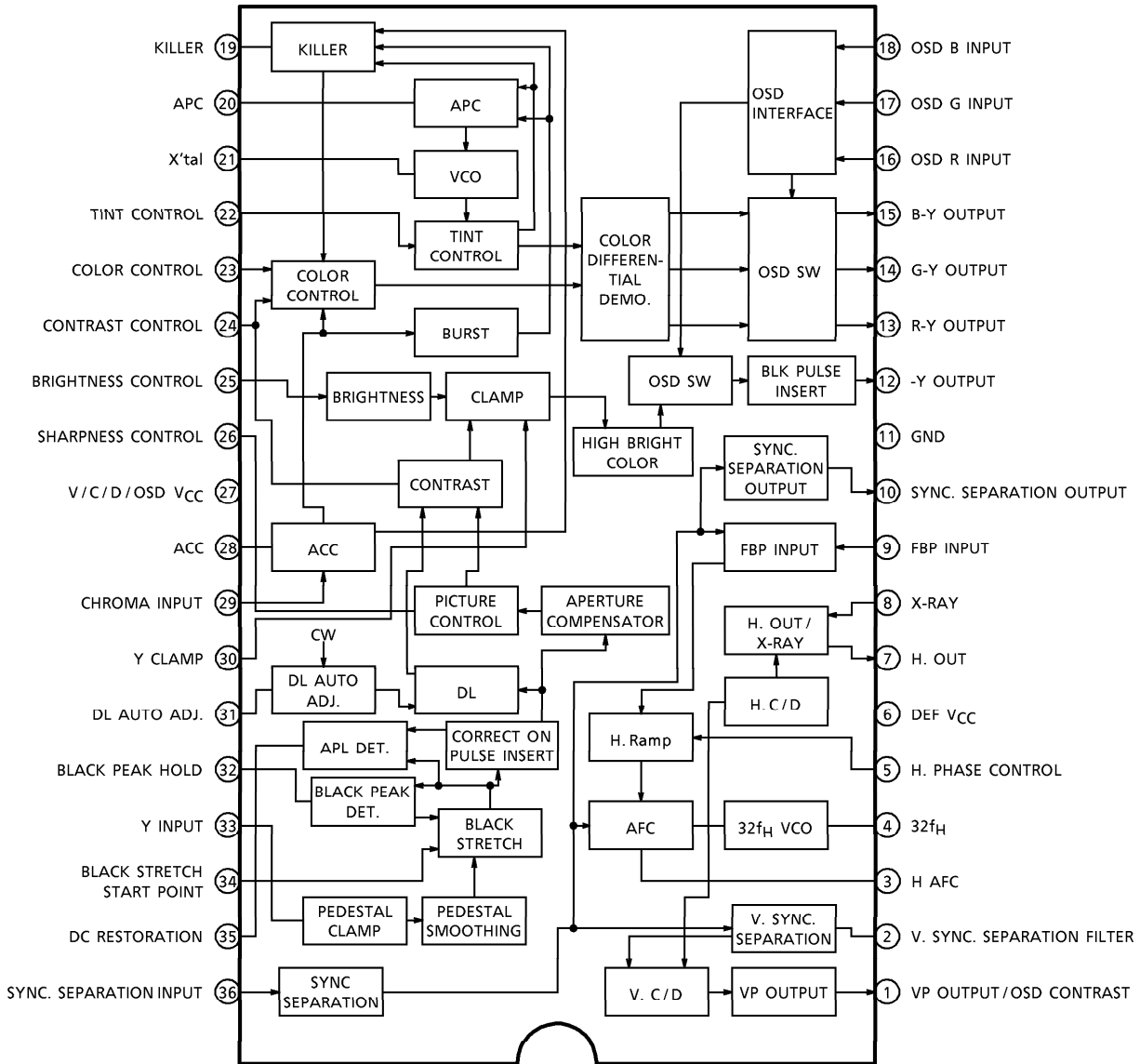

TERMINAL FUNCTION

PIN No.	PIN NAME	FUNCTION	INTERFACE CIRCUIT
1	Vertical Pulse Output / OSD Contrast	The terminal for vertical pulse output. And OSD contrast is adjusted by the DC voltage supplied this terminal.	
2	Vertical Sync. Separation Filter	The terminal for vertical sync. separation filter.	
3	H. AFC Filter	The terminal for horizontal AFC filter.	
4	32 f _H VCO	The terminal for 32f _H (503kHz) ceramic resonator. CSB503F30 (Murata Manufacturing Co. product) is recommended.	
5	Horizontal Phase Control	Horizontal phase is adjusted by DC voltage supplied this terminal. The variable range is 2.4μs (Typ.).	
7	Horizontal Pulse Output	Horizontal pulse is outputted from this terminal. Its amplitude is 5.0V _{p-p} (typ.) and duty is 43% (typ). Output form is emitter follower. And keep the output current less than 12mA.	

PIN No.	PIN NAME	FUNCTION	INTERFACE CIRCUIT
8	X-ray Protection	The terminal for an overvoltage protection circuit. The threshold level is 3.65V (typ.). The horizontal output terminal (pin 9) is pulled Low when a voltage applied to this pin is greater than the threshold level.	
9	FBP Input	The terminal for flyback pulse input.	
10	Sync. Separation Output	The terminal for a sync. signal output. Output form is an open-collector. And the current flowing into is 0.15mA (typ.).	
12	-Y Output	The terminal for -Y output. Blanking can be disabled by connecting a resistor between this pin and GND and flowing a current more than 0.2mA. And keep the output current less than 2.5mA.	
13 14 15	R-Y Output G-Y Output B-Y Output	The terminals for color-difference signals output. Keep the output current less than 4.8mA.	
16 17 18	R Input G Input B Input	The terminals for OSD signals input. The threshold voltage is 0.75V (typ.).	

PIN No.	PIN NAME	FUNCTION	INTERFACE CIRCUIT
19	Killer Filter	The terminal to be connected a killer filter.	
20	APC Filter	The terminal to be connected an APC filter.	
21	X'tal	The terminal to be connected a 3.58MHz crystal resonator for the VCXO.	
22	Tint Control	The terminal for tint control. Control voltage is 0V to 5V.	
23	Color Control	The terminal for color control. Control voltage is 0V to 5V. The voltage of this terminal turns to low level while the color killer is on.	
24	Contrast Control	The terminal for contrast control. Control voltage is 0V to 5V.	
25	Brightness Control	The terminal for brightness control. Control voltage is 0V to 5V.	

PIN No.	PIN NAME	FUNCTION	INTERFACE CIRCUIT
26	Sharpness Control	The terminal for sharpness control. Control voltage is 0V to 5V.	
28	ACC	The terminal to be connected the ACC filter.	
29	Chroma Input	The terminal for chroma input. The standard input level is 286mV _{p-p} in burst amplitude.	
30	Y Clamp	The terminal to be connected a Y clamp filter. Use a low leak capacitor for this filter.	
31	Delay Time Automatic Adjustment	The terminal to be connected a filter for a delay time automatic adjustment circuit for the internal delay line. Use a low leak capacitor for this filter.	

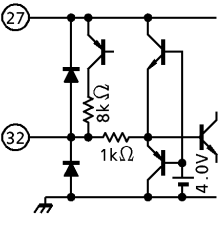
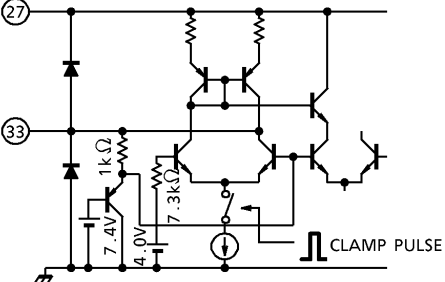
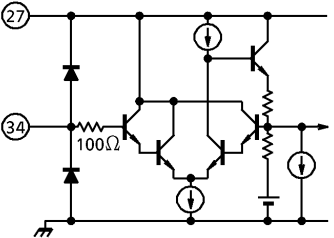
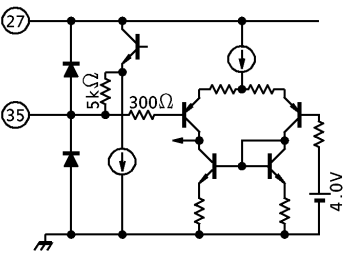
PIN No.	PIN NAME	FUNCTION	INTERFACE CIRCUIT
32	Black Peak Hold	<p>The terminal for a filter to hold black peak. The voltage of this terminal can control the gain of black stretch amplifier. When the voltage is higher than pedestal level, the gain goes up and when the voltage is lower, the gain goes down. Black stretch is turned off by supplying 5V or more to this terminal.</p>	
33	Y Input	<p>The terminal for input of luminance signal (negative sync., 1.0V_{p-p}). -Y output turns out 4.0V_{p-p} with contrast max. Because the pedestal level is clamped at the input pin, the signal source's impedance must be sufficiently low. The pedestal voltage is clamped to 4.0V (typ.).</p>	
34	Black Stretch Start Point	<p>The terminal for setting the start point of black stretch. The higher the voltage of this terminal is. The higher the start point is.</p>	
35	DC Restoration	<p>The terminal to adjust DC restoration ratio. The DC restoration ratio (T_{DC}) is determined by the equation below.</p> $T_{DC} = \frac{5k\Omega}{5k\Omega + R\Omega} \times 30 + 100 [\%]$ <p>The smaller the value of external resistance R, the greater the amount of correction. You can monitor a black-stretched Y signal with the sync. signal eliminated by leaving this terminal open.</p>	

PIN No.	PIN NAME	FUNCTION	INTERFACE CIRCUIT
36	Sync Separation Input	The terminal for input of the sync. separation circuit. Input a 2V _{p-p} video signal with negative sync. Because the coupling capacitor also functions as a sync separation filter, make sure the signal source's impedance is sufficiently low. Use a low leak capacitor for coupling.	

MAXIMUM RATINGS (Ta = 25°C)

CHARACTERISTIC	SYMBOL	RATING	UNIT
Supply Voltage	V _{CC}	15	V
Power Dissipation	P _{Dmax}	1.8 (Note)	W
Input Signal Voltage	e _{in}	5	V _{p-p}
Operating Temperature	T _{opr}	- 20~65	°C
Storage Temperature	T _{stg}	- 55~150	°C

(Note) When using this device at a temperature higher than 25°C, deduct 14.4mW from the above rated value for each increment of 1°C.

ELECTRICAL CHARACTERISTICS

DC VOLTAGE CHARACTERISTICS (Unless otherwise specified V_{CC} = 12V, H.V_{CC} = 9V, Ta = 25°C)

PIN No.	PIN NAME	SYMBOL	PIN VOLTAGE (V)			MEASURING CONDITION
			MIN.	TYP.	MAX.	
1	VP output / OSD contrast	V ₁	7.40	7.70	8.00	—
3	H AFC	V ₃	7.00	7.50	8.00	—
4	32f _H	V ₄	5.70	6.00	6.30	—
5	Horizontal position adjustment	V ₅	4.25	4.50	4.75	—
7	Horizontal output	V ₇	2.30	2.50	2.70	—
9	Flyback pulse input	V ₉	0.48	0.53	0.58	—
10	Sync separation output	V ₁₀	—	9.00	—	R _L = 10kΩ (to V _{CC})
12	-Y output	V ₁₂	6.90	7.20	7.50	—
13	R-Y output	V ₁₃	7.00	7.50	8.00	—
14	G-Y output	V ₁₄	7.00	7.50	8.00	—
15	B-Y output	V ₁₅	7.00	7.50	8.00	—
19	Killer filter	V ₁₉	7.70	7.90	8.10	With no input
20	APC filter	V ₂₀	8.60	8.90	9.20	—
21	3.58MHz X'tal	V ₂₁	5.75	5.95	6.15	With this terminal open
22	Tint control	V ₂₂	2.30	2.50	2.70	—

PIN No.	PIN NAME	SYMBOL	PIN VOLTAGE (V)			MEASURING CONDITION
			MIN.	TYP.	MAX.	
23	Color control	V23	2.30	2.50	2.70	Killer turned off
24	Contrast control	V24	2.30	2.50	2.70	—
25	Bright control	V25	—	2.50	—	—
26	Picture quality adjustment	V26	—	2.50	—	—
28	ACC filter	V28	10.60	11.30	12.00	With no input
29	Chroma input	V29	4.50	4.70	4.90	—
30	Y clamp	V30	5.40	6.40	7.40	Bright 2.5V / FBP inputted
31	Delay time automatic adjustment	V31	6.60	7.40	8.20	—
32	Black peak hold	V32	4.20	4.50	4.80	—
33	Bright input	V33	3.80	4.00	4.20	—
34	Black stretch	V34	3.80	4.00	4.20	—
35	DC restoration	V35	3.80	4.00	4.20	—
36	Sync separation input	V36	2.00	2.25	2.50	AC GND / FBP inputted

Current consumption

(Unless otherwise specified, $V_{CC} = 12V$, $H.V_{CC} = 9V$ at $T_a = 25^\circ C$)

PIN No.	PIN NAME	SYMBOL	CURRENT CONSUMPTION (mA)		
			MIN.	TYP.	MAX.
6	DEF V_{CC}	I_{CC} 6pin	8.5	20.0	33.0
27	V / C / OSD V_{CC}	I_{CC} 27pin	43.5	56.5	93.0

AC CHARACTERISTICS (Unless otherwise specified, $V_{CC} = 12V$, $H.V_{CC} = 9V$, $T_a = 25^\circ C$)

Video and OSD section

CHARACTERISTIC	SYMBOL	TEST CIRCUIT	TEST CONDITION	MIN.	TYP.	MAX.	UNIT
Y Input Pedestal Clamp Voltage	V33	1	(Note 1)	3.8	4.0	4.2	V
Input Pedestal Clamp Pulse Phase	TCL1	1	(Note 2)	7.20	7.65	8.10	μs
	TCL2			8.35	8.80	9.25	
DC Restoration Amp Gain	A_{V35}	1	(Note 3)	0.28	0.34	0.40	
Black Stretch Amp Maximum Gain	G_{VBE}	1	(Note 4)	1.35	1.45	1.55	
Y Input / Output Delay Time	T_Y	1	(Note 5)	110	120	130	ns
Y Input Dynamic Range	DR33	1	(Note 6)	0.9	1.1	1.3	V_{p-p}
Sharpness Control Range	G_{SMAX}	1	(Note 7)	+ 6.5	+ 8.5	+ 10.5	dB
	G_{SMIN}			- 2.5	- 4.5	- 6.5	
Sharpness Control Center Characteristic	G_{SCT}	1	(Note 8)	+ 2.0	+ 3.5	+ 5.0	dB
Black Stretch Start Point	VST1	1	(Note 9)	225	260	295	mV_{p-p}
	VST2			385	420	455	

CHARACTERISTIC	SYMBOL	TEST CIR-CUIT	TEST CONDITION	MIN.	TYP.	MAX.	UNIT
Black Peak Detection Period (Other Than Horizontal Blanking Interval)	T _{BPH}	1	(Note 10)	20	22	24	H
AC Gain	G _V	1	(Note 11)	4.6	5.2	5.8	
Frequency Characteristics	G _f	1	(Note 12)	-3	0	+3	dB
Contrast Adjustment Voltage Range	ΔV _{ct}	1	(Note 13)	0.29	0.44	0.66	V
Contrast Adjustment Center Voltage	V _{cto}	1	(Note 14)	2.30	2.50	2.72	V
Brightness Adjustment Voltage	V _{br}	1	(Note 15)	2.2	2.5	2.8	V
Brightness Adjustment Sensitivity	G _{br}	1	(Note 16)	-1.5	-1.7	-1.9	
DC Restoration	TDC	1	(Note 17)	—	0	50	mV
Minimum Output	V _{do1}	1	(Note 18)	—	0.6	0.9	V
Maximum Output	V _{do2}	1	(Note 19)	8.3	8.7	—	V
Vertical Blanking Output Level	V _V	1	(Note 20)	11.0	11.8	12.0	V
Sink Current During Vertical Blanking	I _V	1	(Note 21)	0.4	0.6	0.85	mA
High Bright Color Gain	G _{HBC}	1	(Note 22)	0.08	0.10	0.12	
OSD Output DC Voltage	V _{DCY}	2	(Note 23)	4.3	4.6	4.9	V
	V _{DCC}			4.7	5.0	5.3	V
OSD Output Maximum Voltage	V _{OSDMAX}	2	(Note 24)	8.2	8.4	8.6	V
OSD Mode Switching Threshold Voltage	V _{OSDSW}	2	(Note 25)	0.65	0.75	0.85	V
OSD High Voltage Switching Threshold Voltage	V _{OSDHISW}	2	(Note 26)	1.9	2.1	2.3	V
OSD Mode Switching Rise Time	τ _{ROSDY}	2	(Note 27)	—	35	100	ns
	τ _{ROSDC}			—	45	100	
OSD Mode Switching Rise Transfer Time	t _{ROSDY}	2	(Note 28)	—	30	100	ns
	t _{ROSDC}			—	40	100	
OSD Mode Switching Fall Time	τ _{FOSDY}	2	(Note 29)	—	20	100	ns
	τ _{FOSDC}			—	45	100	
OSD Mode Switching Fall Transfer Time	t _{FOSDY}	2	(Note 30)	—	25	100	ns
	t _{FOSDC}			—	45	100	
OSD High Voltage Switching Rise Time	τ _{ROSDHI}	2	(Note 31)	—	40	100	ns
OSD High Voltage Switching Rise Transfer Time	t _{ROSDHI}	2	(Note 32)	—	50	100	ns
OSD High Voltage Switching Fall Time	τ _{FOSDHI}	2	(Note 33)	—	45	100	ns
OSD High Voltage Switching Fall Transfer Time	t _{FOSDHI}	2	(Note 34)	—	50	100	ns

Chroma section

CHARACTERISTIC	SYMBOL	TEST CIR-CUIT	TEST CONDITION	MIN.	TYP.	MAX.	UNIT
ACC Characteristic	F ₁	3	(Note 35)	2.04	2.65	3.44	V _{p-p}
	e _a			0.34	0.67	1.00	
	A			0.90	1.00	1.30	
Color Control Characteristic	V ₂₃	3	(Note 36)	2.30	2.50	2.72	V
	ΔV ₂₃			0.29	0.44	0.66	
Contrast Control Characteristic	V ₂₄	3	(Note 37)	2.30	2.50	2.72	V
	ΔV ₂₄			0.29	0.44	0.66	
	e _u			15.9	18.0	20.1	dB
Maximum Input Level	E _{MAX}	3	(Note 38)	0.88	1.10	2.00	V _{p-p}
Killer On Input Level	e _{BK}	3	(Note 39)	1.12	2.24	5.62	mV _{p-p}
APC Frequency Control Sensitivity	β	3	(Note 40)	1.0	1.7	2.9	Hz/mV
APC Pull-In/ Hold Range	f _{PH}	3	(Note 41)	250	500	1000	Hz
	f _{PL}						
	f _{HH}						
	f _{HL}						
Color-Difference Output Level	e _R	3	(Note 42)	1.72	2.23	2.90	V _{p-p}
	e _G			0.63	0.82	1.06	
	e _B			2.04	2.65	3.44	
Color-Difference Output Relative Amplitude	e _R /e _B	3	(Note 43)	0.73	0.84	0.97	
	e _G /e _B			0.26	0.31	0.36	
Color-Difference Output Relative Phase	θ _{R-B}	3	(Note 44)	88	95	102	°
	θ _{G-B}			230	240	250	
Tint Control Characteristic	θ ₁	3	(Note 45)	35	45	55	°
	θ ₂			35	45	55	
	θ			80	90	100	
	V ₃₇			2.30	2.50	2.72	V
	ΔV ₃₇			0.29	0.44	0.66	
Color-Difference Maximum Output Level	E _R	3	(Note 46)	3.65	4.45	5.56	V _{p-p}
	E _G			1.35	1.65	2.06	
	E _B			4.35	5.30	6.62	
Residual Carrier Level	v _{13e}	3	(Note 47)	—	—	15	mV _{p-p}
	v _{14e}						
	v _{15e}						
Residual Harmonic Level	v _{13eH}	3	(Note 48)	—	—	75	mV _{p-p}
	v _{14eH}						
	v _{15eH}						

Deflection section

CHARACTERISTIC	SYMBOL	TEST CIRCUIT	TEST CONDITION	MIN.	TYP.	MAX.	UNIT
Sync Separation Input Sensitive Current	IIN36	4	(Note 49)	15	25	40	μ A
H. AFC Phase Detection Current	IDET	4	(Note 50)	230	330	470	μ A
Phase Detection Stop Period	TCO3	4	(Note 51)	—	258~6	—	H
32f _H VCO Oscillation Start Voltage	VON	4	(Note 52)	—	—	4.0	V
Horizontal Output Start Voltage	VHON	4	(Note 53)	4.3	4.9	5.3	V
Horizontal Free-Running Frequency	f _{HO}	4	(Note 54)	15.584	15.734	15.884	kHz
Horizontal Oscillation Frequency Variable Range	f _{HMAX}	4	(Note 55)	16.500	16.700	16.900	kHz
	f _{HMIN}			14.700	15.000	15.300	
Horizontal Oscillation Control Sensitivity	β _H	4	(Note 56)	2.2	2.5	2.8	kHz/V
Horizontal Output Pulse Duty Cycle	T _{H7}	4	(Note 57)	41	43	45	%
Horizontal Output Voltage	V _{H7}	4	(Note 58)	4.7	5.0	5.3	Hz
	V _{L7}			—	0	100	mV
Overvoltage Protection Detection Voltage	V _{SON}	4	(Note 59)	3.55	3.65	3.75	V
Overvoltage Protection Retention Voltage	V _{H6}	4	(Note 60)	—	—	2.5	V
Horizontal Sync Phase	S _{PH1}	4	(Note 61)	2.6	2.8	3.0	μ s
Gate Pulse Start Phase	G _{P1}	4	(Note 62)	5.2	5.5	5.8	μ s
Gate Pulse Width	G _{P2}	4	(Note 63)	1.8	2.1	2.4	μ s
Horizontal Screen Phase Adjustment Variable Range	Δ G5	4	(Note 64)	2.2	2.4	2.7	μ s
Vertical Free-Running Frequency	f _{VO}	4	(Note 65)	48	53	58	Hz
Vertical Output Pulse Width	Tr1	4	(Note 66)	—	10	—	H
	Tr2	4	(Note 67)	—	10	—	
Vertical Pull-In Range	f _{PV1}	4	(Note 68)	—	224.5	—	H
	f _{PV2}			—	296.5	—	

TEST CONDITION

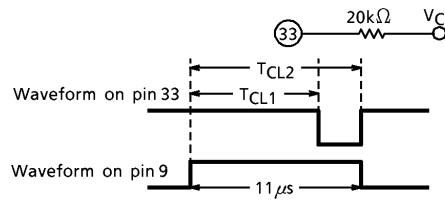
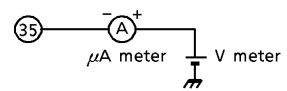
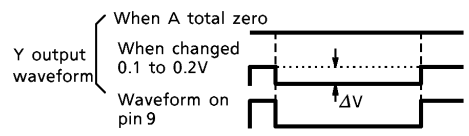
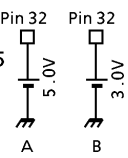
NOTE	ITEM	SYMBOL	MEASUREMENT CONDITION (V _{CD} .V _{CC} = 12V, Ta = 25 ± 3°C)								MEASUREMENT METHOD
			SW & VR MODE								
			SW02	SW24	SW26	SW32	SW33		VR24	VR26	
1	Y input pedestal clamp voltage	V33	ON	ON	OFF	A	A		Max.	Open	(1) Set Y input AC GND. (2) Set sync. separation input AC GND. (3) Connect 10kΩ between the vertical sync separation filter terminal (pin 2) and H.VCC (to set the V. free-run to 262.5H). (4) Measure the DC voltage on pin 33.
2	Y input pedestal clamp pulse phase	T _{CL1} T _{CL2}	↑	↑	↑	↑	↑		↑	↑	(1) Adjust VRH15 so that the HIGH level width of the waveform on pin 9 is 11μs. (2) Observe the waveform on pin 33. 
3	DC transmission rate compensation amp gain	A _{V35}	↑	↑	↑	↑	↑		↑	↑	(1) Under Note 1's condition adjust V meter to set μA meter reading 0A.  (2) While changing V meter's value, measure the variation of -Y output in picture period.  (3) $A_{V35} = \Delta V \div 0.1 \div Y \text{ Gain (G}_Y)$
4	Black stretch amp maximum gain	G _{VBE}	↑	↑	↑	↑	B		↑	↑	(1) Input a 0.1V _{p-p} , 500kHz sine wave into the Y input. (2) Apply 4.2V to pin 34. (3) Measure the amplitude on pin 35 under condition A. [V _A (V _{p-p})] (4) Measure the amplitude under condition B. [V _B (V _{p-p})]. (5) $G_{VBE} = V_B \div V_A$ 
5	Y input/output delay time	T _Y	OFF	↑	↑	↑	↑		↑	↑	(1) Input 2T pulse into Y input. (2) Measure the delay time between Y input (pin 33) and -Y output (pin 12).
6	Y input dynamic range	DR ₃₃	ON	↑	↑	↑	A		Min.	↑	(1) Connect the power supply to pin 33. (2) While raising the voltage from the value measured in Note 1, measure the voltage where -Y output voltage (pin 12) stops increasing. [V] $DR_{33} = V - V_{33}$

NOTE	ITEM	SYMBOL	MEASUREMENT CONDITION (V _{CD} , V _{CC} = 12V, T _a = 25 ± 3°C)								MEASUREMENT METHOD
			SW & VR MODE						VR24	VR26	
			SW02	SW24	SW26	SW32	SW33				
7	Sharpness control range	G _S MAX	ON	ON	ON	A	B		Max.	Max.	(1) Input a 50mV _{p-p} sine wave into Y input. (2) Set the Sharpness control to the maximum. (3) Measure the Y output amplitude at 10kHz [V _{10K}] and 2.4MHz [V _{pK}] and calculate. $G_{SMAX} = 20 \log (V_{pK} / V_{10K})$
		G _S MIN	↑	↑	↑	↑	↑		↑	Min.	(1) Input a 50mV _{p-p} sine wave into Y input. (2) Set the Sharpness control to the minimum. (3) Measure the Y output amplitude at 10kHz [V _{10K}] and 2.4MHz [V _{pK}] and calculate. $G_{SMIN} = 20 \log (V_{pK} / V_{10K})$
8	Sharpness control center characteristic	G _S CT	↑	↑	↑	↑	↑		↑	Adj.	(1) Input a 50mV _{p-p} sine wave into Y input. (2) Set the sharpness control to center (2.5V). (3) Measure the Y output amplitude at 10kHz [V _{10K}] and 2.4MHz [V _{pK}] and calculate. $G_{SCT} = 20 \log (V_{pK} / V_{10K})$
9	Black stretch start point	V _{ST} 1	OFF	↑	OFF	↑	A		↑	Open	(1) Connect the power supply to pin 33. (2) While raising the supply voltage from the voltage obtained in Note 1, measure the variation of voltage on pin 33 and read V _{ST} . (3) Do (2) when the voltage of pin 34 is Note 1's voltage [V _{ST} 1] and Note 1 plus 0.5V [V _{ST} 2].
		V _{ST} 2									
10	Black peak detection period (other than horizontal blanking interval)	T _{BPH}	ON	↑	↑	B	↑		↑	↑	(1) Set Y input and sync. separation input AC GND. (2) Observe the waveform on pin 32.

NOTE	ITEM	SYMBOL	MEASUREMENT CONDITION (V _{CD} -V _{CC} = 12V, T _a = 25 ± 3°C)										MEASUREMENT METHOD	
			SW & VR MODE											
				SW02	SW16	SW17	SW18	SW24	SW25	SW33	VR24	VR25		
11	AC gain	G _v		A	ON	ON	ON	ON	ON	ON	B	Max.	Adj.	(1) Adjust brightness so that the picture-period voltage on pin 12 is 6V. (2) Input a 10kHz, 0.3V _{p-p} sine wave into pin 33. (3) Measure the amplitude on pin 12. (V ₁₂) (4) $G_v = V_{12} (V_{p-p}) / 0.3$
12	Frequency characteristics	G _f		↑	↑	↑	↑	↑	↑	↑	↑	↑	↑	(1) Adjust brightness so that the picture-period voltage on pin 12 is 6V. (2) Input a 0.3V _{p-p} sine wave into pin 33. (3) Adjust sharpness so that the amplitude of Y output for 10kHz input is same as for 2.4MHz input. (4) Measure the amplitude of Y output for 100kHz input [V ₁₂ 100kHz] and for 6MHz input [V ₁₂ 6MHz]. (5) $G_f = 20 \log (V_{12}^{6MHz} + V_{12}^{100kHz})$
13	Contrast adjustment voltage range	ΔV _{ct}		↑	↑	↑	↑	↑	↑	↑	↑	Adj.	↑	(1) Adjust brightness so that the picture-period voltage on pin 12 is 6V. (2) Input a 10kHz, 0.3V _{p-p} sine wave into pin 33. (3) Consider that the maximum contrast is 100% and the minimum contrast is 0%, then measure the difference of contrast control voltage between 10% and 90%.
14	Contrast adjustment center voltage	V _{cto}		↑	↑	↑	↑	↑	↑	↑	↑	↑	↑	(1) Adjust brightness so that the picture-period voltage on pin 12 is 6V. (2) Measure the contrast control voltage for 50%.
15	Brightness adjustment voltage	V _{br}		A	ON	ON	ON	OFF	ON	A	Open	Adj.	(1) Adjust brightness so that the picture-period voltage on pin 12 is 6.8V. (2) Measure the voltage at the brightness terminal.	

NOTE	ITEM	SYMBOL	MEASUREMENT CONDITION (V _{CD} -V _{CC} = 12V, T _a = 25 ± 3°C)										MEASUREMENT METHOD	
			SW & VR MODE											
			SW02	SW16	SW17	SW18	SW24	SW25	SW33	VR24	VR25			
16	Brightness adjustment sensitivity	Gbr		↑	↑	↑	↑	↑	↑	↑	↑	↑	↑	(1) Adjust brightness so that the picture-period voltage on pin 12 is 6.8V. (2) Raise the voltage at the brightness terminal by 1V. (3) Measure the picture-period voltage on pin 12. (V _{12H}) (4) Gbr = (V _{12H} - 6.8)
17	DC restoration	TDC	B	↑	↑	↑	ON	↑	B	Adj.	↑	(1) Adjust brightness so that the picture-period voltage on pin 12 is 6.8V. (2) Input a staircase signal into pins 33 and 36. (3) Adjust contrast so that the amplitude of staircase output from pin 12 is 1.25V. (4) Measure the variation of point A when APL is varied from 10% to 90%.		

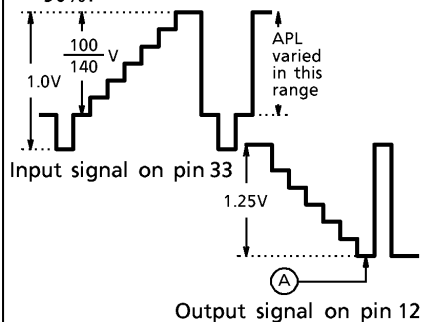

NOTE	ITEM	SYMBOL	MEASUREMENT CONDITION (V _{CD} -V _{CC} = 12V, T _a = 25 ± 3°C)										MEASUREMENT METHOD	
			SW & VR MODE											
			SW02	SW16	SW17	SW18	SW24	SW25	SW33	VR24	VR25			
18	Minimum output	V _{do1}		A	ON	ON	ON	ON	ON	ON	A	Max.	Adj.	(1) Apply 0V to pin 25. (2) Measure the DC voltage (V ₃₀) on pin 30. (3) Apply a DC voltage (V ₃₀) to pin 30. (4) While varying the DC voltage on pin 33, measure the maximum of the picture-period voltage on pin 12. (V _{do2}) (5) Apply 5V to pin 25. (6) Repeat (2) and (3). (7) While varying the DC voltage on pin 33, measure the minimum of the picture-period voltage on pin 12. (V _{do1})
19	Maximum output	V _{do2}												
20	Vertical blanking pulse output level	V _V		B	↑	↑	↑	↑	↑	↑	↑	↑	↑	(1) Adjust brightness so that the picture-period voltage on pin 12 is 6.8V. (2) Measure the voltage of the vertical blanking pulse on pin 12.
21	Sink current during vertical blanking	I _V		↑	↑	↑	↑	↑	↑	↑	↑	↑	↑	(1) Adjust brightness so that the picture-period voltage on pin 12 is 6.8V. (2) Connect pin 12 to GND via 16kΩ. (3) Measure the voltage on pin 12 during vertical blanking interval. (V _{12BLK}) (4) I _V = V _{12BLK} / 16kΩ

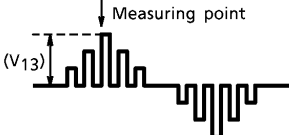
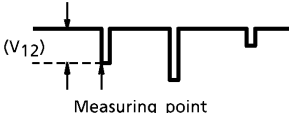
NOTE	ITEM	SYMBOL	MEASUREMENT CONDITION (V _{CD} ·V _{CC} = 12V, T _a = 25 ± 3°C)										MEASUREMENT METHOD	
			SW & VR MODE											
				SW02	SW16	SW17	SW18	SW24	SW25	SW33	VR24	VR25		
22	High bright color gain	GHBC		B	ON	ON	ON	ON	ON	ON	A	Max.	Adj.	(1) Set pin 33 AC GND. (2) Adjust brightness so that the picture-period voltage on pin 12 is 6.8V. (3) Input a rainbow color bar of 0.1V _{p-p} into pin 29. (4) Input a sync. separation pulse into pin 36. (5) Measure the amplitude at the R-Y terminal (pin 13) shown in Figure A. (V ₁₃) (6) Measure the amplitude at the Y output terminal (pin 12) shown in Figure B. (V ₁₂) (7) GH·B·C = (V ₁₂) ÷ (V ₁₃)
													 <p>(Figure A) Output waveform on pin 13</p>  <p>(Figure B) Output waveform on pin 12</p>	
23	OSD output DC voltage	V _{DCY} V _{DCC}		A	ON or OFF	ON or OFF	ON or OFF	OFF	↑	↑	Open	Min.	(1) Apply 1.5V to pin 16. (2) Measure the picture-period voltage on pin 12. (V _{DCY}) (3) Measure the DC voltages on pins 13, 14, and 15. (V _{DCC}) (4) For pin 17 and 18, repeat (1)~(3).	
24	OSD output maximum voltage	V _{OSD} MAX		A	ON or OFF	ON or OFF	ON or OFF	OFF	ON	A	Open	Min.	(1) Apply 12V to pin 1. (2) Apply 5V to pin 16. (3) Measure the DC voltage on pin 13. (V _{OSD} MAX) (4) For pin 17 (measuring at pin 14) and pin 18 (measuring at pin 15), repeat (1)~(3).	
25	OSD mode switching threshold voltage	V _{OSDS} W		↑	↑	↑	↑	↑	↑	↑	↑	↑	(1) Increase the voltage of pin 16 from 0V. (2) Measure the voltage on pin 16 at which the picture-period voltage on pin 12 changes. (3) Measure the voltage on pin 16 at which the DC voltages on pins 13, 14 and 15 change. (4) For pin 17 and pin 18, repeat (1)~(3).	

NOTE	ITEM	SYMBOL	MEASUREMENT CONDITION (V _{CD} -V _{CC} = 12V, T _a = 25 ± 3°C)										MEASUREMENT METHOD
			SW & VR MODE										
			SW02	SW16	SW17	SW18	SW24	SW25	SW33	VR24	VR25		
26	OSD HIGH voltage switching threshold voltage	V _{OSDHIS} W	↑	↑	↑	↑	↑	↑	↑	↑	↑	↑	(1) Decrease the voltage of pin 16 from 5V. (2) Measure the voltage on pin 16 at which the DC voltage on pin 13 changes. (3) For pin 17 (at which voltage on pin 14 changes) and pin 18 (at which voltage on pin 15 changes), repeat (1) and (2).
27	OSD mode switching rise time	τ _{ROSDY} τ _{ROSDC}	A	ON or OFF	ON or OFF	ON or OFF	OFF	ON	A	Open	Adj.	(1) Adjust brightness so that the picture-period voltage on pin 12 is 6.8V. (2) Input the signal in Figure A of 1.4V _{p-p} into pin 16. (3) Measure τ _{ROSDY} , t _{PFOSDY} , τ _{FOSDY} and t _{PFOSDY} on pin 12 according to Figure B. (4) Measure τ _{ROSDC} , t _{PROSDC} , τ _{FOSDC} and t _{PFOSDC} on pins 13, 14 and 15 according to Figure B. (5) In the same way, measure the rise/fall times in (3) and (4) after applying the signal in (2) into pins 17 and 18, respectively.	
28	OSD mode switching rise transfer time	t _{PROSDY} t _{PROSDC}											
29	OSD mode switching fall time	τ _{FOSDY} τ _{FOSDC}											
30	OSD mode switching fall transfer time	t _{PFOSDY} t _{PFOSDC}											
31	OSD HIGH voltage switching rise time	τ _{ROSDHI}	↑	↑	↑	↑	↑	↑	↑	↑	Min.	(1) Input the signal in Figure A of 4.2V _{p-p} into pin 16. (2) Measure τ _{OSDHI} , t _{PROSDHI} , τ _{OSDHI} , and t _{PFOSDHI} on pin 13 according to Figure C. (3) Input the signal in (1) into pin 17. (4) Repeat (2) on pin 14. (5) Input the signal in (1) into pin 18. (6) Repeat (2) on pin 15.	
32	OSD HIGH voltage switching rise transfer time	t _{ROSDHI}											
33	OSD HIGH voltage switching fall time	τ _{FOSDHI}											
34	OSD HIGH voltage switching fall transfer time	t _{PFOSDHI}											

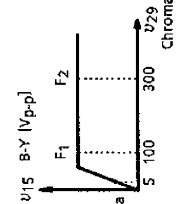
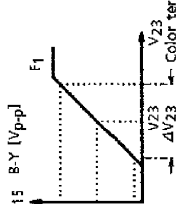
MEASUREMENT CONDITION (VCD, VCC = 12V, Ta = 25 ± 3°C)												
NOTE	ITEM	SYMBOL	SW & VR MODE							MEASUREMENT METHOD		
			SW19	SW22	SW23	SW24	S29a	S29b	VR22		VR23	VR24
35	ACC characteristic	F1 ea A	Open / B	ON	Open	ON	A	A	Variable	—	Max.	<p>(1) Input rainbow color bar into chroma input. (Chroma amplitude is equal burst amplitude.)</p> <p>(2) Adjust tint so that 6th bar of B-Y is the maximum.</p> <p>(3) Measure B-Y amplitude for 5mV_{pp} input with killer off (SW19 : B). [ea]</p> <p>(4) Measure B-Y amplitude for 100 and 300mV_{pp} input.</p> <p>(5) Calculate : A = F1 / F2</p> 
36	Color control characteristic	V23 ΔV23	Open	↑	↑	↑	↑	↑	Variable	↑	<p>(1) Input 100mV_{pp} rainbow color bar into chroma input. (Chroma amplitude is equal burst amplitude.)</p> <p>(2) Adjust tint so that 6th bar of B-Y is the maximum.</p> <p>(3) Adjust color and measure V23 and ΔV23 according to following figure.</p> 	

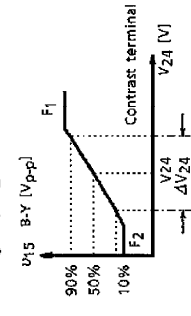
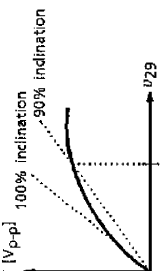
MEASUREMENT CONDITION (VCD, VCC = 12V, Ta = 25 ± 3°C)												
NOTE	ITEM	SYMBOL	SW & VR MODE								MEASUREMENT METHOD	
			SW19	SW22	SW23	SW24	S29a	S29b	VR22	VR23		VR24
37	Contrast control characteristic	V_{24} ΔV_{24} e_u	Open	ON	ON	ON	A	A	Variable	Max.	Variable	<p>(1) Input 100mV_{p-p} rainbow color bar into chroma input.</p> <p>(2) Adjust tint so that 6th bar of B-Y is maximum.</p> <p>(3) Adjust contrast and measure V_{24} and ΔV_{24} according to following figure.</p> <p>(4) Measure F_1 and F_2, then calculate : $e_u = 20 \log (F_1 / F_2)$</p> 
38	Maximum input level	EMAX	Open	ON	Open	ON	A	A	Variable	—	Min.	<p>(1) Input rainbow color bar into chroma input with burst fixed to 500mV_{p-p}.</p> <p>(2) Adjust tint so that 6th bar of B-Y is maximum.</p> <p>(3) While varying chroma amplitude from 200mV_{p-p} to 1.5V_{p-p}, measure EMAX according to following figure.</p> 
39	Killer ON input level	eBK	↑	Open	↑	Open	*	—	—	—	—	<p>(1) Input rainbow color bar into chroma input. (Chroma and burst have same amplitude.)</p> <p>(2) Decreasing input amplitude, then measure the amplitude at which B-Y signal disappears. [eBK]</p>

MEASUREMENT CONDITION (VCD, VCC = 12V, Ta = 25 ± 3°C)														
NOTE	ITEM	SYMBOL	SW & VR MODE											
			SW19	SW22	SW23	SW24	S29a	S29b	VR22	VR23	VR24			
40	APC frequency control sensitivity	β	↑	↑	↑	↑	B	—	—	—	—	—	—	MEASUREMENT METHOD (1) No signal inputted into chroma input. (2) Measure f_0 at pin 21. (3) Measure the pin 20 voltage for f_0 . [V20] (4) Measure the frequency for V20 + 50mV and V20 - 50mV. [f_+ and f_-] (5) Calculate : $\beta = (f_+ - f_-) / 100$
41	APC pull-in/hold range	fPH fPL fHH fHL	Open	Open	Open	*	A	A	—	—	—	—	—	(1) Input 3.58MHz sine wave into chroma input. (2) While bringing chroma frequency close to 3.58MHz from upper and lower side, measure the frequency at which B/W mode turns to color mode. [fPH and fPL] (3) While increasing and decreasing chroma frequency from 3.58MHz, measure the frequency at which color mode turns to B/W mode. [fHH and fHL]
42	Color differential output level	eR eG eB	↑	ON	↑	ON	↑	↑	Variable	↑	↑	Max.	↑	(1) Input 100mVp-p rainbow color bar into chroma input. (2) Adjust tint so that one bar is maximum at R-Y, B-Y and G-Y each. (3) Measure the amplitudes of R-Y, B-Y and G-Y at maximum bars. [eR, eG and eB] Calculate : eR / eB and eG / eB
43	Color differential output relative amplitude	eR / eB eG / eB	↑	↑	↑	↑	A	A	↑	↑	↑	↑	↑	
44	Color differential output relative phase	θ_{R-B} θ_{G-B}	Open	Open	ON	ON	A	A	—	Max.	Variable	Variable	Variable	(1) Input a 100mVp-p, 95° red signal into chroma input. (2) Increase burst phase to make the B-Y waveform flat on pin 15. This phase is θ_B . (3) Decrease burst phase to make the R-Y waveform flat on pin 13. This phase is θ_R . (4) Increase burst phase to make the G-Y waveform flat on pin 14. This phase is θ_G . (5) Calculate : $\theta_{R-B} = \theta_B - \theta_R$ $\theta_{G-B} = 360 - (\theta_G - \theta_B)$

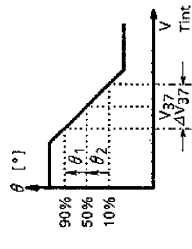
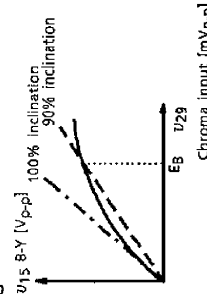
MEASUREMENT CONDITION (V _{CD} , V _{CC} = 12V, T _a = 25 ± 3°C)												
NOTE	ITEM	SYMBOL	SW & VR MODE							MEASUREMENT METHOD		
			SW19	SW22	SW23	SW24	S29a	S29b	VR22		VR23	VR24
45	Tint control characteristic	θ_1 θ_2 θ V_{37} ΔV_{37}	Open	ON	ON	ON	A	A	Variable	Max.	Variable	<p>(1) Input 100mV_{p-p}, 3.58MHz sine wave into chroma input.</p> <p>(2) While varying tint control voltage, measure the B-Y amplitude (AB-Y). And max. of AB-Y is AB-Y^{max}.</p> <p>(3) Calculate : $\chi = AB-Y / AB-Y^{max}$ $\theta = \cos^{-1}\chi$ And draw a following graph of tint control characteristics.</p> <p>(4) Read θ_1, θ_2, V_{37} and ΔV_{37}. And calculate : $\theta = \theta_1 + \theta_2$</p> 
46	Color differential maximum output level	ER EG EB	Open	ON	ON	ON	A	A	Variable	Max.	Max.	<p>(1) Input rainbow color bar into chroma input with its burst fixed 100mV_{p-p}.</p> <p>(2) Adjust tint so that one bar of B-Y at which its amplitude is measured becomes maximum.</p> <p>(3) While varying chroma amplitude, measure the B-Y amplitude on pin 15.</p> <p>(4) Draw a following graph and read EG.</p> <p>(5) For R-Y and G-Y, repeat (2)~(4). These are ER and EG.</p> 

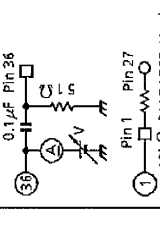
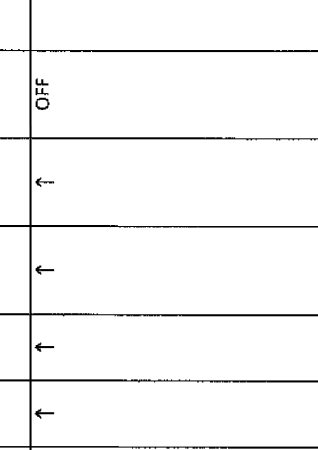
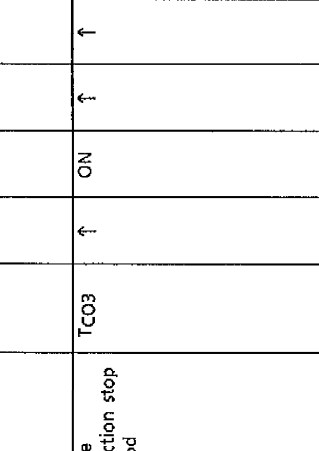
MEASUREMENT CONDITION (VCD, VCC = 12V, Ta = 25 ± 3°C)												
NOTE	ITEM	SYMBOL	SW & VR MODE							MEASUREMENT METHOD		
			SW19	SW22	SW23	SW24	S29a	S29b	VR22		VR23	VR24
47	Residual carrier level	v13e v14e v15e	A	↑	Open	Open	Open	↑	↑	—	—	<p>(1) Input rainbow color bar into chroma input with its burst and chroma 100mV_{p-p}.</p> <p>(2) While adjusting tint, measure the maximum leak from color sub-carrier to color difference output on pin 13, 14 and 15. These are v13e, v14e and v15e.</p>
48	Residual harmonic level	v13He v14He v15He	↑	↑	↑	ON	ON	↑	↑	Max.	Min. Max.	<p>(1) Input rainbow color bar into chroma input with its burst and chroma 100mV_{p-p}.</p> <p>(2) While adjusting tint, measure the maximum residual harmonic level on pin 13, 14 and 15. These are v13He, v14He and v15He.</p>
49	Sync separation input sensitive current	iIN36	ON	ON	OFF	ON	ON	ON	ON	OFF	A	<p>While decreasing V from 3V down, measure the value of I_{DET} at which the frequency of the waveform on pin 1 changes from 297H to 250H.</p> 
50	H.AFC phase detection current	iDET	OFF	OFF	↑	↑	↑	↑	↑	↑	OFF	<p>(1) Measure the DC voltage on pin 3 with no load and then set V to above voltage.</p> <p>(2) Input following signal into pin 36 and observe the pin 3 waveform.</p> <p>(3) Calculate : $I_{DET} = V1 \div 1k\Omega$ [μA]</p> 
51	Phase detection stop period	Tc03	↑	ON	↑	↑	↑	↑	↑	↑	↑	<p>(1) Apply a 60Hz composite video signal to pin 36.</p> <p>(2) Measure the phase det. stop period by pin 3 waveform.</p> 

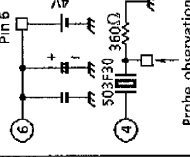
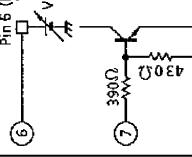
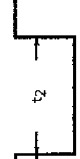
NOTE	ITEM	SYMBOL	MEASUREMENT CONDITION (DEF V _{CC} =9V, T _a = 25 ± 3°C)										MEASUREMENT METHOD
			SW & VR MODE										
			SW1	SW3	SW5	SW6A	SW7A	SW8	SW9	SW10	SW36		
52	32FH VCO oscillation start voltage	VON	↑	↑	↑	OFF	OFF	↑	OFF	↑	B	<p>Check to see that an oscillation waveform (A) appears at pin 4 (32 x fH VCO) when 4V is applied to pin 6 (DEF V_{CC}). (Do not apply V_I/C/OSD V_{CC}.)</p> 	
53	Horizontal output start voltage	VHON	OFF	ON	OFF	OFF	OFF	ON	OFF	OFF	B	<p>While raising V, measure the value of V at which a horizontal pulse (its frequency is 1.5kHz ± 1kHz) is generated from pin 7. (Do not apply V_I/C/OSD V_{CC}.)</p> 	
54	Horizontal free-running frequency	fHO	↑	↑	↑	↑	↑	↑	↑	↑	↑	<p>Measure the oscillation frequency on pin 7 (horizontal output).</p>	
55	Horizontal oscillation frequency variable range	fHMAX fHMIN	↑	↑	↑	↑	↑	↑	↑	↑	↑	<p>Measure the oscillation frequency on pin 7 when pin 3 is connected to H_IV_{CC} via 10kΩ. Measure the oscillation frequency on pin 7 when pin 3 is connected to GND via 68kΩ.</p>	
56	Horizontal oscillation control sensitivity	βH	↑	↑	↑	↑	↑	↑	↑	↑	↑	<p>(1) Measure the voltage on pin 3 at which the horizontal oscillating frequency is 15.734kHz. (2) While varying pin 3 voltage ± 0.05V from above voltage, measure the H osc. frequency. (3) Calculate frequency change rate.</p> <p>While observing the waveform on pin 7, measure t₁ and t₂.</p>  $T7 = \frac{t_1}{t_1 + t_2} \times 100 \quad [\%]$	
58	Horizontal output voltage	VH7 VL7	↑	↑	↑	↑	↑	↑	↑	↑	↑	<p>Measure the HIGH-level voltage of the output waveform on pin 7. Measure the LOW-level voltage of the output waveform on pin 7.</p>	

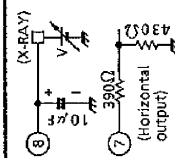
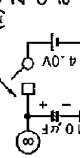
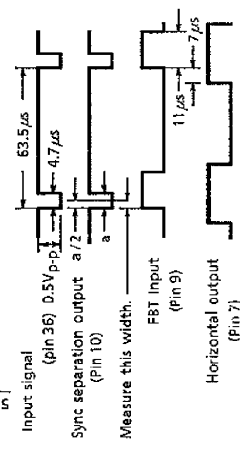
		MEASUREMENT CONDITION (DEF V _{CC} = 9V, T _a = 25 ± 3°C)										MEASUREMENT METHOD	
NOTE	ITEM	SYMBOL	SW & VR MODE										
			SW1	SW3	SW5	SW6A	SW7A	SW8	SW9	SW10	SW36		
59	Overvoltage protection detection voltage	V _{SON}	↑	↑	↑	↑	↑	OFF	↑	↑	↑	↑	 <p>While increasing the pin 8 voltage, measure the voltage at which horizontal output pulse from pin 7 disappears.</p>
60	Overvoltage protection retention voltage	V _{H6}	OFF	ON	OFF	OFF	OFF	OFF	OFF	OFF	B	<p>(1) Apply a voltage of 4V to pin 8 to make H out pulse disappear and then remove the power supply.</p> <p>(2) When setting the pin 6 voltage to 2.5V once, and to 9.0V again, check to see that H out does not appear.</p> 	
61	Horizontal sync phase	SPH _i	↑	↑	↑	ON	ON	ON	ON	ON	OFF	<p>(1) Input a following signal into pin 36.</p> <p>(2) Measure the difference of phase between pin 10's output and FBP.</p> 	

MEASUREMENT CONDITION (DEF VCC = 9V, Ta = 25 ± 3°C)												
NOTE	ITEM	SYMBOL	SW & VR MODE								MEASUREMENT METHOD	
			SW1	SW3	SW5	SW6A	SW7A	SW8	SW9	SW10		SW36
62	Gate pulse start phase	GP1	↑	↑	↑	↑	↑	↑	↑	↑	↑	<p>(1) Input a following signal into pin 36.</p> <p>(2) Measure the difference of phase between pin 10 and pin 19 and pulse width on pin 19.</p> <p>Input signal (Signal generator) 0.5V_{p-p}</p> <p>Sync separation output (Pin 10)</p> <p>Killer (Pin 19)</p> <p>GP1</p> <p>GP2</p> <p>63.5µs</p> <p>4.7µs</p>
63	Gate pulse width	GP2										<p>63.5µs</p>
64	Horizontal screen phase adjustment variable range	ΔG5	OFF	ON	ON	ON	ON	ON	ON	ON	OFF	<p>(1) Same as Note 63's (1).</p> <p>(2) While varying VRDS from minimum to maximum, measure the change of FBP phase.</p> <p>Sync separation output (Pin 10)</p> <p>63.5µs</p> <p>VRDS when at minimum (GND)</p> <p>VRDS when at maximum (DEF VCC)</p> <p>FBP pulse input (Pin 9)</p> <p>ΔG5</p>
65	Vertical free-running frequency	f _{vo}	ON	↑	OFF	↑	↑	↑	↑	OFF	B	<p>0.1µF</p> <p>Pin 36</p> <p>Pin 27</p> <p>10kΩ (V/C/OSD VCC)</p> <p>Measure the oscillation frequency on pin 1.</p>

MEASUREMENT CONDITION (H.VCC = 9V, Ta = 25 ± 3°C)													
NOTE	ITEM	SYMBOL	SW & VR MODE										
			SW1	SW3	SW5	SW6A	SW7A	SW8	SW9	SW10	SW36		
66	Vertical output pulse width	Tr1	↑	↑	↑	↑	↑	↑	↑	↑	↑	OFF	<p>10kΩ Pin 27 (V1C/OSD VCC) 10kΩ Pin 36 Open</p> <p>Measure Tr1 from the waveform on pin 1.</p>
			↑	↑	↑	↑	↑	↑	↑	↑	↑	↑	
67		Tr2	↑	↑	↑	↑	↑	↑	↑	↑	↑	↑	<p>10kΩ Pin 36</p> <p>Measure Tr2 from the waveform on pin 1.</p>
68	Vertical pull-in range	fpV1	↑	↑	↑	↑	↑	↑	↑	↑	↑	↑	<p>Measure Tr2 from the waveform on pin 1.</p> <p>(1) Input a 60Hz composite video signal into pin 36 (sync. separation input). (2) While varying the vertical frequency in 0.5H steps, measure the vertical pull-in range.</p>
		fpV2	↑	↑	↑	↑	↑	↑	↑	↑	↑	↑	

TEST CIRCUIT1.
Video section

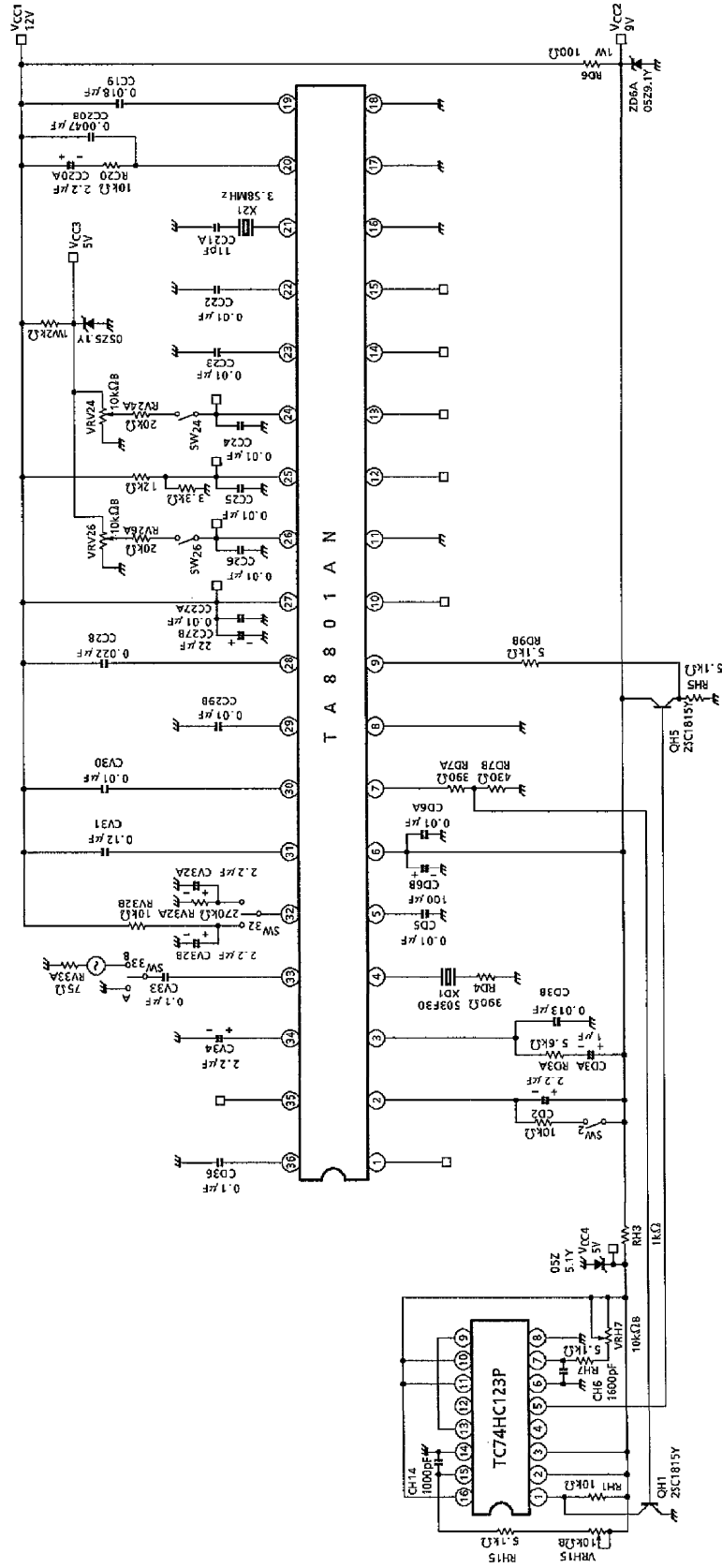

TEST CIRCUIT2.
OSD section

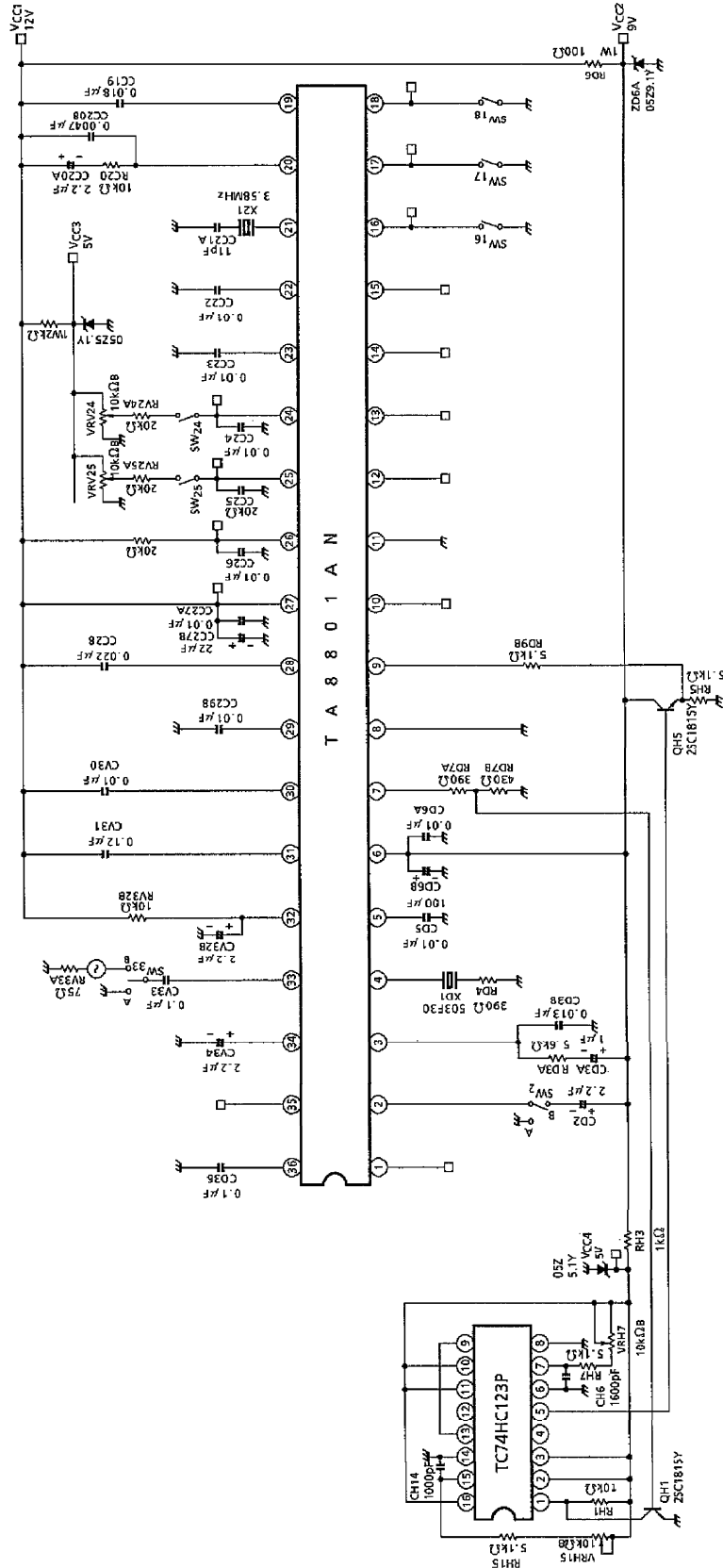

TEST CIRCUITS.
Chroma section

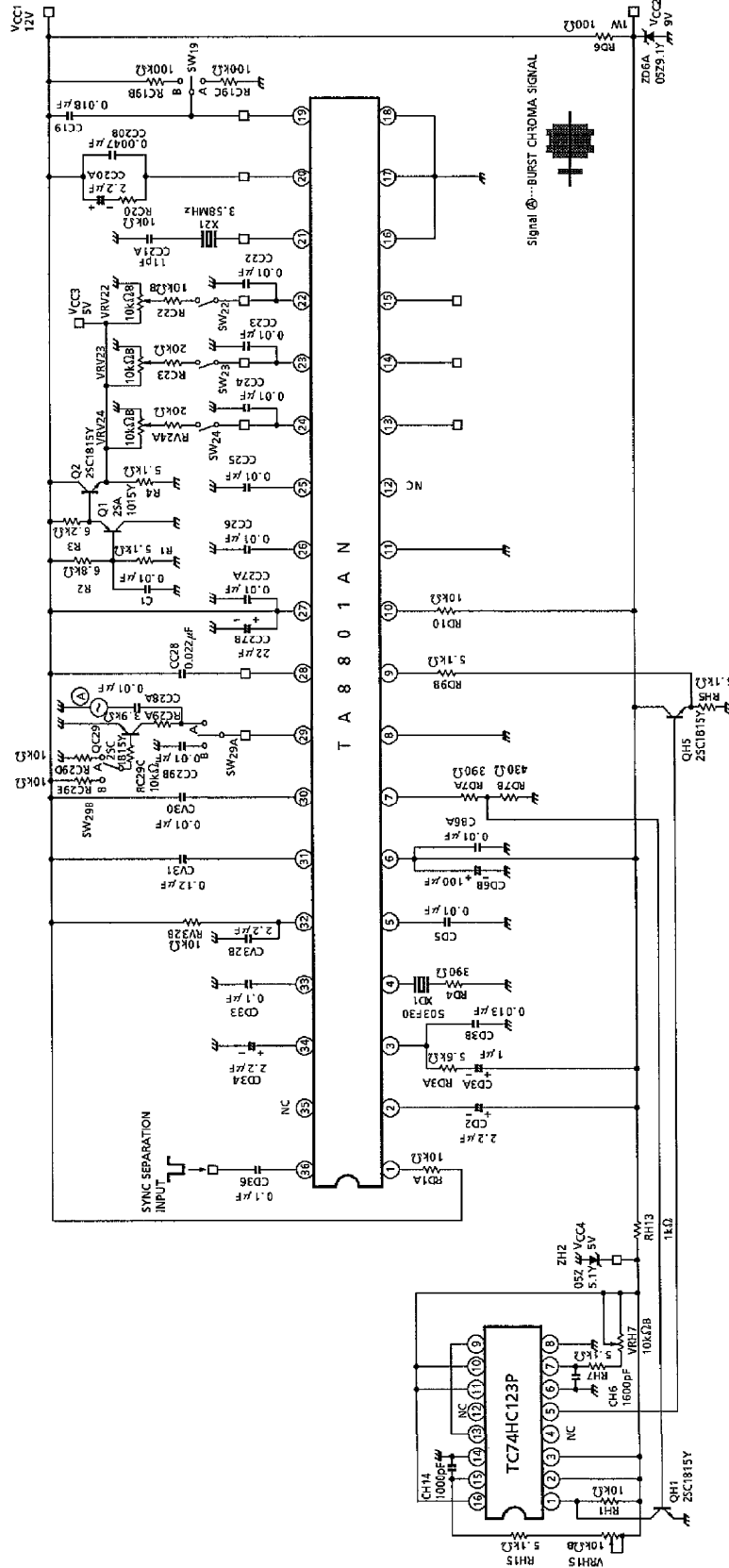

TEST CIRCUIT4.

Deflection section

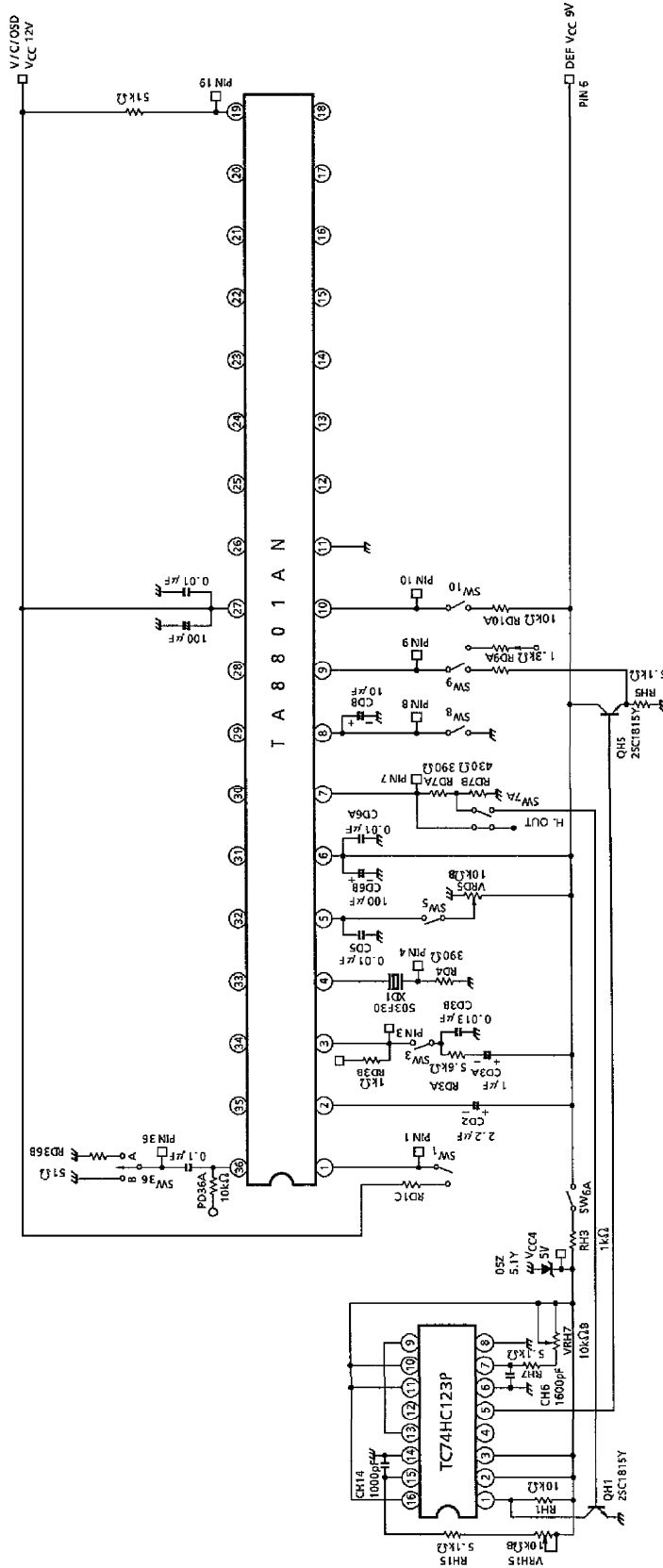

SIGNAL FOR MEASUREMENT

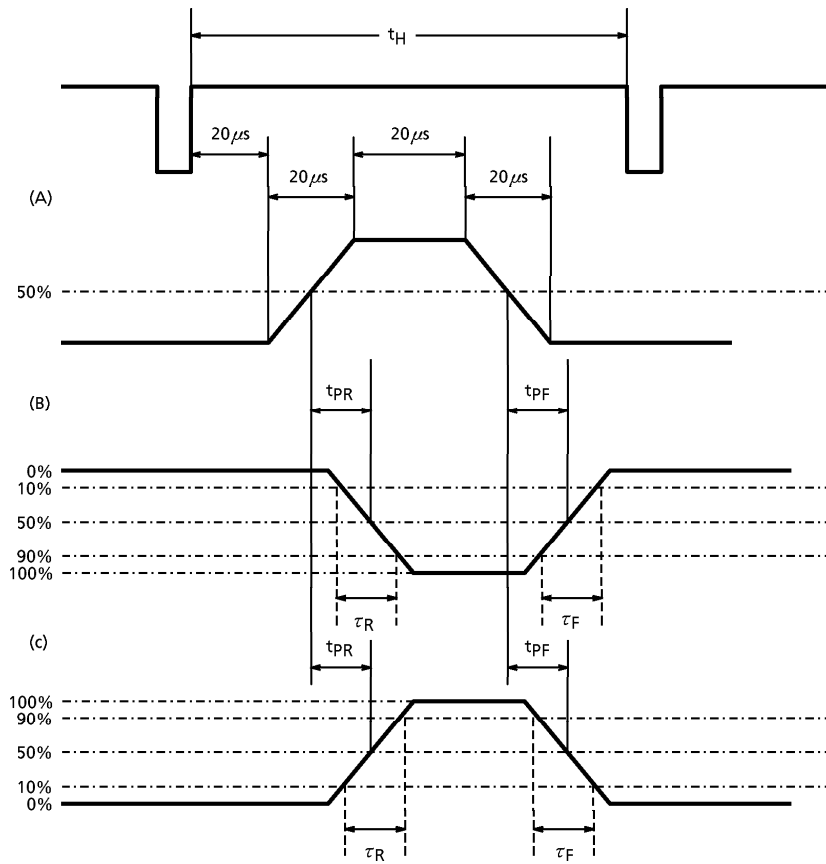

APPLICATION CIRCUIT

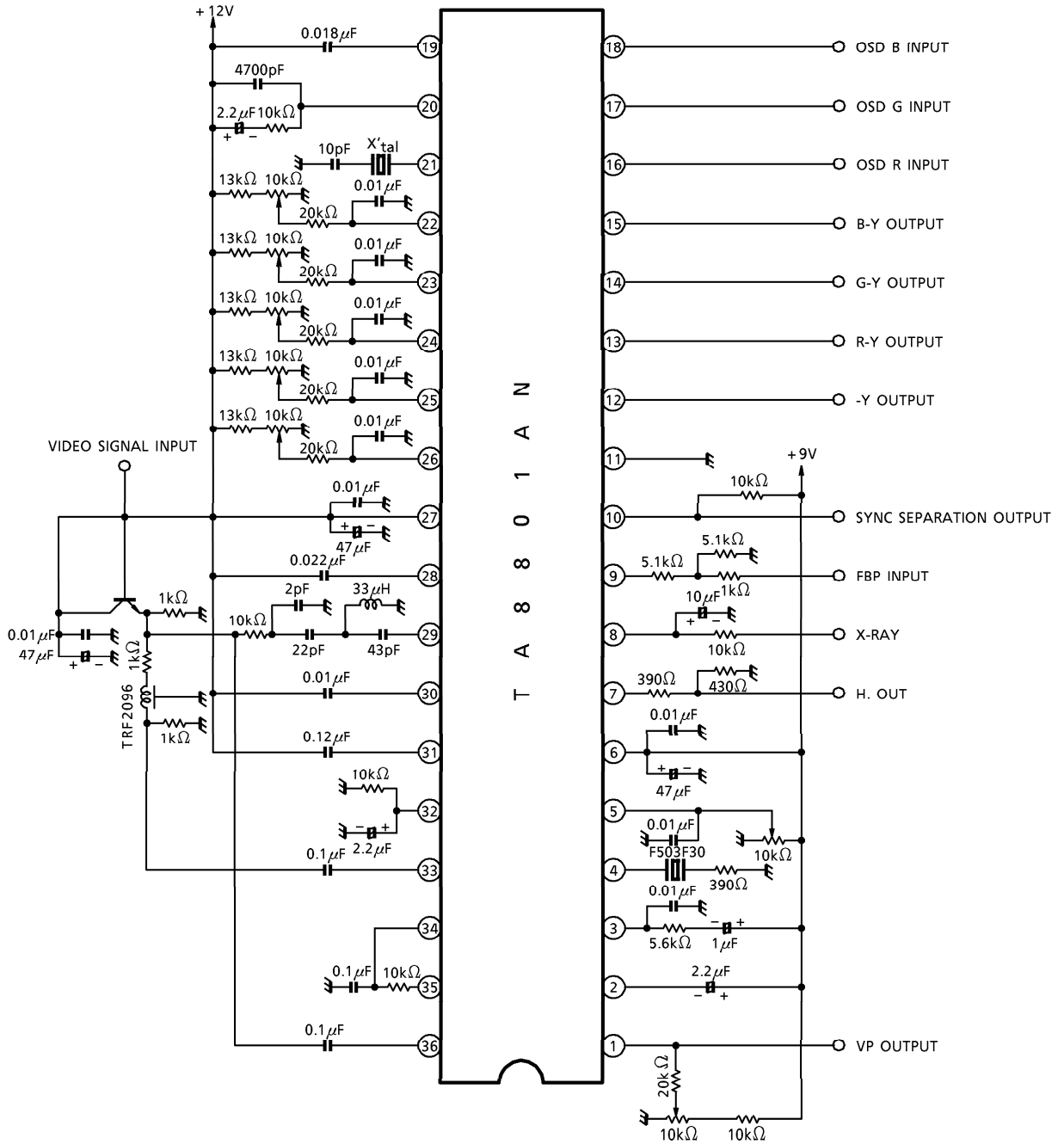

OUTLINE DRAWING
SDIP36-P-500-1.78

Unit : mm

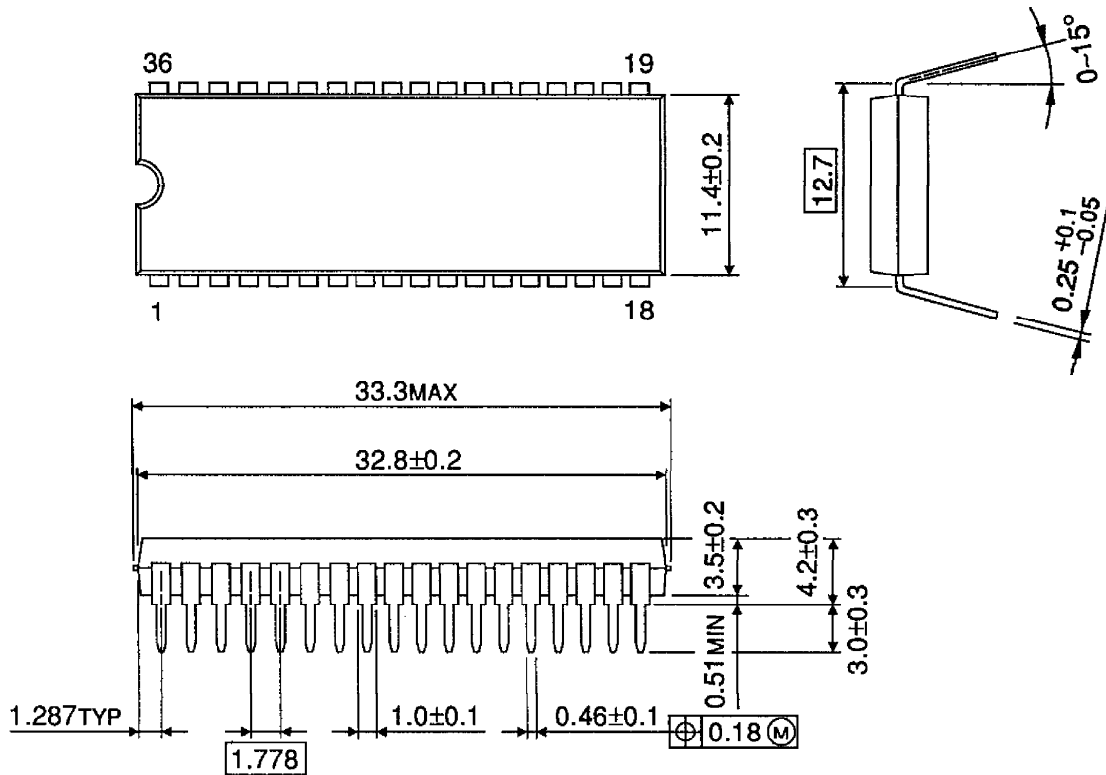

Weight : 2.98g (Typ.)