



# DS1603 Elapsed Time Counter Module

www.dalsemi.com

## FEATURES

- Two 32-bit counters keep track of real time and elapsed time
- Counters keep track of seconds for over 125 years
- Battery powered counter counts seconds from the time battery is attached until  $V_{BAT}$  is less than 2.5 volts
- $V_{CC}$  powered counter counts seconds while  $V_{CC}$  is above 4.25 volts and retains the count in the absence of  $V_{CC}$  under battery backup power
- Clear function resets selected counter to 0
- Read/Write serial port affords low pin count
- Powered internally by a lithium energy cell that provides over 10 years of operation
- 1-byte protocol defines read/write, counter address and software clear function
- Self-contained crystal provides an accuracy of  $\pm 2$  min per month
- Operating temperature range of  $0^{\circ}C$  to  $70^{\circ}C$
- Low profile SIP module

## DESCRIPTION

The DS1603 is a real time clock/elapsed time counter designed to count seconds when  $V_{CC}$  power is applied and continually count seconds under battery backup power with an additional counter regardless of the condition of  $V_{CC}$ . The continuous counter can be used to derive time of day, week, month, and year by using a software algorithm. The  $V_{CC}$  powered counter will automatically record the amount of time that  $V_{CC}$  power is applied. This function is particularly useful in determining the operational time of equipment in which the DS1603 is used. Alternatively, this counter can also be used under software control to record real time events. Communication to and from the DS1603 takes place via a 3-wire serial port. A 1-byte protocol selects read/write functions, counter clear functions and oscillator trim. The device contains a 32.768 kHz crystal which will keep track of time to within  $\pm 2$  min/mo. An internal lithium energy source contains enough energy to power the continuous seconds counter for over 10 years.

## OPERATION

The main elements of the DS1603 are shown in Figure 1. As shown, communications to and from the elapsed time counter occur over a 3-wire serial port. The port is activated by driving  $RST$  to a high state.

With  $RST$  at high level 8 bits are loaded into the protocol shift register providing read/write, register select, register clear, and oscillator trim information. Each bit is serially input on the rising edge of the

## PIN ASSIGNMENT

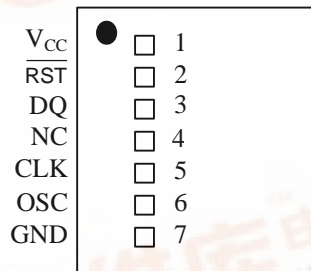

## PIN DESCRIPTION

$RST$	- Reset
CLK	- Clock
DQ	- Data Input/Output
GND	- Ground
$V_{CC}$	- +5 Volts
OSC	- 1 Hz Oscillator Output
NC	- No Connect



clock input. After the first eight clock cycles have loaded the protocol register with a valid protocol additional clocks will output data for a read or input data for a write.  $V_{CC}$  must be present to access the DS1603. If  $V_{CC} <$  the internal power supply (approximately 3.0 volts) the DS1603 will switch to internal power and disable the serial port to conserve energy. When running off of the internal power supply, only the continuous counter will continue to count and the counter powered by  $V_{CC}$  will stop, but retain the count which had accumulated when  $V_{CC}$  power was lost.

## PROTOCOL REGISTER

The protocol bit definition is shown in Figure 2. Valid protocols and the resulting actions are shown in Table 1. Each data transfer to the protocol register designates what action is to occur. As defined, the MSB (bit 7 which is designated ACC) selects the 32-bit continuous counter for access. If ACC is a logical 1 the continuous counter is selected and the 32 clock cycles that follow the protocol will either read or write this counter. If the counter is being read, the contents will be latched into a different register at the end of protocol and the latched contents will be read out on the next 32 clock cycles. This avoids reading garbled data if the counter is clocked by the oscillator during a read. Similarly, if the counter is to be written, the data is buffered in a register and all 32 bits are jammed into the counter simultaneously on the rising edge of the 32<sup>nd</sup> clock. The next bit (bit 6 which is designated AVC) selects the 32-bit  $V_{CC}$  active counter for access. If AVC is a logical 1 this counter is selected and the 32 clock cycles that follow will either read or write this counter. If both bit 7 and bit 6 are written to a logic high, all clock cycles beyond the protocol are ignored and bit 5, 4, and 3 are loaded into the oscillator trim register. A value of binary 3 (011) will give a clock accuracy of  $\pm 120$  seconds per month at 25°C. Increasing the binary number towards 7 will cause the real time clock to run faster. Conversely, lowering the binary number towards 0 will cause the clock to run slower. Binary 000 will stop the oscillator completely. This feature can be used to conserve battery life during storage. In this mode the internal power supply current is reduced to 100 nA maximum. In applications where oscillator trimming is not practical or not needed, a default setting of 011 is recommended. Bit 2 of protocol (designated CCC) is used to clear the continuous counter. When set to logic 1, the continuous counter will reset to 0 when  $\overline{RST}$  is taken low. Bit 1 of protocol (designated CVC) is used to clear the  $V_{CC}$  active counter. When set to logical 1, the  $V_{CC}$  active counter will reset to 0 when  $\overline{RST}$  is taken low. Both counters can be reset simultaneously by setting CCC and CVC both to a logical 1. Bit 0 of the protocol (designated RD) determines whether the 32 clocks to follow will write a counter or read a counter. When RD is set to a logical 0 a write action will follow when RD is set to a logical 1 a read action will follow. When sending the protocol, 8 bits should always be sent. Sending less than 8 bits can produce erroneous results. If clearing the counters or trimming the oscillator, the data transfer can be terminated after the 8-bit protocol is sent. However, when reading or writing the counters, 32 clock cycles should always follow the protocol.

## RESET AND CLOCK CONTROL

All data transfers are initiated by driving the  $\overline{RST}$  input high. The  $\overline{RST}$  input has two functions. First,  $\overline{RST}$  turns on the serial port logic which allows access to the protocol register for the protocol data entry. Second, the  $\overline{RST}$  signal provides a method of terminating the protocol transfer or the 32-bit counter transfer. A clock cycle is a sequence of a falling edge followed by a rising edge. For write inputs, data must be valid during the rising edge of the clock. Data bits are output on the falling edge of the clock when data is being read. All data transfers terminate if the  $\overline{RST}$  input is transitioned low and the DQ pin goes to a high impedance state.  $\overline{RST}$  should only be transitioned low while the clock is high to avoid disturbing the last bit of data. All data transfers must consist of 8 bits when transferring protocol only or 8 + 32 bits when reading or writing either counter. Data transfer is illustrated in Figure 3.

## DATA INPUT

Following the 8-bit protocol that inputs write mode, 32 bits of data are written to the selected counter on the rising edge of the next 32 CLK cycles. After 32 bits have been entered any additional CLK cycles will be ignored until  $\overline{\text{RST}}$  is transitioned low to end data transfer and then high again to begin new data transfer.

## DATA OUTPUT

Following the eight CLK cycles that input read mode protocol, 32 bits of data will be output from the selected counter on the next 32 CLK cycles. The first data bit to be transmitted from the selected 32-bit counter occurs on the falling edge after the last bit of protocol is written. When transmitting data from the selected 32-bit counter,  $\overline{\text{RST}}$  must remain at high level as a transition to low level will terminate data transfer. Data is driven out the DQ pin as long as CLK is low. When CLK is high the DQ pin is tristated.

## OSCILLATOR OUTPUT

Pin 6 of the DS1603 module is a 1 Hz output signal. This signal is present only when  $V_{CC}$  is applied and greater than the internal power supply. However, the output is guaranteed to meet TTL requirement only while  $V_{CC}$  is within normal limits. This output can be used as a 1-second interrupt or time tick needed in some applications.

## INTERNAL POWER

The internal battery of the DS1603 module provides 35 mAh and will run the elapsed time counter for over 10 years in the absence of power.

## DS1603 ELAPSED TIME COUNTER BLOCK DIAGRAM Figure 1

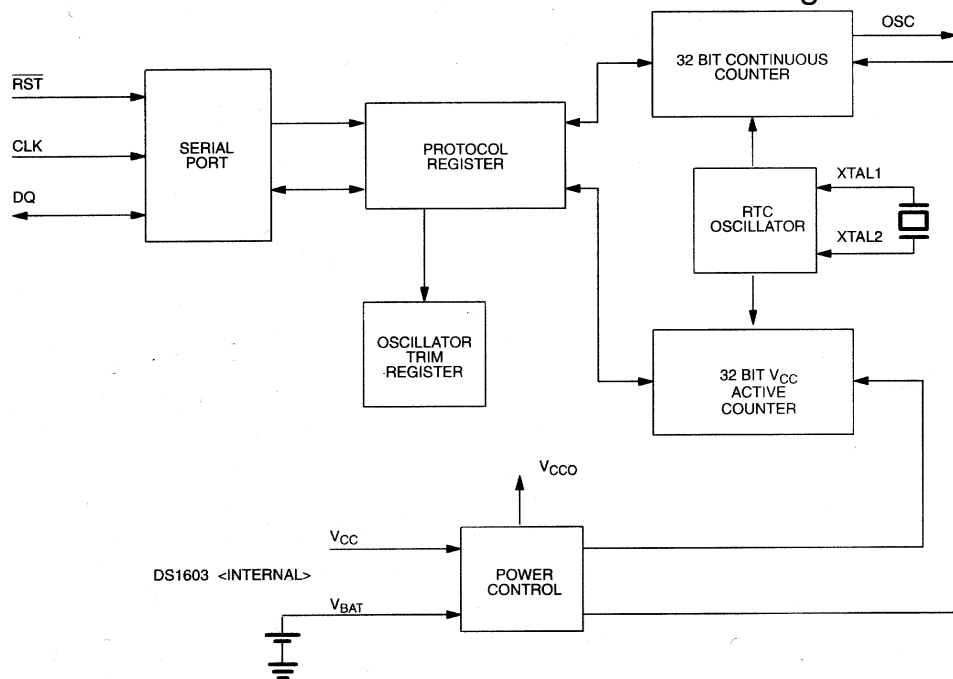

## PROTOCOL BIT MAP Figure 2

7	6	5	4	3	2	1	0
ACC	AVC	OSC2	OSC1	OSC0	CCC	CVC	RD

**VALID PROTOCOLS Table 1**

ACTION	PROTOCOL								DESCRIPTION
	ACC	AVC	OSC2	OSC1	OSC0	CCC	CVC	RD	
Read Continuous Counter	1	0	X	X	X	X	X	1	Output continuous counter on the 32 clocks following protocol. Oscillator trim register is not updated. Counters are not reset.
Write Continuous Counter	1	0	X	X	X	X	X	0	Input data to continuous counter on the 32 clocks following protocol. Oscillator trim register is not updated. Counters are not reset.
Read V <sub>CC</sub> Active Counter	0	1	X	X	X	X	X	1	Output V <sub>CC</sub> active counter on the 32 clocks following protocol, oscillator trim register is not updated. Counters are not reset.
Write V <sub>CC</sub> Active Counter	0	1	X	X	X	X	X	0	Input data to continuous counter on the 32 clocks following protocol. Oscillator trim register is not updated. Counters are not reset.
Clear Continuous Counter	0	0	X	X	X	1	X	X	Resets the continuous counter to all zeroes at the end of protocol. Oscillator trim register is not updated.
Clear V <sub>CC</sub> Active Counter	0	0	X	X	X	X	1	X	Resets the V <sub>CC</sub> active counter to all zeroes at the end of protocol. Oscillator trim register is not updated.
Set Oscillator Trim Bits	1	1	A	B	C	X	X	0	Sets the oscillator trim register to a value of ABC. Counters are unaffected.

X = Don't Care

### DATA TRANSFER Figure 3

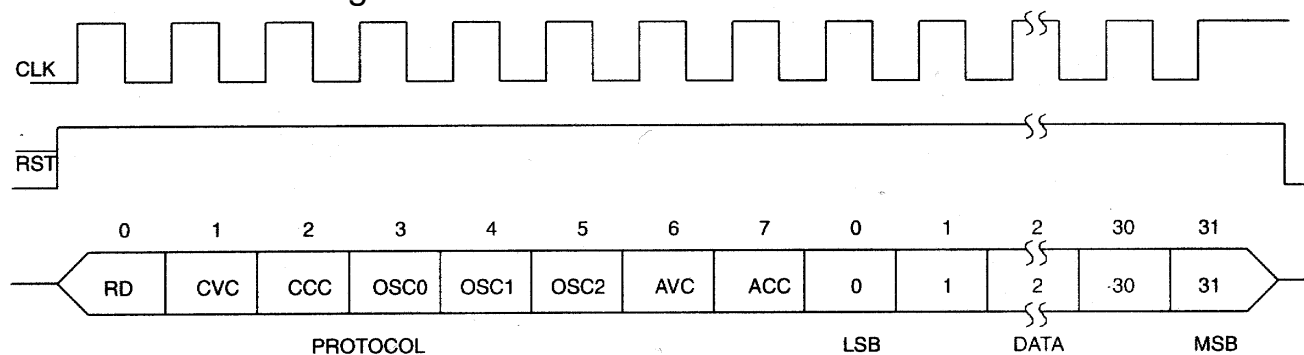

### TIMING DIAGRAM: READ/WRITE DATA TRANSFER

#### READ DATA TRANSFER

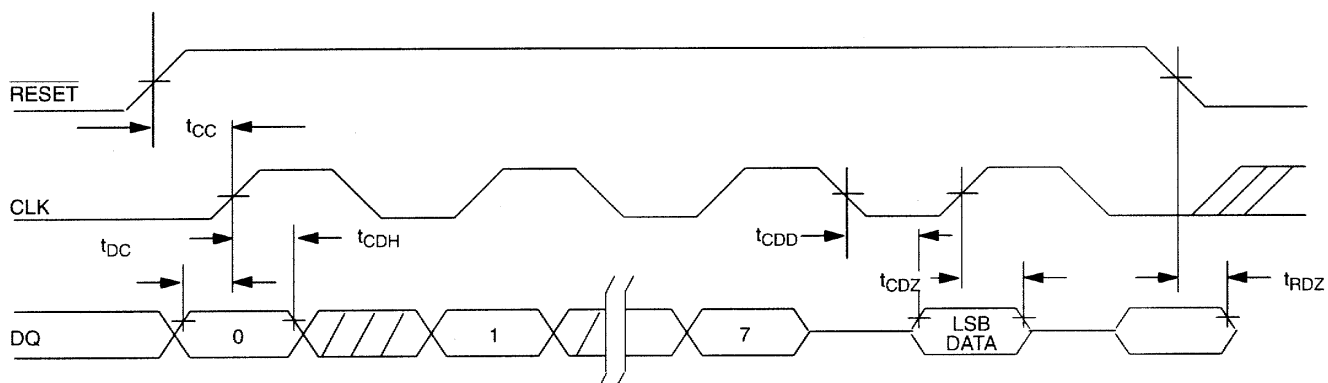

#### WRITE DATA TRANSFER

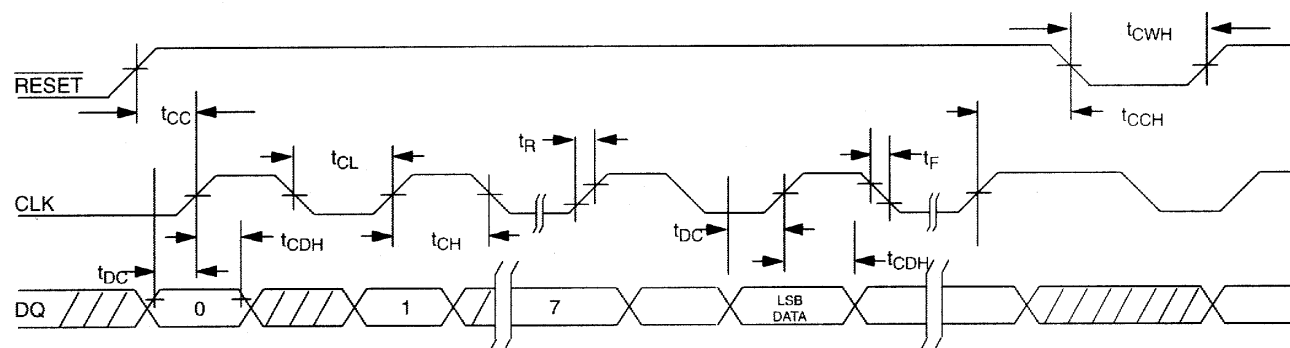

NOTE:  $t_{CL}$ ,  $t_{CH}$ ,  $t_R$ , and  $t_F$  apply to both read and write data transfer.

**ABSOLUTE MAXIMUM RATINGS\***

Voltage on Any Pin Relative to Ground	-0.3V to +7.0V
Operating Temperature	0°C to 70°C
Storage Temperature	-40°C to +70°C
Soldering Temperature	260°C for 10 seconds (See Note 11)

\* This is a stress rating only and functional operation of the device at these or any other conditions above those indicated in the operation sections of this specification is not implied. Exposure to absolute maximum rating conditions for extended periods of time may affect reliability.

**RECOMMENDED DC OPERATING CONDITIONS** (0°C to 70°C)

PARAMETER	SYMBOL	MIN	TYP	MAX	UNITS	NOTES
Supply Voltage	$V_{CC}$	4.5	5.0	5.5	V	1
Logic 1 Input	$V_{IH}$	2.0		$V_{CC}+0.3$	V	1
Logic 0 Input	$V_{IL}$	-0.3		0.8	V	1

**DC ELECTRICAL CHARACTERISTICS** (0°C to 70°C;  $V_{CC} = 5V \pm 10\%$ )

PARAMETER	SYMBOL	MIN	TYP	MAX	UNITS	NOTES
Input Leakage	$I_{LI}$	-1		+1	$\mu A$	
I/O Leakage	$I_{LO}$	-1		+1	$\mu A$	
Logic 1 Output	$V_{OH}$	2.4			V	2
Logic 0 Output	$V_{OL}$			0.4	V	3
Active Supply Current	$I_{CC}$			1	mA	4
Timekeeping Current	$I_{CC1}$			50	$\mu A$	5
Battery Trip Point	$V_{TP}$	2.2		3.7	V	9

**CAPACITANCE** ( $t_A = 25^\circ C$ )

PARAMETER	SYMBOL	MIN	TYP	MAX	UNITS	NOTES
Input Capacitance	$C_I$		5		pF	
I/O Capacitance	$C_{IO}$		10		pF	

**AC ELECTRICAL CHARACTERISTICS** ( $V_{CC} = +5V \pm 10\%$ ;  $0^{\circ}C$  to  $+70^{\circ}C$ )

PARAMETER	SYMBOL	MIN	TYP	MAX	UNITS	NOTES
Data to CLK Setup	$t_{DC}$	50			ns	6
CLK to Data Hold	$t_{CDH}$	60			ns	6
CLK to Data Delay	$t_{CDD}$			200	ns	6, 7, 8
CLK Low Time	$t_{CL}$	250			ns	6
CLK High Time	$t_{CH}$	250			ns	6
CLK Frequency	$f_{CLK}$	DC		2.0	MHz	6
CLK Rise & Fall	$t_F, t_R$			500	ns	
$\overline{RST}$ to CLK Setup	$t_{CC}$	100			ns	6
CLK to $\overline{RST}$ Hold	$t_{CCH}$	60			ns	6
$\overline{RST}$ Inactive Time	$t_{CWH}$	1			$\mu s$	6
$\overline{RST}$ Low to I/O High Z	$t_{RDZ}$			70	ns	6
CLK High to I/O High Z	$t_{CDZ}$			20	ns	6

 $(t_A = 25^{\circ}C)$ 

PARAMETER	SYMBOL	MIN	TYP	MAX	UNITS	NOTES
Expected Data Retention Time	$t_{DR}$	10			years	10

**NOTES:**

- All voltages are reference to ground.
- Logic 1 voltages are specified at a source current of 1 mA.
- Logic 0 voltages are specified at a sink current of 4 mA.
- $I_{CC}$  is specified with the DQ pin open.
- $I_{CC1}$  is specified with  $V_{CC}$  at 5.0V and  $\overline{RST} = GND$ .
- Measured at  $V_{IH} = 2.0V$  or  $V_{IL} = 0.8V$ .
- Measured at  $V_{OH} = 2.4V$  or  $V_{OL} = 0.4V$ .
- Load capacitance = 50 pF.
- Battery trip point is the point at which the  $V_{CC}$  powered counter and the serial port stop operation.
- The expected  $t_{DR}$  is defined as accumulative time in the absence of  $V_{CC}$  with the clock oscillator running.
- Real-Time Clock Modules can be successfully processed through conventional wave-soldering techniques as long as temperature exposure to the lithium energy source contained within does not exceed  $+85^{\circ}C$ . Post-solder cleaning with water washing techniques is acceptable, provided that ultrasonic vibration is not used.

## DS1603 7-PIN MODULE

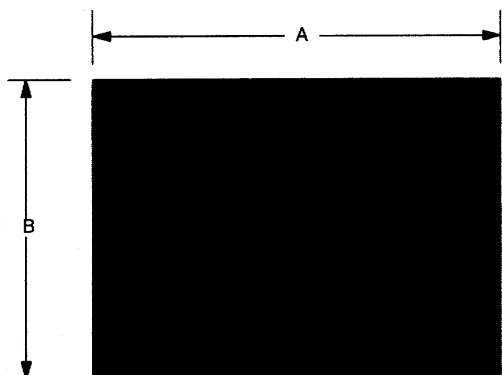

PKG	7-PIN	
DIM	MIN	MAX
A IN.	0.830	0.850
MM	21.08	21.59
B IN.	0.650	0.670
MM	16.51	17.02
C IN.	0.310	0.330
MM	7.87	8.38
D IN.	0.015	0.030
MM	0.38	0.76
E IN.	0.110	0.140
MM	2.79	3.56
F IN.	0.015	0.021
MM	0.38	0.53
G IN.	0.090	0.110
MM	2.29	2.79
H IN.	0.105	0.135
MM	2.67	3.43
J IN.	0.360	0.390
MM	9.14	9.91

