

TOSHIBA CMOS DIGITAL INTEGRATED CIRCUIT SILICON MONOLITHIC

TC74HC153AP, TC74HC153AF, TC74HC153AFN
TC74HC253AP, TC74HC253AF, TC74HC253AFN

TC74HC153AP / AF / AFN DUAL 4 - CHANNEL MULTIPLEXER
TC74HC253AP / AF / AFN DUAL 4 - CHANNEL MULTIPLEXER WITH 3 - STATE OUTPUT

(Note) The JEDEC SOP (FN) is not available in Japan.

The TC74HC153A and TC74HC253A are high speed CMOS DUAL 4 - CHANNEL MULTIPLEXERS fabricated with silicon gate C²MOS technology.

They achieve the high speed operation similar to equivalent LSTTL while maintaining the CMOS low power dissipation.

The TC74HC153A has standard outputs, while the TC74HC253A has 3 - state outputs.

Input data (1C0 ~ 1C2, 2C0 ~ 2C3) are selected by the two address inputs, A and B.

Separate strobe inputs (1G, 2G) are provided for each of the two four - line sections. They can be used to inhibit the data outputs. The output of the HC153A is set low, and the HC253A output is set to the high impedance state, when the strobe inputs are low.

All inputs are equipped with protection circuits against static discharge or transient excess voltage.

FEATURES :

- High Speed..... $t_{pd} = 12ns(\text{typ.})$ at $V_{CC} = 5V$
- Low Power Dissipation..... $I_{CC} = 4\mu A(\text{Max.})$ at $T_a = 25^\circ C$
- High Noise Immunity..... $V_{NIH} = V_{NIL} = 28\% V_{CC} (\text{Min.})$
- Output Drive Capability..... 10 LSTTL Loads
- Symmetrical Output Impedance... $| I_{OH} | = I_{OL} = 4mA(\text{Min.})$
- Balanced Propagation Delays..... $t_{pLH} \approx t_{pHL}$
- Wide Operating Voltage Range... $V_{CC} (\text{opr.}) = 2V \sim 6V$
- Pin and Function Compatible with 74LS153, 74LS253

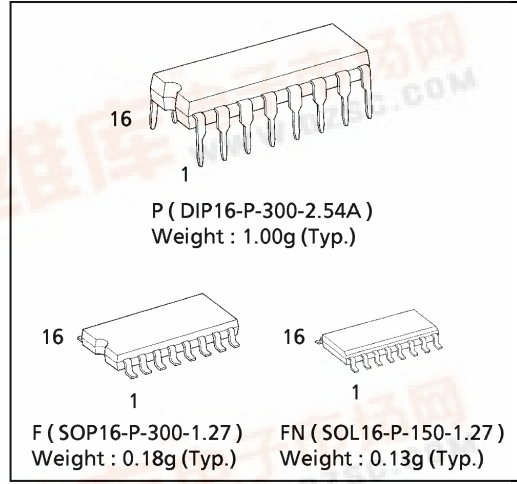

PIN ASSIGNMENT

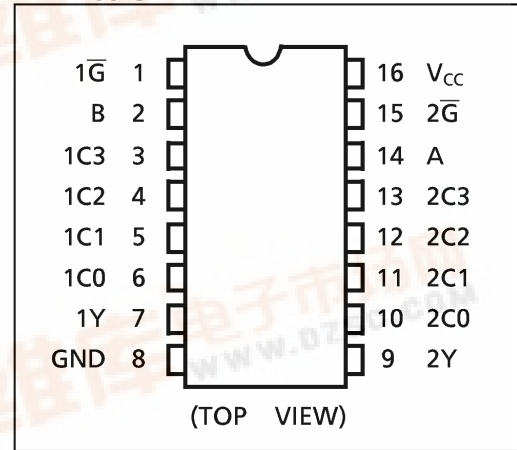

IEC LOGIC SYMBOL

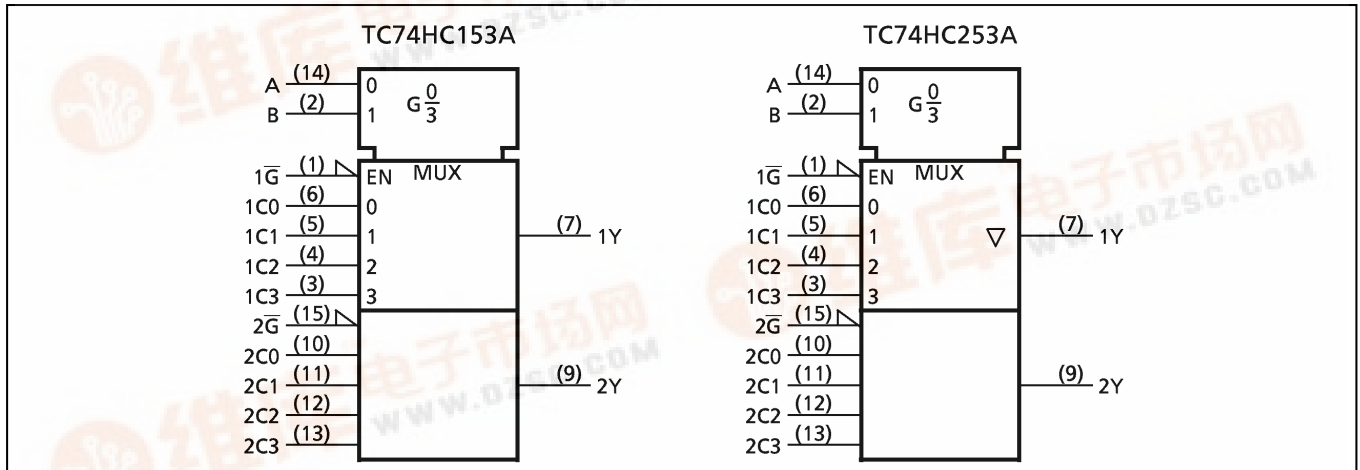

980508EBA2

● TOSHIBA is continually working to improve the quality and the reliability of its products. Nevertheless, semiconductor devices in general can malfunction or fail due to their inherent electrical sensitivity and vulnerability to physical stress. It is the responsibility of the buyer, when utilizing TOSHIBA products, to observe standards of safety, and to avoid situations in which a malfunction or failure of a TOSHIBA product could cause loss of human life, bodily injury or damage to property. In developing your designs, please ensure that TOSHIBA products are used within specified operating ranges as set forth in the most recent products specifications. Also, please keep in mind the precautions and conditions set forth in the TOSHIBA Semiconductor Reliability Handbook.



SYSTEM DIAGRAM

SELECT INPUTS		DATA INPUTS				STROBE	OUTPUT Y	
B	A	C0	C1	C2	C3	\bar{G}	HC153A	HC253A
X	X	X	X	X	X	H	L	Z
L	L	L	X	X	X	L	L	L
L	L	H	X	X	X	L	H	H
L	H	X	L	X	X	L	L	L
L	H	X	H	X	X	L	H	H
H	L	X	X	L	X	L	L	L
H	L	X	X	H	X	L	H	H
H	H	X	X	X	L	L	L	L
H	H	X	X	X	H	L	H	H

X : Don't Care
Z : High Impedance

SYSTEM DIAGRAM

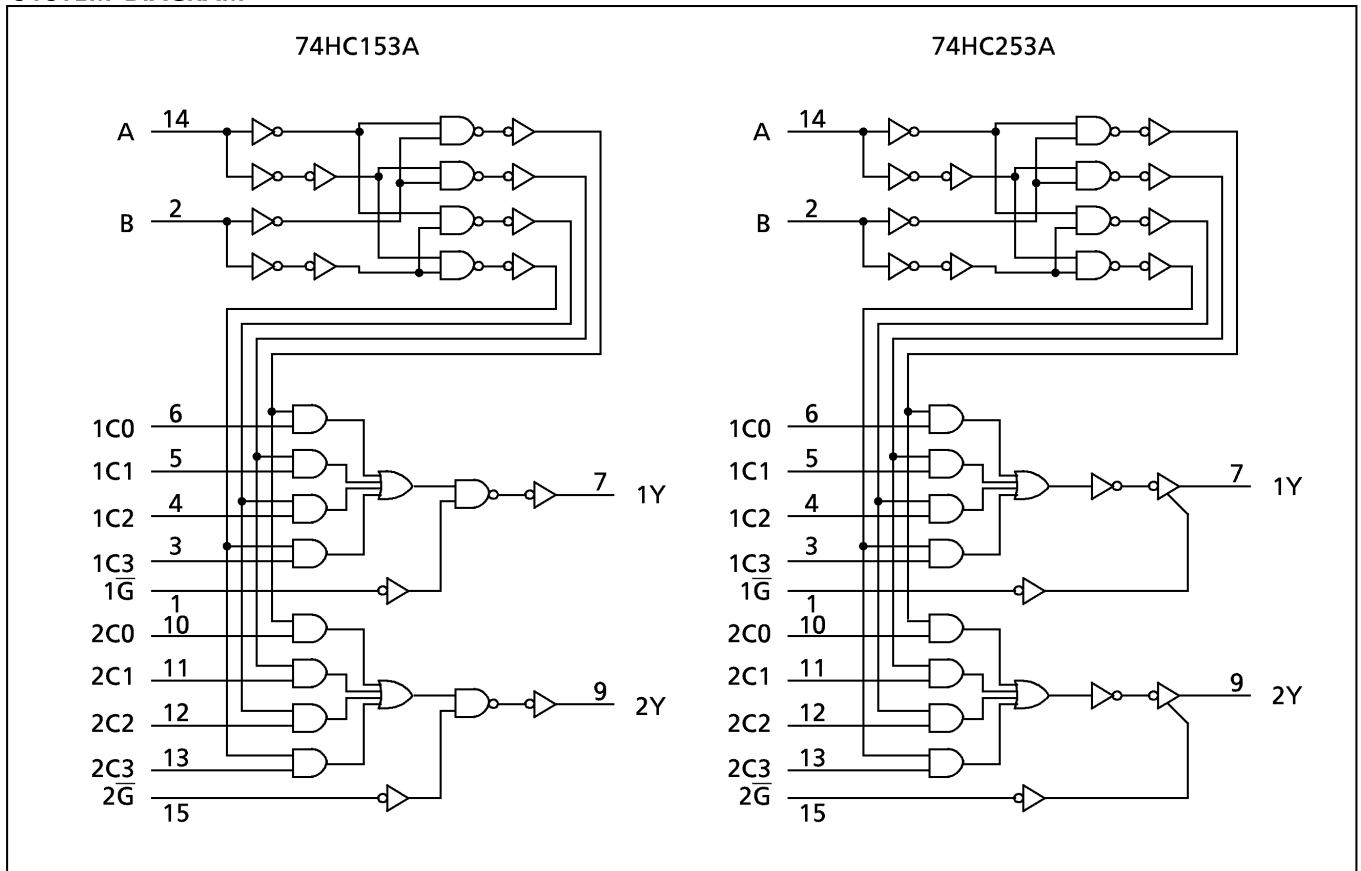

980508EBA2'

- The products described in this document are subject to foreign exchange and foreign trade laws.
- The information contained herein is presented only as a guide for the applications of our products. No responsibility is assumed by TOSHIBA CORPORATION for any infringements of intellectual property or other rights of the third parties which may result from its use. No license is granted by implication or otherwise under any intellectual property or other rights of TOSHIBA CORPORATION or others.
- The information contained herein is subject to change without notice.

ABSOLUTE MAXIMUM RATINGS

PARAMETER	SYMBOL	VALUE	UNIT
Supply Voltage Range	V_{CC}	-0.5~7	V
DC Input Voltage	V_{IN}	-0.5~ $V_{CC}+0.5$	V
DC Output Voltage	V_{OUT}	-0.5~ $V_{CC}+0.5$	V
Input Diode Current	I_{IK}	± 20	mA
Output Diode Current	I_{OK}	± 20	mA
DC Output Current	I_{OUT}	± 25	mA
DC V_{CC} / Ground Current	I_{CC}	± 50	mA
Power Dissipation	P_D	500 (DIP)* / 180 (SOP)	mW
Storage Temperature	T_{stg}	-65~150	°C

*500mW in the range of $T_a = -40^\circ\text{C} \sim 65^\circ\text{C}$. From $T_a = 65^\circ\text{C}$ to 85°C a derating factor of $-10\text{mW}/^\circ\text{C}$ shall be applied until 300mW.

RECOMMENDED OPERATING CONDITIONS

PARAMETER	SYMBOL	VALUE	UNIT
Supply Voltage	V_{CC}	2~6	V
Input Voltage	V_{IN}	0~ V_{CC}	V
Output Voltage	V_{OUT}	0~ V_{CC}	V
Operating Temperature	T_{opr}	-40~85	°C
Input Rise and Fall Time	t_r, t_f	0~1000 ($V_{CC} = 2.0\text{V}$) 0~500 ($V_{CC} = 4.5\text{V}$) 0~400 ($V_{CC} = 6.0\text{V}$)	ns

DC ELECTRICAL CHARACTERISTICS

PARAMETER	SYMBOL	TEST CONDITION	V_{CC} (V)	$T_a = 25^\circ\text{C}$			$T_a = -40 \sim 85^\circ\text{C}$		UNIT				
				MIN.	TYP.	MAX.	MIN.	MAX.					
High - Level Input Voltage	V_{IH}		2.0	1.50	—	—	1.50	—	V				
			4.5	3.15	—	—	3.15	—					
			6.0	4.20	—	—	4.20	—					
Low - Level Input Voltage	V_{IL}		2.0	—	—	0.50	—	0.50	V				
			4.5	—	—	1.35	—	1.35					
			6.0	—	—	1.80	—	1.80					
High - Level Output Voltage	V_{OH}	$V_{IN} = V_{IH}$ or V_{IL}	$I_{OH} = -20\mu\text{A}$	2.0	1.9	2.0	—	1.9	—	V			
				4.5	4.4	4.5	—	4.4	—				
				6.0	5.9	6.0	—	5.9	—				
Low - Level Output Voltage	V_{OL}	$V_{IN} = V_{IH}$ or V_{IL}	$I_{OL} = 20\mu\text{A}$	2.0	—	0.0	0.1	—	0.1	V			
				4.5	—	0.0	0.1	—	0.1				
				6.0	—	0.0	0.1	—	0.1				
3 - State Output Off - State Current	I_{OZ}^*	$V_{IN} = V_{IH}$ or V_{IL} $V_{OUT} = V_{CC}$ or GND	6.0	—	—	± 0.5	—	± 5.0	μA				
				Input Leakage Current	I_{IN}	$V_{IN} = V_{CC}$ or GND	6.0	—		—	± 0.1	—	± 1.0
				Quiescent Supply Current	I_{CC}	$V_{IN} = V_{CC}$ or GND	6.0	—		—	4.0	—	40.0

* TC74HC253A only

AC ELECTRICAL CHARACTERISTICS ($C_L = 15\text{pF}$, $V_{CC} = 5\text{V}$, $T_a = 25^\circ\text{C}$, Input $t_r = t_f = 6\text{ns}$)

PARAMETER	SYMBOL	TEST CONDITION	MIN.	TYP.	MAX.	UNIT
Output Transition Time	t_{TLH} t_{THL}		—	4	8	ns
Propagation Delay Time ($C_n - Y$)	t_{pLH} t_{pHL}		—	12	19	
Propagation Delay Time ($A, B - Y$)	t_{pLH} t_{pHL}		—	17	26	
Propagation Delay Time ($\bar{G} - Y$) *	t_{pLH} t_{pHL}		—	8	16	
3-State Output Enable Time ($\bar{G} - Y$) **	t_{pZL} t_{pZH}	$R_L = 1\text{k}\Omega$	—	9	16	

AC ELECTRICAL CHARACTERISTICS ($C_L = 50\text{pF}$, Input $t_r = t_f = 6\text{ns}$)

PARAMETER	SYMBOL	TEST CONDITION	V_{CC} (V)	$T_a = 25^\circ\text{C}$			$T_a = -40 \sim 85^\circ\text{C}$		UNIT
				MIN.	TYP.	MAX.	MIN.	MAX.	
Output Transition Time	t_{TLH} t_{THL}		2.0	—	30	75	—	95	ns
			4.5	—	8	15	—	19	
			6.0	—	7	13	—	16	
Propagation Delay Time ($C_n - Y$)	t_{pLH} t_{pHL}		2.0	—	48	115	—	145	
			4.5	—	15	23	—	29	
			6.0	—	12	20	—	25	
Propagation Delay Time ($A, B - Y$)	t_{pLH} t_{pHL}		2.0	—	68	150	—	190	
			4.5	—	20	30	—	38	
			6.0	—	16	26	—	33	
Propagation Delay Time ($\bar{G} - Y$) *	t_{pLH} t_{pHL}		2.0	—	31	95	—	120	
			4.5	—	11	19	—	24	
			6.0	—	9	16	—	20	
3-State Output Enable Time ($\bar{G} - Y$) **	t_{pZL} t_{pZH}	$R_L = 1\text{k}\Omega$	2.0	—	36	100	—	125	
			4.5	—	12	20	—	25	
			6.0	—	9	17	—	21	
3-State Output Disable Time ($\bar{G} - Y$) **	t_{pLZ} t_{pHZ}	$R_L = 1\text{k}\Omega$	2.0	—	22	115	—	145	
			4.5	—	13	23	—	29	
			6.0	—	11	20	—	25	
Input Capacitance	C_{IN}			—	5	10	—	10	pF
Power Dissipation Capacitance	C_{PD} (1)	TC74HC153A		—	58	—	—	—	
		TC74HC253A		—	59	—	—	—	

Note (1) C_{PD} is defined as the value of the internal equivalent capacitance which is calculated from the operating current consumption without load.

Average operating current can be obtained by the equation :

$$I_{CC}(\text{opr}) = C_{PD} \cdot V_{CC} \cdot f_{IN} + I_{CC}$$

*: for TC74HC153A only

** : for TC74HC253A only

DIP 16PIN OUTLINE DRAWING (DIP16-P-300-2.54A)

Unit in mm

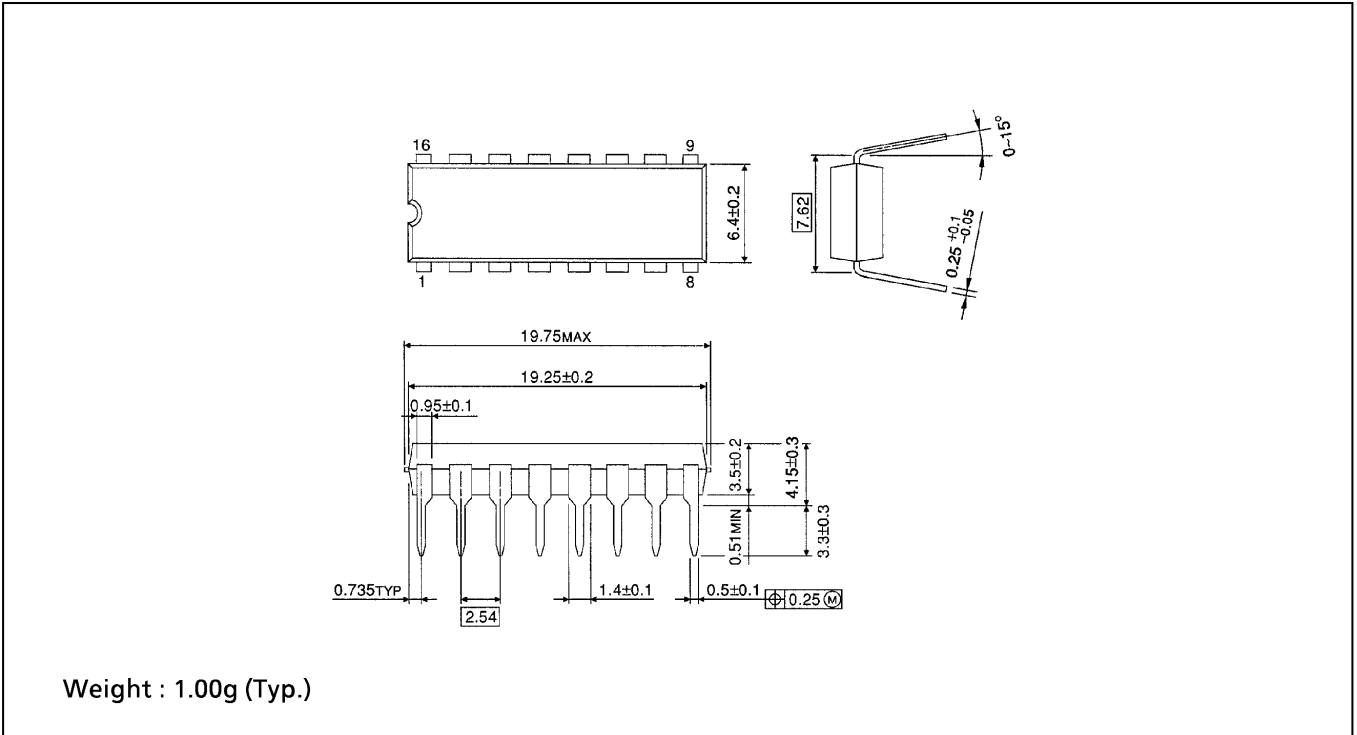

SOP 16PIN (200mil BODY) OUTLINE DRAWING (SOP16-P-300-1.27)

Unit in mm

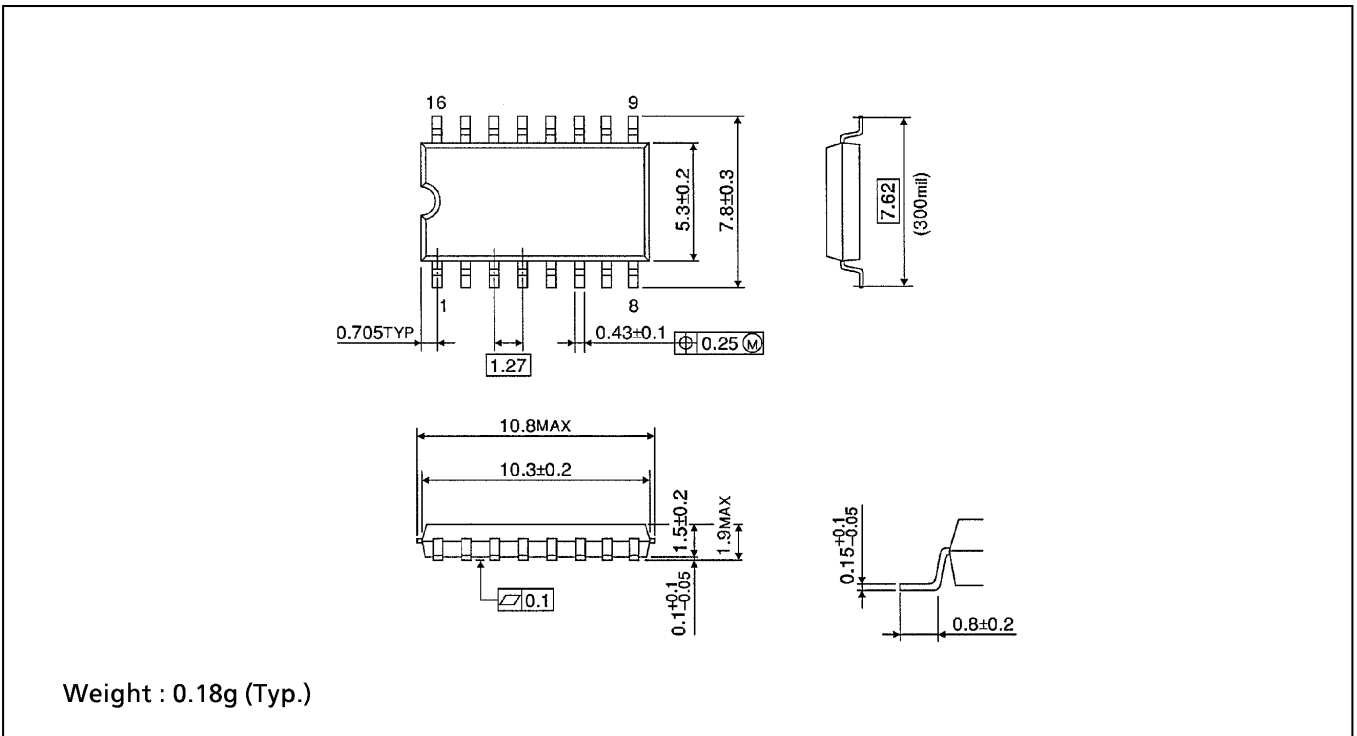

SOP 16PIN (150mil BODY) OUTLINE DRAWING (SOL16-P-150-1.27)

Unit in mm

(Note) This package is not available in Japan.

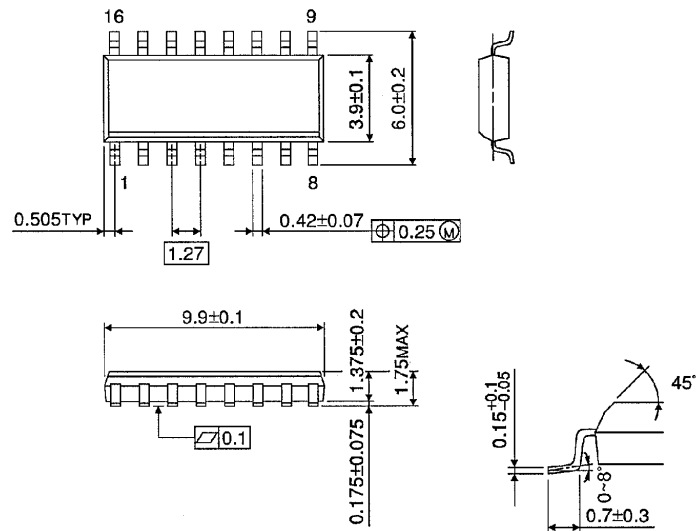

Weight : 0.13g (Typ.)