

TOSHIBA CMOS DIGITAL INTEGRATED CIRCUIT SILICON MONOLITHIC

TC74HC165AP, TC74HC165AF, TC74HC165AFN

8 - BIT SHIFT REGISTER (P - IN, S - OUT)

(Note) The JEDEC SOP (FN) is not available in Japan.

The TC74HC165A is a high speed CMOS 8-BIT PARALLEL/SERIAL-IN, SERIAL-OUT SHIFT REGISTER fabricated with silicon gate C²MOS technology. It achieves the high speed operation similar to equivalent LSTTL while maintaining the CMOS low power dissipation. It consists of parallel-in or serial-in, serial-out 8 - bit shift register with a gated clock inputs. When the SHIFT/LOAD input is held high, the serial data input is enabled and the eight flip-flops perform serial shifting with each clock pulse. When the SHIFT/LOAD input is held low, the parallel data is loaded asynchronously into the register at positive going transition of the clock pulse. The CK-INH input should be shifted high only when the CK input is held high. All inputs are equipped with protection circuits against static discharge or transient excess voltage.

FEATURES :

- High Speed..... $f_{MAX} = 56\text{MHz}(\text{typ.})$ at $V_{CC} = 5\text{V}$
- Low Power Dissipation..... $I_{CC} = 4\mu\text{A}(\text{Max.})$ at $T_a = 25^\circ\text{C}$
- High Noise Immunity..... $V_{NIH} = V_{NIL} = 28\% V_{CC} (\text{Min.})$
- Output Drive Capability..... 10 LSTTL Loads
- Symmetrical Output Impedance... $|I_{OH}| = |I_{OL}| = 4\text{mA}(\text{Min.})$
- Balanced Propagation Delays..... $t_{pLH} \approx t_{pHL}$
- Wide Operating Voltage Range... $V_{CC} (\text{opr.}) = 2\text{V} \sim 6\text{V}$
- Pin and Function Compatible with 74LS165

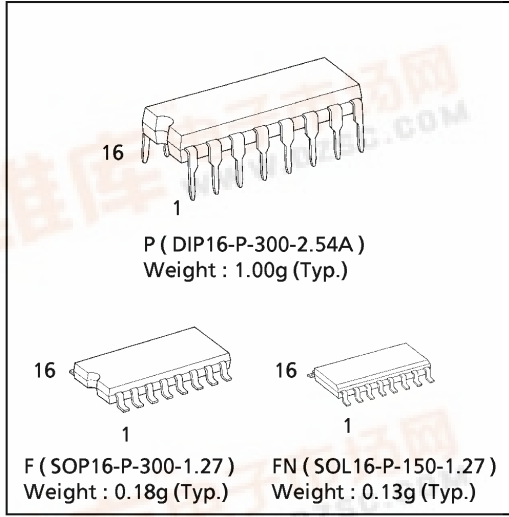

PIN ASSIGNMENT

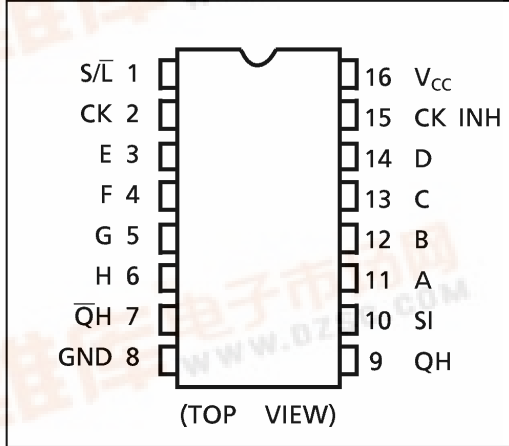

IEC LOGIC SYMBOL

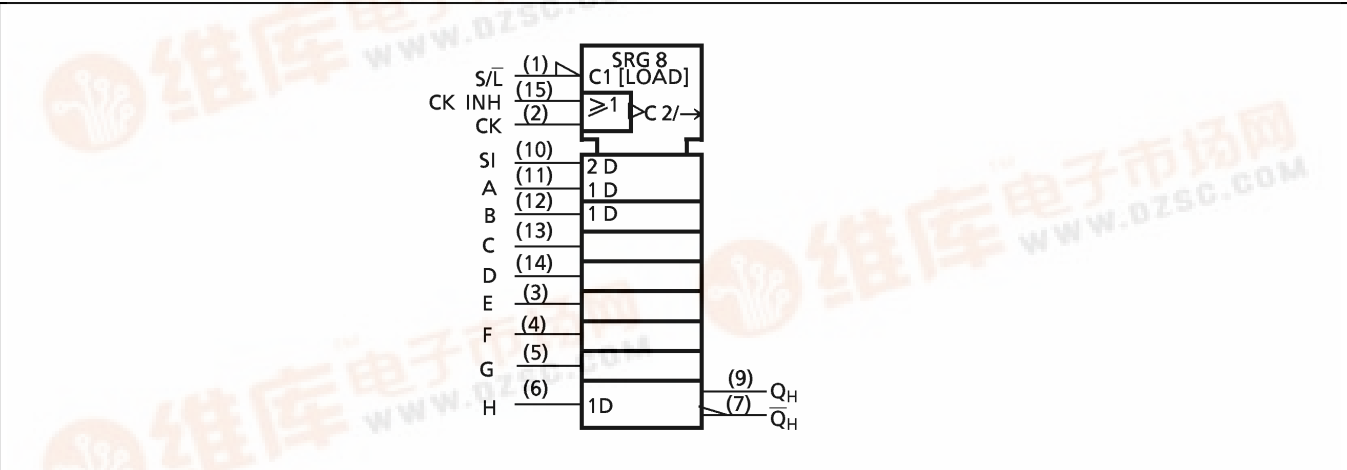

980508EBA2

● TOSHIBA is continually working to improve the quality and the reliability of its products. Nevertheless, semiconductor devices in general can malfunction or fail due to their inherent electrical sensitivity and vulnerability to physical stress. It is the responsibility of the buyer, when utilizing TOSHIBA products, to observe standards of safety, and to avoid situations in which a malfunction or failure of a TOSHIBA product could cause loss of human life, bodily injury or damage to property. In developing your designs, please ensure that TOSHIBA products are used within specified operating ranges as set forth in the most recent products specifications. Also, please keep in mind the precautions and conditions set forth in the TOSHIBA Semiconductor Reliability Handbook.



TRUTH TABLE

INPUTS					INTERNAL OUTPUTS		OUTPUT	
SHIFT/LOAD	CLOCK INH	CLOCK	SERIAL IN	PARALLEL A H	QA	QB	QH	\overline{QH}
L	X	X	X	a h	a	b	h	\overline{h}
H	L	\uparrow	H	X	H	QAn	QGn	\overline{QGn}
H	L	\uparrow	L	X	L	QAn	QGn	\overline{QGn}
H	\uparrow	L	H	X	H	QAn	QGn	\overline{QGn}
H	\uparrow	L	L	X	L	QAn	QGn	\overline{QGn}
H	X	H	X	X	NO CHANGE			
H	H	X	X	X	NO CHANGE			

X : Don't Care
 a h : The level of steady state input voltage at inputs A through H respectively
 QAn~QGn : The level of QA~QG, respectively, before the most recent positive transition of the CK.

TIMING CHART

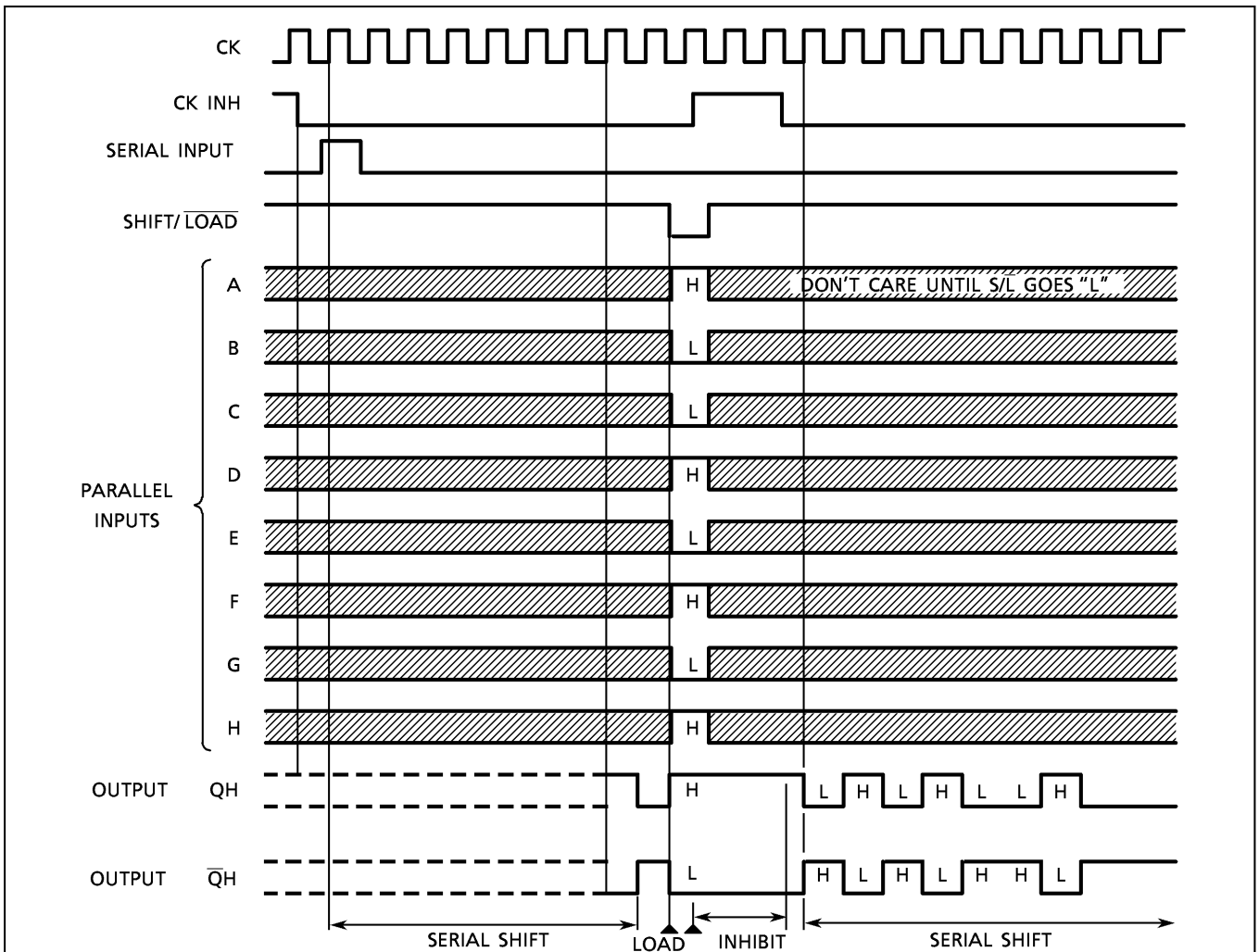

980508EBA2'

- The products described in this document are subject to foreign exchange and foreign trade laws.
- The information contained herein is presented only as a guide for the applications of our products. No responsibility is assumed by TOSHIBA CORPORATION for any infringements of intellectual property or other rights of the third parties which may result from its use. No license is granted by implication or otherwise under any intellectual property or other rights of TOSHIBA CORPORATION or others.
- The information contained herein is subject to change without notice.

SYSTEM DIAGRAM

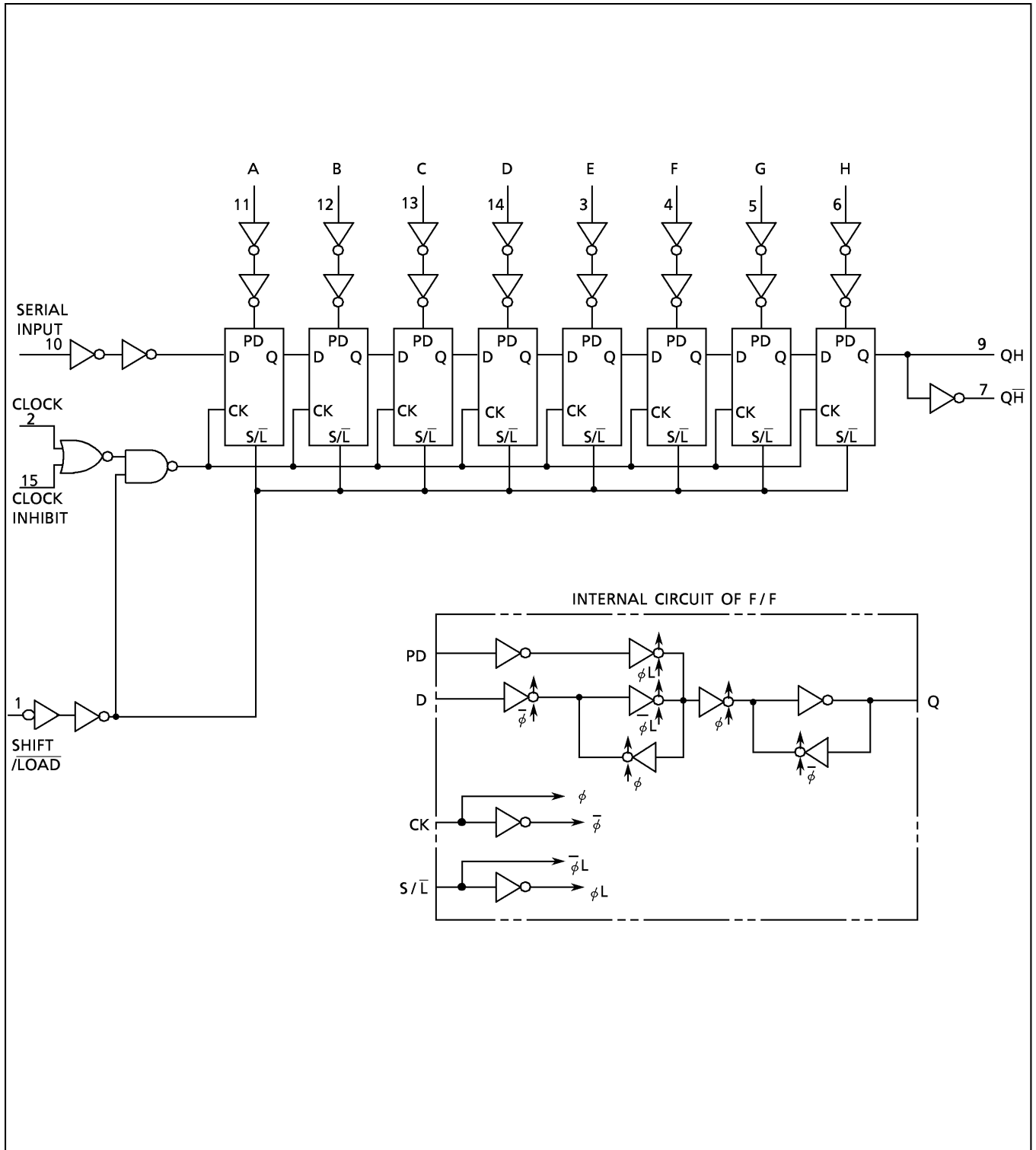

ABSOLUTE MAXIMUM RATINGS

PARAMETER	SYMBOL	VALUE	UNIT
Supply Voltage Range	V_{CC}	-0.5~7	V
DC Input Voltage	V_{IN}	-0.5~ $V_{CC} + 0.5$	V
DC Output Voltage	V_{OUT}	-0.5~ $V_{CC} + 0.5$	V
Input Diode Current	I_{IK}	± 20	mA
Output Diode Current	I_{OK}	± 20	mA
DC Output Current	I_{OUT}	± 25	mA
DC V_{CC} / Ground Current	I_{CC}	± 50	mA
Power Dissipation	P_D	500 (DIP)* / 180 (SOP)	mW
Storage Temperature	T_{stg}	-65~150	°C

*500mW in the range of $T_a = -40^{\circ}\text{C} \sim 65^{\circ}\text{C}$. From $T_a = 65^{\circ}\text{C}$ to 85°C a derating factor of $-10\text{mW}/^{\circ}\text{C}$ shall be applied until 300mW.

RECOMMENDED OPERATING CONDITIONS

PARAMETER	SYMBOL	VALUE	UNIT
Supply Voltage	V_{CC}	2~6	V
Input Voltage	V_{IN}	0~ V_{CC}	V
Output Voltage	V_{OUT}	0~ V_{CC}	V
Operating Temperature	T_{opr}	-40~85	°C
Input Rise and Fall Time	t_r, t_f	0~ 1000 ($V_{CC} = 2.0\text{V}$) 0~ 500 ($V_{CC} = 4.5\text{V}$) 0~ 400 ($V_{CC} = 6.0\text{V}$)	ns

DC ELECTRICAL CHARACTERISTICS

PARAMETER	SYMBOL	TEST CONDITION	V_{CC} (V)	$T_a = 25^{\circ}\text{C}$			$T_a = -40 \sim 85^{\circ}\text{C}$		UNIT	
				MIN.	TYP.	MAX.	MIN.	MAX.		
High - Level Input Voltage	V_{IH}		2.0	1.50	—	—	1.50	—	V	
			4.5	3.15	—	—	3.15	—		
			6.0	4.20	—	—	4.20	—		
Low - Level Input Voltage	V_{IL}		2.0	—	—	0.50	—	0.50	V	
			4.5	—	—	1.35	—	1.35		
			6.0	—	—	1.80	—	1.80		
High - Level Output Voltage	V_{OH}	$V_{IN} = V_{IH}$ or V_{IL}	$I_{OH} = -20\mu\text{A}$	2.0	1.9	2.0	—	1.9	—	V
				4.5	4.4	4.5	—	4.4	—	
			$I_{OH} = -4\text{ mA}$ $I_{OH} = -5.2\text{ mA}$	4.5	4.18	4.31	—	4.13	—	
				6.0	5.68	5.80	—	5.63	—	
Low - Level Output Voltage	V_{OL}	$V_{IN} = V_{IH}$ or V_{IL}	$I_{OL} = 20\mu\text{A}$	2.0	—	0.0	0.1	—	0.1	V
				4.5	—	0.0	0.1	—	0.1	
			$I_{OL} = 4\text{ mA}$ $I_{OL} = 5.2\text{ mA}$	4.5	—	0.17	0.26	—	0.33	
				6.0	—	0.18	0.26	—	0.33	
Input Leakage Current	I_{IN}	$V_{IN} = V_{CC}$ or GND	6.0	—	—	± 0.1	—	± 1.0	μA	
Quiescent Supply Current	I_{CC}	$V_{IN} = V_{CC}$ or GND	6.0	—	—	4.0	—	40.0		

TIMING REQUIREMENTS OPERATING CONDITIONS (Input $t_r = t_f = 6ns$)

PARAMETER	SYMBOL	TEST CONDITION	$V_{CC}(V)$	Ta = 25°C		Ta = -40~85°C	UNIT
				TYP.	LIMIT	LIMIT	
Minimum Pulse Width (CK, CK INH)	$t_{W(H)}$ $t_{W(L)}$		2.0	—	75	95	ns
			4.5	—	15	19	
			6.0	—	13	16	
Minimum Pulse Width (S/ \bar{L})	$t_{W(L)}$		2.0	—	75	95	
			4.5	—	15	19	
			6.0	—	13	16	
Minimum Set-up Time (PI-S/ \bar{L})	t_s		2.0	—	75	95	
			4.5	—	15	19	
			6.0	—	13	16	
Minimum Set-up Time (SI-CK, CK INH)	t_s		2.0	—	75	95	
			4.5	—	15	19	
			6.0	—	13	16	
Minimum Set-up Time (S/ \bar{L} -CK, CK INH)	t_s		2.0	—	75	95	
			4.5	—	15	19	
			6.0	—	13	16	
Minimum Hold Time (PI-S/ \bar{L})	t_h		2.0	—	0	0	
			4.5	—	0	0	
			6.0	—	0	0	
Minimum Hold Time (SI-CK, CK INH)	t_h		2.0	—	0	0	
			4.5	—	0	0	
			6.0	—	0	0	
Minimum Hold Time (S/ \bar{L} -CK, CK INH)	t_h		2.0	—	0	0	
			4.5	—	0	0	
			6.0	—	0	0	
Minimum Removal Time (CK INH-CK) (CK-CK INH)	t_{rem}		2.0	—	75	95	
			4.5	—	15	19	
			6.0	—	13	16	
Clock Frequency	f		2.0	—	7	6	MHz
			4.5	—	30	24	
			6.0	—	41	28	

AC ELECTRICAL CHARACTERISTICS ($C_L = 15pF$, $V_{CC} = 5V$, Ta = 25°C, Input $t_r = t_f = 6ns$)

PARAMETER	SYMBOL	TEST CONDITION	MIN.	TYP.	MAX.	UNIT
Output Transition Time	t_{TLH}		—	4	8	ns
	t_{THL}					
Propagation Delay Time (CK, CK INH-QH, $\bar{Q}H$)	t_{pLH}		—	15	25	
	t_{pHL}					
Propagation Delay Time (S/ \bar{L} -QH, $\bar{Q}H$)	t_{pLH}		—	15	25	
	t_{pHL}					
Propagation Delay Time (H-QH, $\bar{Q}H$)	t_{pLH} t_{pHL}		—	14	26	
Maximum Clock Frequency	f_{MAX}		35	56	—	MHz

AC ELECTRICAL CHARACTERISTICS ($C_L = 50\text{pF}$, Input $t_r = t_f = 6\text{ns}$)

PARAMETER	SYMBOL	TEST CONDITION	V_{CC} (V)	$T_a = 25^\circ\text{C}$			$T_a = -40\sim 85^\circ\text{C}$		UNIT
				MIN.	TYP.	MAX.	MIN.	MAX.	
Output Transition Time	t_{TLH} t_{THL}		2.0	—	25	75	—	95	ns
			4.5	—	8	15	—	19	
			6.0	—	7	13	—	16	
Propagation Delay Time (CK, CK INH—QH, $\overline{\text{QH}}$)	t_{pLH} t_{pHL}		2.0	—	55	150	—	190	
			4.5	—	18	30	—	38	
			6.0	—	15	26	—	33	
Propagation Delay Time (S/L—QH, $\overline{\text{QH}}$)	t_{pLH} t_{pHL}		2.0	—	60	165	—	205	
			4.5	—	19	33	—	41	
			6.0	—	16	28	—	35	
Propagation Delay Time (H—QH, $\overline{\text{QH}}$)	t_{pHL}		2.0	—	52	135	—	170	
			4.5	—	17	27	—	34	
			6.0	—	14	23	—	29	
Maximum Clock Frequency Frequency	f_{MAX}		2.0	7	14	—	6	—	MHz
			4.5	30	46	—	24	—	
			6.0	41	65	—	28	—	
Input Capacitance	C_{IN}			—	5	10	—	10	pF
Power Dissipation Capacitance	C_{PD} (1)			—	55	—	—	—	

Note (1) C_{PD} is defined as the value of the internal equivalent capacitance which is calculated from the operating current consumption without load.

Average operating current can be obtained by the equation :

$$I_{CC}(\text{opr}) = C_{PD} \cdot V_{CC} \cdot f_{IN} + I_{CC}$$

DIP 16PIN OUTLINE DRAWING (DIP16-P-300-2.54A)

Unit in mm

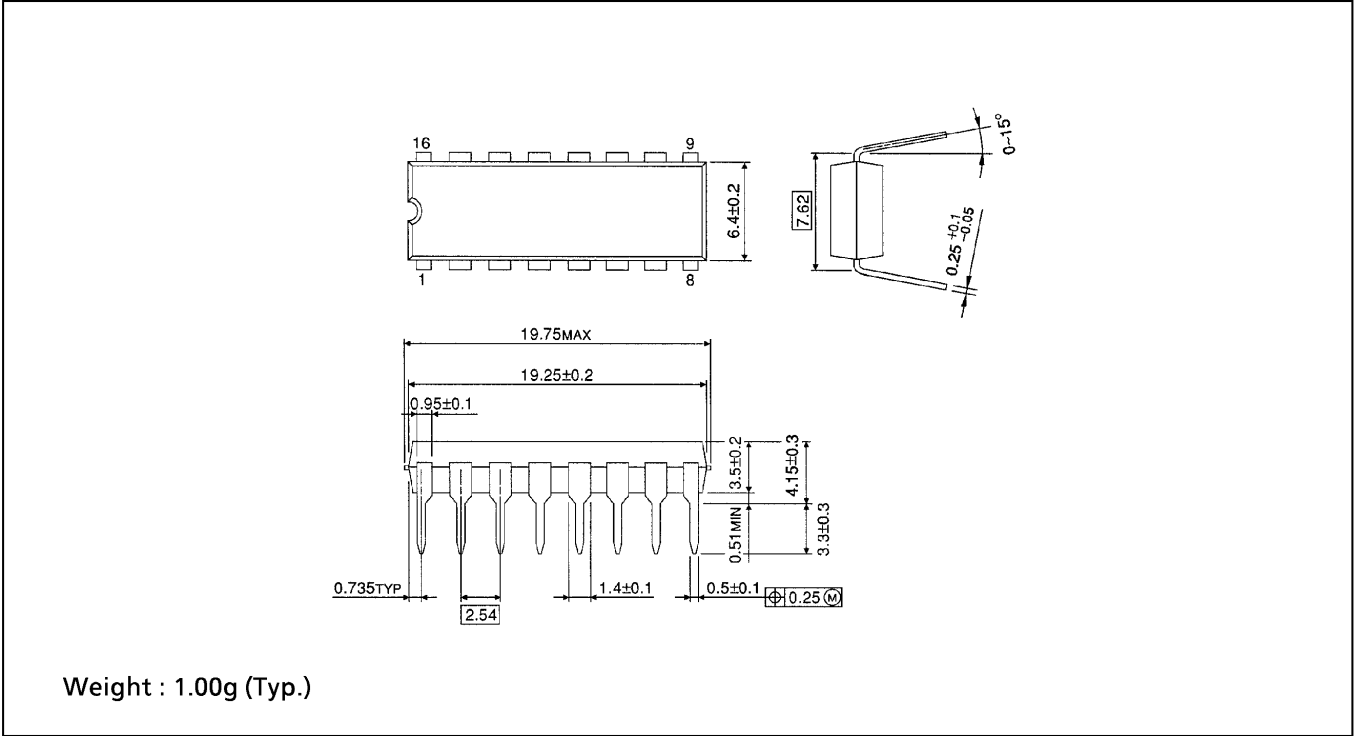

SOP 16PIN (200mil BODY) OUTLINE DRAWING (SOP16-P-300-1.27)

Unit in mm

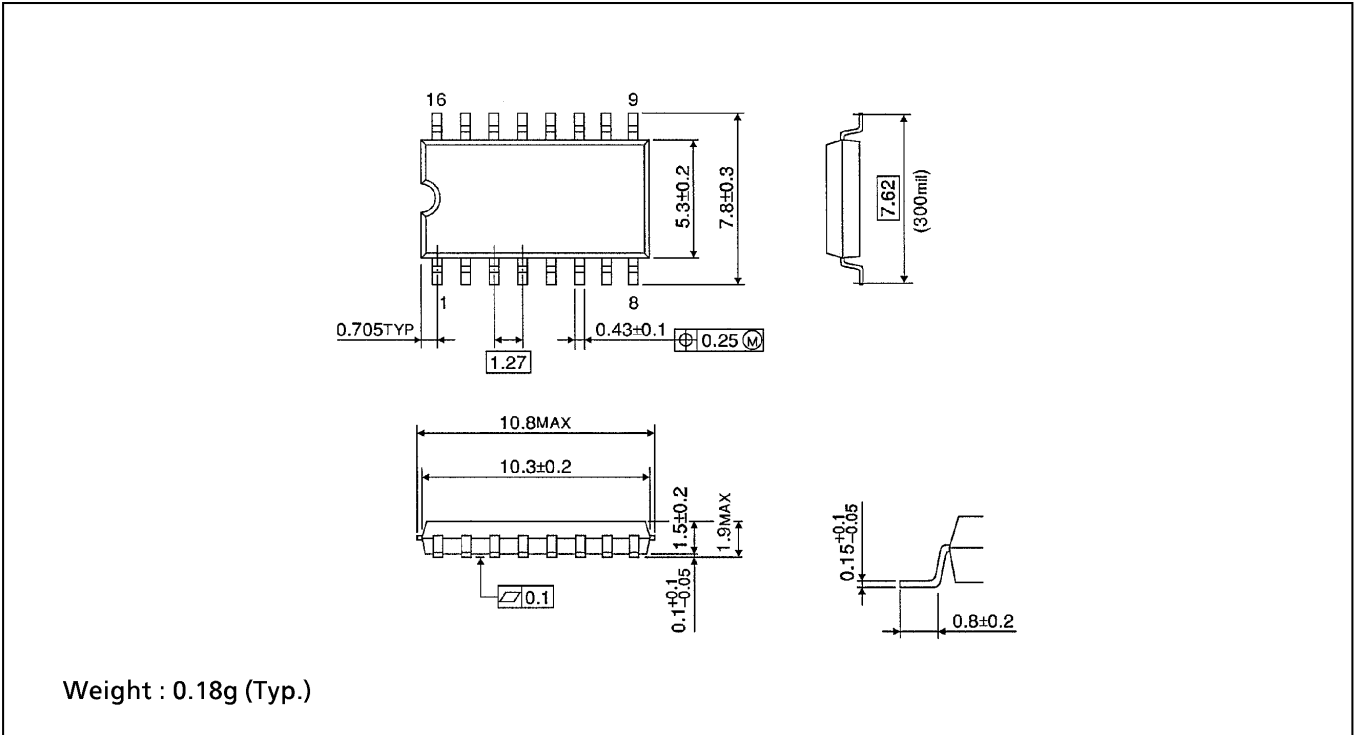

SOP 16PIN (150mil BODY) OUTLINE DRAWING (SOL16-P-150 -1.27)

Unit in mm

(Note) This package is not available in Japan.

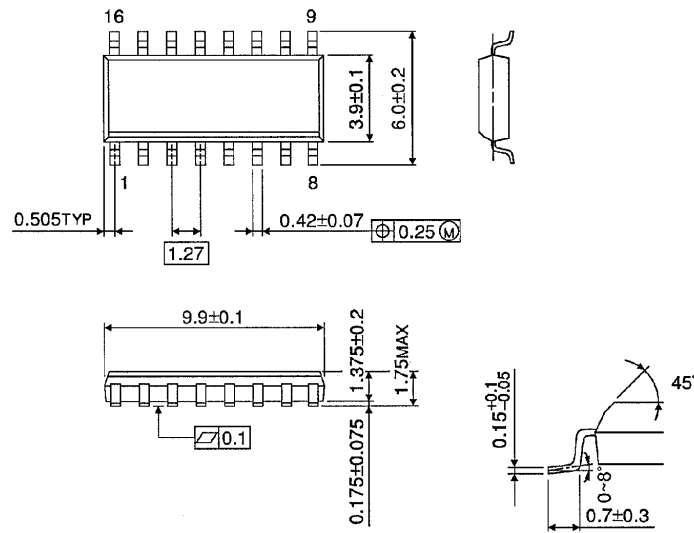

Weight : 0.13g (Typ.)