



DS1742 Y2KC Nonvolatile Timekeeping RAM

www.dalsemi.com

FEATURES

- Integrated NV SRAM, real time clock, crystal, power-fail control circuit and lithium energy source
- Clock registers are accessed identical to the static RAM. These registers are resident in the eight top RAM locations
- Century byte register
- Totally nonvolatile with over 10 years of operation in the absence of power
- BCD coded century, year, month, date, day, hours, minutes, and seconds with automatic leap year compensation valid up to the year 2100
- Battery voltage level indicator flag
- Power-fail write protection allows for $\pm 10\%$ V_{CC} power supply tolerance
- Lithium energy source is electrically disconnected to retain freshness until power is applied for the first time
- Standard JEDEC bytewise 2k x 8 static RAM pinout
- Quartz accuracy ± 1 minute a month @ 25°C, factory calibrated

PIN ASSIGNMENT

A7	1	24	V_{CC}
A6	2	23	A8
A5	3	22	A9
A4	4	21	WE
A3	5	20	OE
A2	6	19	A10
A1	7	18	CE
A0	8	17	DQ7
DQ0	9	16	DQ6
DQ1	10	15	DQ5
DQ2	11	14	DQ4
GND	12	13	DQ3

PIN DESCRIPTION

A0-A10	- Address Inputs
\overline{CE}	- Chip Enable
\overline{OE}	- Output Enable
\overline{WE}	- Write Enable
V_{CC}	- Power Supply Input
GND	- Ground
DQ0-DQ7	- Data Input/Outputs

ORDERING INFORMATION

DS1742-XXX (5 Volt)

→ -70	70 ns access
→ -100	100 ns access

DS1742W-XXX (3.3 Volt)

→ -120	120 ns access
→ -150	150 ns access

DESCRIPTION

The DS1742 is a full function, year 2000-compliant (Y2KC), real-time clock/calendar (RTC) and 2k x 8 non-volatile static RAM. User access to all registers within the DS1742 is accomplished with a bytewise interface as shown in Figure 1. The Real Time Clock (RTC) information and control bits reside in the eight uppermost RAM locations. The RTC registers contain century, year, month, date, day, hours, minutes, and seconds data in 24-hour BCD format. Corrections for the day of the month and leap year are made automatically.

The RTC clock registers are double-buffered to avoid access of incorrect data that can occur during clock update cycles. The double buffered system also prevents time loss as the timekeeping countdown continues unabated by access to time register data. The DS1742 also contains its own power-fail circuitry which deselected the device when the V_{CC} supply is in an out of tolerance condition. This feature prevents loss of data from unpredictable system operation brought on by low V_{CC} as errant access and update cycles are avoided.

CLOCK OPERATIONS-READING THE CLOCK

While the double-buffered register structure reduces the chance of reading incorrect data, internal updates to the DS1742 clock registers should be halted before clock data is read to prevent reading of data in transition. However, halting the internal clock register updating process does not affect clock accuracy. Updating is halted when a 1 is written into the read bit, bit 6 of the century register, see Table 2. As long as a 1 remains in that position, updating is halted. After a halt is issued, the registers reflect the count, that is day, date, and time that was current at the moment the halt command was issued. However, the internal clock registers of the double-buffered system continue to update so that the clock accuracy is not affected by the access of data. All of the DS1742 registers are updated simultaneously after the internal clock register updating process has been re-enabled. Updating is within a second after the read bit is written to 0.

DS1742 BLOCK DIAGRAM Figure 1

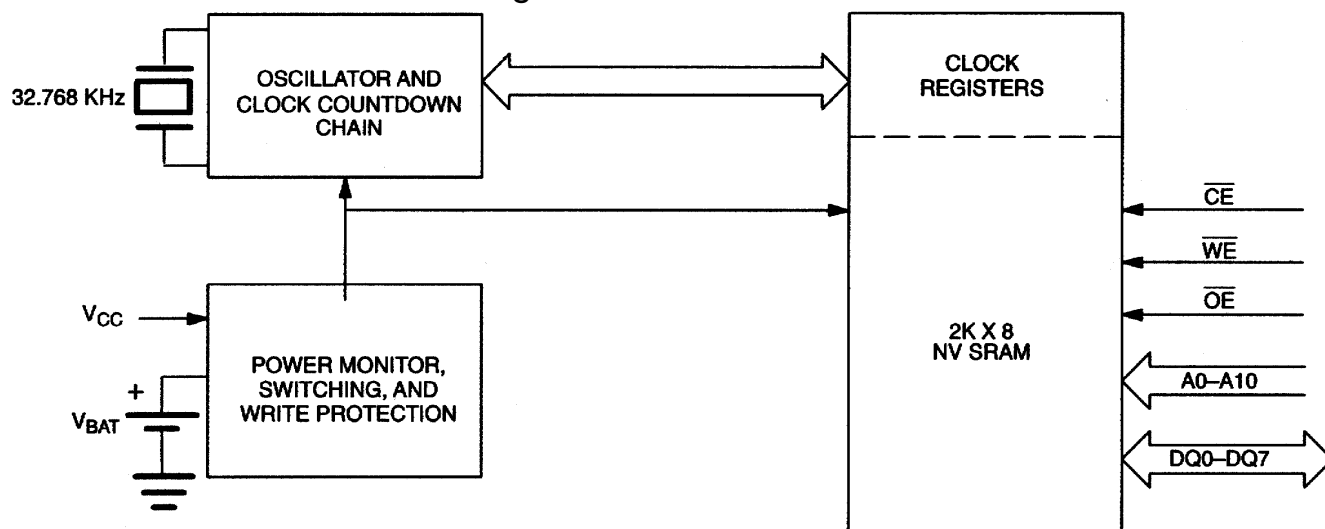

DS1742 TRUTH TABLE Table 1

V_{CC}	\overline{CE}	\overline{OE}	\overline{WE}	MODE	DQ	POWER
In Tolerance	V_{IH}	X	X	DESELECT	HIGH-Z	STANDBY
	V_{IL}	X	V_{IL}	WRITE	DATA IN	ACTIVE
	V_{IL}	V_{IL}	V_{IH}	READ	DATA OUT	ACTIVE
	V_{IL}	V_{IH}	V_{IH}	READ	HIGH-Z	ACTIVE
$<V_{BAT}$	X	X	X	DESELECT	HIGH-Z	CMOS STANDBY
$<V_{BAT}$	X	X	X	DESELECT	HIGH-Z	DATA RETENTION MODE

SETTING THE CLOCK

As shown in Table 2, bit 7 of the century register is the write bit. Setting the write bit to a 1, like the read bit, halts updates to the DS1742 registers. The user can then load them with the correct day, date and

time data in 24-hour BCD format. Resetting the write bit to a 0 then transfers those values to the actual clock counters and allows normal operation to resume.

STOPPING AND STARTING THE CLOCK OSCILLATOR

The clock oscillator may be stopped at any time. To increase the shelf life, the oscillator can be turned off to minimize current drain from the battery. The $\overline{\text{OSC}}$ bit is the MSB (bit 7) of the seconds registers, see Table 2. Setting it to a 1 stops the oscillator.

FREQUENCY TEST BIT

As shown in Table 2, bit 6 of the day byte is the frequency test bit. When the frequency test bit is set to logic 1 and the oscillator is running, the LSB of the seconds register will toggle at 512 Hz. When the seconds register is being read, the $\overline{\text{DQ0}}$ line will toggle at the 512 Hz frequency as long as conditions for access remain valid (i.e., $\overline{\text{CE}}$ low, $\overline{\text{OE}}$ low, $\overline{\text{WE}}$ high, and address for seconds register remain valid and stable).

CLOCK ACCURACY

The DS1742 is guaranteed to keep time accuracy to within ± 1 minute per month at 25°C. The clock is calibrated at the factory by Dallas Semiconductor using special calibration nonvolatile tuning elements. The DS1742 does not require additional calibration and temperature deviations will have a negligible effect in most applications. For this reason, methods of field clock calibration are not available and not necessary.

DS1742 REGISTER MAP Table 2

ADDRESS	DATA								FUNCTION/RANGE
	B ₇	B ₆	B ₅	B ₄	B ₃	B ₂	B ₁	B ₀	
7FF	10 Year				YEAR				YEAR 00-99
7FE	X	X	X	10 Mo	MONTH				MONTH 01-12
7FD	X	X	10 Date		DATE				DATE 01-31
7FC	BF	FT	X	X	X	DAY			DAY 01-07
7FB	X	X	10 HOUR		HOUR				HOUR 00-23
7FA	X	10 MINUTES			MINUTES				MINUTES 00-59
7F9	$\overline{\text{OSC}}$	10 SECONDS			SECONDS				SECONDS 00-59
7F8	W	R	10 CENTURY		CENTURY				CONTROL 00-39

$\overline{\text{OSC}}$ = STOP BIT
W = WRITE BIT

R = READ BIT
X = SEE NOTE BELOW

FT = FREQUENCY TEST
BF = BATTERY FLAG

NOTE:

All indicated “X” bits are not dedicated to any particular function and can be used as normal RAM bits.

RETRIEVING DATA FROM RAM OR CLOCK

The DS1742 is in the read mode whenever $\overline{\text{OE}}$ (output enable) is low, $\overline{\text{WE}}$ (write enable) is high, and $\overline{\text{CE}}$ (chip enable) is low. The device architecture allows ripplethrough access to any of the address locations in the NV SRAM. Valid data will be available at the DQ pins within t_{AA} after the last address input is stable, providing that the $\overline{\text{CE}}$, and $\overline{\text{OE}}$ access times and states are satisfied. If $\overline{\text{CE}}$, or $\overline{\text{OE}}$ access times and states are not met, valid data will be available at the latter of chip enable access (t_{CEA}) or at output enable access time (t_{OEA}). The state of the data input/output pins (DQ) is controlled by $\overline{\text{CE}}$, and $\overline{\text{OE}}$. If the outputs are activated before t_{AA} , the data lines are driven to an intermediate state until t_{AA} . If the

address inputs are changed while \overline{CE} , and \overline{OE} remain valid, output data will remain valid for output data hold time (t_{OH}) but will then go indeterminate until the next address access.

WRITING DATA TO RAM OR CLOCK

The DS1742 is in the write mode whenever \overline{WE} , and \overline{CE} are in their active state. The start of a write is referenced to the latter occurring transition of \overline{WE} , on \overline{CE} . The addresses must be held valid throughout the cycle. \overline{CE} , or \overline{WE} must return inactive for a minimum of t_{WR} prior to the initiation of another read or write cycle. Data in must be valid t_{DS} prior to the end of write and remain valid for t_{DH} afterward. In a typical application, the \overline{OE} signal will be high during a write cycle. However, \overline{OE} can be active provided that care is taken with the data bus to avoid bus contention. If \overline{OE} is low prior to \overline{WE} transitioning low the data bus can become active with read data defined by the address inputs. A low transition on \overline{WE} will then disable the outputs t_{WEZ} after \overline{WE} goes active.

DATA RETENTION MODE

The 5-volt device is fully accessible and data can be written or read only when V_{CC} is greater than V_{PF} . However, when V_{CC} is below the power-fail point, V_{PF} , (point at which write protection occurs) the internal clock registers and SRAM are blocked from any access. When V_{CC} falls below the battery switch point V_{SO} (battery supply level), device power is switched from the V_{CC} pin to the backup battery. RTC operation and SRAM data are maintained from the battery until V_{CC} is returned to nominal levels.

The 3.3-volt device is fully accessible and data can be written or read only when V_{CC} is greater than V_{PF} . When V_{CC} falls below the power-fail point, V_{PF} , access to the device is inhibited. If V_{PF} is less than V_{BAT} , the device power is switched from V_{CC} to the backup supply (V_{BAT}) when V_{CC} drops below V_{PF} . If V_{PF} is greater than V_{BAT} , the device power is switched from V_{CC} to the backup supply (V_{BAT}) when V_{CC} drops below V_{BAT} . RTC operation and SRAM data are maintained from the battery until V_{CC} is returned to nominal levels.

BATTERY LONGEVITY

The DS1742 has a lithium power source that is designed to provide energy for clock activity, and clock and RAM data retention when the V_{CC} supply is not present. The capability of this internal power supply is sufficient to power the DS1742 continuously for the life of the equipment in which it is installed. For specification purposes, the life expectancy is 10 years at 25°C with the internal clock oscillator running in the absence of V_{CC} power. Each DS1742 is shipped from Dallas Semiconductor with its lithium energy source disconnected, guaranteeing full energy capacity. When V_{CC} is first applied at a level greater than V_{PF} , the lithium energy source is enabled for battery backup operation. Actual life expectancy of the DS1742 will be much longer than 10 years since no lithium battery energy is consumed when V_{CC} is present.

BATTERY MONITOR

The DS1742 constantly monitors the battery voltage of the internal battery. The Battery Flag bit (bit 7) of the day register is used to indicate the voltage level range of the battery. This bit is not writable and should always be a 1 when read. If a 0 is ever present, an exhausted lithium energy source is indicated and both the contents of the RTC and RAM are questionable.

ABSOLUTE MAXIMUM RATINGS*

Voltage on Any Pin Relative to Ground	-0.3V to +6.0V
Operating Temperature	0°C to 70°C
Storage Temperature	-20°C to +70°C
Soldering Temperature	260°C for 10 seconds (See Note 7)

* This is a stress rating only and functional operation of the device at these or any other conditions above those indicated in the operation sections of this specification is not implied. Exposure to absolute maximum rating conditions for extended periods of time may affect reliability.

RECOMMENDED DC OPERATING CONDITIONS (0°C to 70°C)

PARAMETER	SYMBOL	MIN	TYP	MAX	UNITS	NOTES
Logic 1 Voltage All Inputs $V_{CC} = 5V \pm 10\%$	V_{IH}	2.2		$V_{CC} + 0.3V$	V	1
$V_{CC} = 3.3V \pm 10\%$	V_{IH}	2.0		$V_{CC} + 0.3V$	V	1
Logic 0 Voltage All Inputs $V_{CC} = 5V \pm 10\%$	V_{IL}	-0.3		0.8	V	1
$V_{CC} = 3.3V \pm 10\%$	V_{IL}	-0.3		0.6	V	1

DC ELECTRICAL CHARACTERISTICS (0°C to 70°C; $V_{CC} = 5.0V \pm 10\%$)

PARAMETER	SYMBOL	MIN	TYP	MAX	UNITS	NOTES
Active Supply Current	I_{CC}		15	50	mA	2, 3
TTL Standby Current ($\overline{CE} = V_{IH}$)	I_{CC1}		1	3	mA	2, 3
CMOS Standby Current ($\overline{CE} \geq V_{CC} - 0.2V$)	I_{CC2}		1	3	mA	2, 3
Input Leakage Current (any input)	I_{IL}	-1		+1	μA	
Output Leakage Current (any output)	I_{OL}	-1		+1	μA	
Output Logic 1 Voltage ($I_{OUT} = -1.0 mA$)	V_{OH}	2.4				1
Output Logic 0 Voltage ($I_{OUT} = +2.1 mA$)	V_{OL}			0.4		1
Write Protection Voltage	V_{PF}	4.25	4.37	4.50	V	1
Battery Switch-over Voltage	V_{SO}		V_{BAT}			1, 4

DC ELECTRICAL CHARACTERISTICS (0°C to 70°C; $V_{CC} = 3.3V \pm 10\%$)

PARAMETER	SYMBOL	MIN	TYP	MAX	UNITS	NOTES
Active Supply Current	I_{CC}		10	30	mA	2, 3
TTL Standby Current ($\overline{CE} = V_{IH}$)	I_{CC1}		0.7	2	mA	2, 3
CMOS Standby Current ($\overline{CE} \geq V_{CC} - 0.2V$)	I_{CC2}		0.7	2	mA	2, 3
Input Leakage Current (any input)	I_{IL}	-1		+1	μA	
Output Leakage Current (any output)	I_{OL}	-1		+1	μA	
Output Logic 1 Voltage ($I_{OUT} = -1.0$ mA)	V_{OH}	2.4				1
Output Logic 0 Voltage ($I_{OUT} = 2.1$ mA)	V_{OL}			0.4		1
Write Protection Voltage	V_{PF}	2.80	2.88	2.97	V	1
Battery Switch-over Voltage	V_{SO}		V_{BAT} OR V_{PF}		V	1, 4

READ CYCLE, AC CHARACTERISTICS (0°C to 70°C; $V_{CC} = 5.0V \pm 10\%$)

PARAMETER	SYMBOL	70 ns access		100 ns access		UNITS	NOTES
		MIN	MAX	MIN	MAX		
Read Cycle Time	t_{RC}	70		100		ns	
Address Access Time	t_{AA}		70		100	ns	
\overline{CE} to DQ Low-Z	t_{CEL}	5		5		ns	
\overline{CE} Access Time	t_{CEA}		70		100	ns	
\overline{CE} Data Off time	t_{CEZ}		25		35	ns	
\overline{OE} to DQ Low-Z	t_{OEL}	5		5		ns	
\overline{OE} Access Time	t_{OEA}		35		55	ns	
\overline{OE} Data Off Time	t_{OEZ}		25		35	ns	
Output Hold from Address	t_{OH}	5		5		ns	

READ CYCLE, AC CHARACTERISTICS(0°C to 70°C; $V_{CC} = 3.3V \pm 10\%$)

PARAMETER	SYMBOL	120 ns access		150 ns access		UNITS	NOTES
		MIN	MAX	MIN	MAX		
Read Cycle Time	t_{RC}	120		150		ns	5
Address Access Time	t_{AA}		120		150	ns	5
\overline{CE} to DQ Low-Z	t_{CEL}	5		5		ns	5
\overline{CE} Access Time	t_{CEA}		120		150	ns	5
\overline{CE} Data Off time	t_{CEZ}		40		50	ns	5
\overline{OE} to DQ Low-Z	t_{OEL}	5		5		ns	5
\overline{OE} Access Time	t_{OEA}		100		130	ns	5
\overline{OE} Data Off Time	t_{OEZ}		35		35	ns	5
Output Hold from Address	t_{OH}	5		5		ns	5

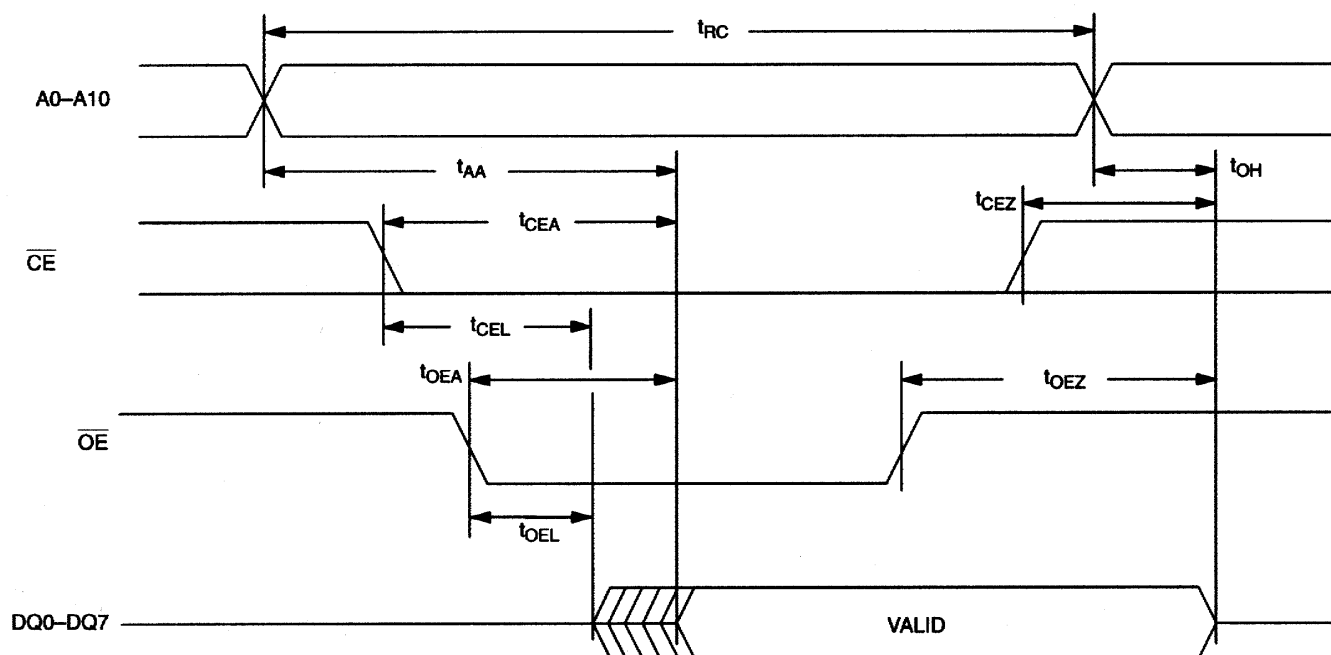
READ CYCLE TIMING DIAGRAM

WRITE CYCLE, AC CHARACTERISTICS (0°C to 70°C; $V_{CC} = 5.0V \pm 10\%$)

PARAMETER	SYMBOL	70 ns access		100 ns access		UNITS	NOTES
		MIN	MAX	MIN	MAX		
Write Cycle Time	t_{WC}	70		100		ns	
Address Access Time	t_{AS}	0		0		ns	
\overline{WE} Pulse Width	t_{WEW}	50		70		ns	
\overline{CE} Pulse Width	t_{CEW}	60		75		ns	
Data Setup Time	t_{DS}	30		40		ns	
Data Hold time	t_{DH}	0		0		ns	
Address Hold Time	t_{AH}	5		5		ns	
\overline{WE} Data Off Time	t_{WEZ}		25		35	ns	
Write Recovery Time	t_{WR}	5		5		ns	

WRITE CYCLE, AC CHARACTERISTICS (0°C to 70°C; $V_{CC} = 3.3V \pm 10\%$)

PARAMETER	SYMBOL	120 ns access		150 ns access		UNITS	NOTES
		MIN	MAX	MIN	MAX		
Write Cycle Time	t_{WC}	120		150		ns	
Address Setup Time	t_{AS}	0		0		ns	
\overline{WE} Pulse Width	t_{WEW}	100		130		ns	
\overline{CE} Pulse Width	t_{CEW}	110		140		ns	
Data Setup Time	t_{DS}	80		90		ns	
Data Hold Time	t_{DH}	0		0		ns	
Address Hold Time	t_{AH}	0		0		ns	
\overline{WE} Data Off Time	t_{WEZ}		40		50	ns	
Write Recovery Time	t_{WR}	10		10		ns	

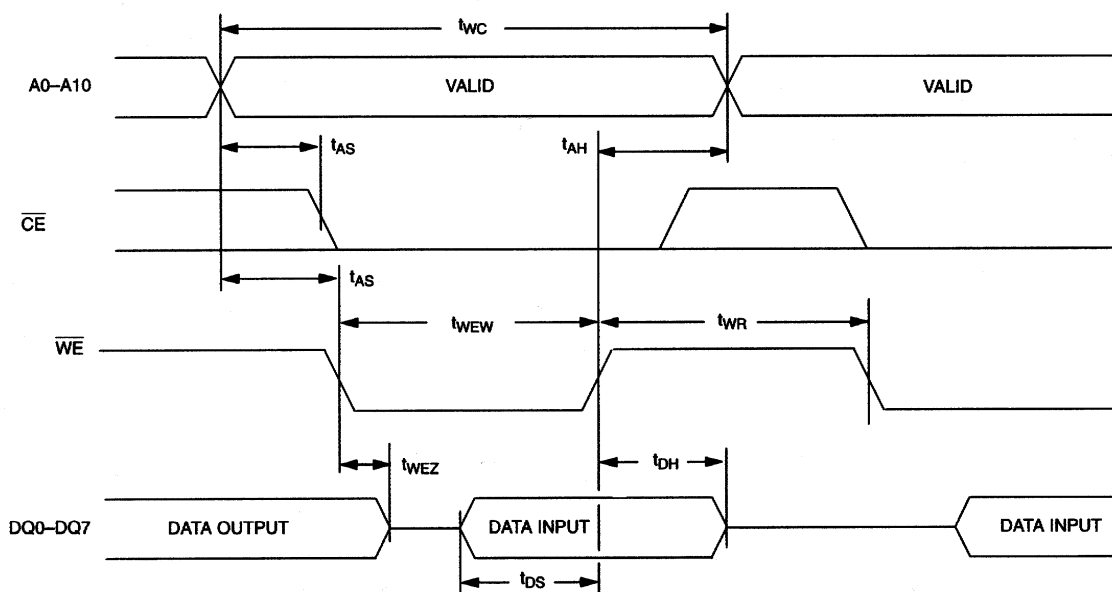
WRITE CYCLE TIMING DIAGRAM, WRITE ENABLE CONTROLLED

WRITE CYCLE TIMING DIAGRAM, CE CONTROLLED

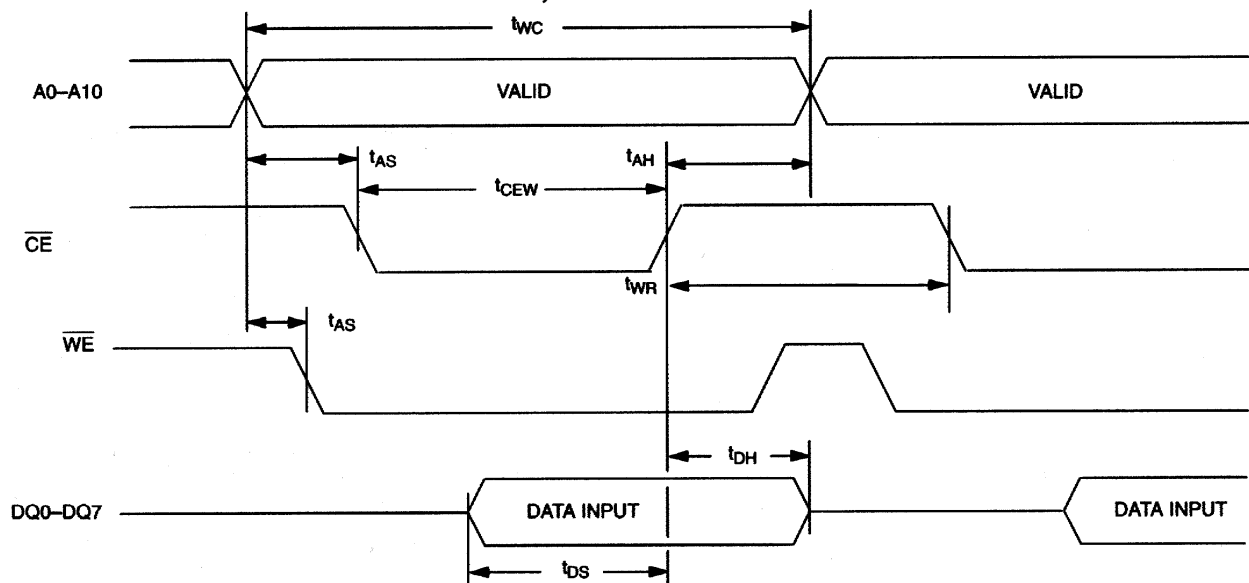

POWER-UP/DOWN CHARACTERISTICS (0°C to 70°C; V_{CC} = 5.0V ±10%)

PARAMETER	SYMBOL	MIN	TYP	MAX	UNITS	NOTES
$\overline{\text{CE}}$ or $\overline{\text{WE}}$ at V _{IH} , Before Power-Down	t _{PD}	0			μs	
V _{CC} Fall Time: V _{PF(MAX)} to V _{PF(MIN)}	t _F	300			μs	
V _{CC} Fall Time: V _{PF(MIN)} to V _{SO}	t _{FB}	10			μs	
V _{CC} Rise Time: V _{PF(MIN)} to V _{PF(MAX)}	t _R	0			μs	
Power-up Recover Time	t _{REC}			35	ms	
Expected Data Retention Time (Oscillator On)	t _{DR}	10			years	5, 6

POWER-UP/DOWN WAVEFORM TIMING 5-VOLT DEVICE

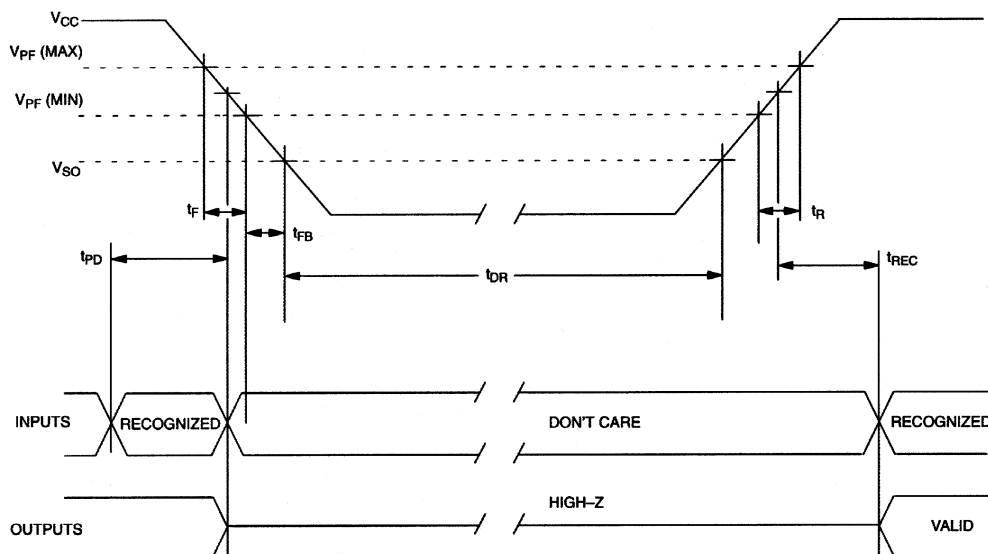

POWER-UP/DOWN CHARACTERISTICS (0°C to 70°C; $V_{CC} = 3.3V \pm 10\%$)

PARAMETER	SYMBOL	MIN	TYP	MAX	UNITS	NOTES
\overline{CE} or \overline{WE} at V_{IH} , Before Power-Down	t_{PD}	0			μs	
V_{CC} Fall Time: $V_{PF(MAX)}$ to $V_{PF(MIN)}$	t_F	300			μs	
V_{CC} Rise Time: $V_{PF(MIN)}$ to $V_{PF(MAX)}$	t_R	0			μs	
Power-up Recovery Time	t_{REC}			35	ms	
Expected Data Retention Time (Oscillator On)	t_{DR}	10			years	5, 6

POWER-UP/DOWN WAVEFORM TIMING 3.3-VOLT DEVICE

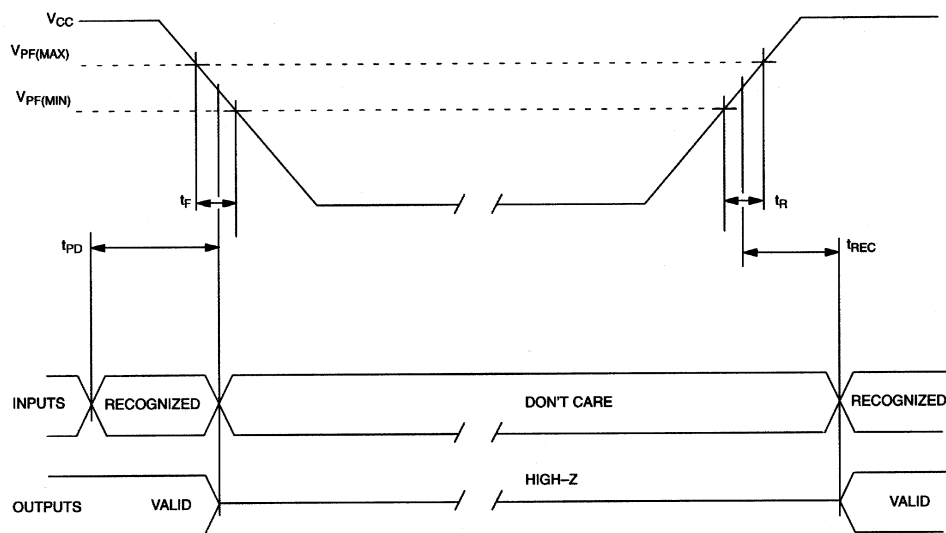

CAPACITANCE

(T_A = 25°C)

PARAMETER	SYMBOL	MIN	TYP	MAX	UNITS	NOTES
Capacitance on all input pins	C_{IN}			7	pF	
Capacitance on all output pins	C_O			10	pF	

AC TEST CONDITIONS

Output Load: 100 pF + 1TTL Gate

Input Pulse Levels: 0.0 to 3.0 Volts

Timing Measurement Reference Levels:

Input: 1.5V

Output: 1.5V

Input Pulse Rise and Fall Times: 5 ns

NOTES:

1. Voltage referenced to ground.
2. Typical values are at 25 °C and nominal supplies.
3. Outputs are open.
4. Battery switch-over occurs at the lower of either the battery voltage or V_{PF} .
5. Data retention time is at 25 °C.
6. Each DS1742 has a built-in switch that disconnects the lithium source until V_{CC} is first applied by the user. The expected t_{DR} is defined as a cumulative time in the absence of V_{CC} starting from the time power is first applied by the user.
7. Real Time Clock Modules can be successfully processed through conventional wave-soldering techniques as long as temperature exposure to the lithium energy source contained within does not exceed +85°C. Post-solder cleaning with water washing techniques is acceptable, provided that ultrasonic vibration is not used to prevent damage to the crystal.

DS1742 24-PIN PACKAGE

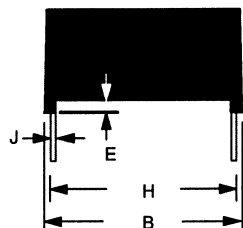
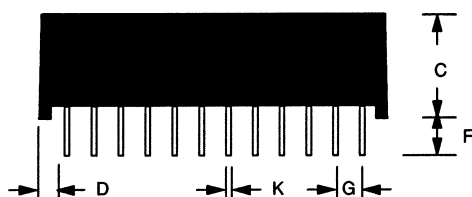
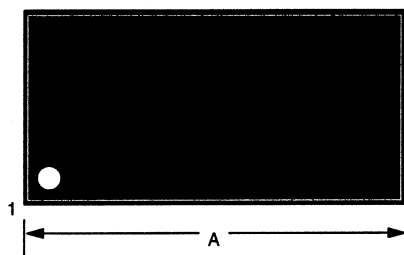

PKG	24-PIN	
	DIM	MIN
A IN.	1.270	1.290
MM	37.34	37.85
B IN.	0.675	0.700
MM	17.15	17.78
C IN.	0.315	0.335
MM	8.00	8.51
D IN.	0.075	0.105
MM	1.91	2.67
E IN.	0.015	0.030
MM	0.38	0.76
F IN.	0.140	0.180
MM	3.56	4.57
G IN.	0.090	0.110
MM	2.29	2.79
H IN.	0.590	0.630
MM	14.99	16.00
J IN.	0.010	0.018
MM	0.25	0.45
K IN.	0.015	0.025
MM	0.43	0.58