

TOSHIBA PHOTOINTERRUPTER INFRARED LED + PHOTOTRANSISTOR

# TLP836

STILL CAMERA

VIDEO CAMERA

FLOPPY DISK DRIVE

SMALL-SIZED PERSONAL OA EQUIPMENT

TLP836 is a photointerrupter consisting of a GaAs infrared LED and an Si phototransistor. It has a narrow slit and a high resolution.

- Very small package
- Printed circuit board direct mounting type
- Gap : 1mm
- High resolution :  
slit width .. 0.15mm (infrared LED side)  
0.1mm (phototransistor side)

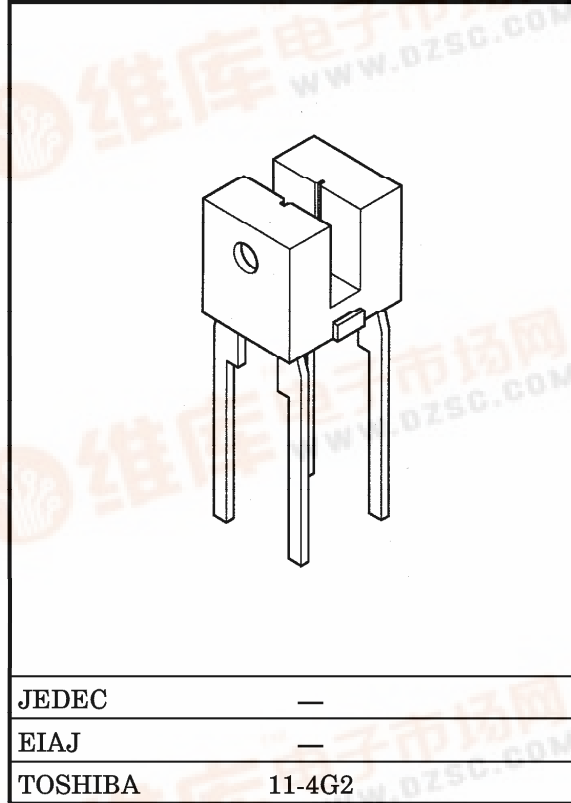

JEDEC	—
EIAJ	—
TOSHIBA	11-4G2

MAXIMUM RATINGS (Ta = 25°C)

Weight : 0.09g (typ.)

CHARACTERISTIC		SYMBOL	RATING	UNIT
LED	Forward Current	I <sub>F</sub>	50	mA
	Forward Current Derating (Ta > 25°C)	ΔI <sub>F</sub> /°C	-0.67	mA/°C
	Reverse Voltage	V <sub>R</sub>	5	V
DETECTOR	Collector-Emitter Voltage	V <sub>CEO</sub>	35	V
	Emitter-Collector Voltage	V <sub>ECO</sub>	5	V
	Collector Power Dissipation	P <sub>C</sub>	75	mW
	Collector Power Dissipation Derating (Ta > 25°C)	ΔP <sub>C</sub> /°C	-1	mW/°C
	Collector Current	I <sub>C</sub>	20	mA
Operating Temperature Range		T <sub>opr</sub>	-25~85	°C
Storage Temperature Range		T <sub>stg</sub>	-40~100	°C
Soldering Temperature (5s, Note 1)		T <sub>sol</sub>	260	°C

Note 1 : At the location of 1.5mm from the resin package bottom



RECOMMENDED OPERATING CONDITIONS

CHARACTERISTIC	SYMBOL	MIN.	TYP.	MAX.	UNIT
Supply Voltage	$V_{CC}$	—	—	24	V
Forward Current	$I_F$	—	—	20	mA

OPTO-ELECTRICAL CHARACTERISTICS (Ta = 25°C)

CHARACTERISTIC		SYMBOL	TEST CONDITION	MIN.	TYP.	MAX.	UNIT
LED	Forward Voltage	$V_F$	$I_F = 10\text{mA}$	1.00	1.15	1.30	V
	Reverse Current	$I_R$	$V_R = 5\text{V}$	—	—	10	$\mu\text{A}$
	Peak Emission Wavelength	$\lambda_P$	$I_F = 10\text{mA}$	—	940	—	nm
DETECTOR	Dark Current	$I_D (I_{CEO})$	$V_{CE} = 24\text{V}$	—	—	0.1	$\mu\text{A}$
	Peak Sensitivity Wavelength	$\lambda_P$	—	—	800	—	nm
COUPLED	Current Transfer Ratio	$I_C / I_F$	$V_{CE} = 5\text{V}, I_F = 10\text{mA}$	0.27	1.2	—	%
	Collector-Emitter Saturation Voltage	$V_{CE}(\text{sat})$	$I_F = 20\text{mA}, I_C = 27\mu\text{A}$	—	—	0.4	V
	Switching Time	Rise Time	$t_r$	$V_{CC} = 5\text{V}, I_C = 2\text{mA}$ $R_L = 100\Omega$ (Note 2)	—	4	—
Fall Time		$t_f$	—		5	—	

Note 2 : Switching time measurement circuit and waveform

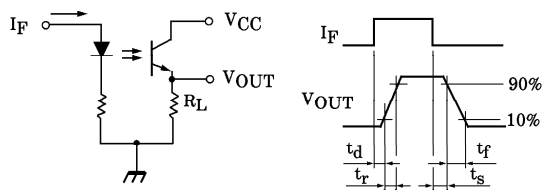

PRECAUTIONS

- When removing flux with chemicals after soldering, clean only the leads on the soldering side; do not dip the whole package for cleaning. Chemicals remaining on an LED or photo transistor light emitter or receiver, if any, would have a bad influence to the optical characteristics and it may severely lower the conversion efficiency.
- The environment to install the device should be determined carefully. Oil or chemicals may cause the package to be dissolved or cracked.
- The device should be mounted on an unwarped surface.
- The current transfer ratio is gradually lowered when infrared LED is powered. The efficiency deterioration by aging should be considered when designing the circuit.
- Stress causing the package deformation or deterioration should not be given to the package.

961001EBC2'

● Gallium arsenide (GaAs) is a substance used in the products described in this document. GaAs dust and fumes are toxic. Do not break, cut or pulverize the product, or use chemicals to dissolve them. When disposing of the products, follow the appropriate regulations. Do not dispose of the products with other industrial waste or with domestic garbage.  
 ● The products described in this document are subject to foreign exchange and foreign trade control laws.  
 ● The information contained herein is presented only as a guide for the applications of our products. No responsibility is assumed by TOSHIBA CORPORATION for any infringements of intellectual property or other rights of the third parties which may result from its use. No license is granted by implication or otherwise under any intellectual property or other rights of TOSHIBA CORPORATION or others.  
 ● The information contained herein is subject to change without notice.

OUTLINE : TOSHIBA

Unit : mm

Tolerance :  $\pm 0.2\text{mm}$  unless otherwise specified

Values in parentheses ( ) are for reference.

The remaining gate should be 0.2mm or less.

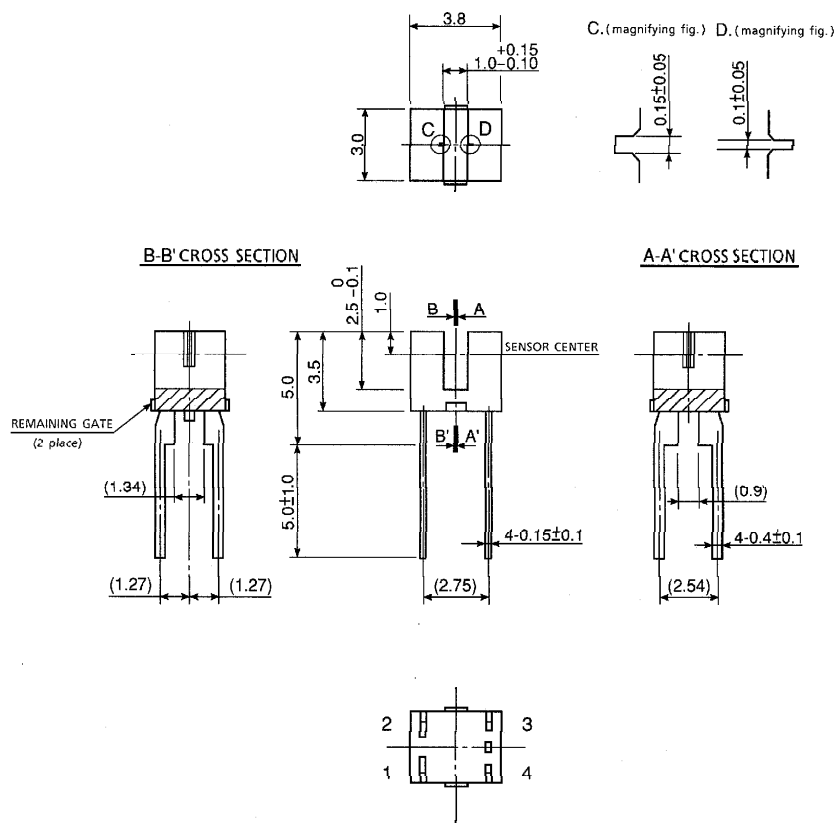

Weight : 0.09g (typ.)

**PIN CONNECTION**

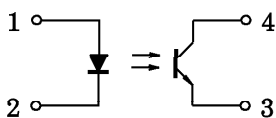

1. ANODE
2. CATHODE
3. EMITTER
4. COLLECTOR

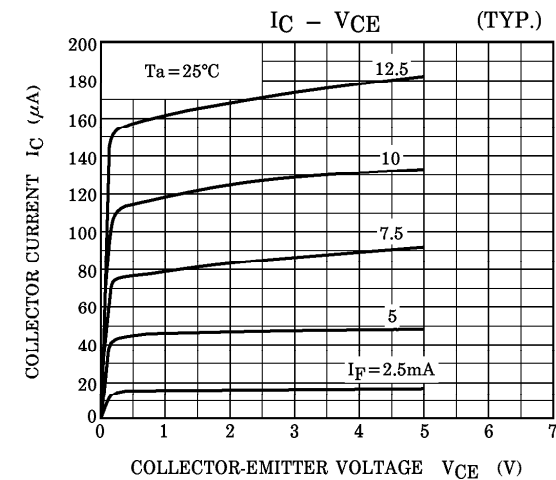
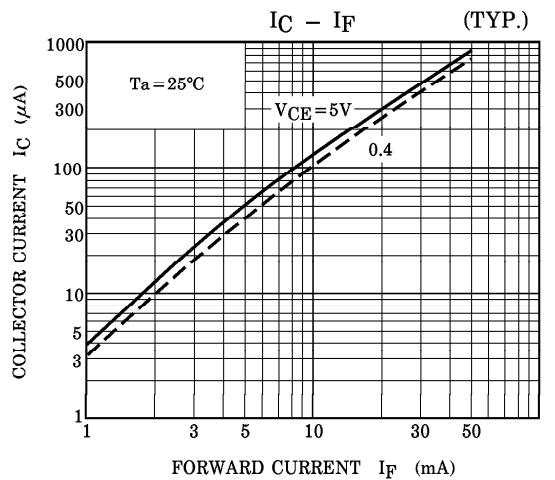
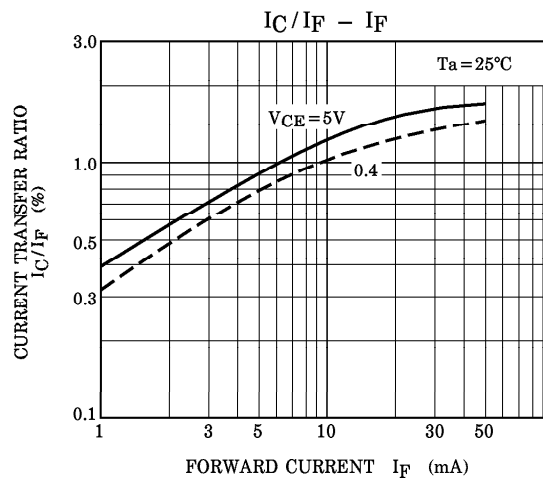
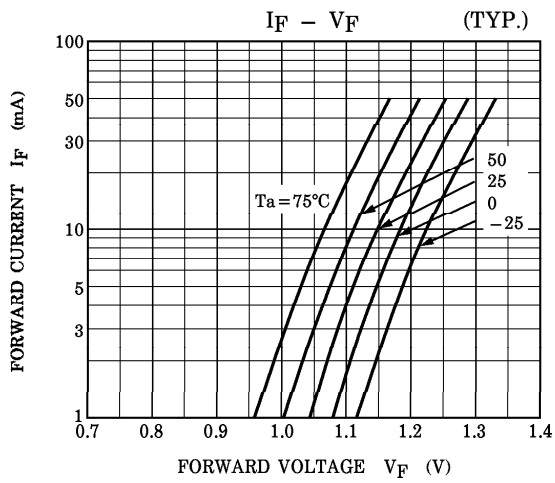
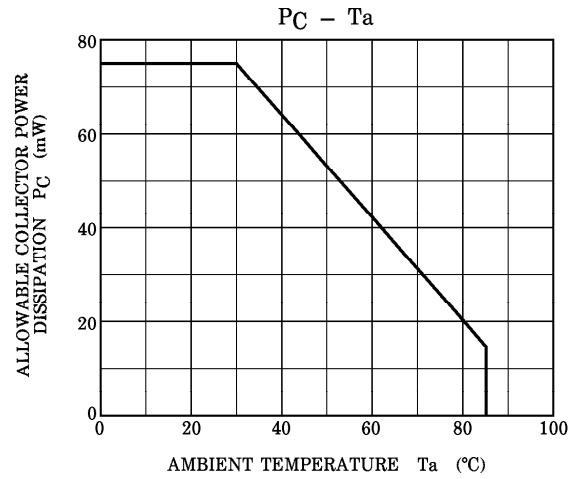
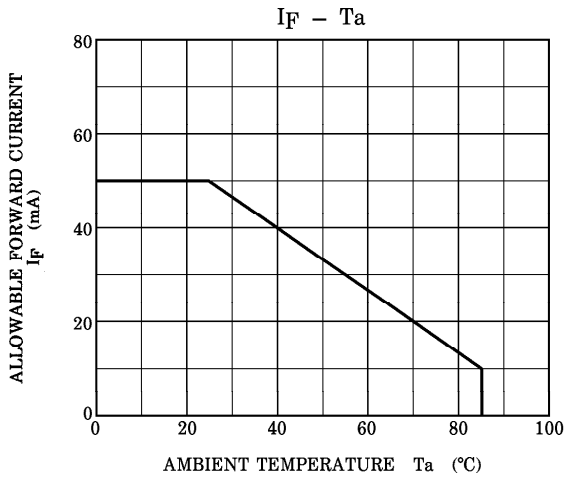

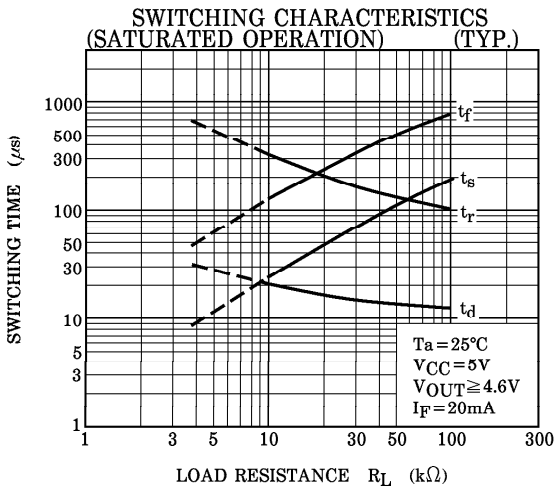
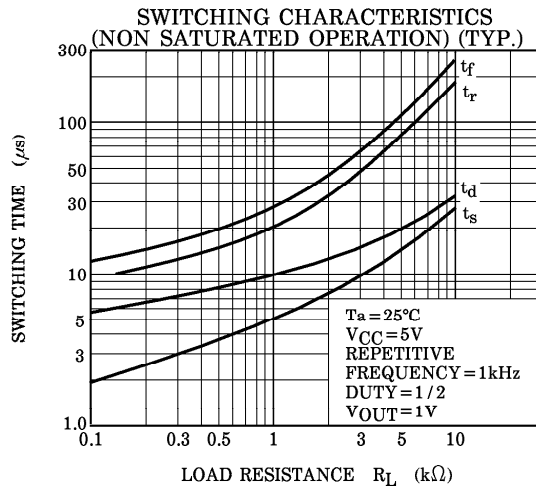
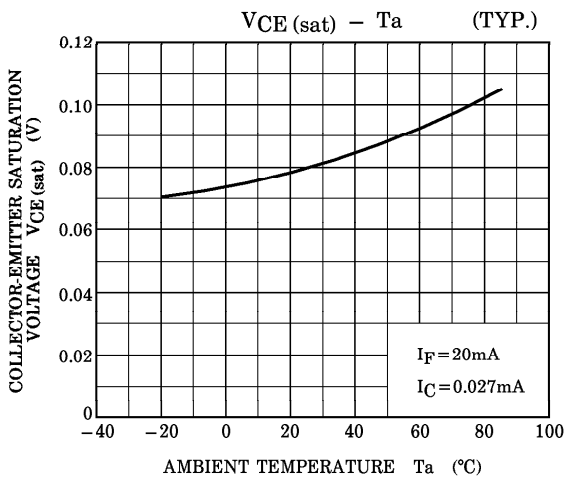
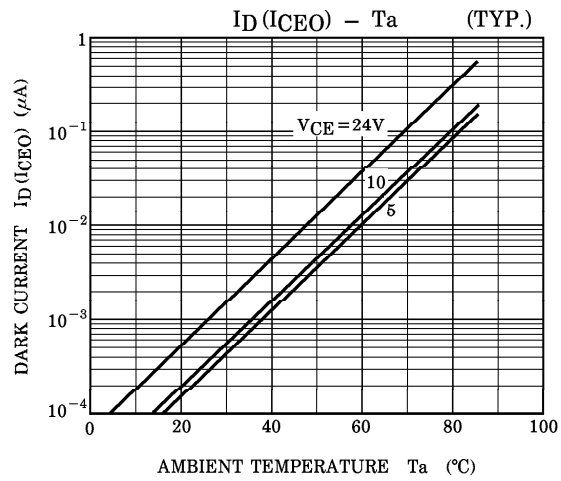
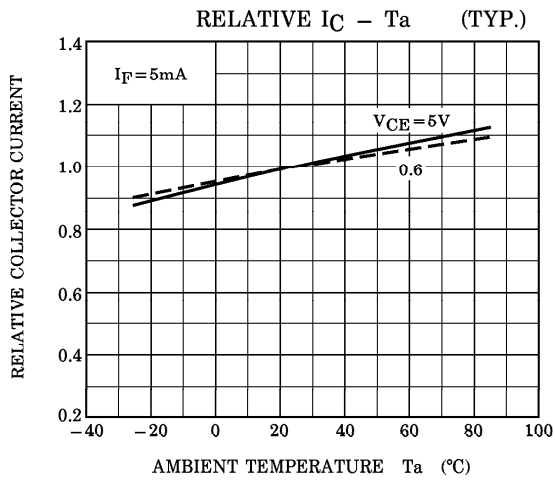

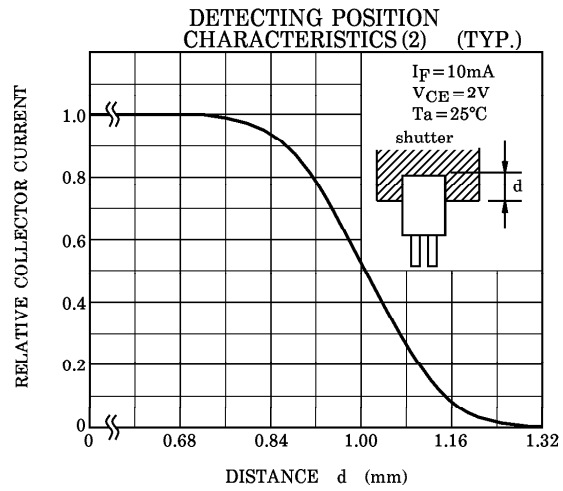
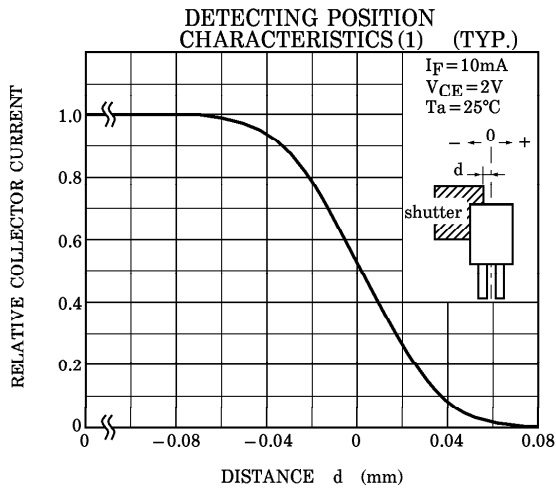

**POSITIONING OF SHUTTER AND DEVICE**

To operate correctly, make sure that the shutter and the device are positioned as shown in the figure below.

The slit pitch of the shutter must be set wider than the slit width of the device.  
 Determine the width taking the switching time into consideration.

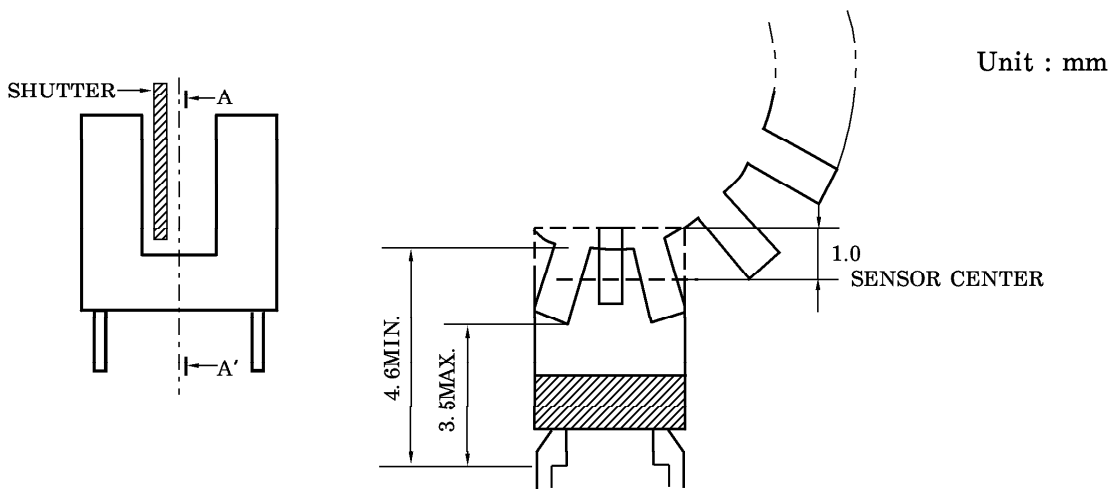

**A-A' CROSS SECTION**