

FIBER OPTIC TRANSMITTING MODULE

**TOED100**

FIBER OPTIC TRANSMITTING MODULE FOR MIDDLE DISTANCE TRANSMISSION

Unit : mm

- Data rate : DC to 20 Mb/s (NRZ code)
- Digital data transmission with the external circuit.
- JIS F01 (FC) type fiber optic connector.
- Transmission distance :  
0.2 to 2000 m ( $I_F = 50 \text{ mA}$ )  
0.2 to 1500 m (Using TA8513P)

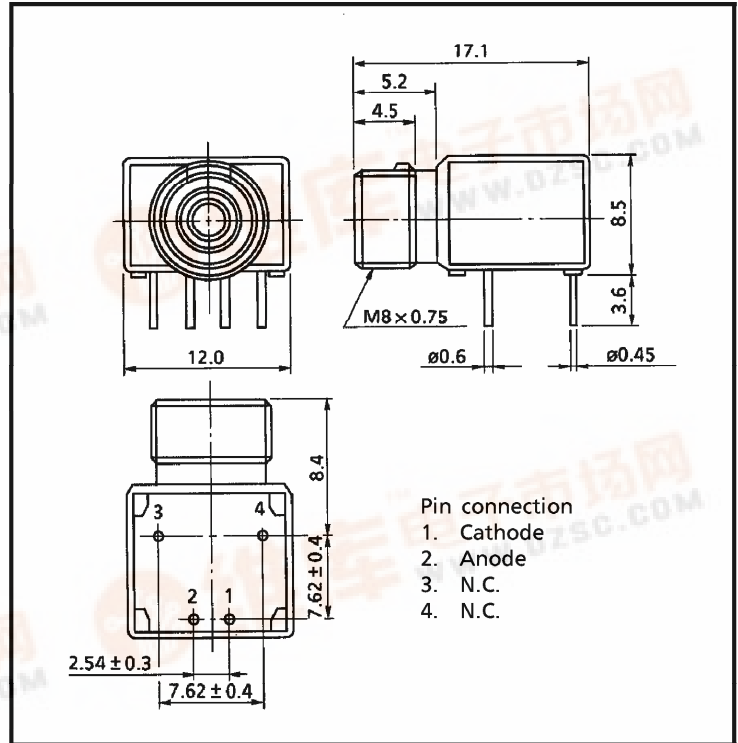

1. Maximum Ratings ( $T_a = 25^\circ\text{C}$ )

PARAMETER	SYMBOL	RATINGS	UNIT
Storage Temperature	$T_{stg}$	-40 ~ 85	$^\circ\text{C}$
Operating Temperature	$T_{opr}$	-40 ~ 85	$^\circ\text{C}$
Forward Current (DC)	$I_{FDC}$	MAX 75	mA
Forward Current (Pulse) <sup>(1)</sup>	$I_{FPK}$	MAX 120	mA
Reverse Voltage	$V_R$	MAX. 3	V
Soldering Temperature	$T_{sol}$	260 <sup>(2)</sup>	$^\circ\text{C}$

Note <sup>(1)</sup> Frequency 100 kHz, Duty cycle 50%.

<sup>(2)</sup> Soldering time  $\leq 3 \text{ s}$  (More than 1 mm apart from the package).

2. Recommended Operating Conditions

PARAMETER	SYMBOL	MIN	TYP.	MAX	UNIT
Forward Current	$I_F$	20	—	75	mA

Handling precaution : The LEDs used in this product contain GaAs (Gallium Arsenide). Care must be taken to protect the safety of people and the environment when scrapping or terminal processing.

961001EAC2

- TOSHIBA is continually working to improve the quality and the reliability of its products. Nevertheless, semiconductor devices in general can malfunction or fail due to their inherent electrical sensitivity and vulnerability to physical stress. It is the responsibility of the buyer, when utilizing TOSHIBA products, to observe standards of safety, and to avoid situations in which a malfunction or failure of a TOSHIBA product could cause loss of human life, bodily injury or damage to property. In developing your designs, please ensure that TOSHIBA products are used within specified operating ranges as set forth in the most recent products specifications. Also, please keep in mind the precautions and conditions set forth in the TOSHIBA Semiconductor Reliability Handbook.
- Gallium arsenide (GaAs) is a substance used in the products described in this document. GaAs dust and fumes are toxic. Do not break, cut or pulverize the product, or use chemicals to dissolve them. When disposing of the products, follow the appropriate regulations. Do not dispose of the products with other industrial waste or with domestic garbage.
- The information contained herein is presented only as a guide for the applications of our products. No responsibility is assumed by TOSHIBA CORPORATION for any infringements of intellectual property or other rights of the third parties which may result from its use. No license is granted by implication or otherwise under any intellectual property or other rights of TOSHIBA CORPORATION or others.
- The information contained herein is subject to change without notice.

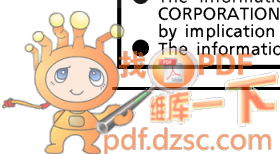

3. Electrical and Optical Characteristics (Ta = 25°C, VCC = 5 V)

PARAMETER	SYMBOL	CONDITIONS	MIN	TYP.	MAX	UNIT
Data Rate		NRZ code <sup>(3)</sup>	DC	—	20	Mb/s
Transmission Distance		I <sub>F</sub> = 50 mA	0.2	—	2000	m
		Using TA8513P	0.2	—	1500	m
Pulse Width Distortion	Δtw	C <sub>L</sub> = 10 pF <sup>(4)</sup>	-25	—	25	ns
Fiber Output Power	P <sub>f</sub>	I <sub>F</sub> = 50 mA <sup>(5)</sup>	-20	—	-17	dBm
Peak Emission Wavelength	λ <sub>p</sub>	I <sub>F</sub> = 50 mA	780	850	880	nm
Cut-off Frequency	f <sub>c</sub>	I <sub>F</sub> = 25 mA (-3 dB)	20	35	—	MHz
Forward Voltage	V <sub>F</sub>	I <sub>F</sub> = 50 mA	—	1.6	2.0	V
Reverse Current	I <sub>R</sub>	V <sub>R</sub> = 3 V	—	—	10	μA

<sup>(3)</sup> Duty cycle 25~75%. Using TORX100.

<sup>(4)</sup> Pulse width 50 ns, pulse cycle 100 ns. Between input of TA8513P and output of TORX100.

<sup>(5)</sup> Measure with a standard fiber optical connectors. Valued by peak value.

4. Application Circuit

a) Driving TOED100 by TA8513P (resistor change).

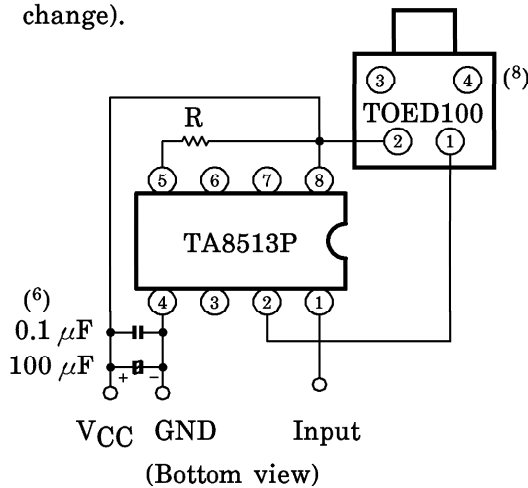

Change external resistor R according to the transmission distance.

TRANSMISSION DISTANCE (m)	RESISTOR VALUE (Ω)
0.2 ~ 750	1.2 k
750 ~ 1300	300
1300 ~ 1500	0 <sup>(7)</sup>

b) Designing TOED100 driving circuit with constant I<sub>F</sub> value.

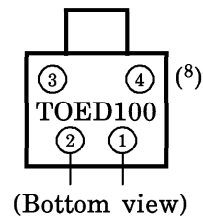

Set the I<sub>F</sub> value to that given in the table below according to the transmission distance (within ±5%).

TRANSMISSION DISTANCE (m)	I <sub>F</sub> (mA)
0.2 ~ 1000	30
1000 ~ 2000	50

<sup>(6)</sup> Connect the 0.1 μF capacitor within 5 mm and the 100 μF capacitor within 15 mm of TA8513P pin 8.

<sup>(7)</sup> Connect also pin 7 to VCC only in this case.

<sup>(8)</sup> Solder TOED100 pins 3 and 4 to the printed circuit board.

c) Driving TOED100 by TA8513P (pin change).

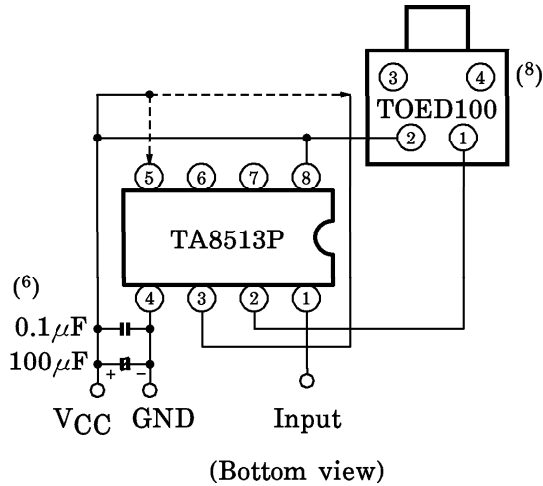

Change the connected pin of TA8513P according to the transmission distance.

TRANSMISSION DISTANCE (m)	Pin No. (CONNECT V <sub>CC</sub> )
0.2 ~ 750	③
750 ~ 1200	⑤

- (6) Connect the 0.1  $\mu\text{F}$  capacitor within 5mm and the 100  $\mu\text{F}$  capacitor within 15 mm of TA8513P pin 8.
- (8) Solder TOED100 pins 3 and 4 to the printed circuit board.

○ Example of Typical Characteristics <sup>(9)</sup>

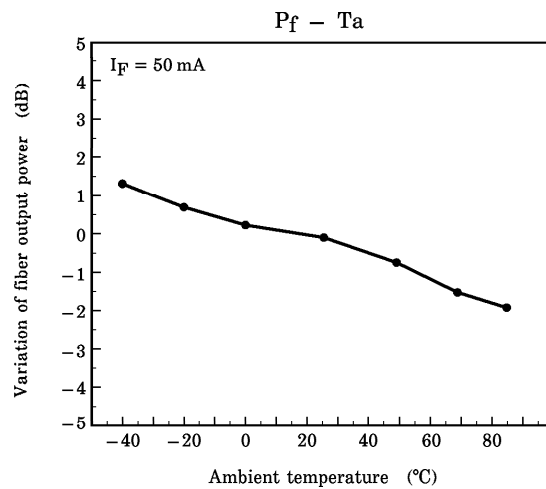
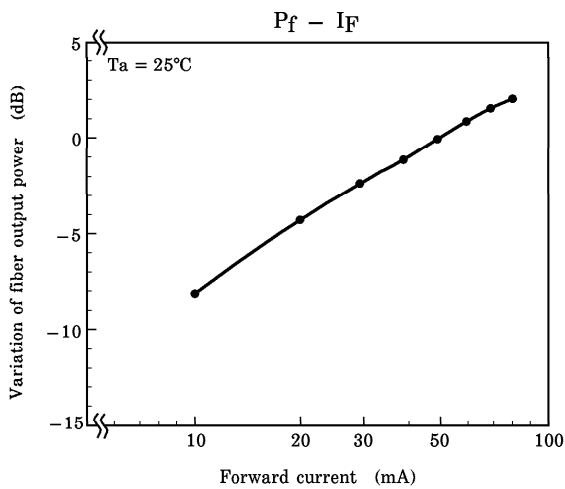

<sup>(9)</sup> There give characteristic examples, and its values are not guaranteed.

## 5. Pin Layout

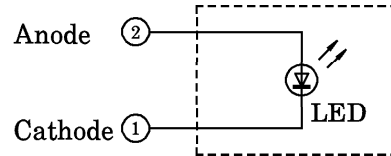

## 6. Applicable fiber optic connectors.

JIS F01 (FC) type fiber optic connector (with 50 / 125  $\mu\text{m}$  GI fiber, Transmission Loss  $\leq 3$  dB / km).

## 7. Precautions during use

### (1) Maximum rating

The maximum ratings are the limit values which must not be exceeded during operation of device. None of these rating value must not be exceeded. If the maximum rating value is exceeded, the characteristics of devices may never be restored properly. In extreme cases, the device may be permanently damages.

### (2) Lifetime of light emitters

If an optical module is used for a long period of time, degeneration in the characteristics will mostly be due to a lowering of the fiber output power (Pf). This is caused by the degradation of the optical output of the LEDs used as the light source. The cause of degradation of the optical output of the LEDs may be defects in wafer crystallization or mold resin stress. The detailed causes are, however, not clear.

The lifetime of light emitters is greatly influenced by the operating conditions and the environment in which it is used as well as by the lifetime characteristics unique to the device type. Thus, when a light emitting device and its operating conditions determined, Toshiba recommend that lifetime characteristics be checked.

Depending on the environment conditions, Toshiba recommend that maintenance such as regular checks of the amount of optical output in accordance with the condition of operating environment.

### (3) Soldering

Optical modules are comprised of internal semiconductor devices. However, in principle, optical modules are optical components. During soldering, ensure that flux does not contact with the emitting surface or the detecting surface. Also ensure that proper flux removal is conducted after soldering.

Some optical modules come with a protective cap. The protective cap is used to avoid malfunction when the optical module is not in use. Note that it is not dust or waterproof. As mentioned before, optical modules are optical components. Thus, in principle, soldering where there may be flux residue and flux removal after soldering is not recommended. Toshiba recommend that soldering be performed without the optical module mounted on the board. Then, after the board has been cleaned, the optical module should be soldered on to the board manually.

If the optical module cannot be soldered manually, use non-halogen (chlorine-free) flux and make sure, without cleaning, there is no residue such as chlorine. This is one of the ways to eliminate the effects of flux. In such a cases, be sure to check the devices' reliability.

### (4) Vibration and shock

This module is a can type package which internal device is hollow so that the wire is not fixed to the device. This structure is not relatively sound against vibration and shock. Attention must be paid to the design of the mechanism for applications which are subject to large amounts of vibration.

(5) Fixing fiber optical transmitting module

Solder the fixed pin (pins 3 and 4) of fiber optic transmitting module TOED100 to the printed circuit board to fix the module to the board.

(6) Solvent

When using solvent for flux removal, do not use a high acid or high alkali solvent. Be careful not to pour solvent in to the optical connector ports. If solvent is inadvertently poured in to them, clean it off using cotton tips.

(7) Protective cap

When the TOED100 is not in use, attach the protective cap.

(8) Soldering condition

Solder at 260°C or less for no more than three seconds.

(9) Precautions when disposing of devices and packing materials.

When disposing devices and packing materials, follow the procedures stipulated by local regulations in order to protect the environment against contamination.

Compound semiconductors such as GaAs are used as LED materials in this module. When devices are disposed of, worker safety and protection of the environment must be taken into account.

(10) Precautions during use

Toshiba is continually working to improve the quality and the reliability of their products. Nevertheless, semiconductor devices in general can malfunction or fail due to their inherent electrical sensitivity and their vulnerability to physical stress. It is the responsibility of the buyer, when utilizing Toshiba products, to observe standards of safety, and to avoid situations in which the malfunction or failure of a Toshiba product could cause loss of human life, bodily injury or damage to property.

When developing equipment, please ensure that Toshiba products are used within the specified operating ranges set forth in the most recent product specifications. Also, please keep in mind the precautions and conditions set forth in the Toshiba Semiconductor Reliability Handbook.