

TOSHIBA

TPS826

TOSHIBA PHOTO IC SILICON EPITAXIAL PLANAR

TPS826

PHOTO IC FOR PLASTIC FIBER / POLYMER CLAD FIBER

Unit in mm

TPS826 contains a light receiving IC integrating photo diode, amplifier circuit, open waveform shaping circuit, etc. in 1 chip.

Output is directly connectable to IC as it changes digitally.

When light is received, output becomes low level.

- Compatible with TTL, LSTTL and CMOS.
- Wide operating supply voltage ($V_{CC}=4.5$ to $17V$)

MAXIMUM RATINGS

CHARACTERISTIC	SYMBOL	RATING	UNIT
Supply Voltage	V_{CC}	17	V
Low Level Output Current	I_{OL}	50	mA
Allowable Power Dissipation	P_O	250	mW
Operating Temperature Range	T_{opr}	-25~85	°C
Storage Temperature Range	T_{stg}	-40~100	°C
Soldering Temperature Time	T_{sol}	260°C · 3s	

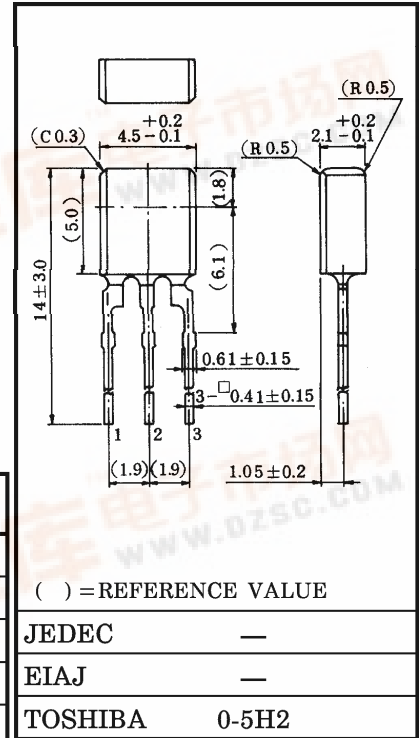

PIN CONNECTION

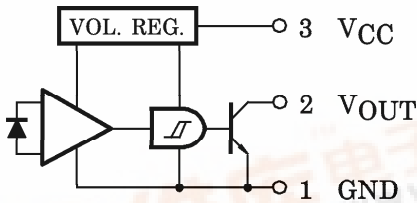

961001EAA2

- TOSHIBA is continually working to improve the quality and the reliability of its products. Nevertheless, semiconductor devices in general can malfunction or fail due to their inherent electrical sensitivity and vulnerability to physical stress. It is the responsibility of the buyer, when utilizing TOSHIBA products, to observe standards of safety, and to avoid situations in which a malfunction or failure of a TOSHIBA product could cause loss of human life, bodily injury or damage to property. In developing your designs, please ensure that TOSHIBA products are used within specified operating ranges as set forth in the most recent products specifications. Also, please keep in mind the precautions and conditions set forth in the TOSHIBA Semiconductor Reliability Handbook.
- The information contained herein is presented only as a guide for the applications of our products. No responsibility is assumed by TOSHIBA CORPORATION for any infringements of intellectual property or other rights of the third parties which may result from its use. No license is granted by implication or otherwise under any intellectual property or other rights of TOSHIBA CORPORATION or others.
- The information contained herein is subject to change without notice.

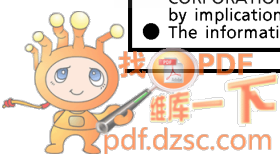

OPTO-ELECTRICAL CHARACTERISTICS (Ta = 25°C)

CHARACTERISTIC		SYMBOL	TEST CONDITION	MIN.	TYP.	MAX.	UNIT
Operating Supply Voltage		V _{CC}	Ta = 25°C	4.5	—	17	V
Output Current	Low Level	V _{OL}	I _{OL} = 16mA, V _{CC} = 5V P _f = 50μW	—	0.1	0.4	V
	High Level	V _{OH}	V _{CC} = 5V	4.0	—	—	
Supply Current	Low Level	I _{CCL}	V _{CC} = 5V, P _f = 50μW	—	2.5	5.0	mA
	High Level	I _{CCH}	V _{CC} = 5V	—	1.2	3.0	
H→L Threshold Light Input (Note)		P _{fHL}	V _{CC} = 5V, Ta = 25°C, λ _p = 660nm	—	5.0	10.0	μW
				—	-23	-20	dBm
Switching Time	Propagation Time	L→H	t _{pLH}	—	6.0	—	μs
		H→L	t _{pHL}	—	2.0	—	
	Rise Time		t _r	—	0.1	—	
	Fall Time		t _f	—	0.03	—	
			Ta = 25°C, V _{CC} = 5V, R _L = 280Ω, P _f = 0↔50μW				

Note : Equivalent to the optical output at the end of a plastic fiber in the core diameter 1mm.

SWITCHING TIME TEST CIRCUIT

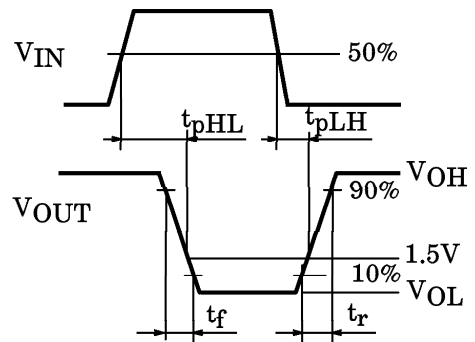
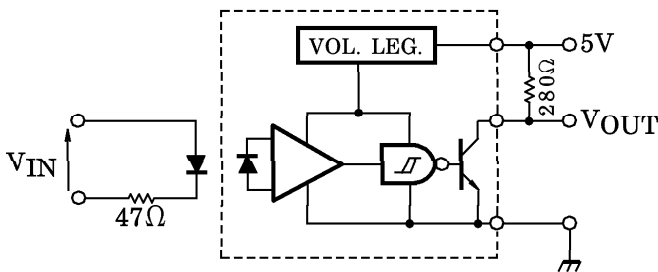

PRECAUTION

Please be careful of the followings.

- Lead forming shall be performed before soldering.
(Soldering portion of lead : above 1.5mm from the body of the device)
- During 100μs after turning on V_{CC}, output voltage changes for stabilizing the inner circuit.
- Pin surge voltage (Note) : MAX 150V

Note : Surge voltage chargeable between optional 2 pins at storage charge below 200pF.

