

TOSHIBA

TA2066F/FN

TOSHIBA BIPOLAR LINEAR INTEGRATED CIRCUIT SILICON MONOLITHIC

TA2066F, TA2066FN

RF AMPLIFIER FOR DIGITAL SERVO CD SYSTEM

TA2066F/FN is a 3-beam type PUH compatible RF Amplifier to be used in the CD system. In combination with a CMOS single chip processor TC9296AF/TC9405F/TC9406F, a CD system can be composed very simply.

FEATURES

- Built in amplifier for reference supply
- Built in Auto Laser Power Control circuit
- Built in RF amplifier
- Built in focus error amp, and tracking error amp
- Built in sub-beam adder signal amplifier
- Capable of tracking balance control with TC9296AF/TC9405F/TC9406F
- Low power decimation
- Capable of Double speed operation and quadruple operation

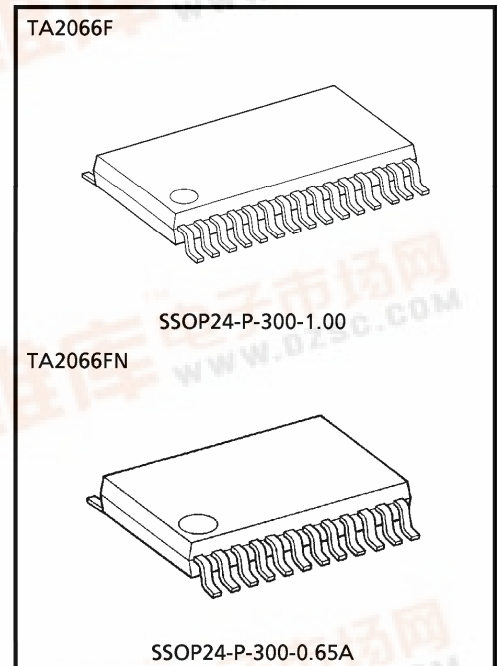

Weight
 SSOP24-P-300-1.00 : 0.3 g (Typ.)
 SSOP24-P-300-0.65A : 0.17 g (Typ.)

980910EBA1

- TOSHIBA is continually working to improve the quality and the reliability of its products. Nevertheless, semiconductor devices in general can malfunction or fail due to their inherent electrical sensitivity and vulnerability to physical stress. It is the responsibility of the buyer, when utilizing TOSHIBA products, to observe standards of safety, and to avoid situations in which a malfunction or failure of a TOSHIBA product could cause loss of human life, bodily injury or damage to property. In developing your designs, please ensure that TOSHIBA products are used within specified operating ranges as set forth in the most recent products specifications. Also, please keep in mind the precautions and conditions set forth in the TOSHIBA Semiconductor Reliability Handbook.
- The products described in this document are subject to the foreign exchange and foreign trade laws.
- The information contained herein is presented only as a guide for the applications of our products. No responsibility is assumed by TOSHIBA CORPORATION for any infringements of intellectual property or other rights of the third parties which may result from its use. No license is granted by implication or otherwise under any intellectual property or other rights of TOSHIBA CORPORATION or others.
- The information contained herein is subject to change without notice.



BLOCK DIAGRAM

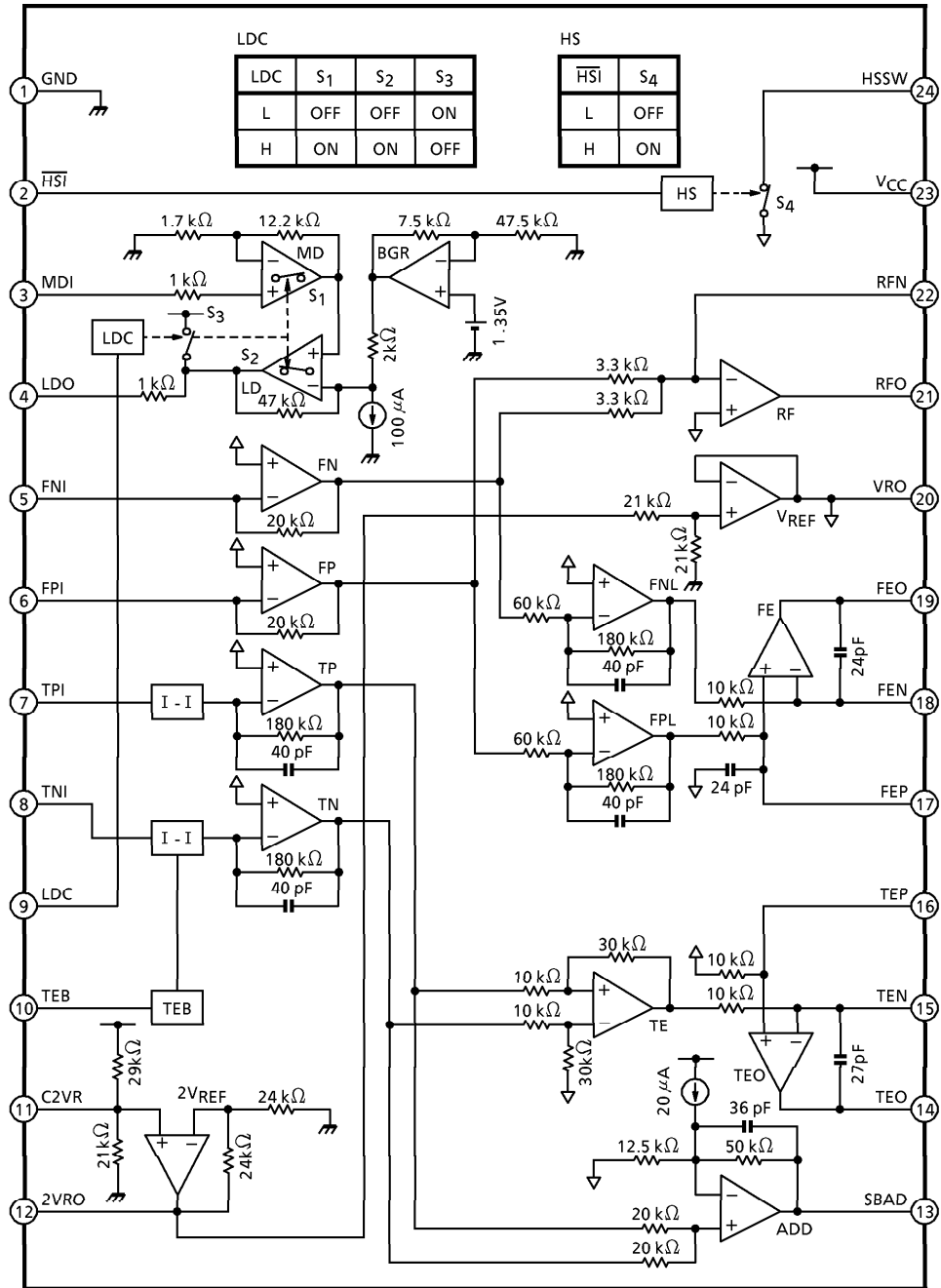

PIN FUNCTION

PIN No.	SYMBOL	I/O	FUNCTIONAL DESCRIPTION	REMARKS
1	GND	—	Ground terminal.	—
2	HSI	I	Analog switch control signal input terminal for hi speed control.	—
3	MDI	I	Monitor photo diode amp input terminal.	Connected to monitor photo diode.
4	LDO	O	Laser diode amp input terminal.	Connected to laser diode circuit.
5	FNI	I	Main beam I-V amp input terminal.	Connected to pin diode B + D.
6	FPI	I	Main beam I-V amp input terminal.	Connected to pin diode A + C.
7	TPI	I	Sub beam I-V amp input terminal.	Connected to pin diode F.
8	TNI	I	Sub beam I-V amp input terminal.	Connected to pin diode E.
9	LDC	I	Laser diode control signal input terminal.	—
10	TEB	I	Tracking balance control signal input terminal.	—
11	C2VR	I	Reference supply input terminal.	—
12	2VRO	O	Reference signal output terminal. ($2V_{REF} = 4.2\text{ V}$ when $V_{CC} = 5\text{ V}$)	—
13	SBAD	O	Sub beam adder signal output terminal.	—
14	TEO	O	Tracking error signal output terminal.	—
15	TEN	I	TE amp negative input terminal.	Connected TEO through feedback register.
16	TEP	I	TE amp positive input terminal.	Connected VRO.
17	FEP	I	FE amp positive input terminal.	Connected VRO through resistor.
18	FEN	I	FE amp negative input terminal.	Connected FEO through feedback register.
19	FEO	O	Focus error signal output terminal.	—
20	VRO	O	Reference signal output terminal. ($V_{REF} = 2.1\text{ V}$ when $V_{CC} = 5\text{ V}$)	—
21	RFO	O	RF signal output terminal.	—
22	RFN	I	RF amp negative input terminal.	Connected RFO through RF amp feedback circuit.
23	VCC	—	Power supply input terminal.	—
24	HSSW	O	Hi speed control signal output terminal.	Connected RF amp feedback circuit.

MAXIMUM RATINGS (Ta = 25°C)

CHARACTERISTIC		SYMBOL	RATING	UNIT
Power Supply Voltage		V _{CC}	- 0.3~12.0	V
Power Dissipation	TA2066F	P _D (*)	400	mW
	TA2066FN		500	
Operating Temperature		T _{opr}	- 35~85	°C
Storage Temperature		T _{stg}	- 55~150	°C

(*) : TA2066F : Derated above 25°C in the proportion 3.2 mW/°C.
 TA2066FN : Derated above 25°C in the proportion 4 mW/°C.

AC CHARACTERISTICS (Unless otherwise specified, V_{CC} = 5 V, Ta = 25°C)

CHARACTERISTIC		SYMBOL	TEST CIR-CUIT	TEST CONDITION	MIN.	TYP.	MAX.	UNIT
Power Supply	Assured Supply Voltage	V _{CC}	—	—	3.5	5.0	5.5	V
	Power Supply Current	I _{CC}	—	SEL = HiZ	—	16.0	22.0	mA
Reference Voltage : 2V _{REF}	Reference Voltage	2VR	—	—	4.0	4.2	4.4	V
	Output Current	I _{OH}	—	ΔV = -0.1 V	5.0	—	—	mA
	Input Current	I _{OL}	—	ΔV = 0.1 V	0.1	—	—	mA
Reference Voltage : V _{REF}	Reference Voltage	VR	—	—	2.0	2.1	2.2	V
	Reference Voltage Limit	ΔVR	—	(2·VR / 2VR) - 1	- 3.0	—	3.0	%
	Output Current	I _{OH}	—	ΔV = -0.1 V	5.0	—	—	mA
	Input Current	I _{OL}	—	ΔV = 0.1 V	5.0	—	—	mA
APC	Gain Voltage	G _V	—	f = 1 kHz	—	200	—	V / V
	Operation Reference Voltage	V _{MDI}	—	V _{LDO} = 3.5V _{DC}	170	178	192	mV
	LD Off Voltage	V _{LDOF}	—	LDC = L, V _{CC} Reference	- 0.7	—	—	V
	Input Bias Current	I _I	—	—	- 200	—	200	nA
RF	Transfer Resistance	R _T	—	f = 100 kHz	120	133	147	kΩ
	Frequency Characteristic	f _c	—	- 3 dB Point	—	3.0	—	MHz
	Output Slew Rate	SR	—	C _{RFO} = 20 pF	—	20	—	V / μs
	Total Harmonic Distortion	THD	—	f = 100 kHz, V _{RF} = 1.4 V _{p-p}	—	- 50	—	dB
	Operation Reference Voltage	V _{OPR}	—	VR Reference	- 1.03	- 0.94	- 0.84	V
	Upper Limit Output Voltage	V _{OH}	—	GND Reference	3.6	—	—	V
	Lower Limit Output Voltage	V _{OL}	—	GND Reference	—	—	0.7	V
	Permissive Load Resistance	R _{LM}	—	—	10	—	—	kΩ
	HSSW ON Voltage (DC)	V _{HSON}	—	VR Reference	—	—	50	mV
	HSSW ON Voltage (AC)	V _{HSON}	—	f = 100 kHz, V _{RFI} = 1.0 V _{p-p}	—	- 50	—	dB

CHARACTERISTIC		SYMBOL	TEST CIR-CUIT	TEST CONDITION	MIN.	TYP.	MAX.	UNIT
FE	Transfer Resistance	R_T	—	$f = 1 \text{ kHz}$	211	234	257	$k\Omega$
	Gain Balance	G_B	—	$f = 1 \text{ kHz}$	-1.0	—	1.0	dB
	Frequency Characteristic	f_c	—	-3 dB Point	—	22	—	kHz
	Total Harmonic Distortion	THD	—	$f = 1 \text{ kHz}$, $V_{FEO} = 2.7 V_{p-p}$	—	-70	—	dB
	Output Offset Voltage	V_{OS}	—	VR Reference	-80	—	80	mV
	Upper Limit Output Voltage	V_{OH}	—	GND Reference	3.8	—	—	V
	Lower Limit Output Voltage	V_{OL}	—	GND Reference	—	—	0.5	V
	Permissive Load Resistance	R_{LM}	—	—	10	—	—	$k\Omega$
TE	Transfer Resistance	R_T	—	$f = 1 \text{ kHz}$	1.60	1.78	1.96	$M\Omega$
	Transfer Resistance Adjusting Range	ΔR_T	—	TEB = 2VR, TEB = VR Reference	-55	-45	-35	%
				TEB = GND, TEB = VR Reference	35	45	55	
	Gain Balance	G_B	—	$f = 1 \text{ kHz}$, TEB = VR	-1.0	—	1.0	dB
	Frequency Characteristic	f_c	—	-3 dB Point	—	22	—	kHz
	Total Harmonic Distortion	THD	—	$f = 1 \text{ kHz}$, $V_{TEO} = 2.7 V_{p-p}$	—	-50	—	dB
	Input Terminal Voltage	V_I	—	VR Reference	—	-150	—	mV
	Output Offset Voltage	V_{OS}	—	VR Reference	-80	—	80	mV
	Upper Limit Output Voltage	V_{OH}	—	GND Reference	3.8	—	—	V
	Lower Limit Output Voltage	V_{OL}	—	GND Reference	—	—	0.5	V
Permissive Load Resistance	R_{LM}	—	—	10	—	—	$k\Omega$	
SBAD	Transfer Resistance	R_T	—	$f = 1 \text{ kHz}$	324	450	594	$k\Omega$
	Frequency Characteristic	f_c	—	—	—	22	—	kHz
	Total Harmonic Distortion	THD	—	$f = 1 \text{ kHz}$, $V_{SBAD} = 2.0 V_{p-p}$	—	-50	—	dB
	Operation Reference Voltage	V_{OPR}	—	VR Reference	-1.1	-1.0	-0.9	V
	Upper Limit Output Voltage	V_{OH}	—	GND Reference	3.8	—	—	V
	Lower Limit Output Voltage	V_{OL}	—	GND Reference	—	—	0.5	V
	Permissive Load Resistance	R_{LM}	—	—	10	—	—	$k\Omega$

APPLICATION CIRCUIT

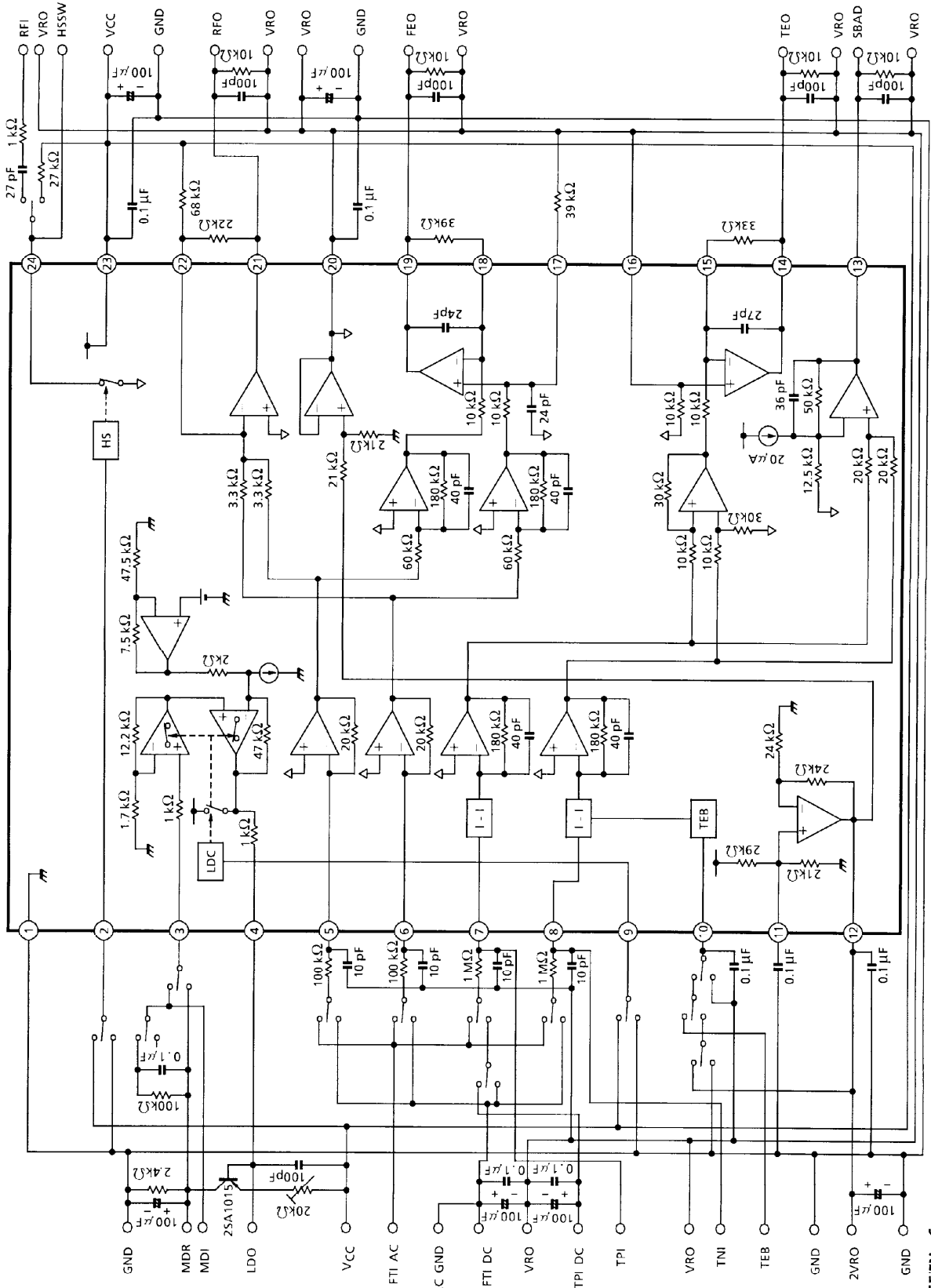

TA2066F/FN-6

PACKAGE DIMENSIONS
SSOP24-P-300-1.00

Unit : mm

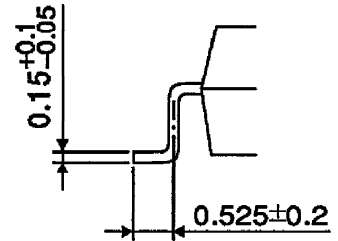
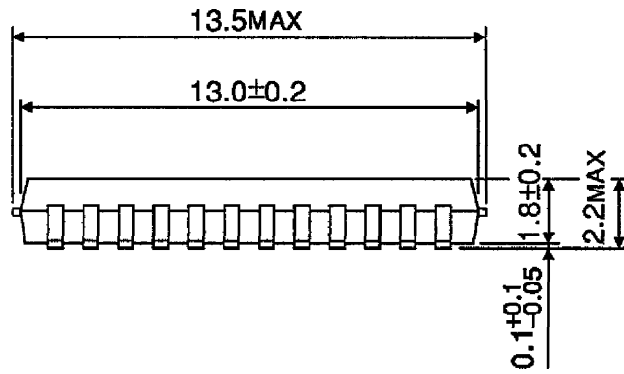
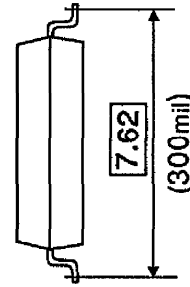
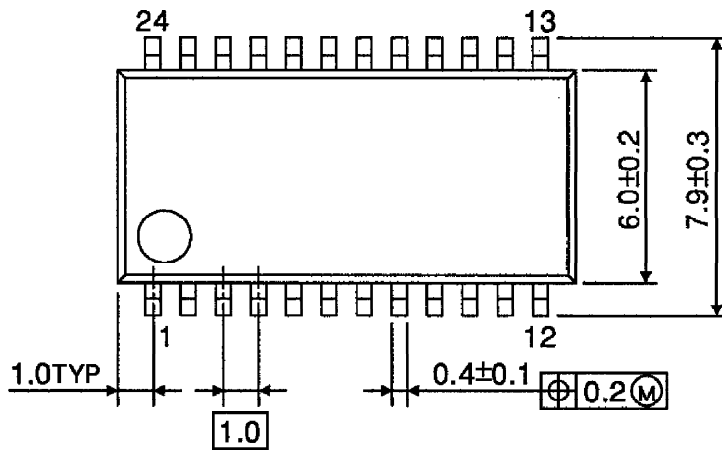

Weight : 0.3 g (Typ.)

PACKAGE DIMENSIONS
SSOP24-P-300-0.65A

Unit : mm

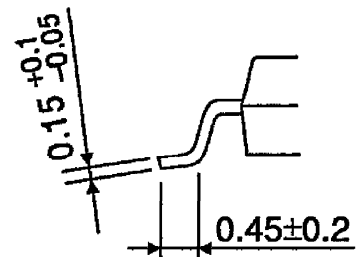
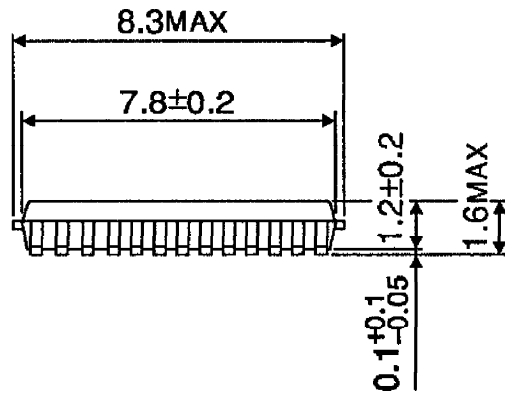
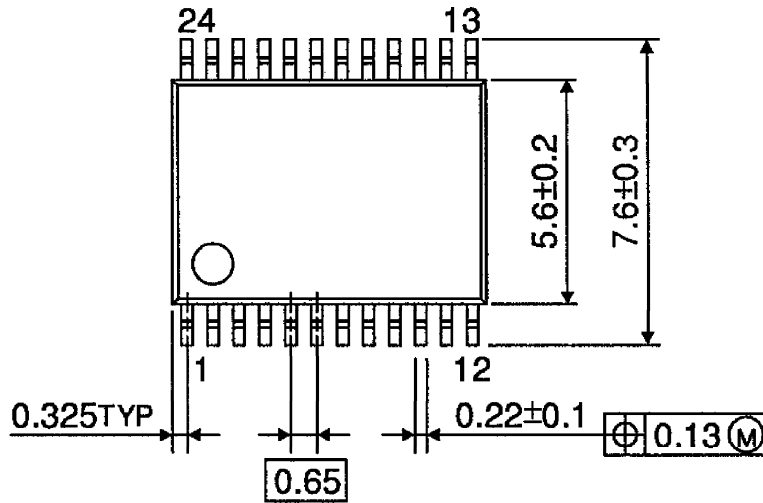

Weight : 0.17 g (Typ.)