

TOSHIBA

TC90A46F

TENTATIVE TOSHIBA CMOS DIGITAL INTEGRATED CIRCUIT SILICON MONOLITHIC

TC90A46F

PAL NOISE REDUCTION IC

TC90A46F is a noise reduction IC for PAL.

Used together with TC90A36F (field double-speed conversion), the device realizes a noise reduction (NR) function.

As input data, the Y and C signals processed by TC90A36F are used.

The input Y and C signals are digitally processed and their noise is reduced (YNR, CNR).

As memory, general-purpose memory (4M bit EDO) is used.

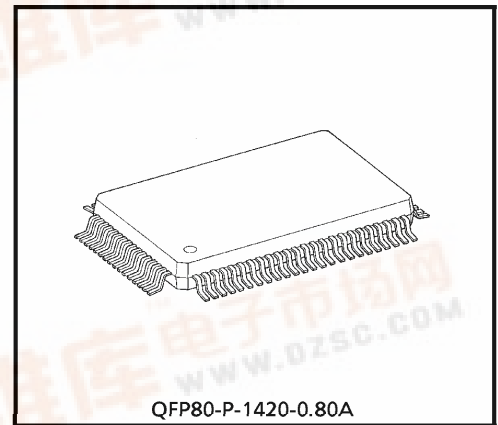

QFP80-P-1420-0.80A

Weight : 1.6 g (Typ.)

FEATURES

- Realizes PAL noise reduction in combination with TC90A36F.
- Noise reduce processing between Y and C frames using 4M bit memory.
- Motion detector circuit built in.
- EDO memory controller built in.
- Variable NR level
- Y/C digital interface
- Interface with microcontroller using I²C bus
- 5 V single power supply

980910FBA1

- TOSHIBA is continually working to improve the quality and the reliability of its products. Nevertheless, semiconductor devices in general can malfunction or fail due to their inherent electrical sensitivity and vulnerability to physical stress. It is the responsibility of the buyer, when utilizing TOSHIBA products, to observe standards of safety, and to avoid situations in which a malfunction or failure of a TOSHIBA product could cause loss of human life, bodily injury or damage to property. In developing your designs, please ensure that TOSHIBA products are used within specified operating ranges as set forth in the most recent products specifications. Also, please keep in mind the precautions and conditions set forth in the TOSHIBA Semiconductor Reliability Handbook.
- The products described in this document are subject to the foreign exchange and foreign trade laws.
- The information contained herein is presented only as a guide for the applications of our products. No responsibility is assumed by TOSHIBA CORPORATION for any infringements of intellectual property or other rights of the third parties which may result from its use. No license is granted by implication or otherwise under any intellectual property or other rights of TOSHIBA CORPORATION or others.
- The information contained herein is subject to change without notice.

BLOCK DIAGRAM

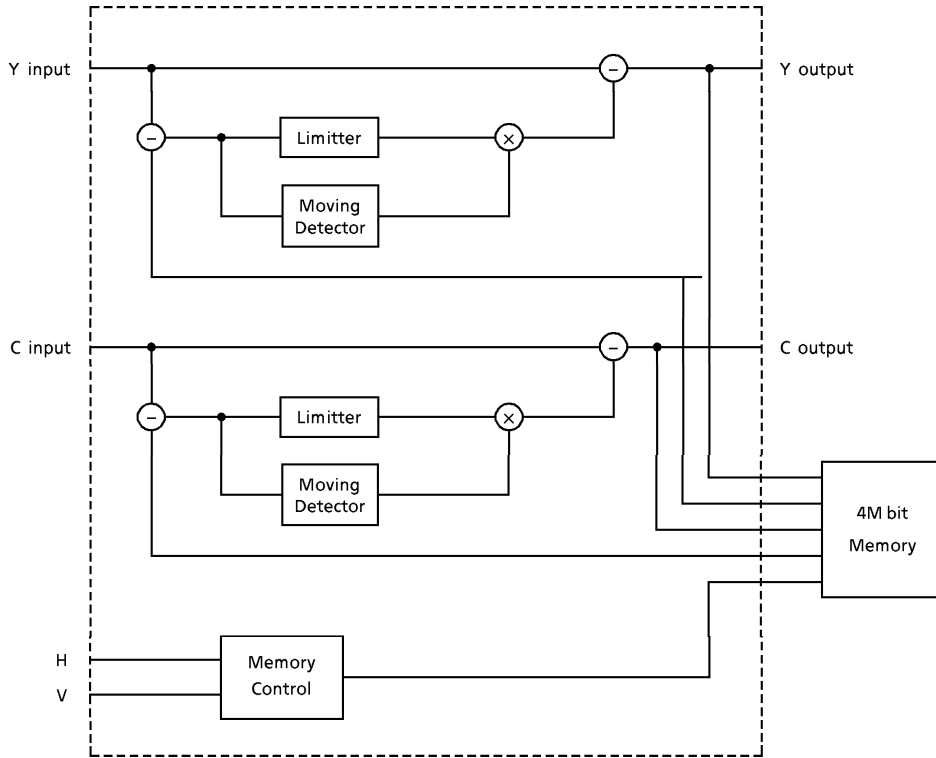

PIN CONNECTION

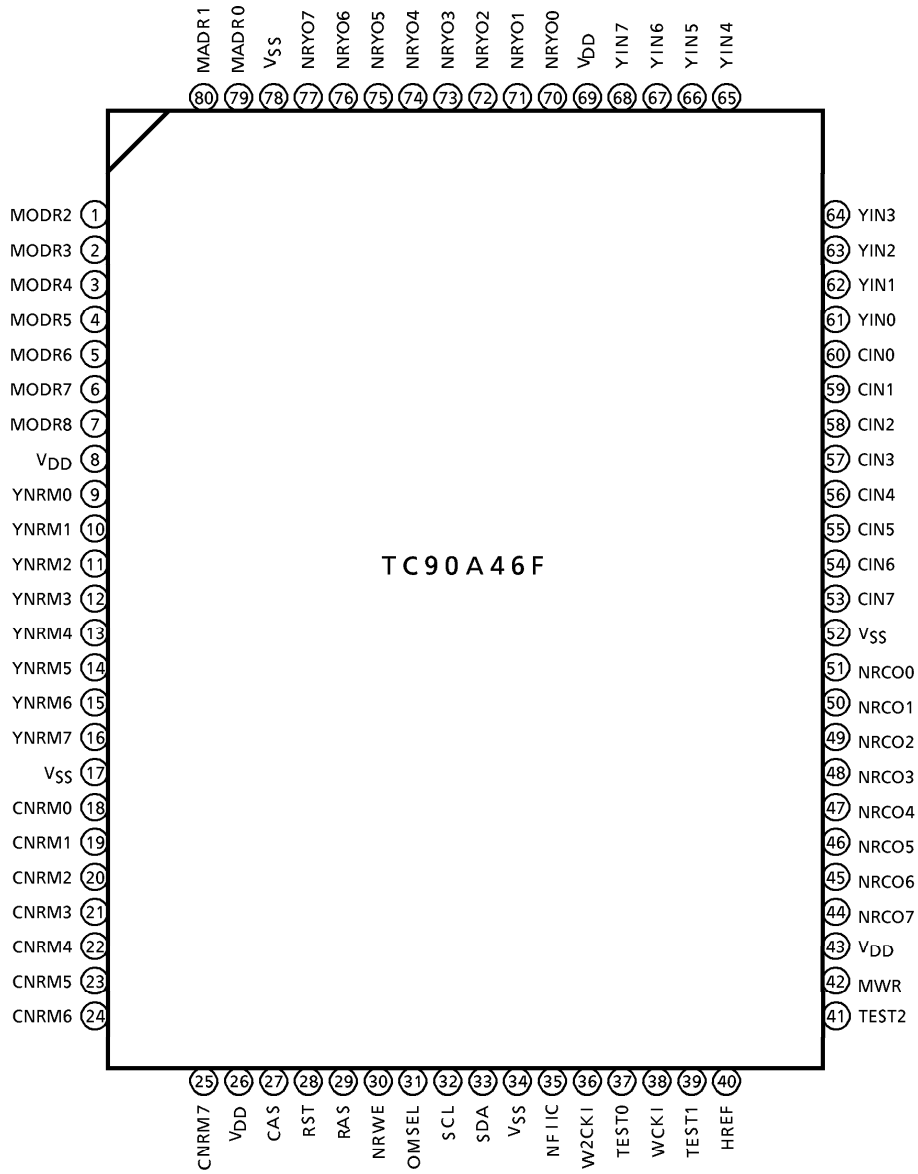

PIN FUNCTION

Pin List (80 pin FP)

PIN No.	PIN NAME	I/O	FUNCTION
1	MADR2	O	Memory address output
2	MADR3	O	Memory address output
3	MADR4	O	Memory address output
4	MADR5	O	Memory address output
5	MADR6	O	Memory address output
6	MADR7	O	Memory address output
7	MADR8	O	Memory address output (MSB)
8	V _{DD}		Digital V _{DD} ($\pm 5\%$)
9	YNRM0	I/O	Y signal memory input/output (LSB)
10	YNRM1	I/O	Y signal memory input/output
11	YNRM2	I/O	Y signal memory input/output
12	YNRM3	I/O	Y signal memory input/output
13	YNRM4	I/O	Y signal memory input/output
14	YNRM5	I/O	Y signal memory input/output
15	YNRM6	I/O	Y signal memory input/output
16	YNRM7	I/O	Y signal memory input/output (MSB)
17	V _{SS}		Digital V _{SS}
18	CNRM0	I/O	C signal memory input/output (LSB)
19	CNRM1	I/O	C signal memory input/output
20	CNRM2	I/O	C signal memory input/output
21	CNRM3	I/O	C signal memory input/output
22	CNRM4	I/O	C signal memory input/output
23	CNRM5	I/O	C signal memory input/output
24	CNRM6	I/O	C signal memory input/output
25	CNRM7	I/O	C signal memory input/output (MSB)
26	V _{DD}		Digital V _{DD} ($\pm 5\%$)
27	CAS	O	CAS signal
28	RST	I	System reset signal
29	RAS	O	RAS signal
30	NRWE	O	Memory write enable
31	OMSEL	I	Test pin
32	SCL	I	I ² C bus clock input
33	SDA	I/O	I ² C bus data input/output
34	V _{SS}		Digital V _{SS}
35	NFIIC	I	I ² C bus noise filter switch
36	W2CKI	I	Double clock input
37	TEST0	I	Test pin
38	WCKI	I	Clock input
39	TEST1	I	Test pin
40	HREF	I	Horizontal reference input

PIN No.	NAME	I/O	FUNCTION
41	TEST2	I	Test pin
42	MWR	I	Frame reset signal input
43	V _{DD}		Digital V _{DD} (± 5%)
44	NRCO7	O	C signal output (MSB)
45	NRCO6	O	C signal output
46	NRCO5	O	C signal output
47	NRCO4	O	C signal output
48	NRCO3	O	C signal output
49	NRCO2	O	C signal output
50	NRCO1	O	C signal output
51	NRCO0	O	C signal output (LSB)
52	V _{SS}		Digital V _{SS}
53	CIN7	I	C signal input (MSB)
54	CIN6	I	C signal input
55	CIN5	I	C signal input
56	CIN4	I	C signal input
57	CIN3	I	C signal input
58	CIN2	I	C signal input
59	CIN1	I	C signal input
60	CIN0	I	C signal input (LSB)
61	YIN7	I	Y signal input (MSB)
62	YIN6	I	Y signal input
63	YIN5	I	Y signal input
64	YIN4	I	Y signal input
65	YIN3	I	Y signal input
66	YIN2	I	Y signal input
67	YIN1	I	Y signal input
68	YIN0	I	Y signal input (LSB)
69	V _{DD}		Digital V _{DD} (± 5%)
70	NRYO7	O	Y signal output (MSB)
71	NRYO6	O	Y signal output
72	NRYO5	O	Y signal output
73	NRYO4	O	Y signal output
74	NRYO3	O	Y signal output
75	NRYO2	O	Y signal output
76	NRYO1	O	Y signal output
77	NRYO0	O	Y signal output (LSB)
78	V _{SS}		Digital V _{SS}
79	MADR0	O	Memory address output (LSB)
80	MADR1	O	Memory address output

NR SYSTEM

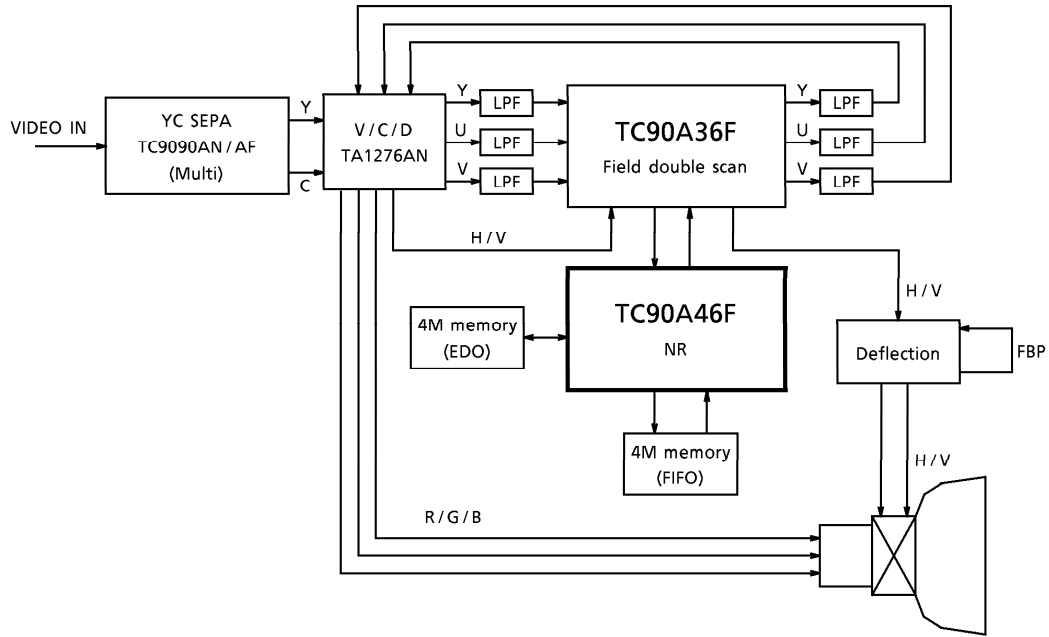

I²C BUS REGISTERS

SUB ADDRESS	15	14	13	12	11	10	9	8	7
40HEX	ONMVF	YSTD	YSTD	MYST	MYLV3	MYLV2	MYLV1	MYLV0	

6	5	4	3	2	1	0
		MYCO4	MYCO3	MYCO2	MYCO1	MYCO0

- ONMVF (1) Y motion detect horizontal filter 0 : off 1 : on
- YSTDP (1) Y PAL detection (1 : on)
- YSTDN (1) Y NTSC detection (1 : on)
- MYSTD (1) Y forced standard mode (1 : on)
- MYLV (4) Y NR level
- MYCOR (5) Y motion detect sensitivity Offset

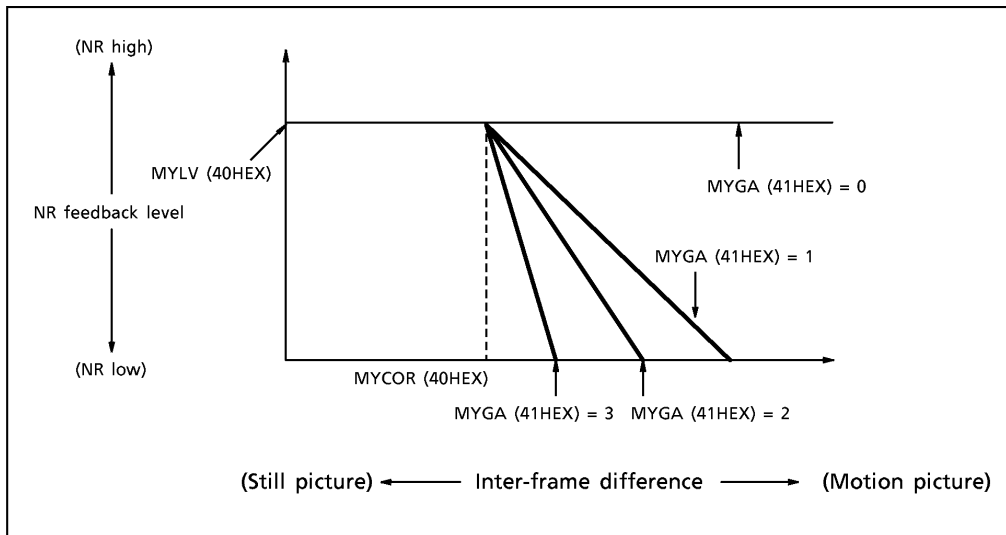

SUB ADDRESS	15	14	13	12	11	10	9	8	7
41HEX	YEGL3	YEGL2	YEGL1	YEGL0	YEDON		MYGA1	MYGA0	FBL

6	5	4	3	2	1	0
YLTL6	YLTL5	YLTL4	YLTL3	YLTL2	YLTL1	YLTL0

- YEGL Y motion detect horizontal edge detect level
- YEGON Y motion detect horizontal edge detect control on/off (1 : on)
- MYGA Y motion detect sensitivity Gradient
- FBNLC Y motion detect non-linear control (normally set to 0)
- YLTL Y feedback limit value

SUB ADDRESS	15	14	13	12	11	10	9	8	7
42HEX		CSTD	CSTDN	MCSTD	MCLV3	MCLV2	MCLV1	MCLV0	

6	5	4	3	2	1	0
		MCCO4	MCCO3	MCCO2	MCCO1	MCCO0

CSTD C PAL detection (1 : on)
 CSTDN C NTSC detection (1 : on)
 MCSTD C forced standard mode (1 : on)
 MCLV C NR level
 MCCOR C motion detect sensitivity Offset

SUB ADDRESS	15	14	13	12	11	10	9	8	7
43HEX							MCGA1	MCGA0	

6	5	4	3	2	1	0
CLTL6	CLTL5	CLTL4	CLTL3	CLTL2	CLTL1	CLTL0

MCGA C motion detect sensitivity Gradient
 CLTL C feedback limit value

SUB ADDRESS	15	14	13	12	11	10	9	8	7
44HEX	NVWS8	NVWS7	NVWS6	NVWS5	NVWS4	NVWS3	NVWS2	NVWS1	NVWS0

6	5	4	3	2	1	0
NHWS6	NHWS5	NHWS4	NHWS3	NHWS2	NHWS1	NHWS0

NVWST NR vertical start phase
 NHWST NR horizontal start phase

SUB ADDRESS	15	14	13	12	11	10	9	8	7
45HEX	NVWE8	NVWE7	NVWE6	NVWE5	NVWE4	NVWE3	NVWE1	NVWE2	NVWE0

6	5	4	3	2	1	0
NHWE6	NHWE5	NHWE4	NHWE3	NHWE2	NHWE1	NHWE0

NVWST NR vertical end phase
 NVWST NR horizontal end phase

SUB ADDRESS	15	14	13	12	11	10	9	8	7
46HEX	YCLT3	YCLT2	YCLT1	YCLT0			YNGA1	YNGA0	

6	5	4	3	2	1	0
		YNCO	YNCL3	YNCL2	YNCL1	YNCL0

YCLT Motion-linked Y coring level limit
 YNGA Motion-linked Y coring gain
 YNCON Motion-linked Y coring on/off (1 : on)
 YNCL Motion-linked Y coring offset (must match MYLV)

APPLICATION CIRCUIT

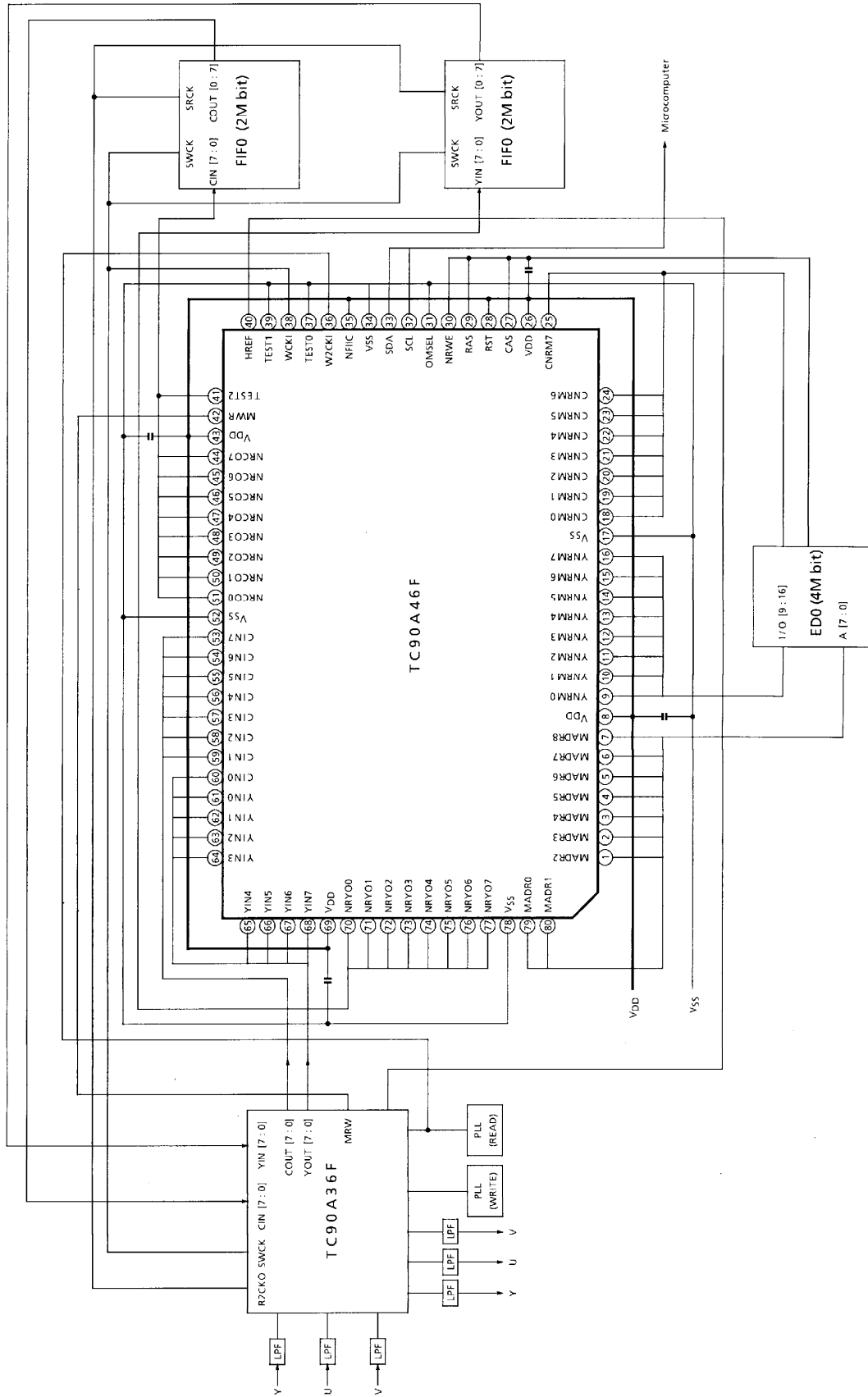

PACKAGE DIMENSIONS
QFP80-P-1420-0.80A

Unit : mm

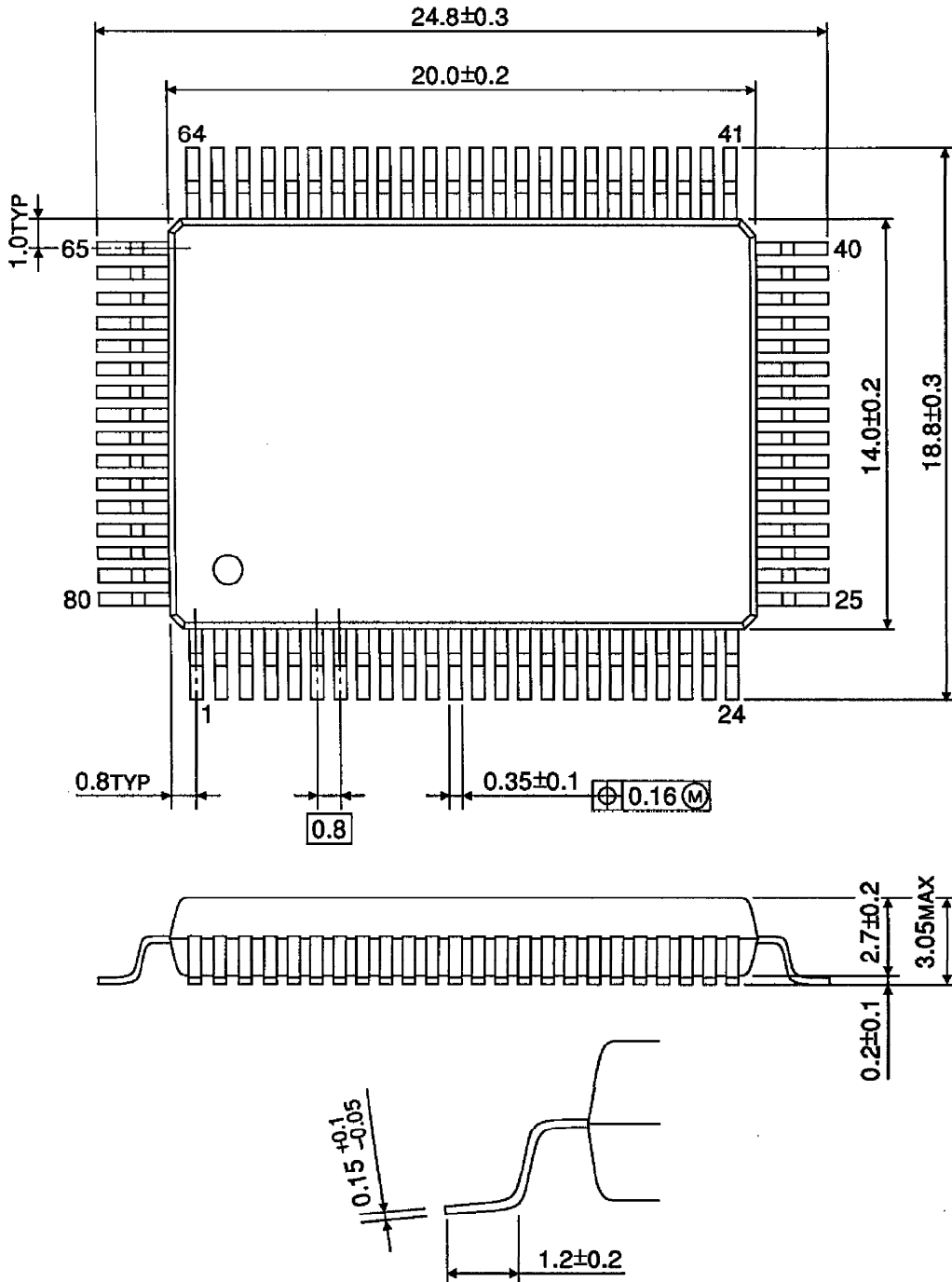

Weight : 1.6g (Typ.)