

TOSHIBA

MIG30J106L

TOSHIBA INTELLIGENT POWER MODULE

MIG30J106L

HIGH POWER SWITCHING APPLICATIONS

MOTOR CONTROL APPLICATIONS

The Electrodes are Isolated from Case

- Three Phase IGBT Inverter Output
- Gate Drive Circuit
- Protection Logic
 - Over Current
 - Over Temperature
 - Under Voltage

EQUIVALENT CIRCUIT

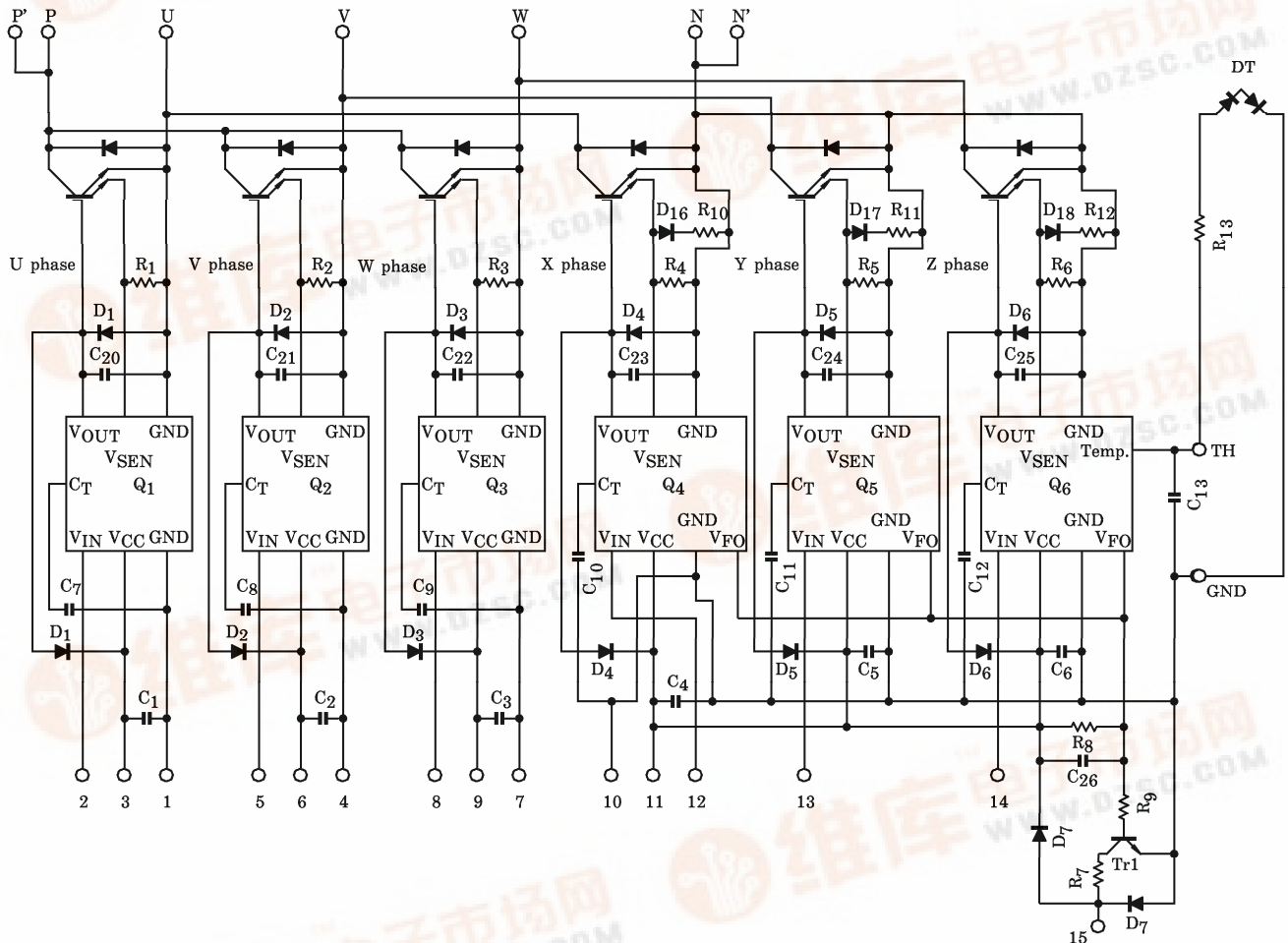

961001EAA2

- TOSHIBA is continually working to improve the quality and the reliability of its products. Nevertheless, semiconductor devices in general can malfunction or fail due to their inherent electrical sensitivity and vulnerability to physical stress. It is the responsibility of the buyer, when utilizing TOSHIBA products, to observe standards of safety, and to avoid situations in which a malfunction or failure of a TOSHIBA product could cause loss of human life, bodily injury or damage to property. In developing your designs, please ensure that TOSHIBA products are used within specified operating ranges as set forth in the most recent products specifications. Also, please keep in mind the precautions and conditions set forth in the TOSHIBA Semiconductor Reliability Handbook.
- The information contained herein is presented only as a guide for the applications of our products. No responsibility is assumed by TOSHIBA CORPORATION for any infringements of intellectual property or other rights of the third parties which may result from its use. No license is granted by implication or otherwise under any intellectual property or other rights of TOSHIBA CORPORATION or others.
- The information contained herein is subject to change without notice.

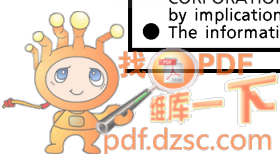

MAXIMUM RATINGS ($T_j = 25^\circ\text{C}$)

	ITEM	SYMBOL	CONDITION	RATING	UNIT
Inverter Part	Supply Voltage	V_{CC}	P-N	450	V
	Collector Emitter Voltage	V_{CES}	—	600	V
	Collector Current (DC)	$\pm I_C$	$T_c = 25^\circ\text{C}$	30	A
	Collector Current (Peak)	$\pm I_{CP}$	$T_c = 25^\circ\text{C}$	60	A
	Collector Power Dissipation	P_C	$T_c = 25^\circ\text{C}$	50	W
	Junction Temperature	T_j	—	150	$^\circ\text{C}$
Control Part	Supply Voltage	V_D	—	20	V
	Input Current	I_{IN}	—	30	mA
	Fault Output Voltage	V_{FO}	—	20	V
	Fault Output Current	I_{FO}	—	10	mA
All System	Operating Temperature	T_c	—	-20~+90	$^\circ\text{C}$
	Storage Temperature Range	T_{stg}	—	-40~+125	$^\circ\text{C}$
	Isolation Voltage	V_{ISO}	(*)	2500	V_{rms}

(*) AC 1 minute, Defect Current 1mA.

ELECTRICAL CHARACTERISTICS ($T_j = 25^\circ\text{C}$)

Inverter part

ITEM	SYMBOL	TEST CIR-CUIT	TEST CONDITION	MIN.	TYP.	MAX.	UNIT
Supply Voltage	V_{CC}	—	P-N	—	300	—	V
Collector-Emitter Saturation Voltage	$V_{CE(sat)}$	Fig.1	$V_D = 15\text{V}$ $I_{IN} = 10\text{mA}$ $I_C = 30\text{A}$	—	1.8	2.3	V
			$I_C = 30\text{A}, T_j = 125^\circ\text{C}$	—	—	3.0	
Forward Voltage	V_F	Fig.2	$I_F = 30\text{A}$	—	2.2	2.9	V
Switching Time	t_{on}	Fig.3	$V_{CC} = 300\text{V}$ $I_C = 30\text{A}$ $V_D = 15\text{V}$ $I_{IN} = 10\text{mA}$ L-Load	—	1.3	2.5	μs
	t_{rr}			—	0.1	0.2	
	$t_c(\text{on})$			—	0.8	1.6	
	t_{off}			—	1.3	2.8	
	$t_c(\text{off})$			—	0.7	1.0	
Collector Cut-off Current	I_{CEX}	Fig.5	$V_{CE} = 600\text{V}$ $T_j = 125^\circ\text{C}$	—	—	1.0 20	mA

CONTROL PART ($T_j = 25^\circ\text{C}$)

ITEM		SYMBOL	TEST CIR-CUIT	TEST CONDITION	MIN.	TYP.	MAX.	UNIT
Circuit Current		I_D	—	$V_D = 15\text{V}$ High Side	—	7	—	mA
				$I_{IN} = 10\text{mA}$ Low Side	—	21	—	
Input On Current		$I_{IN}(\text{ON})$	—	$V_D = 15\text{V}$	—	5.0	—	mA
Input Off Current		$I_{IN}(\text{OFF})$			—	4.0	—	
Fault Output Current (Normal Operation)		I_{FO}	—	$V_D = 15\text{V}, V_{FO} = 15\text{V}$	—	10	—	mA
Over Current Trip Level		OC	Fig.6	$V_D = 15\text{V}$ (Low Side)	28.5	36	—	A
				$V_D = 15\text{V}$ (High Side)	48	56	—	
Over Current Cut Off Time		$t_{\text{off}}(\text{OC})$	—	$V_D = 15\text{V}$	—	13	—	μs
Over Temperature Protection	Trip Level	OT	—	—	100	110	—	$^\circ\text{C}$
	Reset Level				—	15	—	
Under Voltage Protection	Trip Level	UV	—	—	—	12.0	—	V
	Reset Level				UVr	—	12.5	
Fault Output Pulse Width		t_{FO}	—	$V_D = 15\text{V}$	8	13	—	ms

THERMAL RESISTANCE

ITEM		SYMBOL	TEST CIR-CUIT	TEST CONDITION	MIN.	TYP.	MAX.	UNIT
Junction to Case Thermal Resistance		$R_{\text{th}(j-c)}$	—	INV, IGBT	—	1.8	2.5	$^\circ\text{C}/\text{W}$
		$R_{\text{th}(j-c)}$	—	INV, FWD	—	3.2	4.5	
Capacitance (Electrodes-Case)			—	—	—	450	900	pF

TEST CIRCUIT

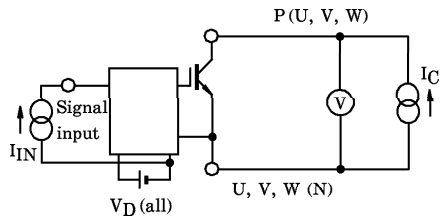

Fig.1 $V_{CE(sat)}$

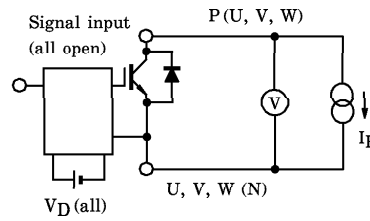

Fig.2 V_F

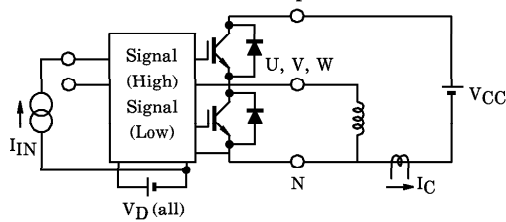
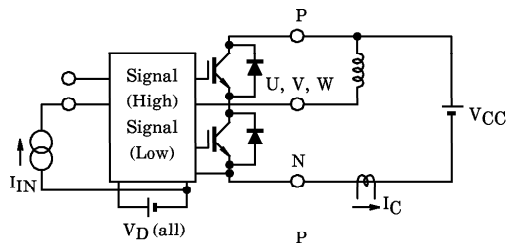

Fig.3 Switching Time Test

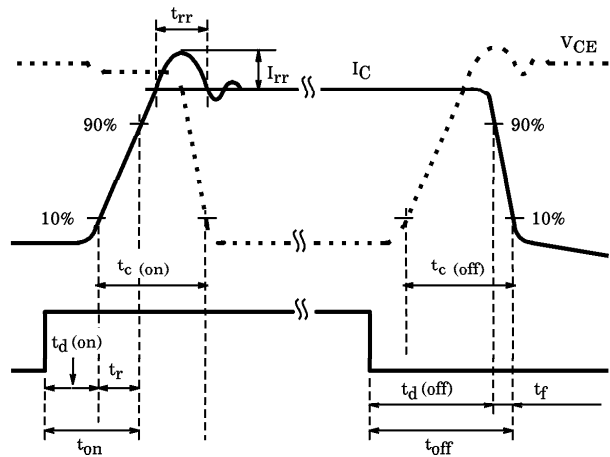

Fig.4 Switching Test Waveforms

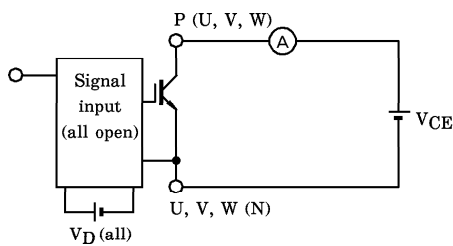

Fig.5 I_{CEX}

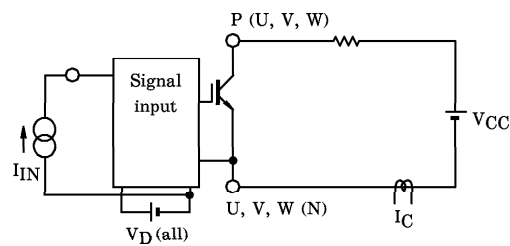
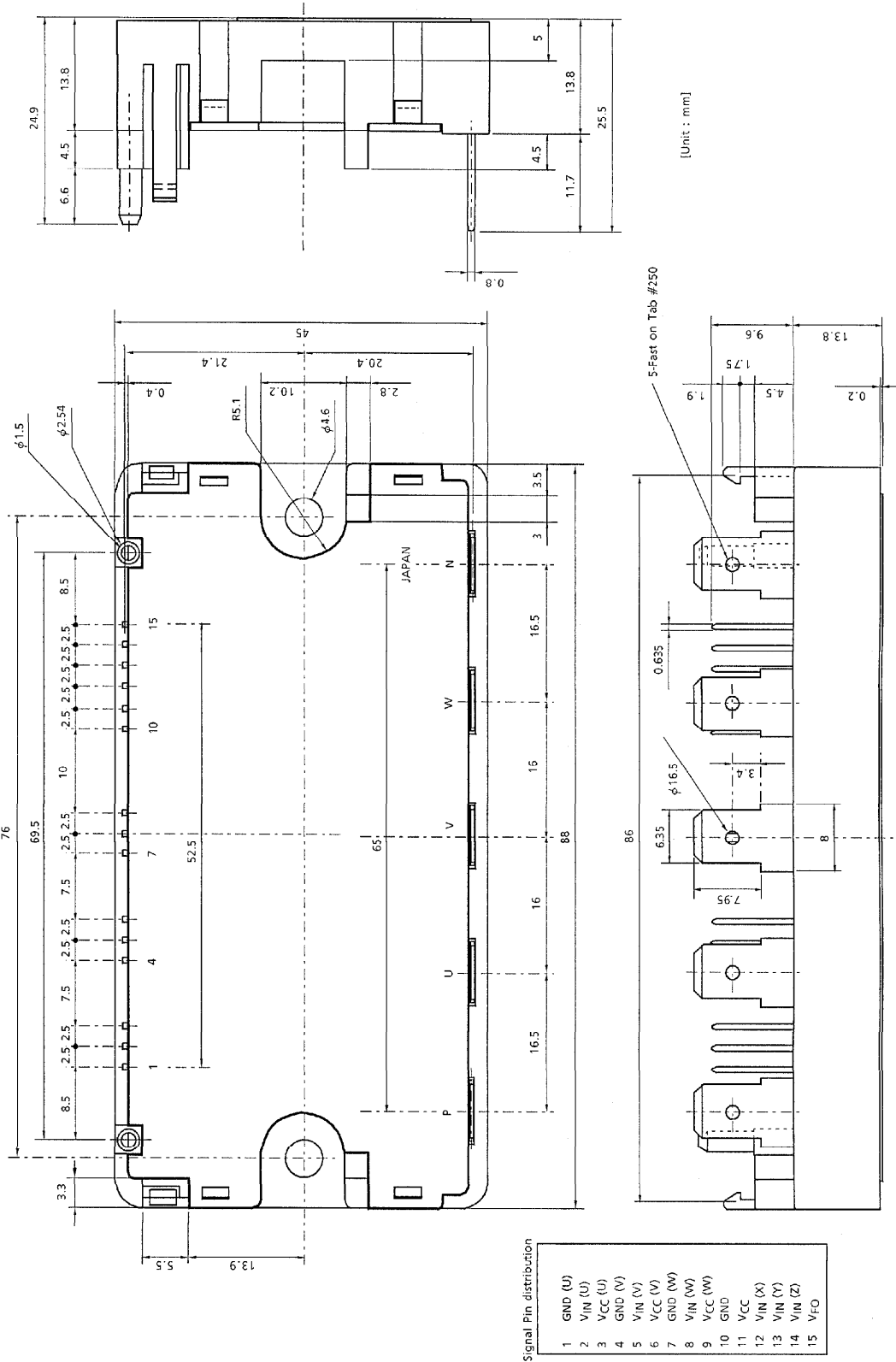

Fig.6 OC

OUTLINE



[Unit : mm]

TIMING CHART FOR SHORT CURRENT PROTECTION SEQUENCE

1. Upon occasion of short current condition, at first step, V_{GE} is step-down to one-half of nominal value in order to reduce IGBT saturation current and finally, V_{GE} is completely interrupted after some certain time, $t_{off}(OC)$.
2. An error signal output (V_{FO}) goes into 'H' level when the lower arm IGBT is subjected to over current condition. The timing of V_{FO} output ('H' level) is provided at complete interruption of V_{GE} and the 'H' level is maintained during some certain time duration (t_{FO}).
3. The reset operation is provided on condition that error signal output return to 'L' level after certain time duration and over current or short current condition is removed, and next input signal turns from operation "off" to "on".

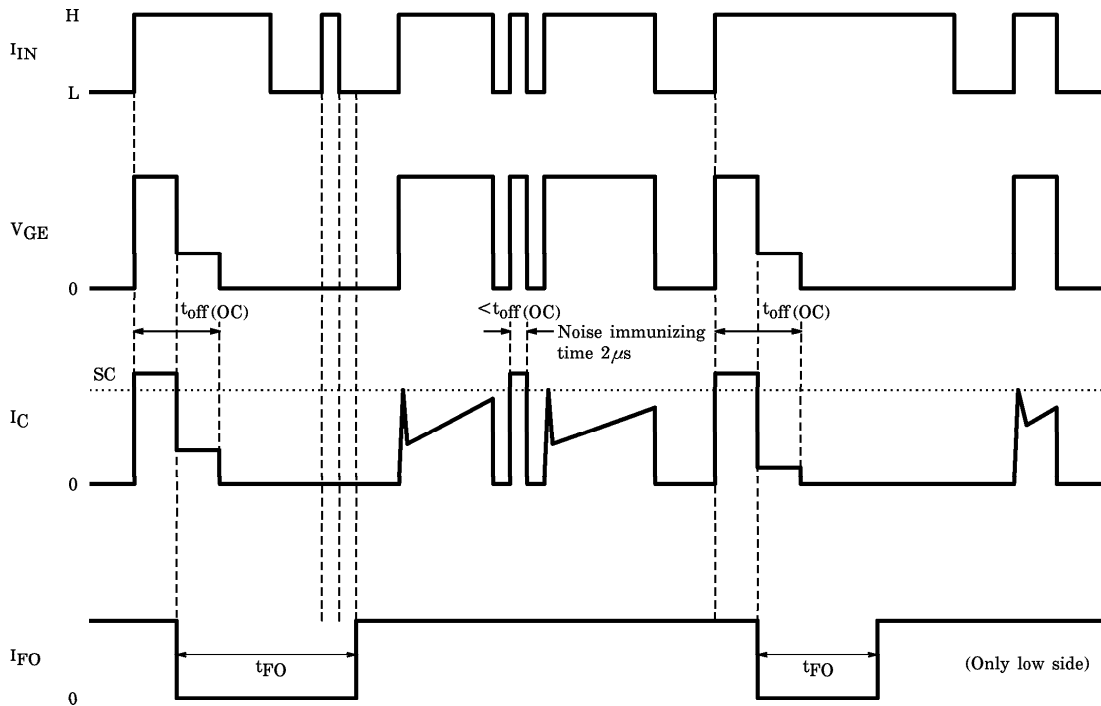

TIMING CHART FOR OVER CURRENT PROTECTION SEQUENCE

1. Upon occasion of over current condition, at first step, V_{GE} is step-down to one-half of nominal value in order to reduce IGBT saturation current and finally, V_{GE} is completely interrupted after some certain time, $t_{off}(OC)$.
2. An error signal output (V_{FO}) goes into 'H' level when the lower arm IGBT is subjected to over current condition. The timing of V_{FO} output ('H' level) is provided at complete interruption of V_{GE} and the 'H' level is maintained during some certain time duration (t_{FO}).
3. The reset operation is provided on condition that error signal output return to 'L' level after certain time duration and over current condition is removed and input signal turns from operation "off" to "on".

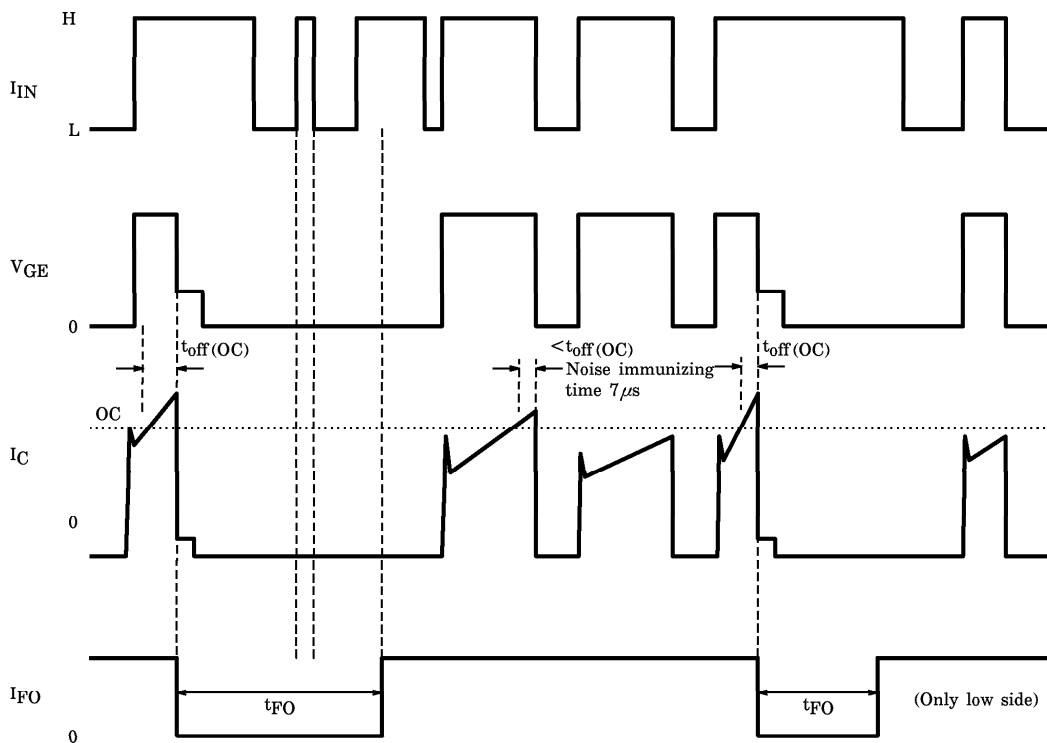

TIMING CHART FOR CONTROL POWER SUPPLY UNDER VOLTAGE PROTECTION SEQUENCE

1. Upon occasion of control power supply under voltage, gate voltage (V_{GE}) is interrupted and IGBT moves into 'off-stage'.
(This condition continues between UV Trip Level and UV Reset Level as shown in the chart)
2. An error signal output (V_{FO}) stays in 'H' level until the power supply voltage returns to the reset level after the voltage reaches to the trip level.
3. The reset operation is provided on condition that power supply voltage returns to the UV reset level and input signal turns from operation "off" to "on".

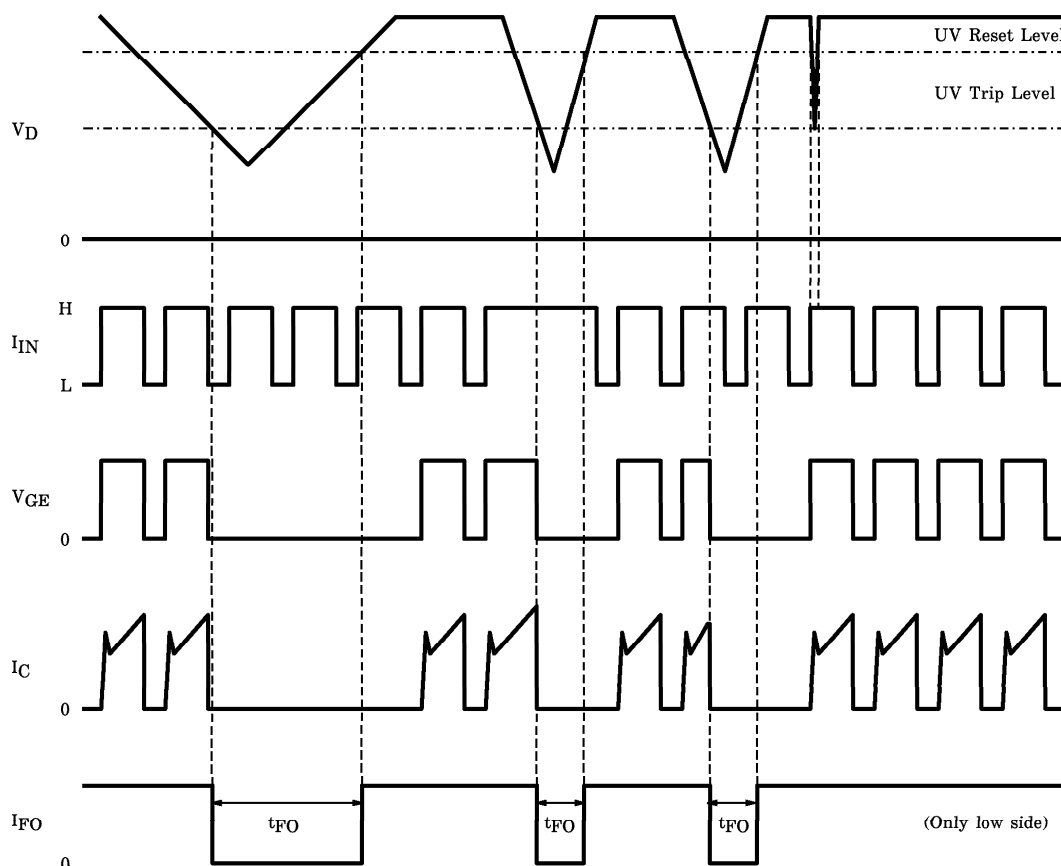

TIMING CHART FOR OVER TEMPERATURE PROTECTION SEQUENCE

1. Using temperature dependent characteristics of diode on IMS substrate, the case temperature (T_c) is detected. Upon occasion of over temperature condition, V_{GE} of the lower arm IGBT is interrupted. (This condition continues between OT Trip Level and OT Reset Level as shown in the chart)
2. An error signal output (V_{FO}) stays in 'H' level until the case temperature goes below the reset level after the temperature reaches to the trip level.
3. The reset operation is provided on condition that case temperature goes below the OT reset level and input signal turns from operation "off" to "on".

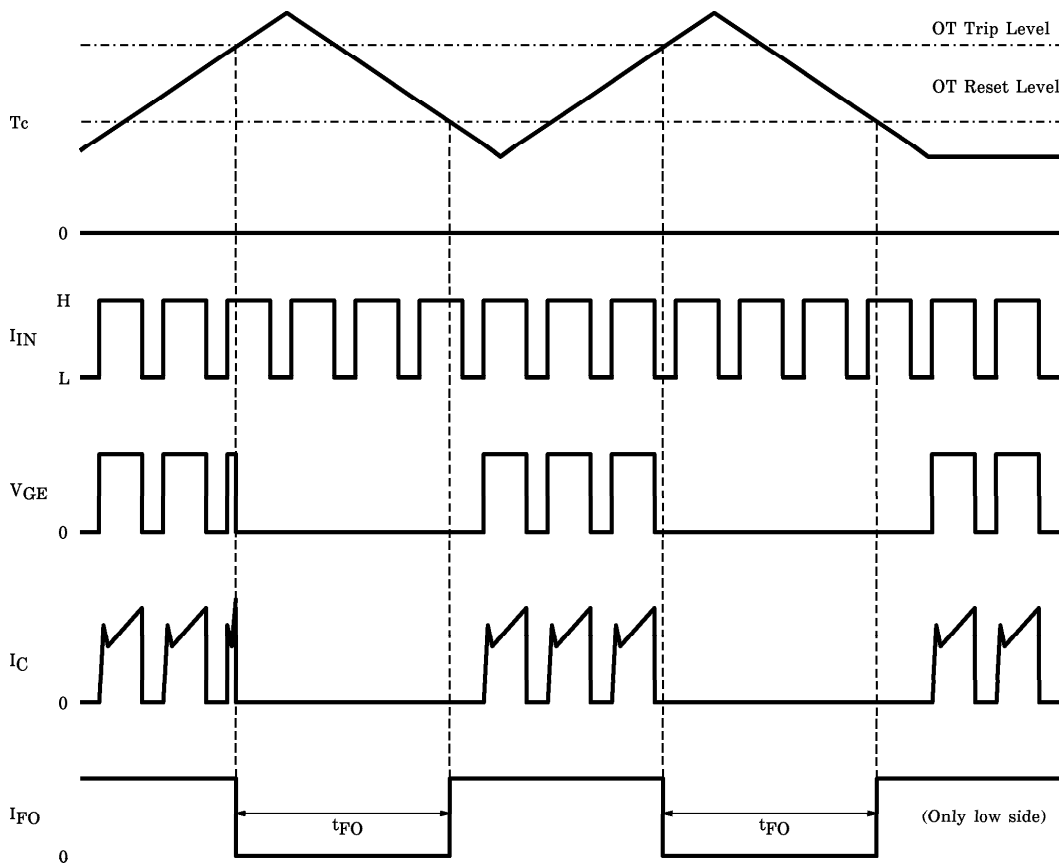

APPLICATION

