



CY7C276

16K x 16 Reprogrammable PROM

Features

- 0.8-micron CMOS for optimum speed/power
- High speed (for commercial and military) — 25-ns access time
- 16-bit-wide words
- Three programmable chip selects
- Programmable output enable
- 44-pin PLCC and 44-pin LCC packages
- 100% reprogrammable in windowed packages
- TTL-compatible I/O
- Capable of withstanding greater than 2001V static discharge

Functional Description

The CY7C276 is a high-performance 16K-word by 16-bit CMOS PROM. It is available in a 44-pin PLCC/CLCC and a 44-pin LCC packages, and is 100% reprogrammable in windowed packages. The memory cells utilize proven EPROM floating gate technology and word-wide programming algorithms.

The CY7C276 allows the user to independently program the polarity of each chip select (CS_2 – CS_0). This provides on-chip decoding of up to eight banks of PROM. The polarity of the asynchronous output enable pin (OE) is also programmable.

In order to read the CY7C276, all three chip selects must be active and OE must be asserted. The contents of the memory location addressed by the address lines (A_{13} – A_0) will become available on the output lines (D_{15} – D_0). The data will remain on the outputs until the address changes or the outputs are disabled.

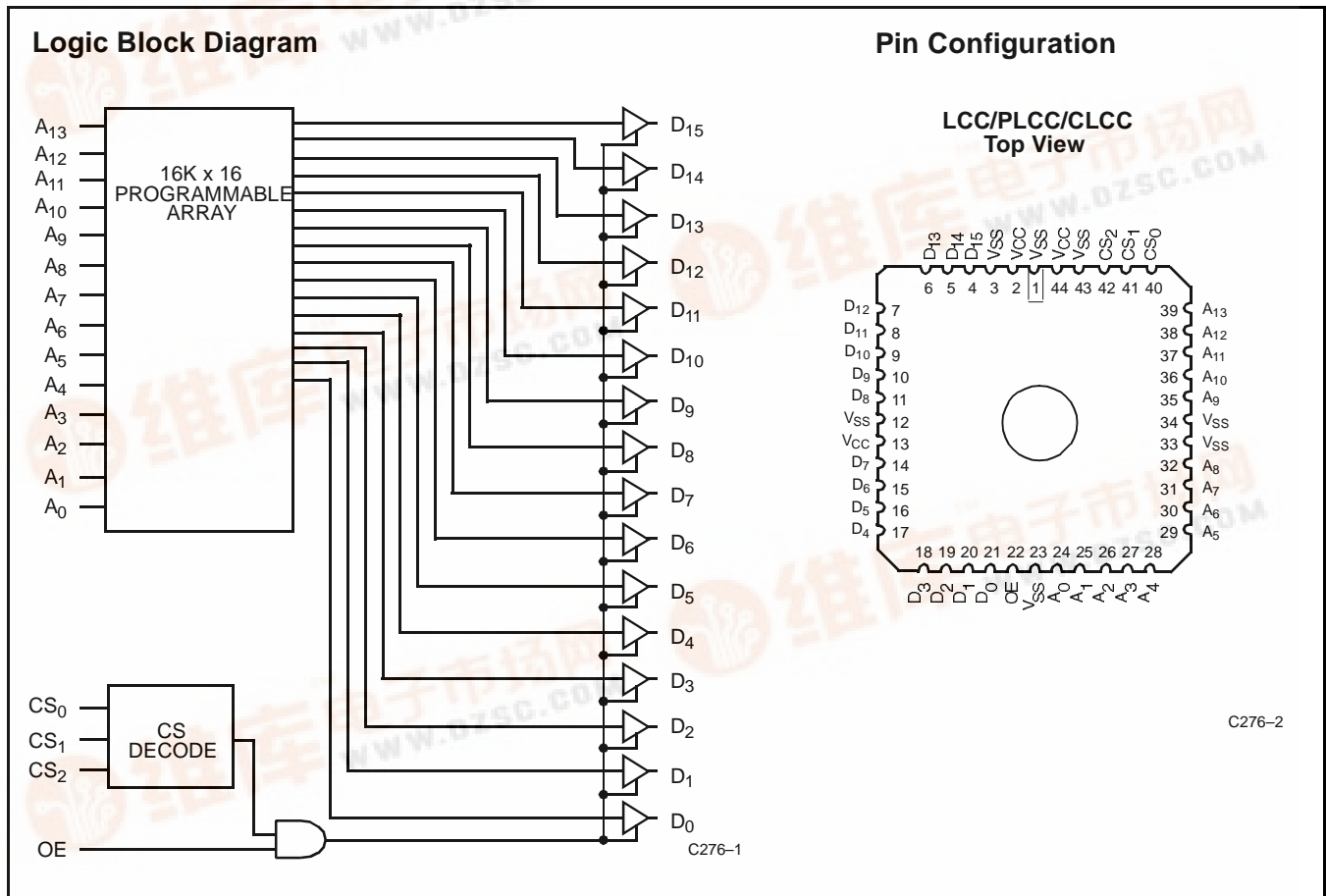



Selection Guide

		CY7C276-25	CY7C276-30	CY7C276-35
Maximum Access Time (ns)		25	30	35
Maximum Operating Current (mA)	Commercial	175	175	175
	Military	200	200	200

Maximum Ratings

(Above which the useful life may be impaired. For user guidelines, not tested.)

- Storage Temperature -65°C to +150°C
- Ambient Temperature with Power Applied..... -55°C to +125°C
- Supply Voltage to Ground Potential -0.5V to +7.0V
- DC Voltage Applied to Outputs in High Z State -0.5V to +7.0V
- DC Input Voltage..... -3.0V to +7.0V
- DC Program Voltage 13.0V
- UV Erasure 7258 Wsec/cm²

- Static Discharge Voltage >2001V (per MIL-STD-883, Method 3015)
- Latch-Up Current..... >200 mA

Operating Range

Range	Ambient Temperature	V _{CC}
Commercial	0°C to +70°C	5V ±10%
Industrial ^[1]	-40°C to +85°C	5V ±10%
Military ^[2]	-55°C to +125°C	5V ±10%

Electrical Characteristics^[3, 4]

Parameter	Description	Test Conditions	CY7C276-25 CY7C276-30 CY7C276-35		Unit	
			Min.	Max.		
V _{OH}	Output HIGH Voltage	V _{CC} = Min., I _{OH} = -2.0 mA	2.4		V	
V _{OL}	Output LOW Voltage	V _{CC} = Min., I _{OL} = 8.0 mA (6.0 mA Mil)		0.4	V	
V _{IH}	Input HIGH Level	Guaranteed Input Logical HIGH Voltage for All Inputs	2.0	V _{CC}	V	
V _{IL}	Input LOW Level	Guaranteed Input Logical LOW Voltage for All Inputs	-3.0	0.8	V	
I _{IX}	Input Leakage Current	GND ≤ V _{IN} ≤ V _{CC}	-10	+10	μA	
V _{CD}	Input Clamp Diode Voltage		Note 3		μA	
I _{OZ}	Output Leakage Current	V _{CC} = Max., V _{OL} ≤ V _{OUT} ≤ V _{OH} , Output Disabled	-40	+40	μA	
I _{OS}	Output Short Circuit Current	V _{CC} = Max., V _{OUT} = 0.0V ^[5]	-20	-90	mA	
I _{CC}	Power Supply Current	V _{CC} = Max., I _{OUT} = 0.0 mA	Com'l		175	mA
			Military		200	mA

Capacitance^[3]

Parameter	Description	Test Conditions	Max.	Unit
C _{IN}	Input Capacitance	T _A = 25°C, f = 1 MHz, V _{CC} = 5.0V	10	pF
C _{OUT}	Output Capacitance		10	pF

Notes:

1. Contact a Cypress representative for industrial temperature range specifications.
2. T_A is the "instant on" case temperature
3. See Introduction to CMOS PROMs in this Data Book for general information on testing.
4. See the last page of this specification for Group A subgroup testing information.
5. For test purposes, not more than one output at a time should be shorted. Short circuit test duration should not exceed 30 seconds.

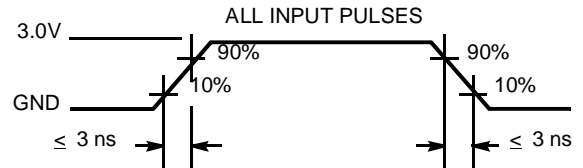
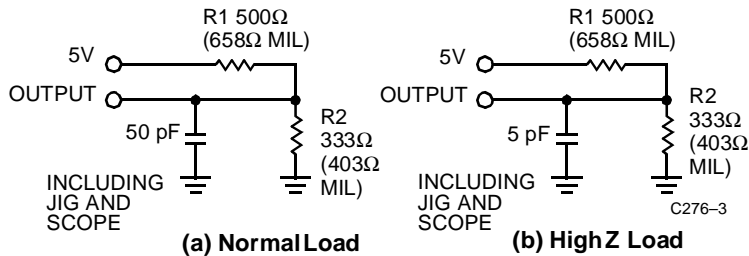
AC Test Loads and Waveforms

C276-4

Equivalent to: THÉVENIN EQUIVALENT

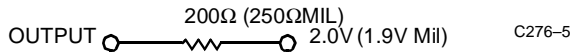
Switching Characteristics Over the Operating Range^[3,4]

Parameter	Description	CY7C276-25		CY7C276-30		CY7C276-35		Unit
		Min.	Max.	Min.	Max.	Min.	Max.	
t_{AA}	Address to Output Data Valid		25		30		35	ns
t_{CSOV}	CS Active to Output Valid		13		15		18	ns
t_{CSOZ}	CS Inactive to High Z Output		13		15		18	ns
t_{OEV}	OE Active to Output Valid		11		12		15	ns
t_{OEZ}	OE Inactive to High Z Output		11		12		15	ns

Erase Characteristics

The recommended dose of ultraviolet light for erasure is a wavelength of 2537 Angstroms for a minimum dose (UV intensity multiplied by exposure time) of 25 Wsec/cm². For an ultraviolet lamp with a 12 mW/cm² power rating the exposure time would be approximately 35 minutes. The 7C276 needs to be within 1 inch of the lamp during erasure. Permanent dam-

age may result if the EPROM is exposed to high-intensity UV light for an extended period of time. 7258 Wsec/cm² is the recommended maximum dosage.

Wavelengths of light less than 4000 Angstroms begin to erase the 7C276 in the windowed package. For this reason, an opaque label should be placed over the window if the EPROM is exposed to sunlight or fluorescent lighting for extended periods of time.

Switching Waveforms

Read Operation Timing Diagram ^[6]

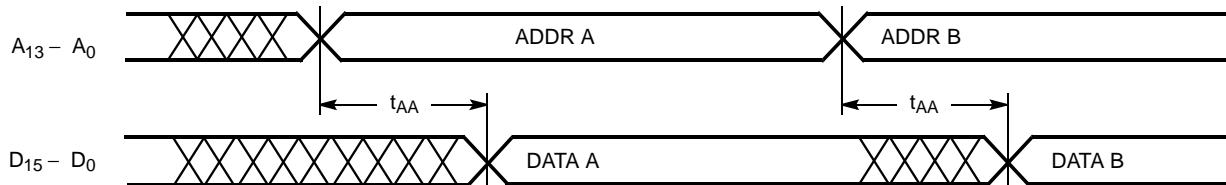

C276-6

Chip Select and Output Enable Timing Diagrams

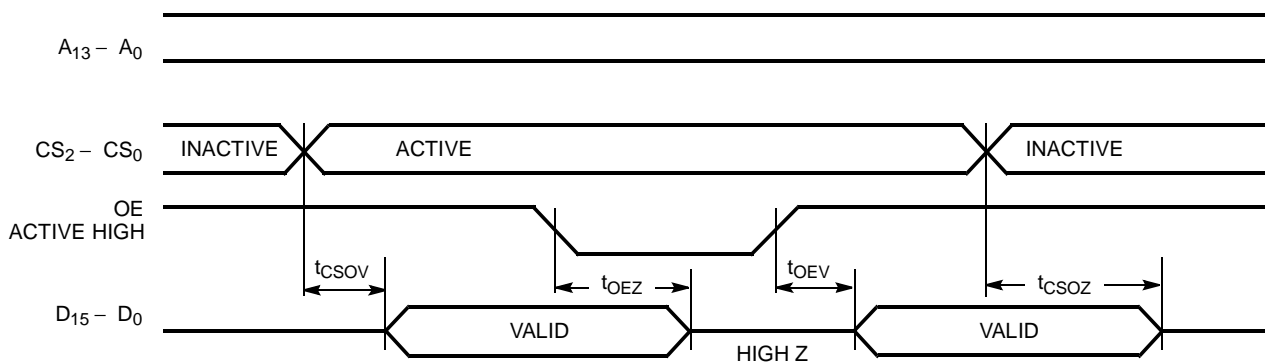

C276-7

Notes:

6. CS₂ - CS₀, OE assumed active.

Architecture Configuration Bits

The CY7C276 has four user-programmable options in addition to the reprogrammable data array. For detailed programming information contact your local Cypress representative.

The programmable options determine the active polarity for the three chip selects (CS₂ - CS₀) and OE. When these control bits are programmed with a 0 the inputs are active LOW. When these control bits are programmed with a 1 the inputs are active HIGH.

Programming Information

Programming support is available from Cypress as well as from a number of third-party software vendors. For detailed programming information, including a listing of software packages, please see the PROM Programming Information located at the end of this section. Programming algorithms can be obtained from any Cypress representative.

Table 1. Control Word for Architecture Configuration

Control Option	Control Word		Function
	Bit	Programmed Level	
OE	D ₀	0=Default 1=Programmed	OE Active LOW OE Active HIGH
CS ₀	D ₁₂	0=Default 1=Programmed	CS ₀ Active LOW CS ₀ Active HIGH
CS ₁	D ₁₃	0=Default 1=Programmed	CS ₁ Active LOW CS ₁ Active HIGH
CS ₂	D ₁₄	0=Default 1=Programmed	CS ₂ Active LOW CS ₂ Active HIGH

Bit Map

Programmer Address (Hex)	RAM Data
0000	Data
.	.
.	.
3FFF	Data
4000	Control Word

Control Word (4000H)

D15 D0
X CS2 CS1 CS0 X X X X X X X X 1 X X OE

Table 2. Program Mode Table

Mode	V _{PP}	$\overline{\text{PGM}}$	$\overline{\text{VFY}}$	D ₀ – D ₁₅
Program Inhibit	V _{PP}	V _{IHP}	V _{IHP}	High Z
Program Enable	V _{PP}	V _{ILP}	V _{IHP}	Data
Program Verify	V _{PP}	V _{IHP}	V _{ILP}	Data

Table 3. Configuration Mode Table

Mode	V _{PP}	$\overline{\text{PGM}}$	$\overline{\text{VFY}}$	A ₂	D ₀ – D ₁₅
Program Inhibit	V _{PP}	V _{IHP}	V _{IHP}	V _{PP}	High Z
Program Control Word	V _{PP}	V _{ILP}	V _{IHP}	V _{PP}	Control Word
Verify Control Word	V _{PP}	V _{IHP}	V _{ILP}	V _{PP}	Control Word

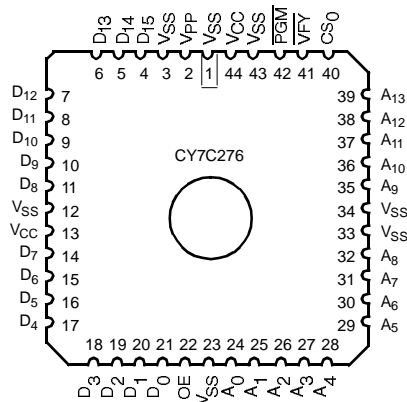

C276-8

Figure 1. Programming Pinout

Typical DC and AC Characteristics

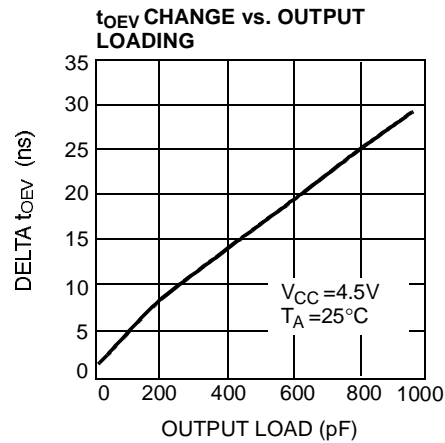
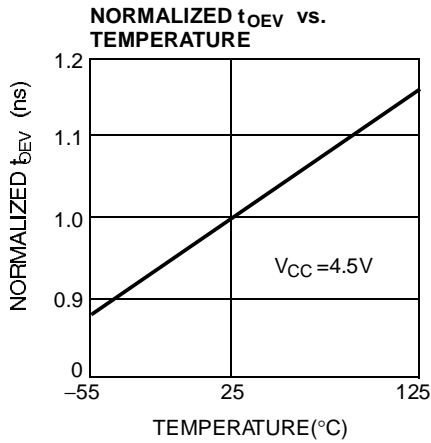
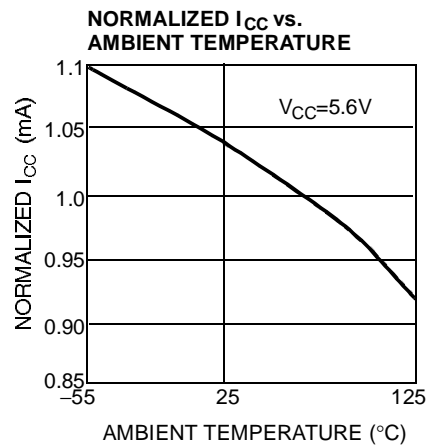
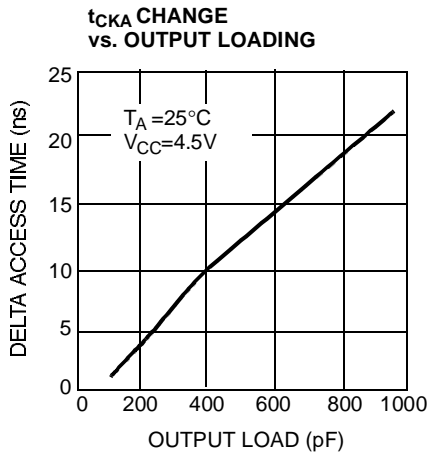
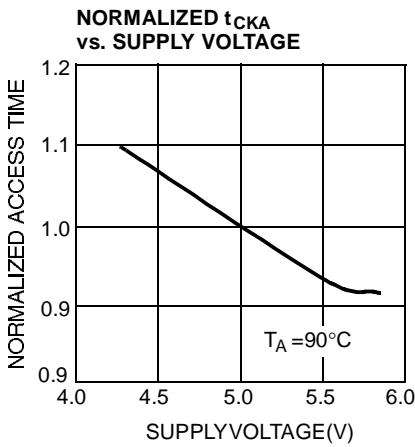
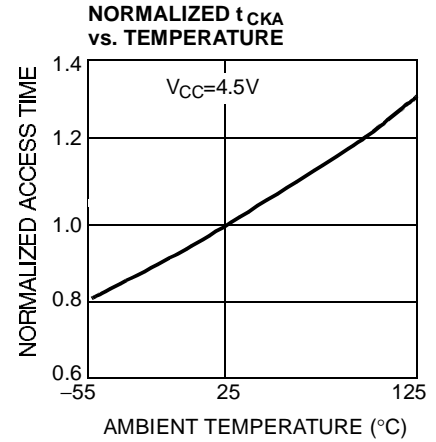
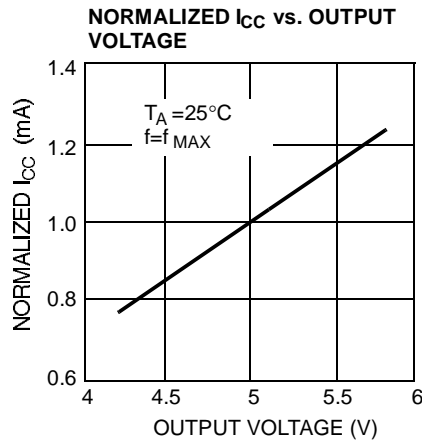
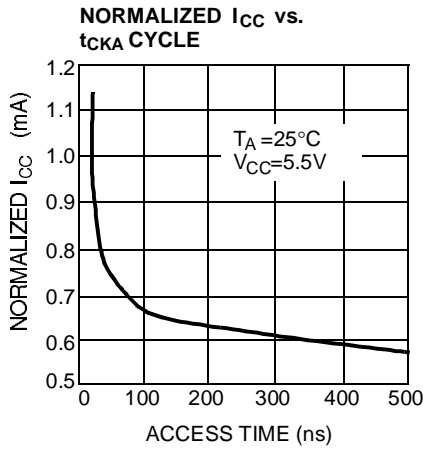

Ordering Information^[7]

Speed (ns)	Ordering Code	Package Name	Package Type	Operating Range
25	CY7C276-25HC	H67	44-Pin Windowed Leaded Chip Carrier	Commercial
	CY7C276-25JC	J67	44-Lead Plastic Leaded Chip Carrier	
	CY7C276-25HMB	H67	44-Pin Windowed Leaded Chip Carrier	Military
	CY7C276-25QMB	Q67	44-Pin Windowed Leadless Chip Carrier	
30	CY7C276-30HC	H67	44-Pin Windowed Leaded Chip Carrier	Commercial
	CY7C276-30JC	J67	44-Lead Plastic Leaded Chip Carrier	
	CY7C276-30HMB	H67	44-Pin Windowed Leaded Chip Carrier	Military
	CY7C276-30QMB	Q67	44-Pin Windowed Leadless Chip Carrier	
35	CY7C276-35HC	H67	44-Pin Windowed Leaded Chip Carrier	Commercial
	CY7C276-35JC	J67	44-Lead Plastic Leaded Chip Carrier	
	CY7C276-35HMB	H67	44-Pin Windowed Leaded Chip Carrier	Military
	CY7C276-35QMB	Q67	44-Pin Windowed Leadless Chip Carrier	

Notes:

7. Most of the above products are available in industrial temperature range. Contact a Cypress representative for specifications and product availability.

**MILITARY SPECIFICATIONS
Group A Subgroup Testing**
DC Characteristics

Parameter	Subgroups
V_{OH}	1, 2, 3
V_{OL}	1, 2, 3
V_{IH}	1, 2, 3
V_{IL}	1, 2, 3
I_{IX}	1, 2, 3
I_{OZ}	1, 2, 3
I_{CC}	1, 2, 3

Switching Characteristics

Parameter	Subgroups
t_{AA}	7, 8, 9, 10, 11
t_{CSOV}	7, 8, 9, 10, 11
t_{OEV}	7, 8, 9, 10, 11

Document #: 38-00183-D

Package Diagrams

44-Pin Windowed Leaded Chip Carrier H67

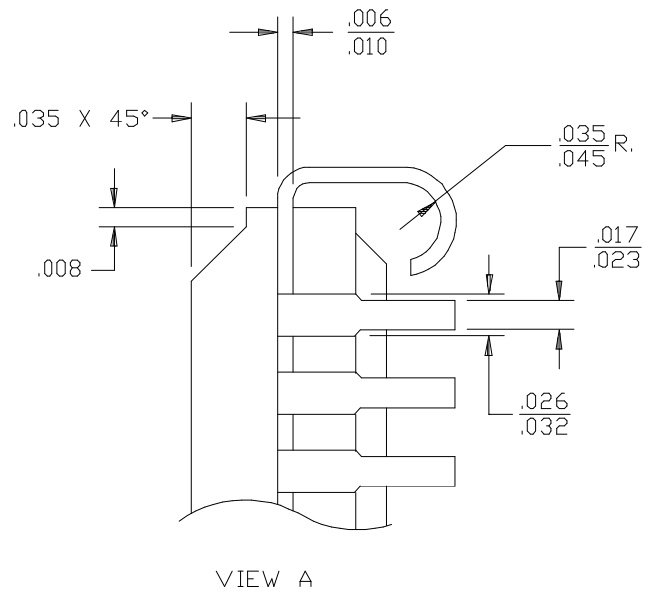
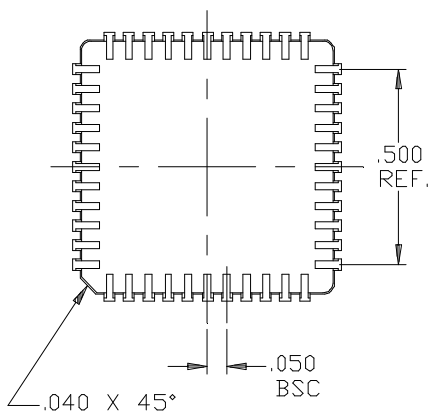
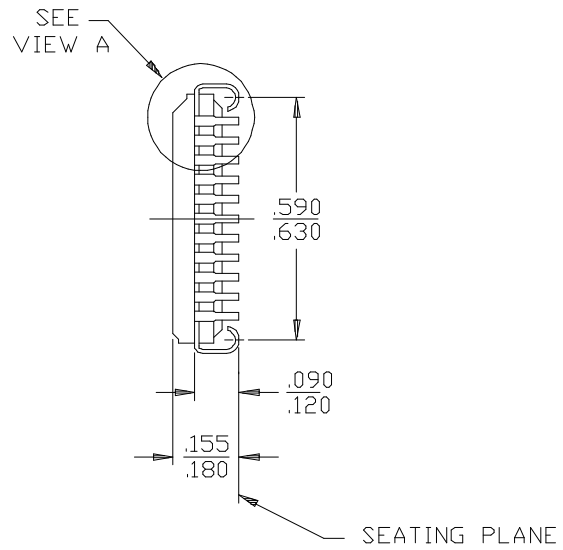
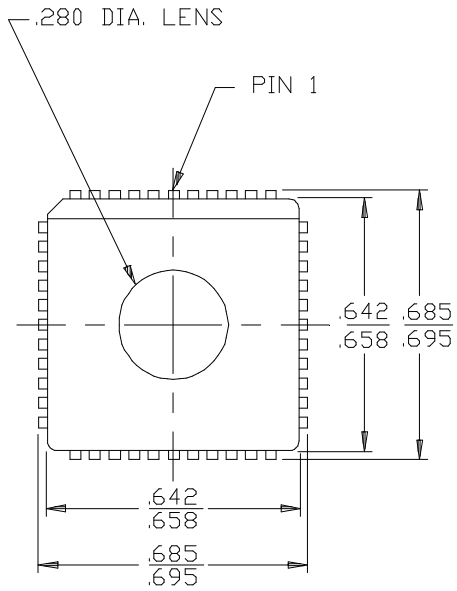

Package Diagrams (continued)

44-Lead Plastic Leaded Chip Carrier J67

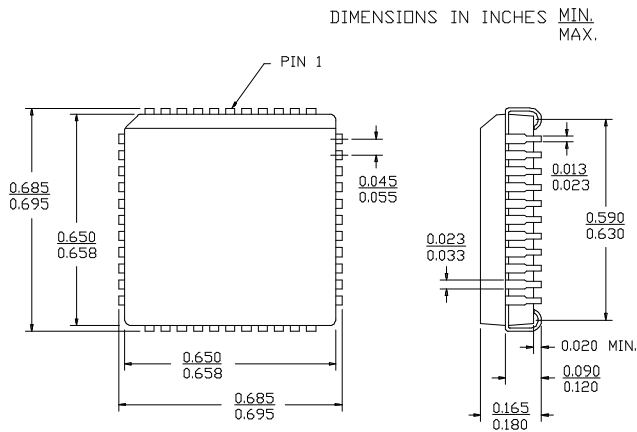

44-Square Leadless Chip Carrier L67
MIL-STD-1835 C-5

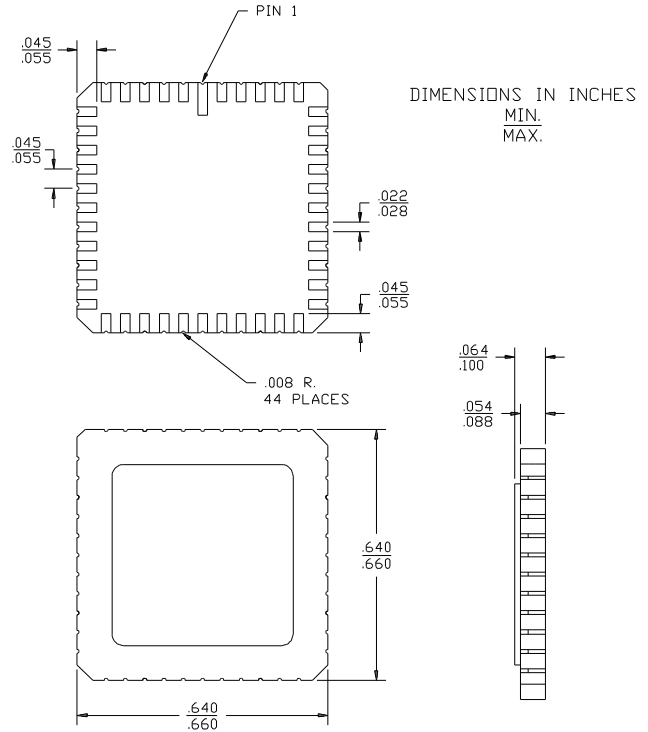

44-Pin Windowed Leadless Chip Carrier Q67

MIL-STD-1835 C-5

