



CYPRESS

CY7C346B

128-Macrocell MAX® EPLD

Features

- 128 macrocells in 8 LABs
- 20 dedicated inputs, up to 64 bidirectional I/O pins
- Programmable interconnect array
- Advanced 0.65-micron CMOS technology to increase performance
- Available in 84-pin CLCC, PLCC, and 100-pin PGA, PQFP

Functional Description

The CY7C346B is an Erasable Programmable Logic Device (EPLD) in which CMOS EPROM cells are used to configure logic functions within the device. The MAX architecture is 100% user-configurable, allowing the device to accommodate a variety of independent logic functions.

The 128 macrocells in the CY7C346B are divided into 8 Logic Array Blocks (LABs), 16 per LAB. There are 256 expander product terms, 32 per LAB, to be used and shared by the macrocells within each LAB.

Each LAB is interconnected through the programmable interconnect array, allowing all signals to be routed throughout the chip.

The speed and density of the CY7C346B allow it to be used in a wide range of applications, from replacement of large amounts of 7400-series TTL logic, to complex controllers and multifunction chips. With greater than 25 times the functionality of 20-pin PLDs, the CY7C346B allows the replacement of over 50 TTL devices. By replacing large amounts of logic, the CY7C346B reduces board space, part count, and increases system reliability.

Logic Block Diagram

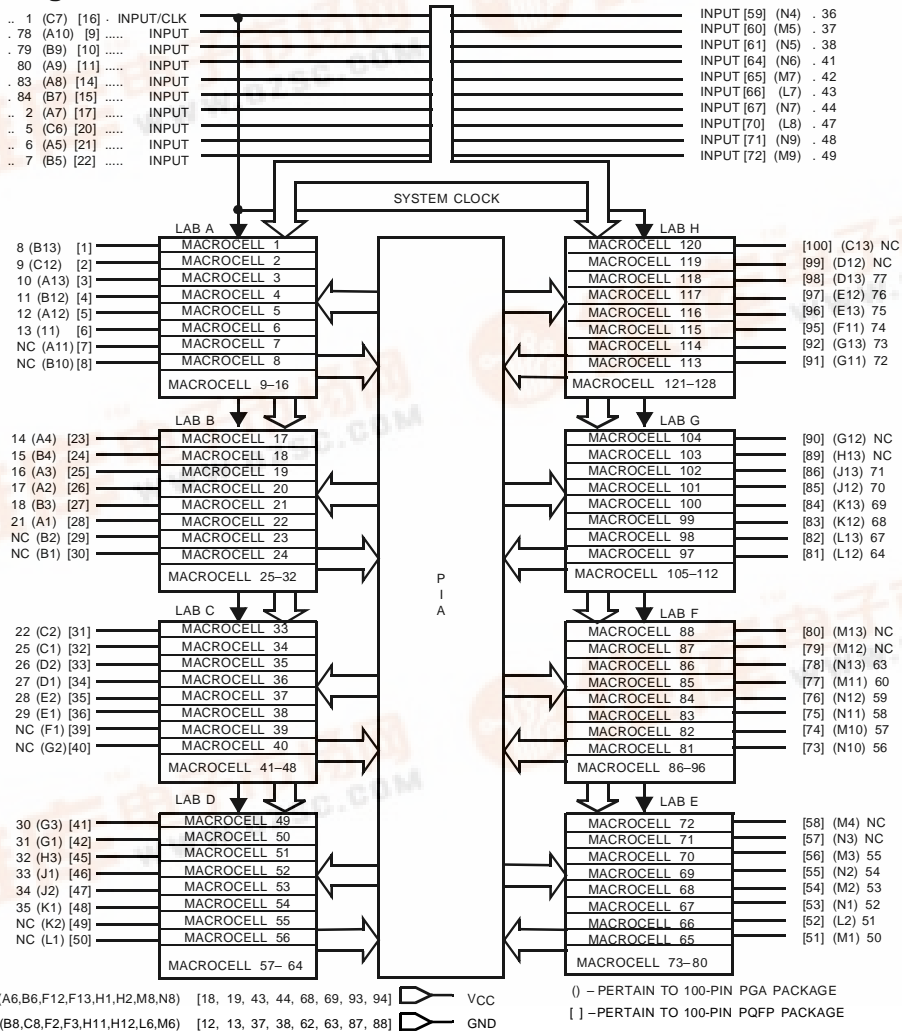

C346B-1



Selection Guide

| | 7C346B-25 | 7C346B-35 |
|--------------------------|-----------|-----------|
| Maximum Access Time (ns) | 25 | 35 |

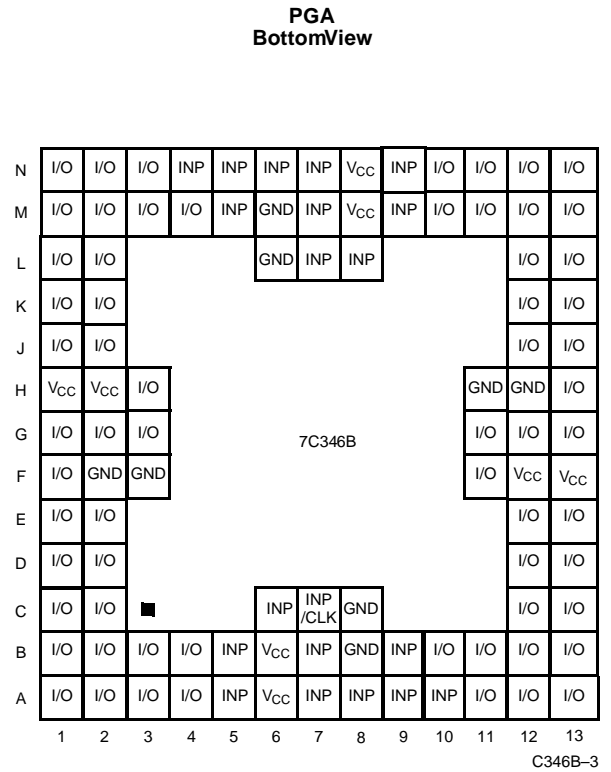
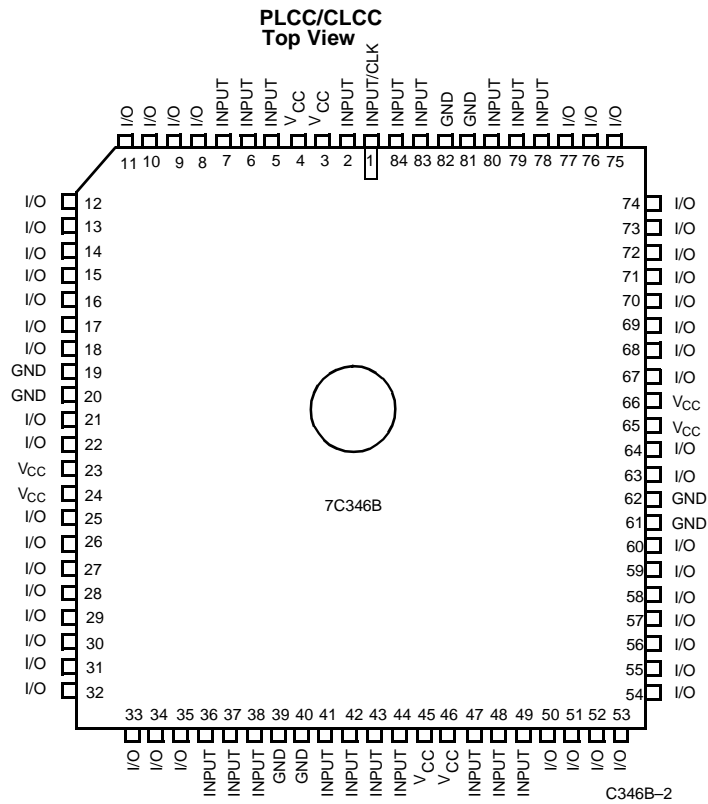
Pin Configurations

Pin Configurations (continued)

PQFP
Top View

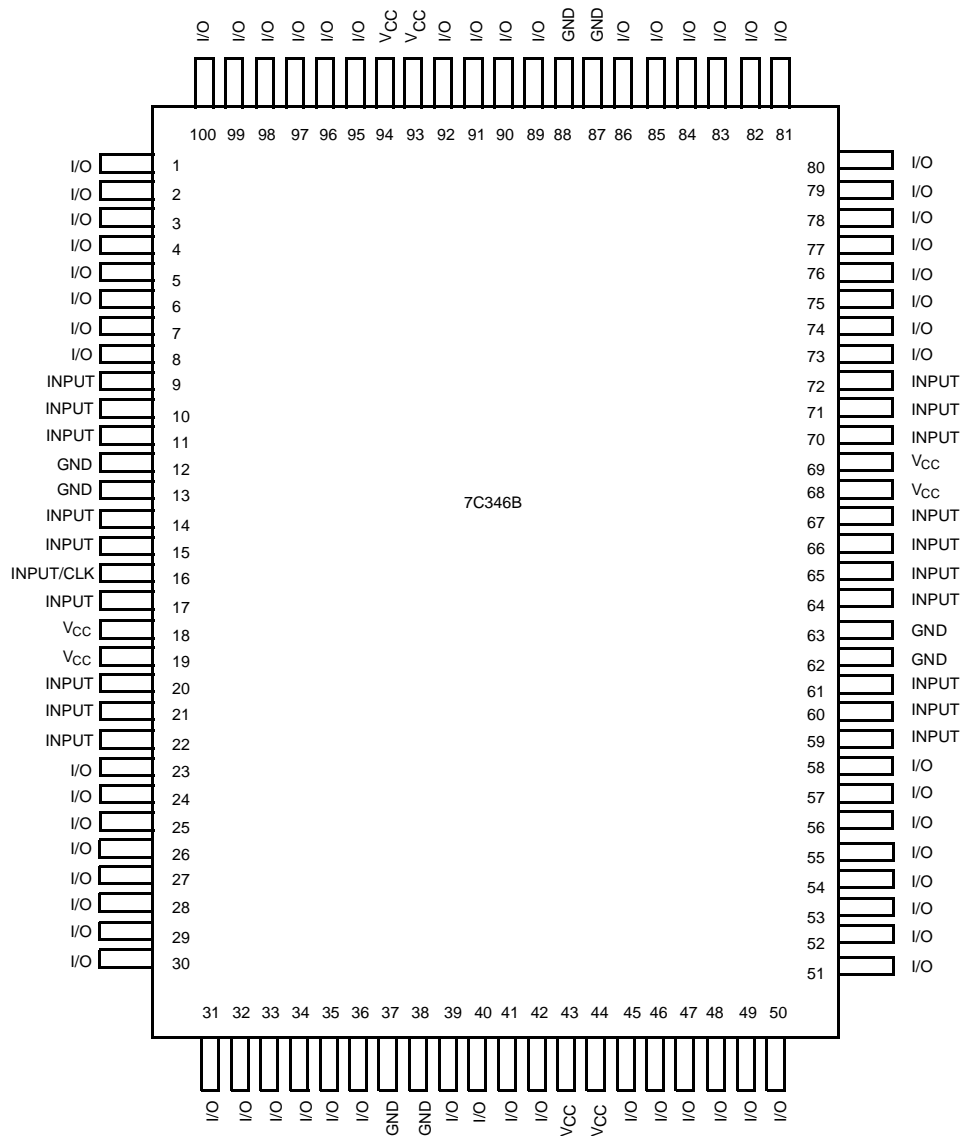

Maximum Ratings

(Above which the useful life may be impaired. For user guidelines, not tested.)

| | |
|---|-----------------|
| Storage Temperature | -65°C to +135°C |
| Ambient Temperature with Power Applied | -65°C to +135°C |
| Maximum Junction Temperature (under bias) | 150°C |
| Supply Voltage to Ground Potential ^[1] | -2.0V to +7.0V |

| | |
|--|------------------|
| DC Output Current per Pin ^[1] | -25 mA to +25 mA |
| DC Input Voltage ^[1] | -2.0V to +7.0V |

Operating Range

| Range | Ambient Temperature | V _{CC} |
|------------|---------------------|-----------------|
| Commercial | 0°C to +70°C | 5V ± 5% |
| Industrial | -40°C to +85°C | 5V ± 10% |

Electrical Characteristics Over the Operating Range

| Parameter | Description | Test Conditions | Min. | Max. | Unit |
|-----------------|-----------------------------|--|-----------|-----------------------|------|
| V _{CC} | Supply voltage | Maximum V _{CC} rise time is 10 ms | 4.75(4.5) | 5.25(5.5) | V |
| V _{OH} | Output HIGH Voltage | I _{OH} = -4 mA DC ^[2] | 2.4 | | V |
| V _{OL} | Output LOW Voltage | I _{OL} = 8 mA DC ^[2] | | 0.45 | V |
| V _{IH} | Input HIGH Voltage | | 2.0 | V _{CC} + 0.3 | V |
| V _{IL} | Input LOW Voltage | | -0.3 | 0.8 | V |
| I _{IX} | Input Current | V _I = V _{CC} or ground | -10 | +10 | μA |
| I _{OZ} | Output Leakage Current | V _O = V _{CC} or ground | -40 | +40 | μA |
| t _R | Recommended Input Rise Time | | | 100 | ns |
| t _F | Recommended Input Fall Time | | | 100 | ns |

Capacitance

| Parameter | Description | Test Conditions | Max. | Unit |
|------------------|--------------------|------------------------------------|------|------|
| C _{IN} | Input Capacitance | V _{IN} = 0V, f = 1.0 MHz | 10 | pF |
| C _{OUT} | Output Capacitance | V _{OUT} = 0V, f = 1.0 MHz | 20 | pF |

Notes:

- Minimum DC input is -0.3V. During transactions, the inputs may undershoot to -2.0V or overshoot to 7.0V for input currents less than 100 mA and periods shorter than 20 ns.
- The I_{OH} parameter refers to high-level TTL output current; the I_{OL} parameter refers to low-level TTL output current.

AC Test Loads and Waveforms

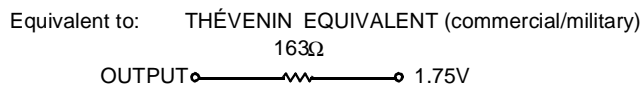
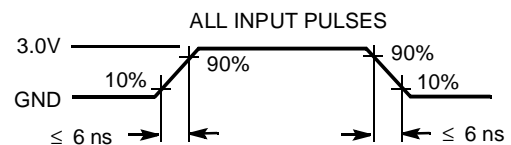
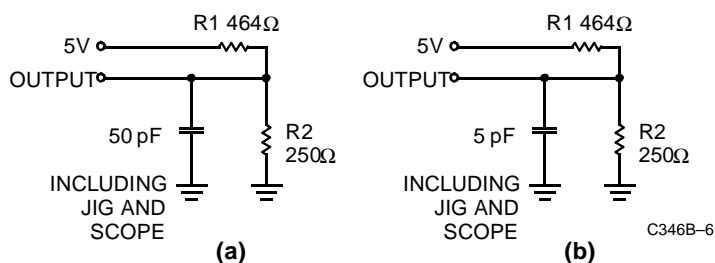

C346B-6

C346B-7

Logic Array Blocks

There are 8 logic array blocks in the CY7C346B. Each LAB consists of a macrocell array containing 16 macrocells, an expander product term array containing 32 expanders, and an I/O block. The LAB is fed by the programmable interconnect array and the dedicated input bus. All macrocell feedbacks go to the macrocell array, the expander array, and the programmable interconnect array. Expanders feed themselves and the macrocell array. All I/O feedbacks go to the programmable interconnect array so that they may be accessed by macrocells in other LABs as well as the macrocells in the LAB in which they are situated.

Externally, the CY7C346B provides 20 dedicated inputs, one of which may be used as a system clock. There are 64 I/O pins that may be individually configured for input, output, or bidirectional data flow.

Programmable Interconnect Array

The Programmable Interconnect Array (PIA) solves interconnect limitations by routing only the signals needed by each logic array block. The inputs to the PIA are the outputs of every macrocell within the device and the I/O pin feedback of every pin on the device.

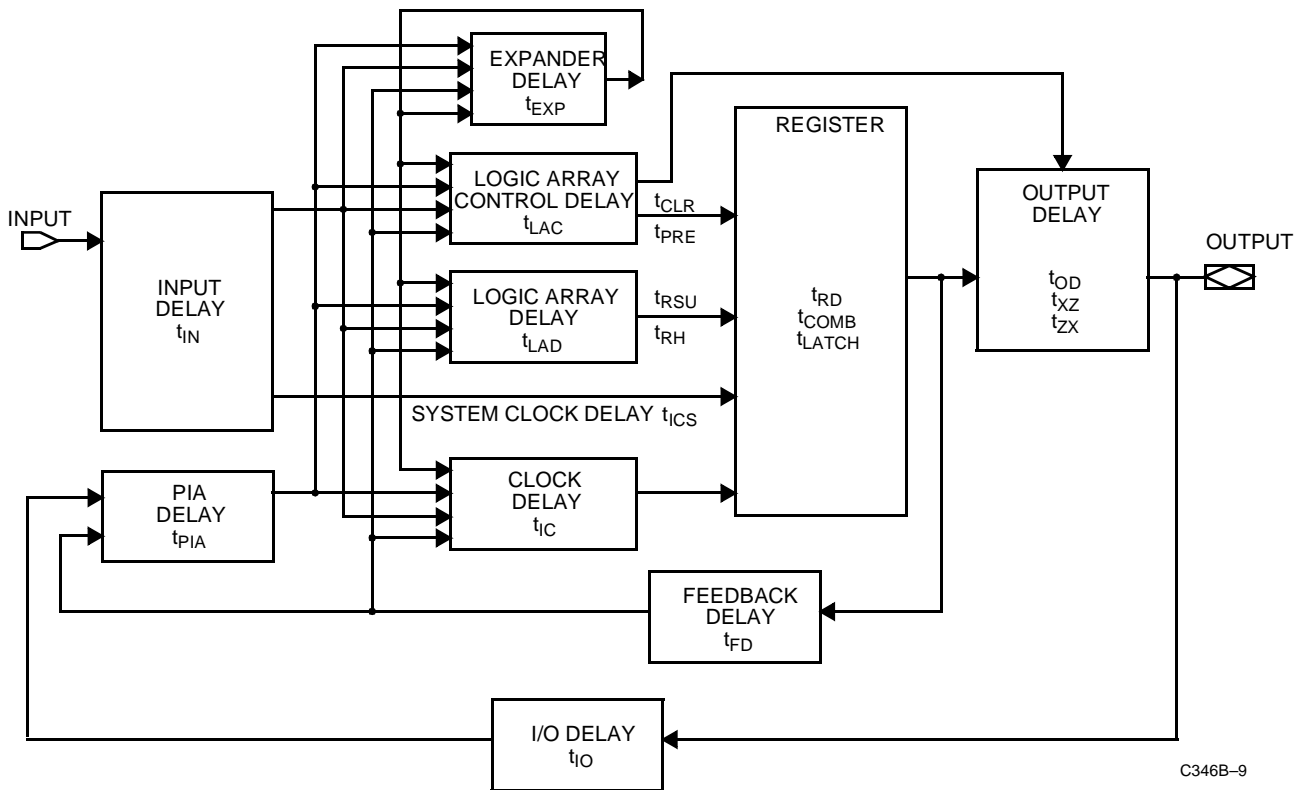

C346B-9

Figure 1. CY7C346B Internal Timing Model

Design Recommendations

Operation of the devices described herein with conditions above those listed under "Maximum Ratings" may cause permanent damage to the device. This is a stress rating only and functional operation of the device at these or any other conditions above those indicated in the operational sections of this data sheet is not implied. Exposure to absolute maximum ratings conditions for extended periods of time may affect device reliability. The CY7C346B contains circuitry to protect device pins from high static voltages or electric fields, but normal precautions should be taken to avoid application of any voltage higher than the maximum rated voltages.

For proper operation, input and output pins must be constrained to the range $GND \leq (V_{IN} \text{ or } V_{OUT}) \leq V_{CC}$. Unused inputs must always be tied to an appropriate logic level (either V_{CC} or GND). Each set of V_{CC} and GND pins must be connected together directly at the device. Power supply decoupling capacitors of at least $0.2 \mu F$ must be connected between V_{CC} and GND . For the most effective decoupling, each V_{CC} pin should be separately decoupled to GND directly at the device. Decoupling capacitors should have good frequency response, such as monolithic ceramic types have.

Design Security

The CY7C346B contains a programmable design security feature that controls the access to the data programmed into the device. If this programmable feature is used, a proprietary design implemented in the device cannot be copied or retrieved. This enables a high level of design control to be obtained since programmed data within EPROM cells is invisible. The bit that controls this function, along with all other program data, may be reset simply by erasing the entire device.

The CY7C346B is fully functionally tested and guaranteed through complete testing of each programmable EPROM bit and all internal logic elements thus ensuring 100% programming yield.

The erasable nature of these devices allows test programs to be used and erased during early stages of the production flow. The devices also contain on-board logic test circuitry to allow verification of function and AC specification once encapsulated in non-windowed packages.

Typical I_{CC} vs. f_{MAX}

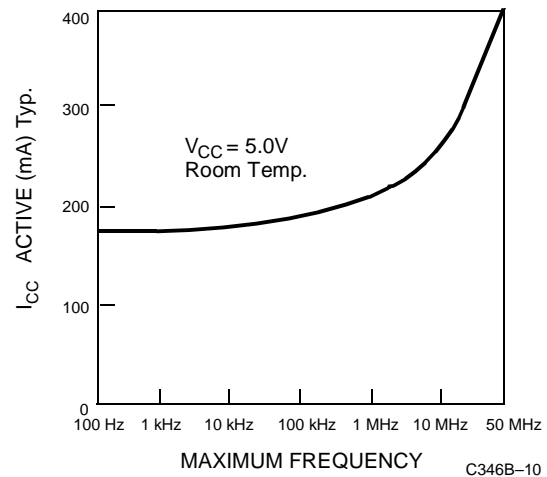

Output Drive Current

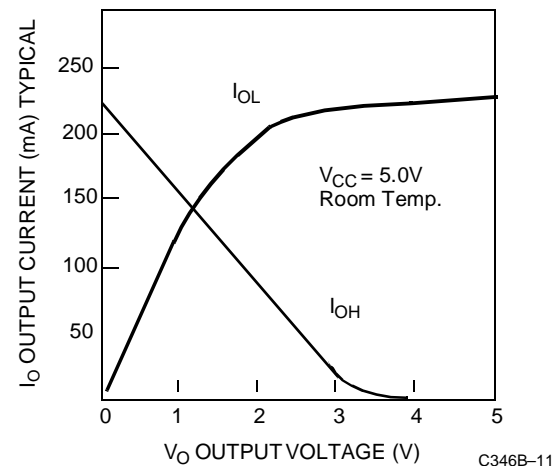

Timing Considerations

Unless otherwise stated, propagation delays do not include expanders. When using expanders, add the maximum expander delay t_{EXP} to the overall delay. Similarly, there is an additional t_{PIA} delay for an input from an I/O pin when compared to a signal from straight input pin.

When calculating synchronous frequencies, use t_{SU} if all inputs are on dedicated input pins. When expander logic is used in the data path, add the appropriate maximum expander delay, t_{EXP} to t_{SU} . Determine which of $1/(t_{WH} + t_{WL})$, $1/t_{CO1}$, or $1/(t_{EXP} + t_{SU})$ is the lowest frequency. The lowest of these frequencies is the maximum data path frequency for the synchronous configuration.

When calculating external asynchronous frequencies, use t_{AS1} if all inputs are on the dedicated input pins.

When expander logic is used in the data path, add the appropriate maximum expander delay, t_{EXP} to t_{AS1} . Determine which of $1/(t_{AWH} + t_{AWL})$, $1/t_{ACO1}$, or $1/(t_{EXP} + t_{AS1})$ is the lowest frequency. The lowest of these frequencies is the maximum data path frequency for the asynchronous configuration.

The parameter t_{OH} indicates the system compatibility of this device when driving other synchronous logic with positive input hold times, which is controlled by the same synchronous clock. If t_{OH} is greater than the minimum required input hold time of the subsequent synchronous logic, then the devices are guaranteed to function properly with a common synchronous clock under worst-case environmental and supply voltage conditions.

Commercial and Industrial External Synchronous Switching Characteristics Over Operating Range

| Parameter | Description | 7C346B-25 | | 7C346B-35 | | Unit |
|-----------|--|-----------|------|-----------|------|------|
| | | Min. | Max. | Min. | Max. | |
| t_{PD1} | Dedicated Input to Combinatorial Output Delay ^[3] | | 25 | | 35 | ns |
| t_{PD2} | I/O Input to Combinatorial Output Delay ^[3] | | 40 | | 55 | ns |
| t_{SU} | Global Clock Set-Up Time | 15 | | 25 | | ns |
| t_{CO1} | Synchronous Clock Input to Output Delay ^[3] | | 14 | | 20 | ns |
| t_H | Input Hold Time from Synchronous Clock Input | 0 | | 0 | | ns |
| t_{WH} | Synchronous Clock Input HIGH Time | 8 | | 12.5 | | ns |
| t_{WL} | Synchronous Clock Input LOW Time | 8 | | 12.5 | | ns |
| f_{MAX} | Maximum Register Toggle Frequency ^[4] | 62.5 | | 40 | | MHz |
| t_{CNT} | Minimum Global Clock Period | | 20 | | 30 | ns |
| t_{ODH} | Output Data Hold Time After Clock | 2 | | 2 | | ns |
| f_{CNT} | Maximum Internal Global Clock Frequency ^[5] | 50 | | 33.3 | | MHz |

Commercial and Industrial External Asynchronous Switching Characteristics Over Operating Range

| Parameter | Description | 7C346B-25 | | 7C346B-35 | | Unit |
|------------|---|-----------|------|-----------|------|------|
| | | Min. | Max. | Min. | Max. | |
| t_{ACO1} | Asynchronous Clock Input to Output Delay ^[3] | | 25 | | 35 | ns |
| t_{AS1} | Dedicated Input or Feedback Set-Up Time to Asynchronous Clock Input | 5 | | 10 | | ns |
| t_{AH} | Input Hold Time from Asynchronous Clock Input | 6 | | 10 | | ns |
| t_{AWH} | Asynchronous Clock Input HIGH Time ^[6] | 11 | | 16 | | ns |
| t_{AWL} | Asynchronous Clock Input LOW Time ^[6] | 9 | | 14 | | ns |
| t_{ACNT} | Minimum Internal Array Clock Frequency | | 20 | | 30 | ns |
| f_{ACNT} | Maximum Internal Array Clock Frequency ^[5] | 50 | | 33.3 | | MHz |

Notes:

- $C1 = 35$ pF.
- The f_{MAX} values represent the highest frequency for pipeline data.
- This parameter is measured with a 16-bit counter programmed into each LAB.
- This parameter is measured with a positive-edge-triggered clock at the register. For negative-edge clocking, the t_{ACH} and t_{ACL} parameter must be swapped.



Commercial and Industrial Internal Switching Characteristics Over Operating Range

| Parameter | Description | 7C346B-25 | | 7C346B-35 | | Unit |
|--------------------|---|-----------|------|-----------|------|------|
| | | Min. | Max. | Min. | Max. | |
| t _{IN} | Dedicated Input Pad and Buffer Delay | | 5 | | 11 | ns |
| t _{IO} | I/O Input Pad and Buffer Delay | | 6 | | 11 | ns |
| t _{EXP} | Expander Array Delay | | 12 | | 20 | ns |
| t _{LAD} | Logic Array Data Delay | | 12 | | 14 | ns |
| t _{LAC} | Logic Array Control Delay | | 10 | | 13 | ns |
| t _{OD} | Output Buffer and Pad Delay ^[3] | | 5 | | 6 | ns |
| t _{ZX} | Output Buffer Enable Delay ^[3] | | 10 | | 13 | ns |
| t _{XZ} | Output Buffer Disable Delay ^[7] | | 10 | | 13 | ns |
| t _{RSU} | Register Set-Up Time Relative to Clock Signal at Register | 6 | | 12 | | ns |
| t _{RH} | Register Hold Time Relative to Clock Signal at Register | 4 | | 8 | | ns |
| t _{LATCH} | Flow Through Latch Delay | | 3 | | 4 | ns |
| t _{RD} | Register Delay | | 1 | | 2 | ns |
| t _{COMB} | Transparent Mode Delay | | 3 | | 4 | ns |
| t _{IC} | Asynchronous Clock Logic Delay | | 14 | | 16 | ns |
| t _{ICS} | Synchronous Clock Delay | | 3 | | 1 | ns |
| t _{FD} | Feedback Delay | | 1 | | 2 | ns |
| t _{PRE} | Asynchronous Register Preset Time | | 5 | | 7 | ns |
| t _{CLR} | Asynchronous Register Clear Time | | 5 | | 7 | ns |
| t _{PIA} | Programmable Interconnect Array Delay Time | | 14 | | 20 | ns |

Note:

7. C1 = 5 pF.

Switching Waveforms

External Combinatorial

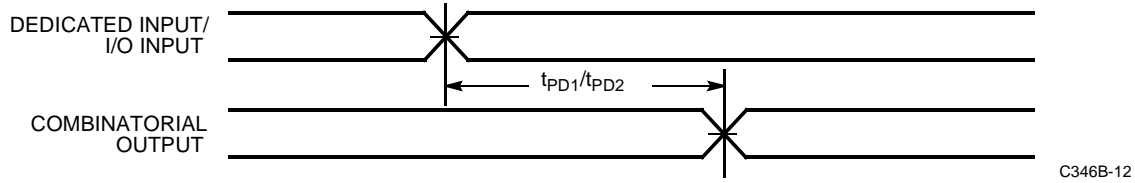

C346B-12

External Synchronous

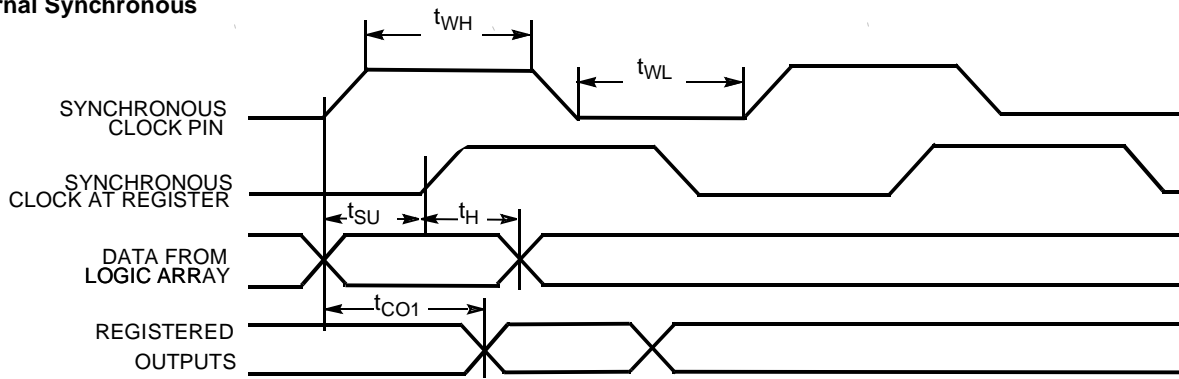

C346B-13

External Asynchronous

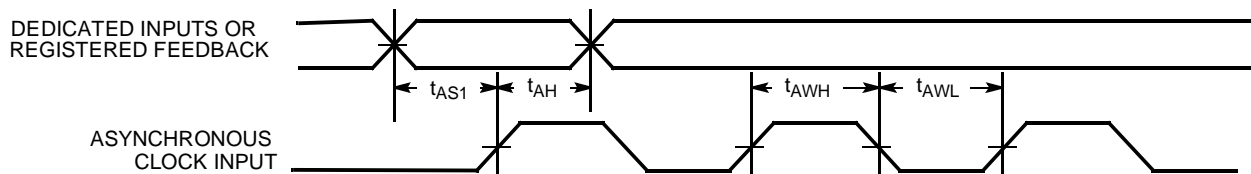

C346B-14

Internal Combinatorial

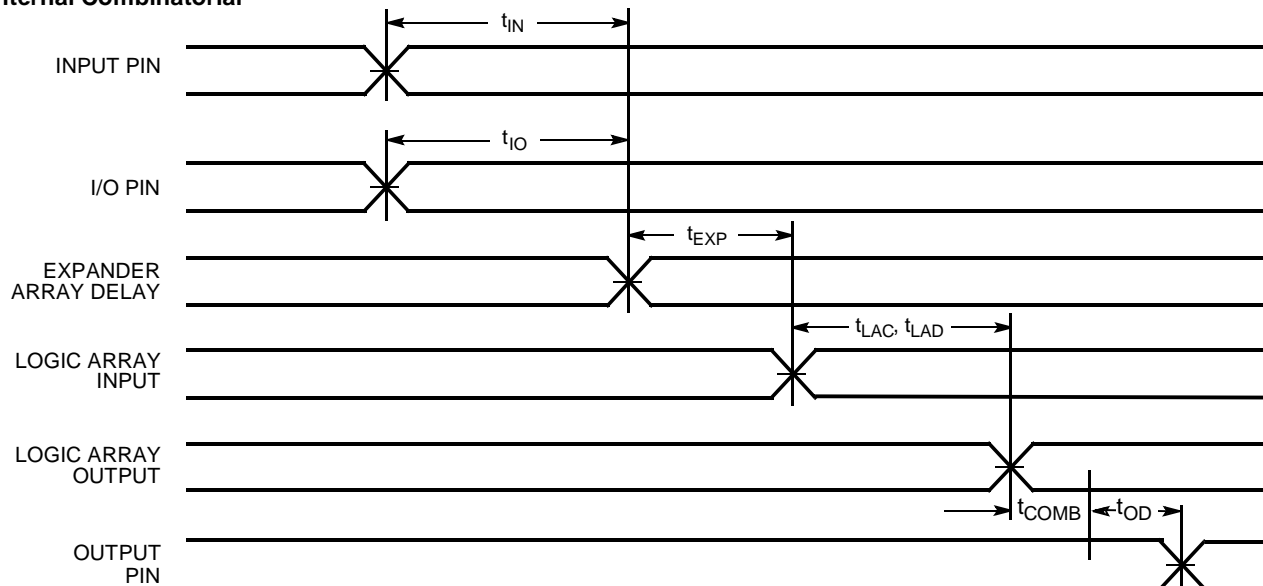

C346B-15

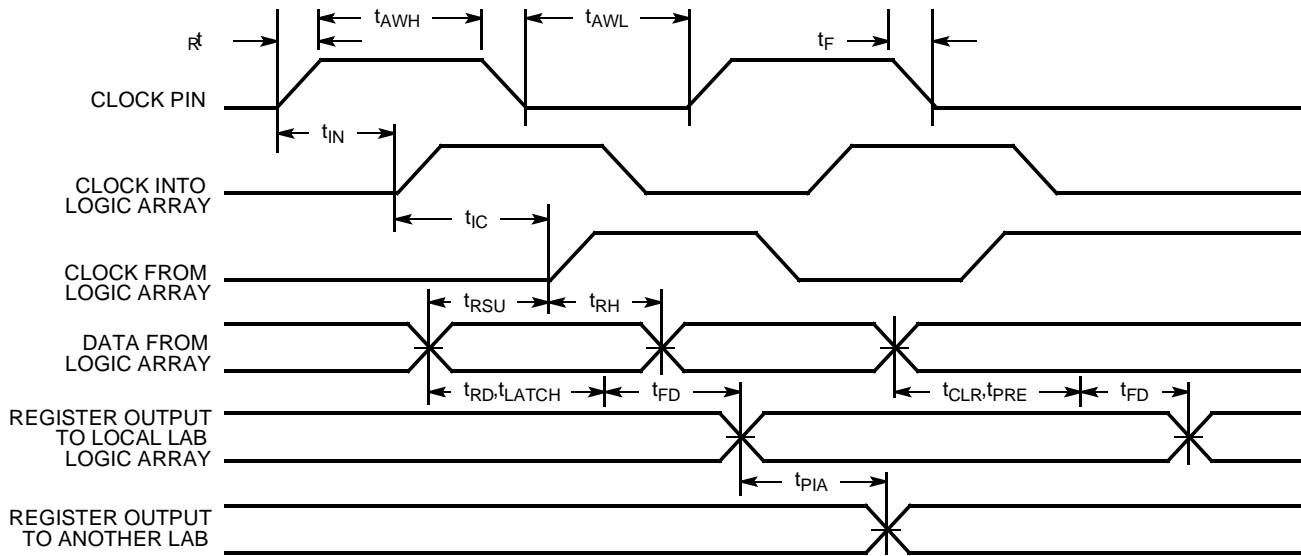
Switching Waveforms (continued)
Internal Asynchronous

C346B-16

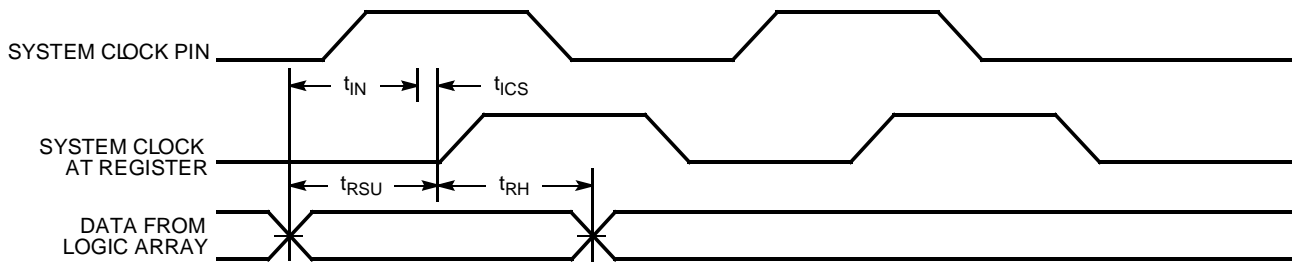
Internal Synchronous

C346B-17

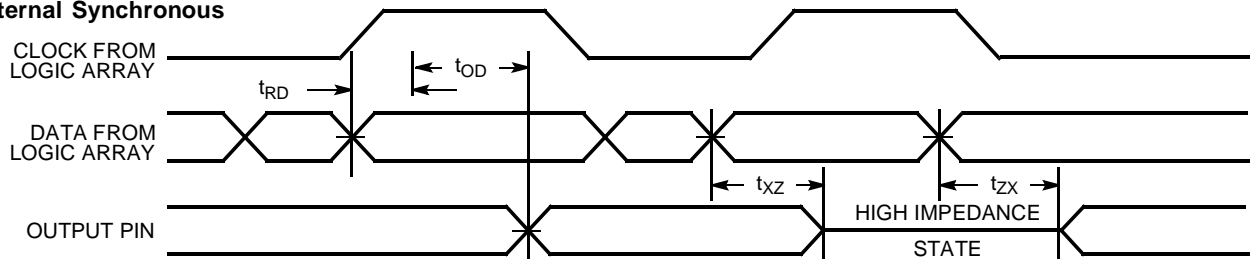
Internal Synchronous

C346B-18

**Ordering Information**

| Speed (ns) | Ordering Code | Package Name | Package Type | Operating Range |
|-------------------|----------------------|---------------------|---|------------------------|
| 25 | CY7C346B-25HC/HI | H84 | 84-Pin Windowed Leaded Chip Carrier | Commercial/Industrial |
| | CY7C346B-25JC/JI | J83 | 84-Lead Plastic Leaded Chip Carrier | |
| | CY7C346B-25NC/NI | N100 | 100-Lead Plastic Quad Flatpack | |
| | CY7C346B-25RC/RI | R100 | 100-Pin Windowed Ceramic Pin Grid Array | |
| 35 | CY7C346B-35HC/HI | H84 | 84-Pin Windowed Leaded Chip Carrier | Commercial/Industrial |
| | CY7C346B-35JC/JI | J83 | 84-Lead Plastic Leaded Chip Carrier | |
| | CY7C346B-35NC/NI | N100 | 100-Lead Plastic Quad Flatpack | |
| | CY7C346B-35RC/RI | R100 | 100-Pin Windowed Ceramic Pin Grid Array | |

Document #: 38-00861

MAX is a registered trademark of Altera Corporation.

Package Diagrams

84-Leaded Windowed Leaded Chip Carrier H84

DIMENSIONS IN INCHES

MIN.
MAX.

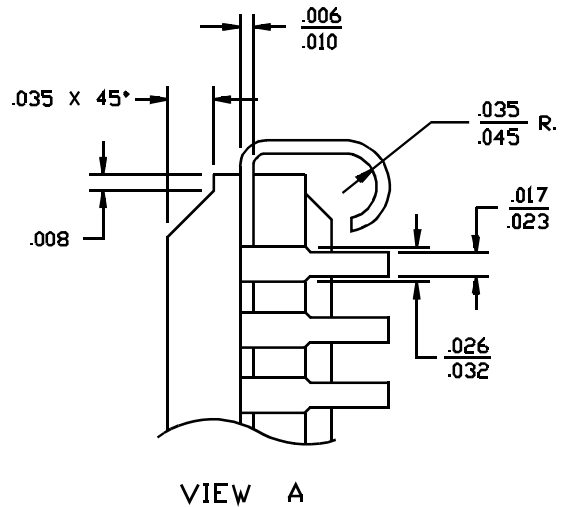
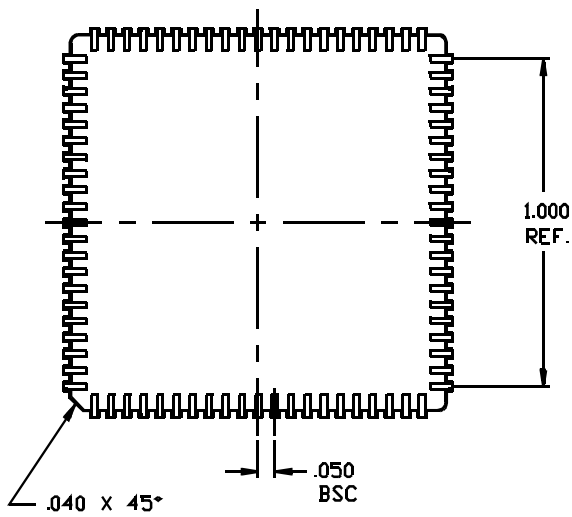
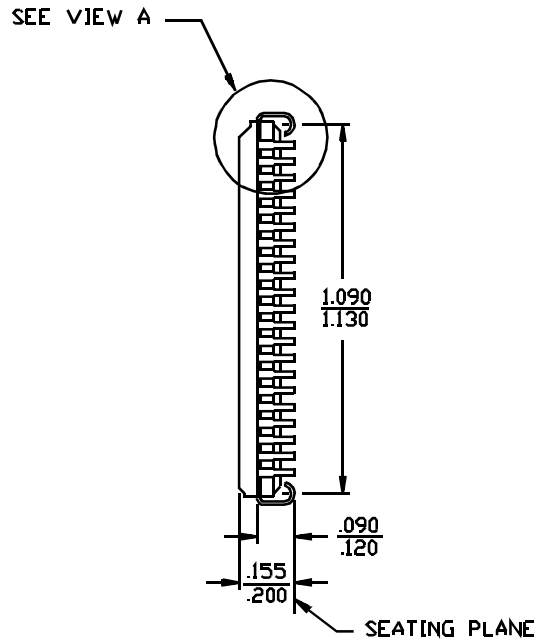
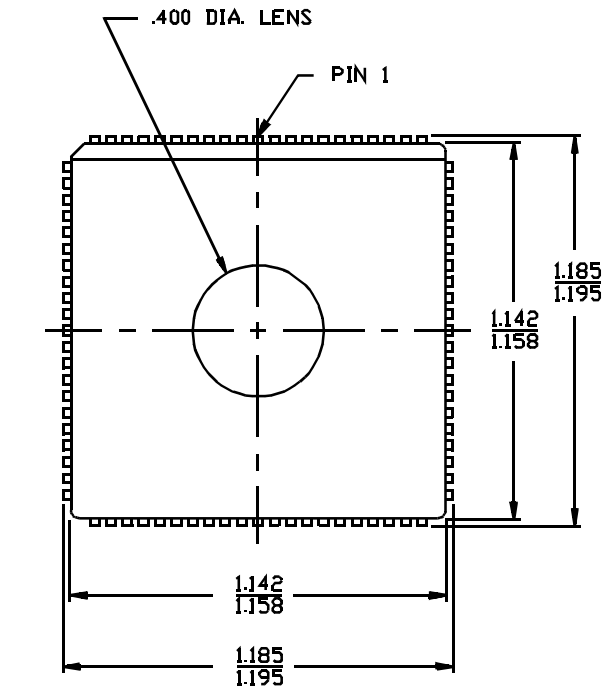

Package Diagrams (continued)

100-Lead Plastic Quad Flatpack N100

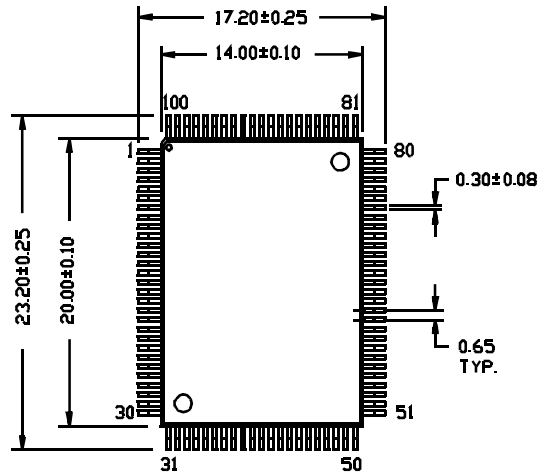

DIMENSIONS ARE IN MILLIMETERS.

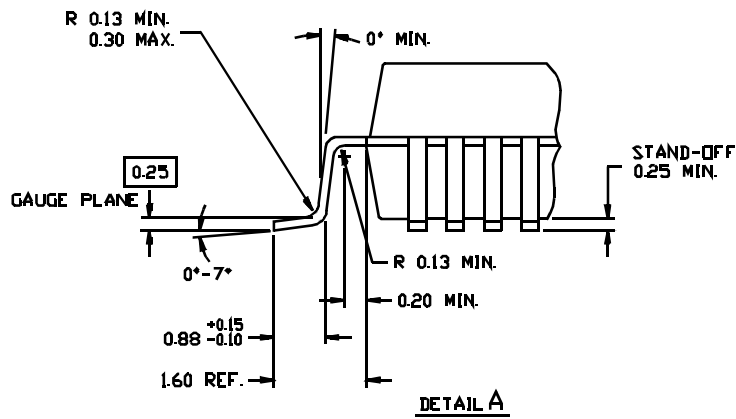
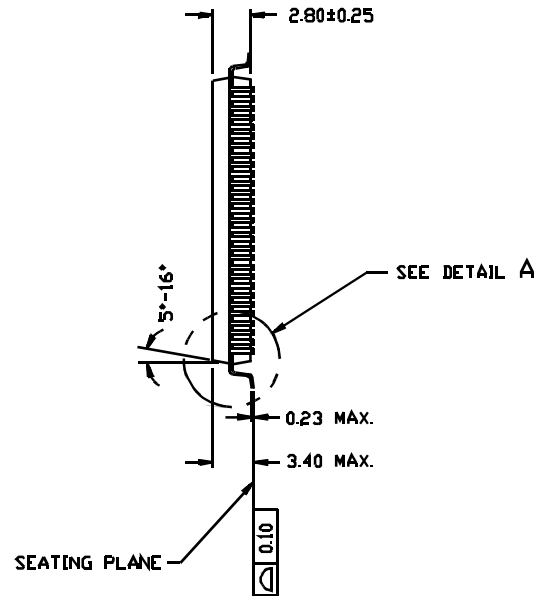

51-85052-A

Package Diagrams (continued)

100-Pin Windowed Ceramic Pin Grid Array R100

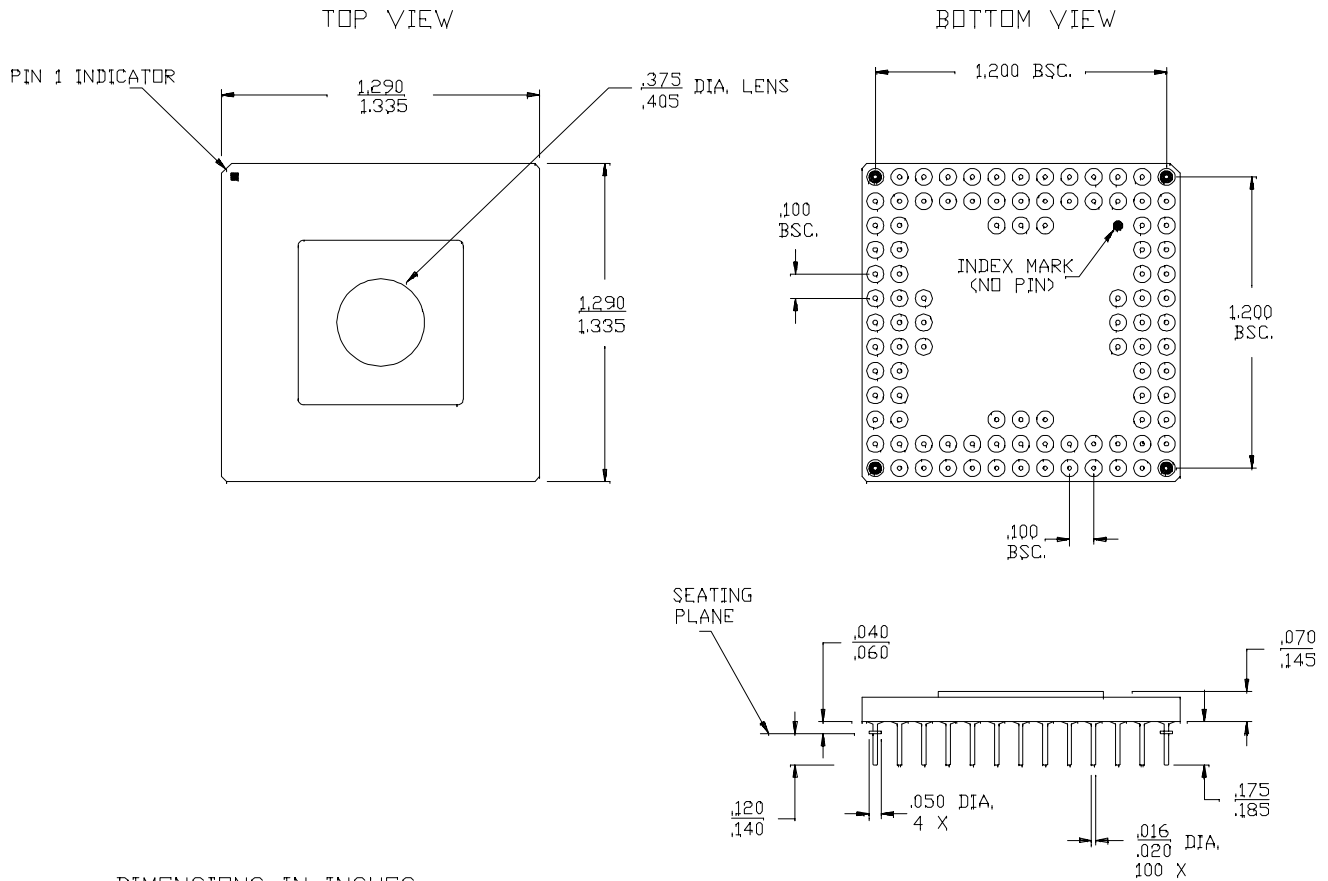

DIMENSIONS IN INCHES

MIN.
MAX.

51-80010-B