

## MC14500B

### Industrial Control Unit

The MC14500B Industrial Control Unit (ICU) is a single-bit CMOS processor. The ICU is designed for use in systems requiring decisions based on successive single-bit information. An external ROM stores the control program. With a program counter (and output latches and input multiplexers, if required) the ICU in a system forms a stored-program controller that replaces combinatorial logic. Applications include relay logic processing, serial data manipulation and control. The ICU also may control an MPU or be controlled by an MPU.

- 16 Instructions
- DC to 1.0 MHz Operation at  $V_{DD} = 5\text{ V}$
- On-Chip Clock (Oscillator)
- Executes One Instruction per Clock Cycle
- 3 to 18 V Operation
- Low Quiescent Current Characteristic of CMOS Devices
- Capable of Driving One Low-Power Schottky Load or Two Low-Power TTL Loads over Full Temperature Range

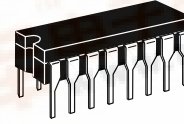

**L SUFFIX**  
 CERAMIC  
 CASE 620

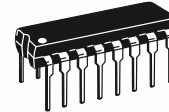

**P SUFFIX**  
 PLASTIC  
 CASE 648



**DW SUFFIX**  
 SOIC  
 CASE 751G

#### ORDERING INFORMATION

MC14XXXBCP	Plastic
MC14XXXBCL	Ceramic
MC14XXXBDW	SOIC

$T_A = -55^\circ$  to  $125^\circ\text{C}$  for all packages.

#### BLOCK DIAGRAM

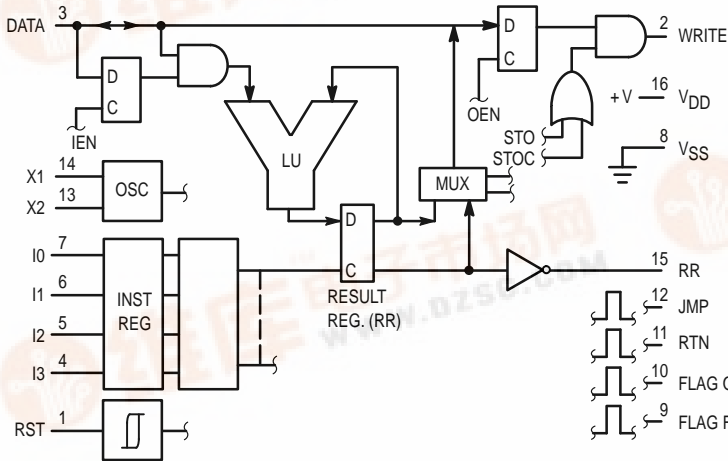

X1 — OSCILLATOR OUTPUT  
 X2 — OSCILLATOR INPUT

#### PIN ASSIGNMENT

RST	1	16	$V_{DD}$
WRITE	2	15	RR
DATA	3	14	X1
	4	13	X2
	5	12	JMP
	6	11	RTN
	7	10	FLAG O
$V_{SS}$	8	9	FLAG F

**MAXIMUM RATINGS\*** (Voltages Referenced to  $V_{SS}$ )

Symbol	Parameter	Value	Unit
$V_{DD}$	DC Supply Voltage	- 0.5 to + 18.0	V
$V_{in}, V_{out}$	Input or Output Voltage (DC or Transient)	- 0.5 to $V_{DD} + 0.5$	V
$I_{in}, I_{out}$	Input or Output Current (DC or Transient), per Pin	$\pm 10$	mA
$P_D$	Power Dissipation, per Package†	500	mW
$T_{stg}$	Storage Temperature	- 65 to + 150	°C
$T_L$	Lead Temperature (8-Second Soldering)	260	°C

This device contains protection circuitry to guard against damage due to high static voltages or electric fields. However, precautions must be taken to avoid applications of any voltage higher than maximum rated voltages to this high-impedance circuit. For proper operation,  $V_{in}$  and  $V_{out}$  should be constrained to the range  $V_{SS} \leq (V_{in} \text{ or } V_{out}) \leq V_{DD}$ . Unused inputs must always be tied to an appropriate logic voltage level (e.g., either  $V_{SS}$  or  $V_{DD}$ ). Unused outputs must be left open.

\* Maximum Ratings are those values beyond which damage to the device may occur.

† Temperature Derating:

Plastic "P and D/DW" Packages: - 7.0 mW/°C From 65°C To 125°C

Ceramic "L" Packages: - 12 mW/°C From 100°C To 125°C

**ELECTRICAL CHARACTERISTICS** (Voltages Referenced to  $V_{SS}$ )

Characteristic	Symbol	$V_{DD}$ Vdc	- 55°C		25°C			125°C		Unit	
			Min	Max	Min	Typ #	Max	Min	Max		
Output Voltage $V_{in} = V_{DD}$ or 0	$V_{OL}$	5.0	—	0.05	—	0	0.05	—	0.05	Vdc	
		10	—	0.05	—	0	0.05	—	0.05		
15		—	0.05	—	0	0.05	—	0.05			
$V_{in} = 0$ or $V_{DD}$	$V_{OH}$	5.0	4.95	—	4.95	5.0	—	4.95	—	Vdc	
		10	9.95	—	9.95	10	—	9.95	—		
		15	14.95	—	14.95	15	—	14.95	—		
Input Voltage RST, D, X2 ( $V_O = 4.5$ or $0.5$ Vdc) ( $V_O = 9.0$ or $1.0$ Vdc) ( $V_O = 13.5$ or $1.5$ Vdc)	$V_{IL}$	5.0	—	1.5	—	2.25	1.5	—	1.5	Vdc	
		10	—	3.0	—	4.50	3.0	—	3.0		
15		—	4.0	—	6.75	4.0	—	4.0			
( $V_O = 0.5$ or $4.5$ Vdc) ( $V_O = 1.0$ or $9.0$ Vdc) ( $V_O = 1.5$ or $13.5$ Vdc)	$V_{IH}$	5.0	3.5	—	3.5	2.75	—	3.5	—	Vdc	
		10	7.0	—	7.0	5.50	—	7.0	—		
		15	11	—	11	8.25	—	11	—		
Input Voltage # I0, I1, I2, I3 ( $V_O = 4.5$ or $0.5$ Vdc) ( $V_O = 9.0$ or $1.0$ Vdc) ( $V_O = 13.5$ or $1.5$ Vdc)	$V_{IL}$	5.0	—	0.8	—	1.1	0.8	—	0.8	Vdc	
		10	—	1.6	—	2.2	1.6	—	1.6		
15		—	2.4	—	3.4	2.4	—	2.4			
( $V_O = 0.5$ or $4.5$ Vdc) ( $V_O = 1.0$ or $9.0$ Vdc) ( $V_O = 1.5$ or $13.5$ Vdc)	$V_{IH}$	5.0	2.0	—	2.0	1.9	—	2.0	—	Vdc	
		10	6.0	—	6.0	3.1	—	6.0	—		
		15	10	—	10	4.3	—	10	—		
Output Drive Current Data, Write ( $V_{OH} = 4.6$ Vdc) ( $V_{OH} = 9.5$ Vdc) ( $V_{OH} = 13.5$ Vdc)	Source	$I_{OH}$	5.0	- 1.2	—	- 1.0	- 2.0	—	- 0.7	—	mAdc
			10	- 3.6	—	- 3.0	- 6.0	—	- 2.1	—	
15			- 7.2	—	- 6.0	- 12	—	- 4.2	—		
( $V_{OL} = 0.4$ Vdc) ( $V_{OL} = 0.5$ Vdc) ( $V_{OL} = 1.5$ Vdc)	Sink	$I_{OL}$	5.0	1.9	—	1.6	3.2	—	1.1	—	mAdc
			10	3.6	—	3.0	6.0	—	2.1	—	
			15	7.2	—	6.0	12	—	4.2	—	
Output Drive Current Other Outputs ( $V_{OH} = 2.5$ Vdc) ( $V_{OH} = 4.6$ Vdc) ( $V_{OH} = 9.5$ Vdc) ( $V_{OH} = 13.5$ Vdc)	Source	$I_{OH}$	5.0	- 3.0	—	- 2.4	- 4.2	—	- 1.7	—	mAdc
			5.0	- 0.64	—	- 0.51	- 0.88	—	- 0.36	—	
10			- 1.6	—	- 1.3	- 2.25	—	- 0.9	—		
15			- 4.2	—	- 3.4	- 8.8	—	- 2.4	—		
( $V_{OL} = 0.4$ Vdc) ( $V_{OL} = 0.5$ Vdc) ( $V_{OL} = 1.5$ Vdc)	Sink	$I_{OL}$	5.0	0.64	—	0.51	0.88	—	0.36	—	mAdc
			10	1.6	—	1.3	2.25	—	0.9	—	
			15	4.2	—	3.4	8.8	—	2.4	—	

#Data labelled "Typ" is not to be used for design purposes but is intended as an indication of the IC's potential performance.

**ELECTRICAL CHARACTERISTICS — continued** (Voltages Referenced to V<sub>SS</sub>)

Characteristic	Symbol	V <sub>DD</sub> Vdc	-55°C		25°C			125°C		Unit
			Min	Max	Min	Typ #	Max	Min	Max	
Input Current, RST	I <sub>in</sub>	15	25	—	—	150	—	—	250	μAdc
Input Current	I <sub>in</sub>	15	—	± 0.1	—	± 0.00001	± 0.1	—	± 1.0	μAdc
Input Capacitance (Data)	C <sub>in</sub>	—	—	—	—	15	—	—	—	pF
Input Capacitance (All Other Inputs)	C <sub>in</sub>	—	—	—	—	5.0	7.5	—	—	pF
Quiescent Current (Per Package) I <sub>out</sub> = 0 μA, V <sub>in</sub> = 0 or V <sub>DD</sub>	I <sub>DD</sub>	5.0	—	5.0	—	0.005	5.0	—	150	μAdc
		10	—	10	—	0.010	10	—	300	
		15	—	20	—	0.015	20	—	600	
**Total Supply Current at an External Load Capacitance (C <sub>L</sub> ) on All Outputs	I <sub>T</sub>	—	I <sub>T</sub> = (1.5 μA/kHz) f + I <sub>DD</sub> I <sub>T</sub> = (3.0 μA/kHz) f + I <sub>DD</sub> I <sub>T</sub> = (4.5 μA/kHz) f + I <sub>DD</sub>						μAdc	

\*\*The formulas given are for the typical characteristics only at 25°C.

#Data labelled "Typ" is not to be used for design purposes but is intended as an indication of the IC's potential performance.

**SWITCHING CHARACTERISTICS\*** (T<sub>A</sub> = 25°C; t<sub>r</sub> = t<sub>f</sub> = 20 ns for X and I inputs; C<sub>L</sub> = 50 pF for JMP, X1, RR, Flag O, Flag F; C<sub>L</sub> = 130 pF + 1 TTL load for Data and Write.)

Characteristic	Symbol	V <sub>DD</sub> Vdc	All Types			Unit
			Min	Typ #	Max	
Propagation Delay Time, X1 to RR  X1 to Flag F, Flag O, RTN, JMP  X1 to Write  X1 to Data  RST to RR  RST to X1  RST to Flag F, Flag O, RTN, JMP  RST to Write, Data	t <sub>PLH</sub> , t <sub>PHL</sub>	5.0	—	250	500	ns
		10	—	125	250	
		15	—	100	200	
		5.0	—	200	400	
		10	—	100	200	
		15	—	85	170	
		5.0	—	225	450	
		10	—	125	250	
		15	—	100	200	
RST to RR		5.0	—	250	500	
		10	—	125	250	
		15	—	100	200	
RST to X1		5.0	—	450	Note 1	
		10	—	200		
		15	—	150		
RST to Flag F, Flag O, RTN, JMP		5.0	—	400	800	
		10	—	200	400	
		15	—	150	300	
RST to Write, Data		5.0	—	450	900	
		10	—	225	450	
		15	—	175	350	
Clock Pulse Width, X1	t <sub>W(c)</sub>	5.0	400	200	—	ns
		10	200	100	—	
		15	180	90	—	
Rent Pulse Width, RST	t <sub>W(R)</sub>	5.0	500	250	—	ns
		10	250	125	—	
		15	200	100	—	
Setup Time — Instruction  Data	t <sub>su(I)</sub>	5.0	400	200	—	ns
		10	250	125	—	
		15	180	90	—	
	t <sub>su(D)</sub>	5.0	200	100	—	
		10	100	50	—	
		15	80	40	—	
Hold Time — Instruction  Data	t <sub>h(I)</sub>	5.0	100	0	—	ns
		10	50	0	—	
		15	50	0	—	
	t <sub>h(D)</sub>	5.0	200	100	—	
		10	100	50	—	
		15	100	50	—	

NOTE 1. Maximum Reset Delay may extend to one-half clock period.

#Data labelled "Typ" is not to be used for design purposes but is intended as an indication of the IC's potential performance.

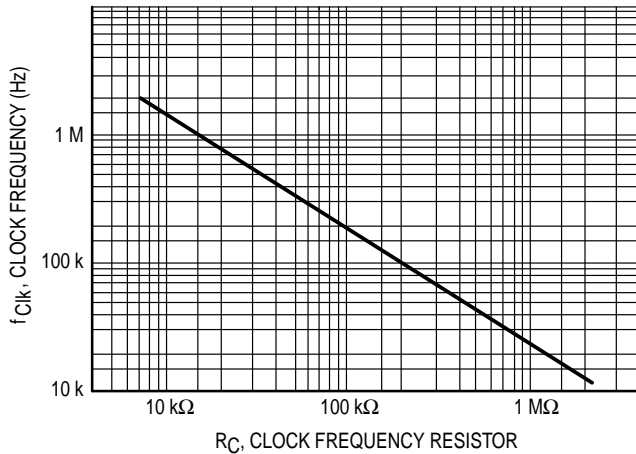
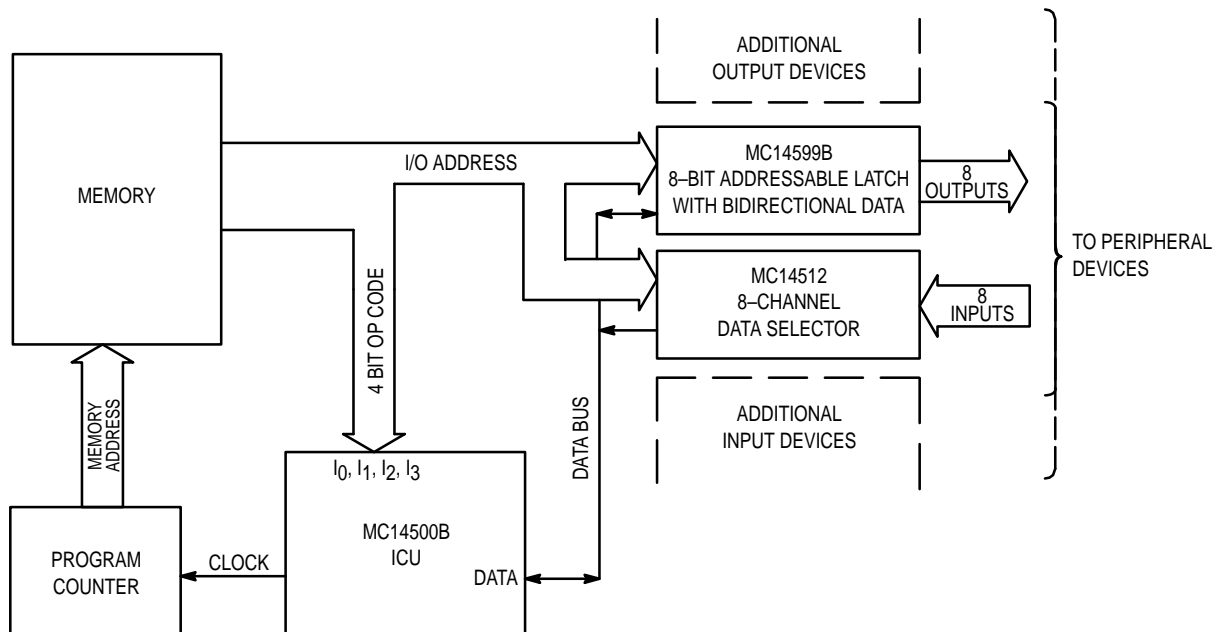

**Figure 1. Typical Clock Frequency versus Resistor ( $R_C$ )**

Pin No.	Function	Symbols
1	Chip Reset	RST
2	Write Pulse	Write
3	Data In/Out	Data
4	MSB Instruction Word	$I_3$
5	Bit 2 Instruction Word	$I_2$
6	Bit 1 Instruction Word	$I_1$
7	LSB Instruction Word	$I_0$
8	Negative Supply (Ground)	$V_{SS}$
9	Flag on NOP F	Flag F
10	Flag on NOP O	Flag O
11	Subroutine Return Flag	RTN
12	Jump Instruction Flag	JMP
13	Oscillator Input	X2
14	Oscillator Output	X1
15	Result Register	RR
16	Positive Supply	$V_{DD}$

**Table 1. MC14500B Instruction Set**

Instruction Code	Mnemonic	Action
0 0000	NOPO	No change in registers. $RR \rightarrow RR$ , Flag O $\rightarrow$
1 0001	LD	Load result register. Data $\rightarrow$ RR
2 0010	LDC	Load complement. $\overline{\text{Data}} \rightarrow$ RR
3 0011	AND	Logical AND. $RR \bullet \text{Data} \rightarrow$ RR
4 0100	ANDC	Logical AND complement. $RR \bullet \overline{\text{Data}} \rightarrow$ RR
5 0101	OR	Logical OR. $RR + \text{Data} \rightarrow$ RR
6 0110	ORC	Logical OR complement. $RR + \overline{\text{Data}} \rightarrow$ RR
7 0111	XNOR	Exclusive NOR. If $RR = \text{Data}$ , $RR \rightarrow 1$
8 1000	STO	Store. $RR \rightarrow$ Data Pin, Write $\rightarrow$
9 1001	STOC	Store complement. $\overline{RR} \rightarrow$ Data Pin, Write $\rightarrow$
A 1010	IEN	Input enable. Data $\rightarrow$ IEN Register
B 1011	OEN	Output enable. Data $\rightarrow$ OEN Register
C 1100	JMP	Jump. JMP Flag $\rightarrow$
D 1101	RTN	Return. RTN Flag $\rightarrow$ and skip next instruction
E 1110	SKZ	Skip next instruction if $RR = 0$
F 1111	NOPF	No change in registers. $RR \rightarrow$ RR, Flag F $\rightarrow$



**Figure 2. Outline of a Typical Organization for a MC14500B-Based System**

### TIMING WAVEFORMS

**Instructions NOPO, NOPF**  
**RR, IEN, OEN remain unaffected**

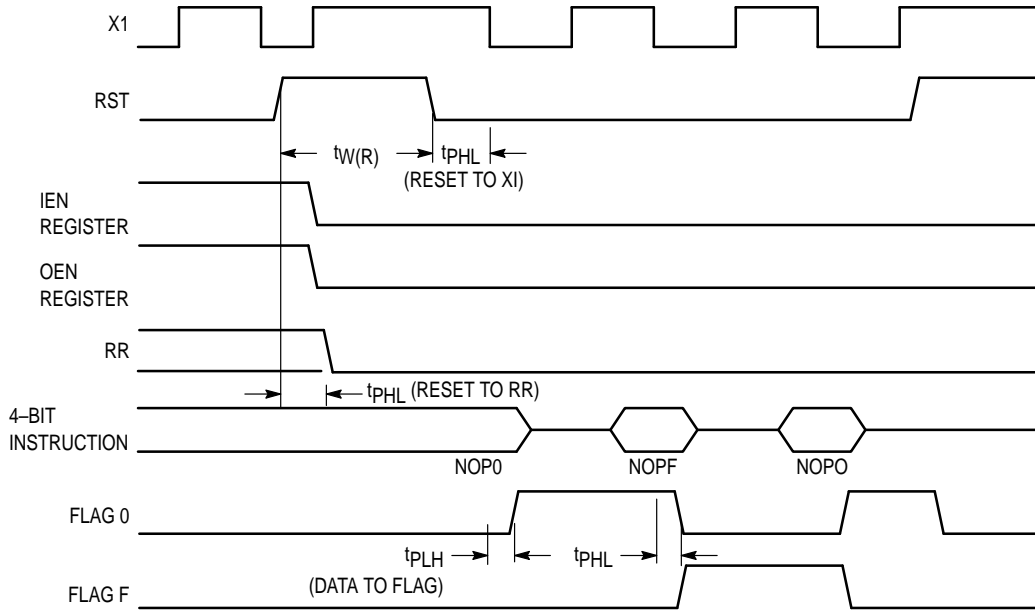

**Instructions SKZ, JMP, RTN**  
**RR, IEN, OEN remain unaffected**

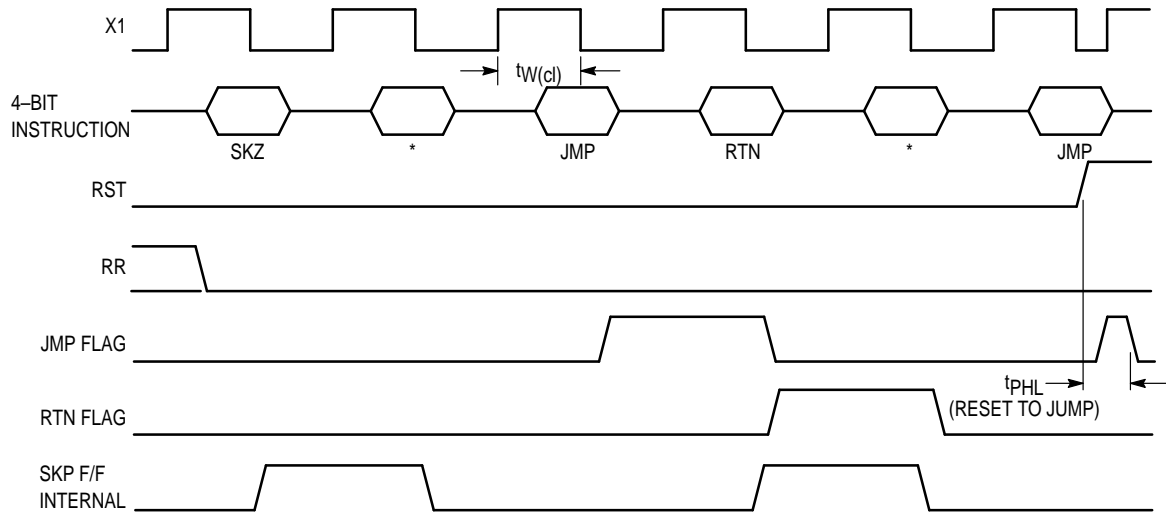

\* Instructions Ignored.

## TIMING WAVEFORMS

### Instructions STO, STOC, OEN

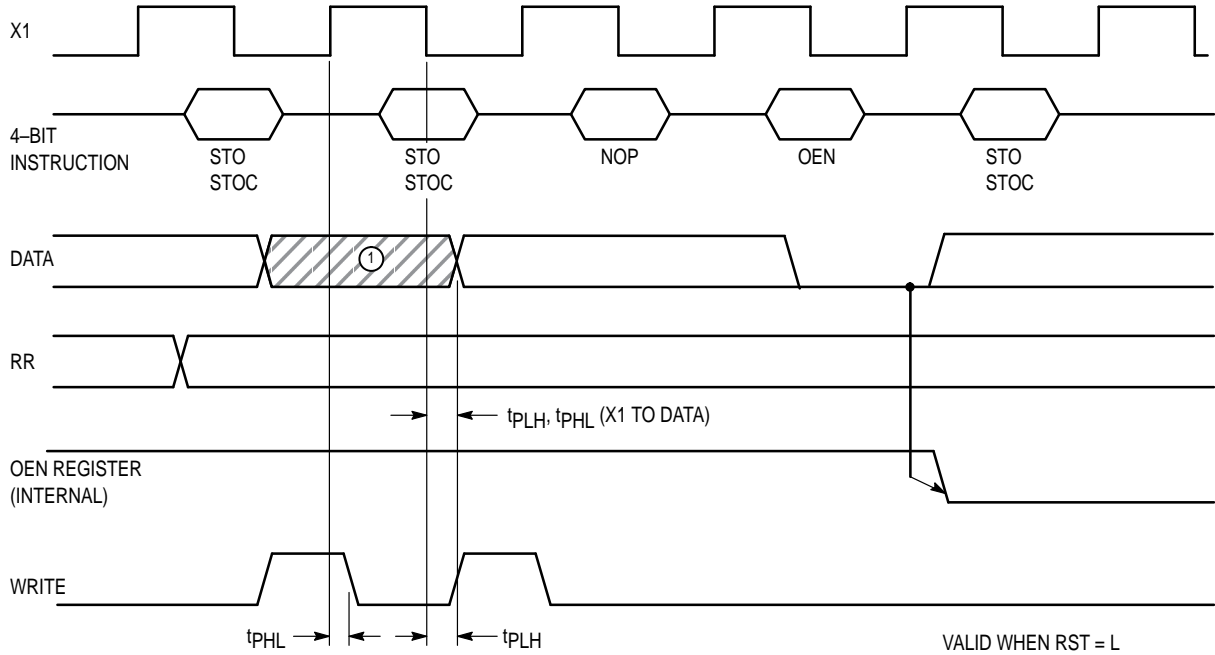

NOTE 1. Valid output data.

### Instructions LD, LDC, AND, ANDC, OR, ORC, XNOR, IEN

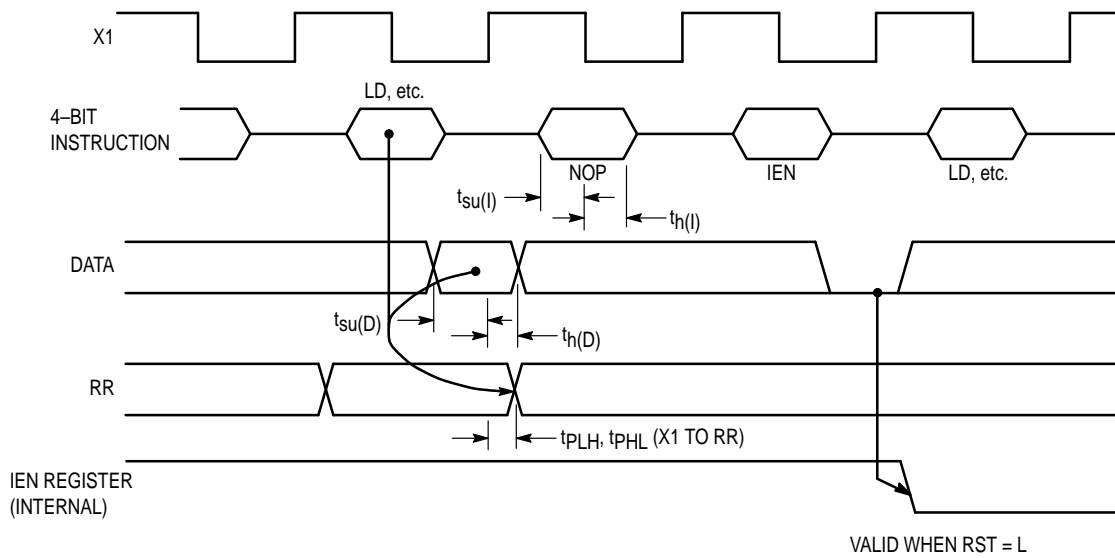

VALID WHEN RST = L

## OUTLINE DIMENSIONS

### L SUFFIX CERAMIC DIP PACKAGE CASE 620-10 ISSUE V

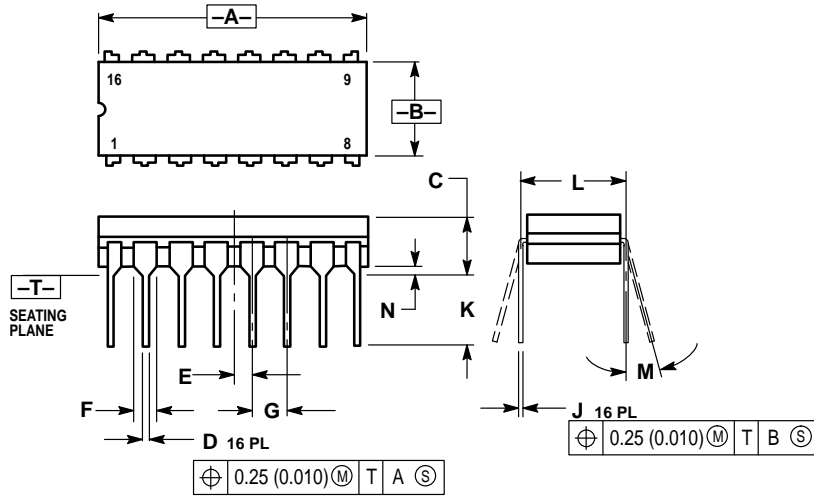

**NOTES:**

1. DIMENSIONING AND TOLERANCING PER ANSI Y14.5M, 1982.
2. CONTROLLING DIMENSION: INCH.
3. DIMENSION L TO CENTER OF LEAD WHEN FORMED PARALLEL.
4. DIMENSION F MAY NARROW TO 0.76 (0.030) WHERE THE LEAD ENTERS THE CERAMIC BODY.

DIM	INCHES		MILLIMETERS	
	MIN	MAX	MIN	MAX
A	0.750	0.785	19.05	19.93
B	0.240	0.295	6.10	7.49
C	—	0.200	—	5.08
D	0.015	0.020	0.39	0.50
E	0.050 BSC		1.27 BSC	
F	0.055	0.065	1.40	1.65
G	0.100 BSC		2.54 BSC	
H	0.008	0.015	0.21	0.38
K	0.125	0.170	3.18	4.31
L	0.300 BSC		7.62 BSC	
M	0°	15°	0°	15°
N	0.020	0.040	0.51	1.01

### P SUFFIX PLASTIC DIP PACKAGE CASE 648-08 ISSUE R

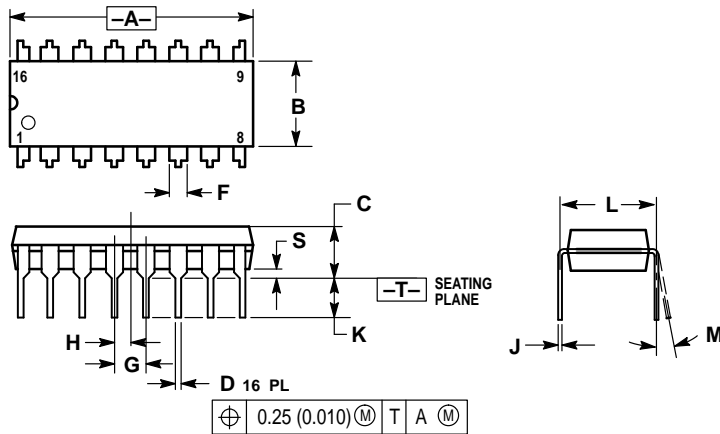

**NOTES:**

1. DIMENSIONING AND TOLERANCING PER ANSI Y14.5M, 1982.
2. CONTROLLING DIMENSION: INCH.
3. DIMENSION L TO CENTER OF LEADS WHEN FORMED PARALLEL.
4. DIMENSION B DOES NOT INCLUDE MOLD FLASH.
5. ROUNDED CORNERS OPTIONAL.

DIM	INCHES		MILLIMETERS	
	MIN	MAX	MIN	MAX
A	0.740	0.770	18.80	19.55
B	0.250	0.270	6.35	6.85
C	0.145	0.175	3.69	4.44
D	0.015	0.021	0.39	0.53
F	0.040	0.70	1.02	1.77
G	0.100 BSC		2.54 BSC	
H	0.050 BSC		1.27 BSC	
J	0.008	0.015	0.21	0.38
K	0.110	0.130	2.80	3.30
L	0.295	0.305	7.50	7.74
M	0°	10°	0°	10°
S	0.020	0.040	0.51	1.01

## OUTLINE DIMENSIONS

### DW SUFFIX PLASTIC SOIC PACKAGE CASE 751G-02 ISSUE A

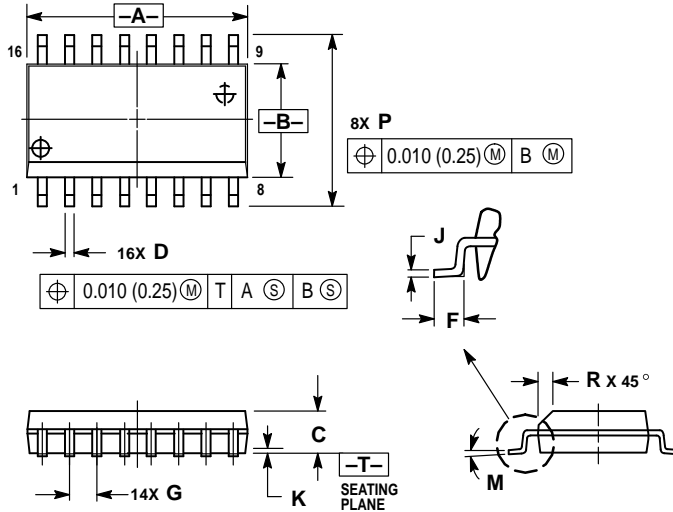

**NOTES:**

1. DIMENSIONING AND TOLERANCING PER ANSI Y14.5M, 1982.
2. CONTROLLING DIMENSION: MILLIMETER.
3. DIMENSIONS A AND B DO NOT INCLUDE MOLD PROTRUSION.
4. MAXIMUM MOLD PROTRUSION 0.15 (0.006) PER SIDE.
5. DIMENSION D DOES NOT INCLUDE DAMBAR PROTRUSION. ALLOWABLE DAMBAR PROTRUSION SHALL BE 0.13 (0.005) TOTAL IN EXCESS OF D DIMENSION AT MAXIMUM MATERIAL CONDITION.

DIM	MILLIMETERS		INCHES	
	MIN	MAX	MIN	MAX
A	10.15	10.45	0.400	0.411
B	7.40	7.60	0.292	0.299
C	2.35	2.65	0.093	0.104
D	0.35	0.49	0.014	0.019
F	0.50	0.90	0.020	0.035
G	1.27 BSC		0.050 BSC	
J	0.25	0.32	0.010	0.012
K	0.10	0.25	0.004	0.009
M	0°	7°	0°	7°
P	10.05	10.55	0.395	0.415
R	0.25	0.75	0.010	0.029

Motorola reserves the right to make changes without further notice to any products herein. Motorola makes no warranty, representation or guarantee regarding the suitability of its products for any particular purpose, nor does Motorola assume any liability arising out of the application or use of any product or circuit, and specifically disclaims any and all liability, including without limitation consequential or incidental damages. "Typical" parameters which may be provided in Motorola data sheets and/or specifications can and do vary in different applications and actual performance may vary over time. All operating parameters, including "Typicals" must be validated for each customer application by customer's technical experts. Motorola does not convey any license under its patent rights nor the rights of others. Motorola products are not designed, intended, or authorized for use as components in systems intended for surgical implant into the body, or other applications intended to support or sustain life, or for any other application in which the failure of the Motorola product could create a situation where personal injury or death may occur. Should Buyer purchase or use Motorola products for any such unintended or unauthorized application, Buyer shall indemnify and hold Motorola and its officers, employees, subsidiaries, affiliates, and distributors harmless against all claims, costs, damages, and expenses, and reasonable attorney fees arising out of, directly or indirectly, any claim of personal injury or death associated with such unintended or unauthorized use, even if such claim alleges that Motorola was negligent regarding the design or manufacture of the part. Motorola and  are registered trademarks of Motorola, Inc. Motorola, Inc. is an Equal Opportunity/Affirmative Action Employer.

**How to reach us:**

**USA/EUROPE/Locations Not Listed:** Motorola Literature Distribution;  
P.O. Box 20912; Phoenix, Arizona 85036. 1-800-441-2447 or 602-303-5454

**MFAX:** RMFAX0@email.sps.mot.com - TOUCHTONE 602-244-6609  
**INTERNET:** <http://Design-NET.com>

**JAPAN:** Nippon Motorola Ltd.; Tatsumi-SPD-JLDC, 6F Seibu-Butsuryu-Center,  
3-14-2 Tatsumi Koto-Ku, Tokyo 135, Japan. 03-81-3521-8315

**ASIA/PACIFIC:** Motorola Semiconductors H.K. Ltd.; 8B Tai Ping Industrial Park,  
51 Ting Kok Road, Tai Po, N.T., Hong Kong. 852-26629298