



MOTOROLA

MC3405

Dual Operational Amplifier and Dual Comparator

The MC3405 contains two differential-input operational amplifiers and two comparators, each set capable of single supply operation. This operational amplifier-comparator circuit fulfills its applications as a general purpose product for automotive and consumer circuits as well as an industrial building block.

The MC3405 is specified over the commercial operating temperature range of 0° to +70°C.

- Operational Amplifier Equivalent in Performance to MC3403
- Comparator Similar in Performance to LM339
- Single Supply Operation: 3.0 V to 36 V
- Split Supply Operation: ±1.5 V to ±18 V
- Low Supply Current Drain
- Operational Amplifier is Internally Frequency Compensated
- Comparator TTL and CMOS Compatible

DUAL OPERATIONAL AMPLIFIER / DUAL VOLTAGE COMPARATOR

SEMICONDUCTOR TECHNICAL DATA

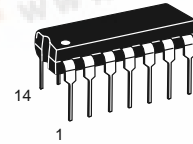

P SUFFIX
PLASTIC PACKAGE
CASE 646

PIN CONNECTIONS

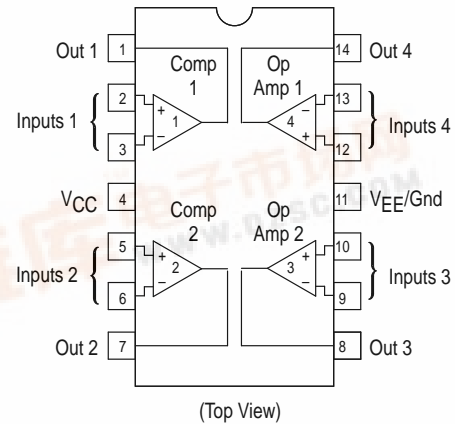

Single Supply

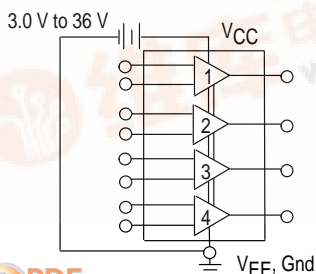

Split Supplies

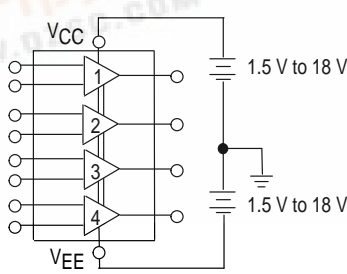

ORDERING INFORMATION

Device	Operating Temperature Range	Package
MC3405P	T _A = 0° to +70°C	Plastic DIP



MC3405

OPERATIONAL AMPLIFIER SECTION

MAXIMUM RATINGS

Rating	Symbol	Value	Unit
Power Supply Voltage – Single Supply Split Supplies	V_{CC} V_{CC}, V_{EE}	36 ± 18	Vdc
Input Differential Voltage Range	V_{IDR}	± 36	Vdc
Input Common Mode Voltage Range	V_{ICR}	± 18	Vdc
Operating Ambient Temperature Range	T_A	0 to +70	°C
Storage Temperature Range	T_{stg}	-55 to +125	°C
Operating Junction Temperature Range	T_J	150	°C

ELECTRICAL CHARACTERISTICS ($V_{CC} = 5.0$ V, $V_{EE} = \text{Gnd}$, $T_A = 25^\circ\text{C}$, unless otherwise noted.)

Characteristic	Symbol	Min	Typ	Max	Unit
Input Offset Voltage	V_{IO}	–	2.0	10	mV
Input Offset Current	I_{IO}	–	30	50	nA
Input Bias Current	I_{IB}	–	-200	-500	nA
Large-Signal, Open Loop Voltage Gain ($R_L = 2.0$ k Ω)	A_{VOL}	20	200	–	V/mV
Power Supply Rejection	PSR	–	–	150	$\mu\text{V/V}$
Output Voltage Range (Note 1) ($R_L = 10$ k Ω , $V_{CC} = 5.0$ V) ($R_L = 10$ k Ω , 5.0 V $\leq V_{CC} \leq 30$ V)	V_{OR}	3.3 $V_{CC}-2.0$	3.5 $V_{CC}-1.7$	– –	V_{pp}
Power Supply Current (Notes 2 and 3)	I_{CC}	–	2.5	7.0	mA
Channel Separation, $f = 1.0$ kHz to 20 kHz (Input Referenced)	–	–	-120	–	dB

ELECTRICAL CHARACTERISTICS ($V_{CC} = +15$ V, $V_{EE} = -15$ V, $T_A = 25^\circ\text{C}$, unless otherwise noted.)

Characteristic	Symbol	Min	Typ	Max	Unit
Input Offset Voltage ($T_A = T_{low} + T_{high}$) (Note 4)	V_{IO}	– –	2.0 –	10 12	mV
Average Temperature Coefficient of Input Offset Voltage	$\Delta V_{IO}/\Delta T$	–	15	–	$\mu\text{V}/^\circ\text{C}$
Input Offset Current ($T_A = T_{low}$ to T_{high}) (Note 4)	I_{IO}	– –	– –	50 200	nA
Input Bias Current ($T_A = T_{low}$ to T_{high}) (Note 4)	I_{IB}	– –	-200 –	-500 -800	nA
Input Common Mode Voltage Range	V_{ICR}	+13 $-V_{EE}$	–	–	Vdc
Large Signal, Open Loop Voltage Gain ($V_O = \pm 10$ V, $R_L = 2.0$ k Ω) ($T_A = T_{low}$ to T_{high}) (Note 4)	A_{VOL}	20 15	200 100	– –	V/mV
Common Mode Rejection	CMR	70	90	–	dB
Power Supply Rejection Ratio	PSRR	–	30	150	$\mu\text{V/V}$
Output Voltage ($R_L = 10$ k Ω) ($R_L = 2.0$ k Ω) ($R_L = 2.0$ k Ω , $T_A = T_{low}$ to T_{high}) (Note 4)	V_O	± 12 ± 10 ± 10	± 13.5 ± 13 –	– – –	Vdc
Output Short Circuit Current	I_{SC}	± 10	± 20	± 45	mA
Power Supply Current (Notes 2 and 3)	I_{CC}, I_{EE}	–	2.8	7.0	mA
Phase Margin	ϕ_m	–	60	–	Degrees
Small-Signal Bandwidth ($A_V = 1$, $R_L = 10$ k Ω , $V_O = 50$ mV)	BW	–	1.0	–	MHz

- NOTES:**
- Output will swing to ground.
 - Not to exceed maximum package power dissipation.
 - For operational amplifier and comparator.
 - $T_{low} = 0^\circ\text{C}$, $T_{high} = +70^\circ\text{C}$

MC3405

ELECTRICAL CHARACTERISTICS ($V_{CC} = +15\text{ V}$, $V_{EE} = -15\text{ V}$, $T_A = 25^\circ\text{C}$, unless otherwise noted.)

Characteristic	Symbol	Min	Typ	Max	Unit
Power Bandwidth ($A_V = 1$, $R_L = 2.0\text{ k}\Omega$, $V_O = 20\text{ V}_{pp}$, THD = 5%)	BWp	–	9.0	–	kHz
Rise Time/Fall Time	t_{TLH} , t_{THL}	–	0.35	–	μs
Overshoot ($A_V = 1$, $R_L = 10\text{ k}\Omega$, $V_O = 50\text{ mV}$)	os	–	20	–	%
Slew Rate	SR	–	0.6	–	$\text{V}/\mu\text{s}$

COMPARATOR SECTION

MAXIMUM RATINGS

Rating	Symbol	Value	Unit
Power Supply Voltage – Single Supply Split Supplies	V_{CC} V_{CC} , V_{EE}	36 ± 18	Vdc
Input Differential Voltage Range	V_{IDR}	± 36	Vdc
Input Common Mode Voltage Range	V_{ICR}	–0.3 to +36	Vdc
Sink Current	I_{Sink}	20	mA
Operating Ambient Temperature Range	T_A	0 to +70	$^\circ\text{C}$
Storage Temperature Range	T_{stg}	–55 to +125	$^\circ\text{C}$
Operating Junction Temperature Range	T_J	150	$^\circ\text{C}$

ELECTRICAL CHARACTERISTICS ($V_{CC} = 5.0\text{ V}$, $V_{EE} = \text{Gnd}$, $T_A = 25^\circ\text{C}$, unless otherwise noted.)

Characteristic	Symbol	Min	Typ	Max	Unit
Input Offset Voltage ($T_A = T_{low}$ to T_{high}) (Notes 1 and 2)	V_{IO}	– –	2.0 –	10 12	mV
Average Temperature Coefficient of Input Offset Voltage	$\Delta V_{IO}/\Delta T$	–	15	–	$\mu\text{V}/^\circ\text{C}$
Input Offset Current ($T_A = T_{low}$ to T_{high}) (Note 1)	I_{IO}	– –	50 –	100 200	nA
Input Bias Current ($T_A = T_{low}$ to T_{high}) (Note 1)	I_{IB}	– –	–125 –	–500 –800	nA
Input Common Mode Voltage Range ($T_A = T_{low}$ to T_{high}) (Note 1)	V_{ICR}	0 0	$V_{CC} - 1.5$ $V_{CC} - 1.7$	$V_{CC} - 1.7$ $V_{CC} - 2.0$	Vpp
Input Differential Voltage (All $V_{in} \geq 0\text{ Vdc}$)	V_{ID}	–	–	36	V
Large-Signal, Open Loop Voltage Gain ($R_L = 15\text{ k}\Omega$)	A_{VOL}	–	200	–	V/mV
Output Sink Current ($-V_{in} \geq 1.0\text{ Vdc}$, $+V_{in} = 0$, $V_O \leq 1.5\text{ V}$)	I_{Sink}	6.0	16	–	mA
Low Level Output Voltage ($+V_{in} = 0\text{ V}$, $-V_{in} = 1.0\text{ V}$, $I_{Sink} = 4.0\text{ mA}$) ($T_A = T_{low}$ to T_{high}) (Note 1)	V_{OL}	– –	350 –	500 700	μA
Output Leakage Current ($+V_{in} \geq 1.0\text{ Vdc}$, $-V_{in} = 0$, $V_O = 5.0\text{ Vdc}$) ($T_A = T_{low}$ to T_{high}) (Note 1)	I_{OL}	– –	0.1 0.1	1.0 1.0	μA
Large-Signal Response	–	–	300	–	ns
Response Time (Note 3) ($V_{RL} = 5.0\text{ Vdc}$, $R_L = 5.1\text{ k}\Omega$)	–	–	1.3	–	μs

- NOTES:** 1. $T_{low} = 0^\circ\text{C}$, $T_{high} = +70^\circ\text{C}$
 2. $V_O \cong 1.4\text{ V}$, $R_S = 0\ \Omega$ with V_{CC} from 5.0 Vdc to 30 Vdc, and over the input common mode range 0 to $V_{CC} - 1.7\text{ V}$.
 3. The response time specified is for a 100 mV input step with 5.0 mV overdrive. For larger signals 300 ns is typical.

MC3405

Representative Schematic Diagram
(1/2 of Circuit Shown)

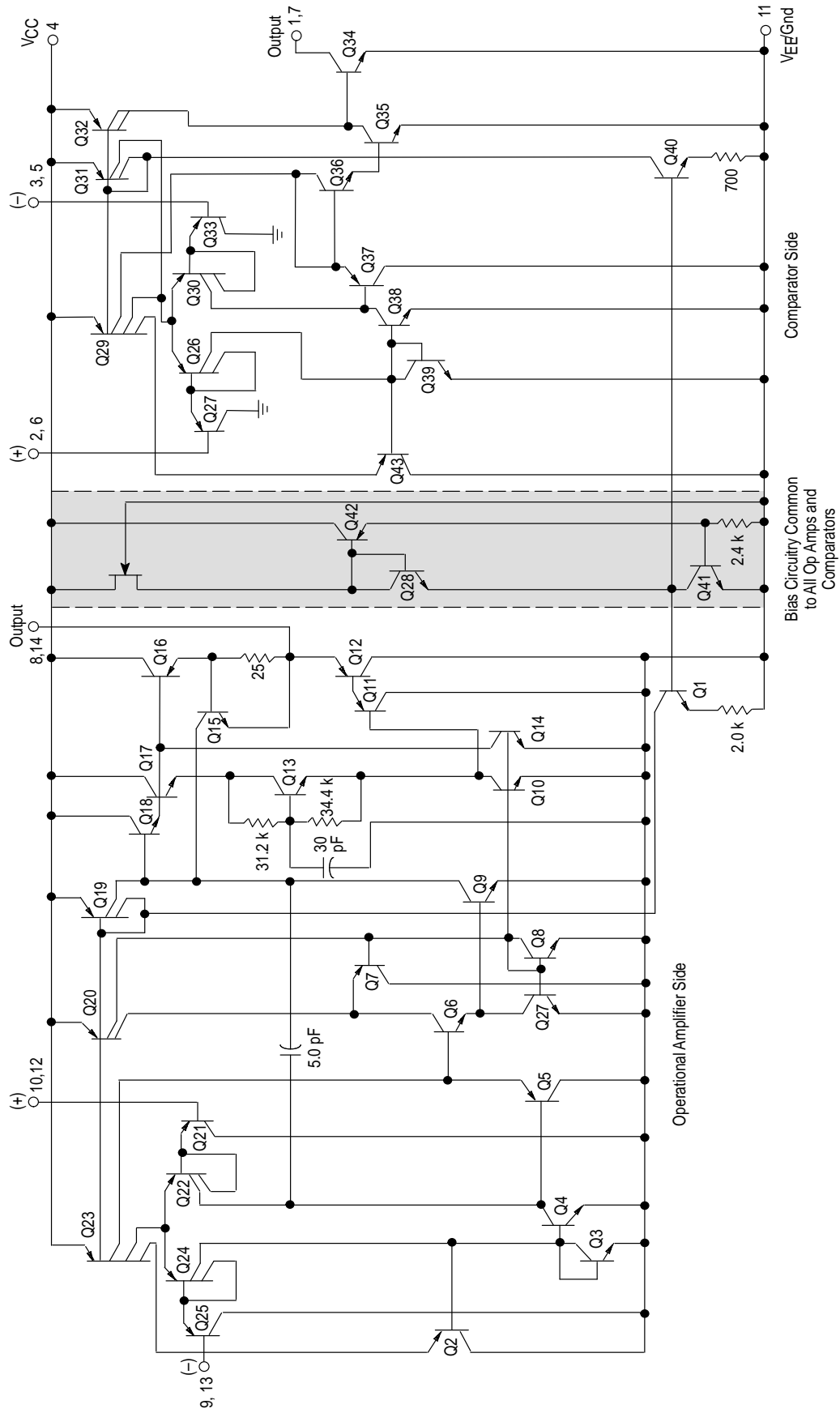

MC3405

OPERATIONAL AMPLIFIER SECTION

Figure 1. Sine Wave Response

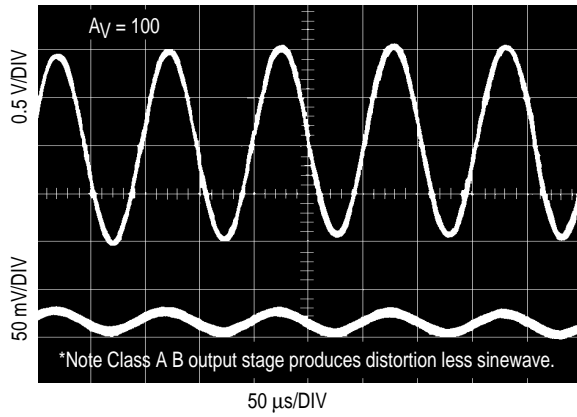

Figure 2. Open Loop Frequency Response

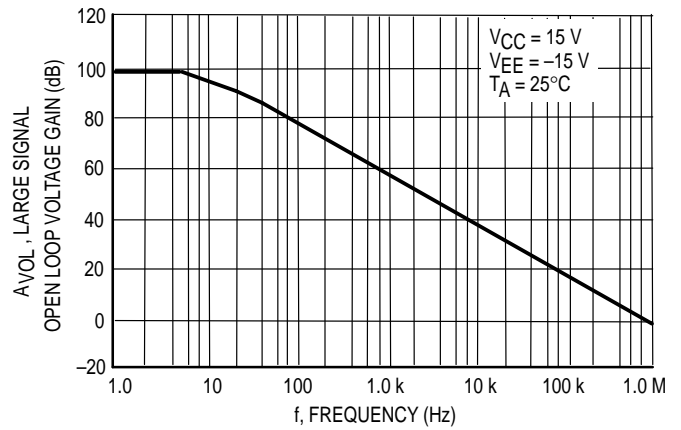

Figure 3. Power Bandwidth

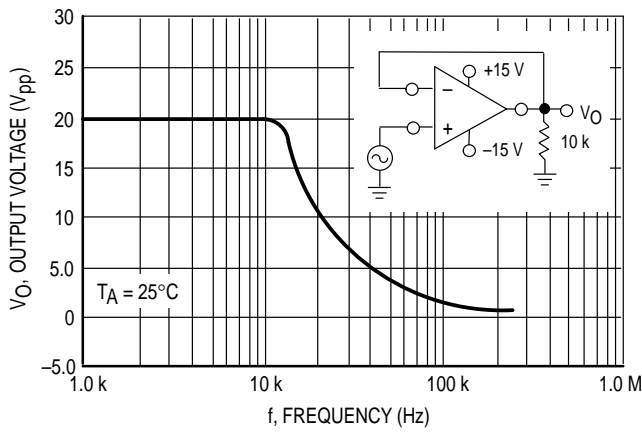

Figure 4. Output Swing versus Supply Voltage

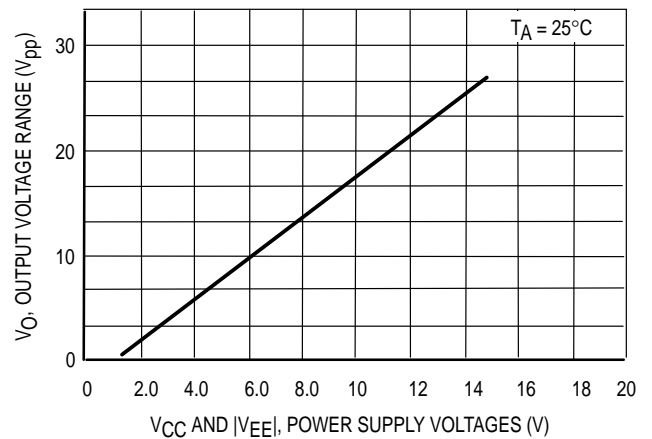

Figure 5. Input Bias Current versus Temperature

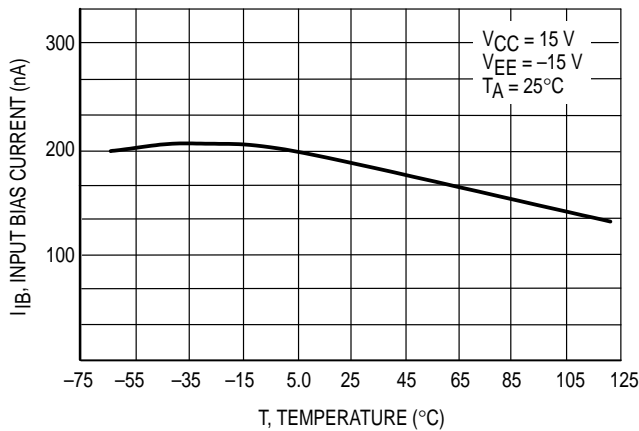
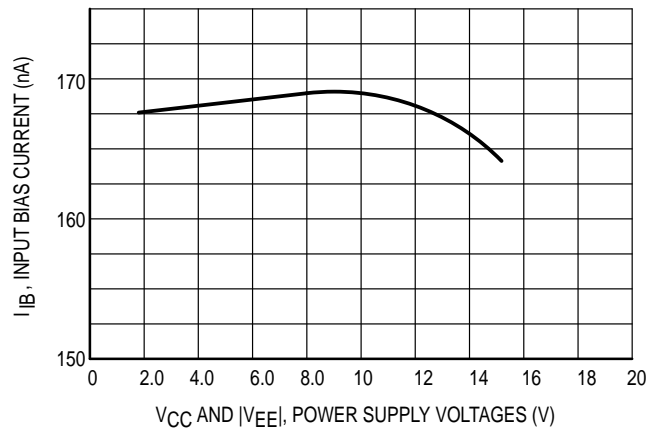

Figure 6. Input Bias Current versus Supply Voltage



MC3405

COMPARATOR SECTION

Figure 7. Normalized Input Offset Voltage

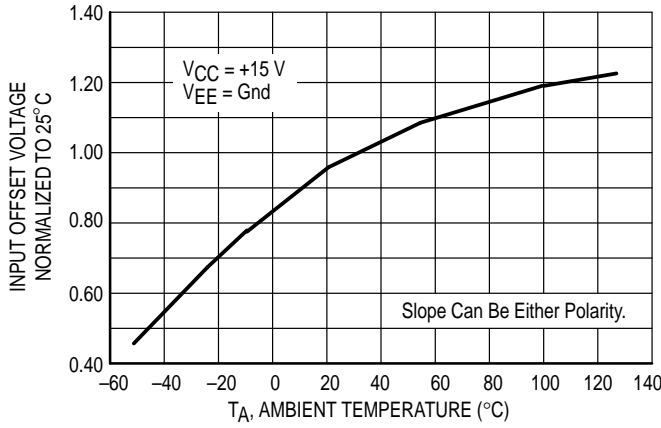

Figure 8. Input Bias Current

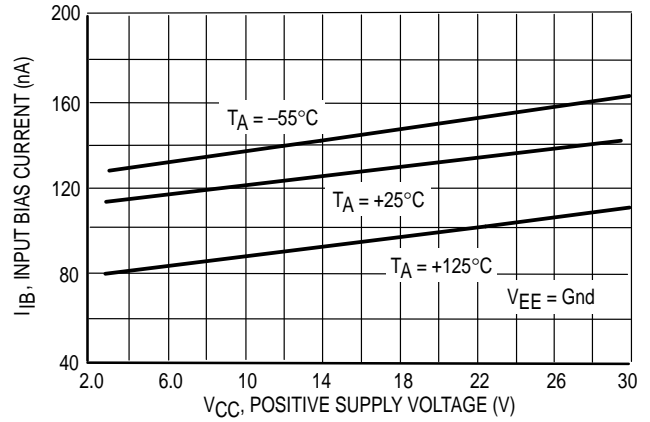

Figure 9. Normalized Input Offset Current

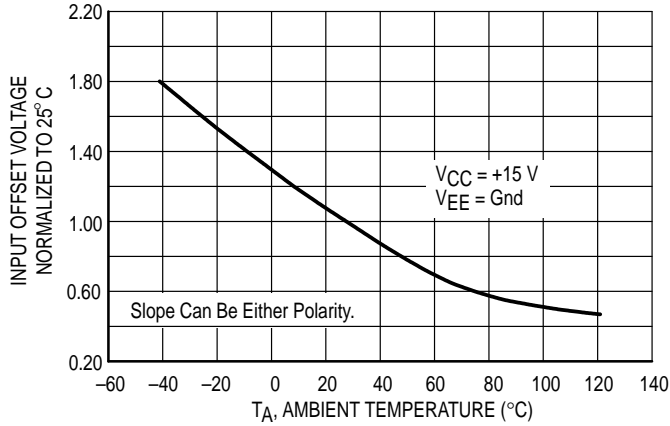

Figure 10. Output Sink Current versus Output Voltage

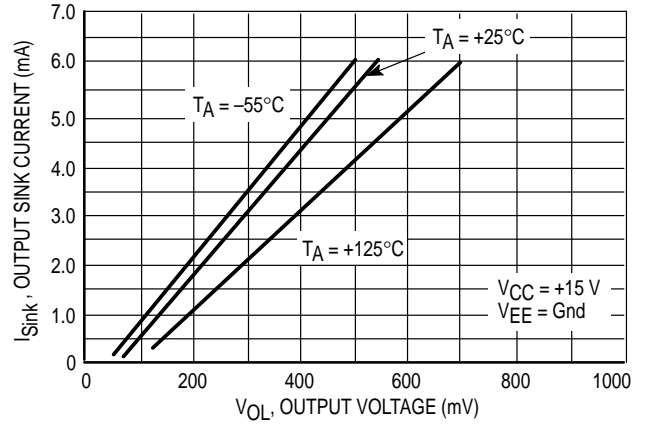
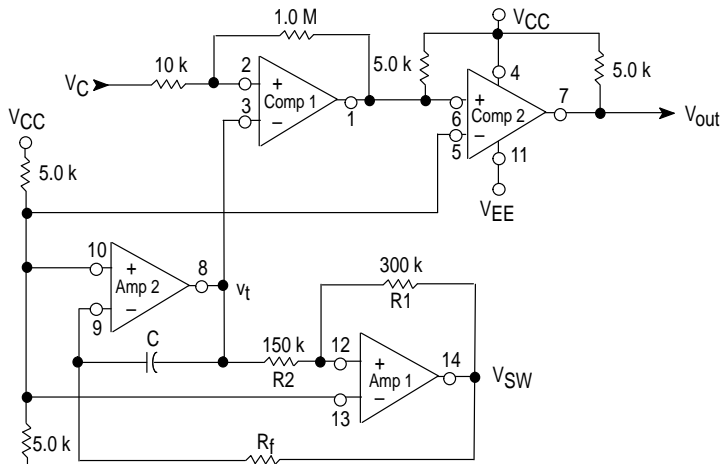

Figure 11. Pulse Width Modulator Schematic and Waveforms



$$V_{TH} = \frac{1}{2} V_S(1 + R_2/R_1) + V_{EE} \quad V_S = V_{CC} - V_{EE}$$

$$V_{TL} = \frac{1}{2} V_S(1 - R_2/R_1) + V_{EE}$$

$$\text{Oscillator Frequency } f = \frac{R_1}{4R_fCR_2}$$

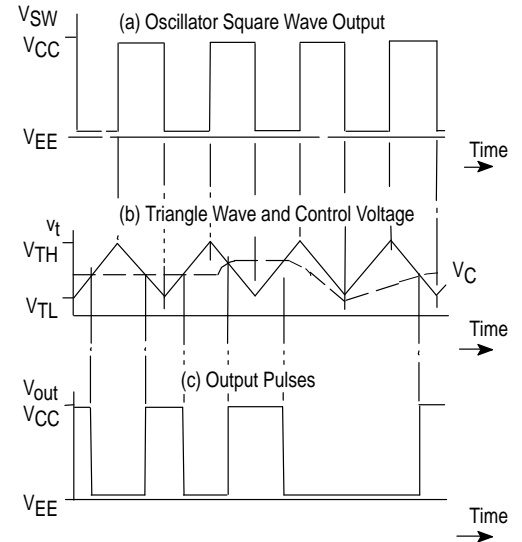

$$\text{Pulse Width} = \left(\frac{1}{f} \right) \left(\frac{V_C - V_{TL}}{V_{TH} - V_{TL}} \right) \text{ when: } V_{TL} < V_C < V_{TH}$$

$$\text{Duty Cycle in \%} = \left(\frac{V_C - V_{TL}}{V_{TH} - V_{TL}} \right) (100)$$

MC3405

Figure 12. Window Comparator

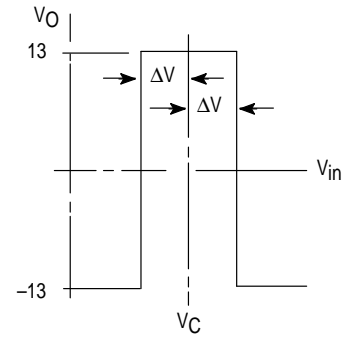
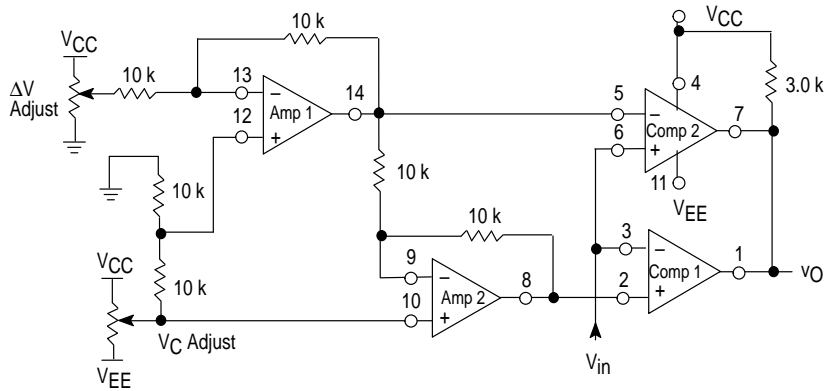

Figure 13. Squelch Circuit for AM or FM

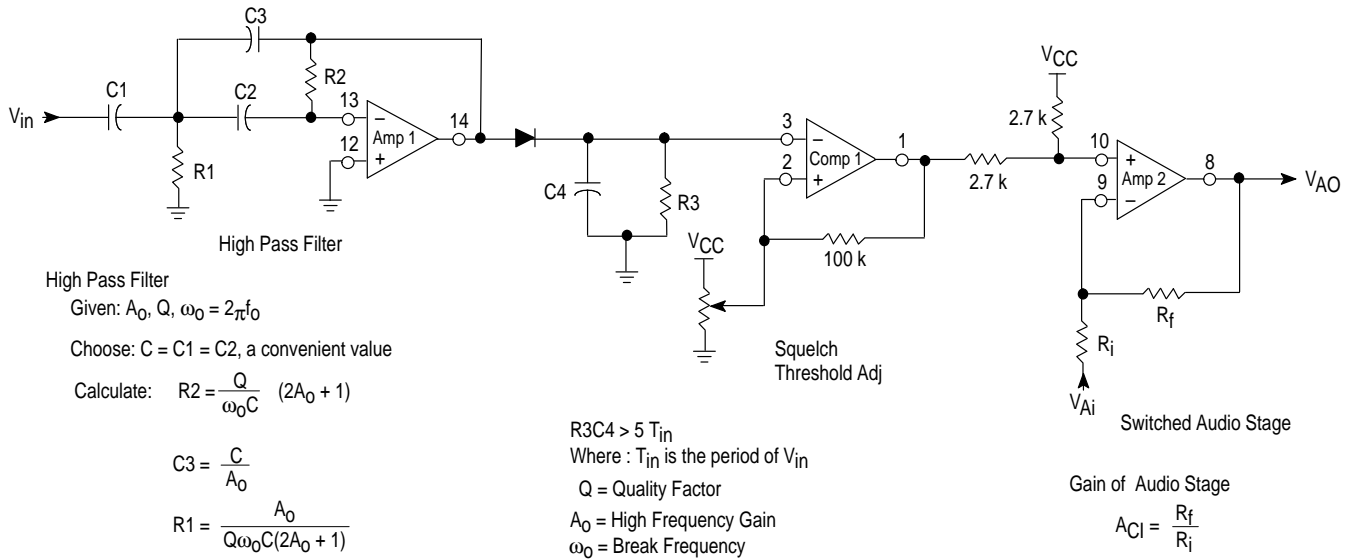
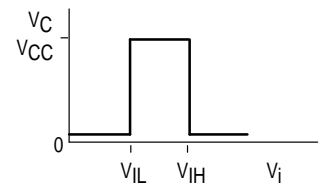
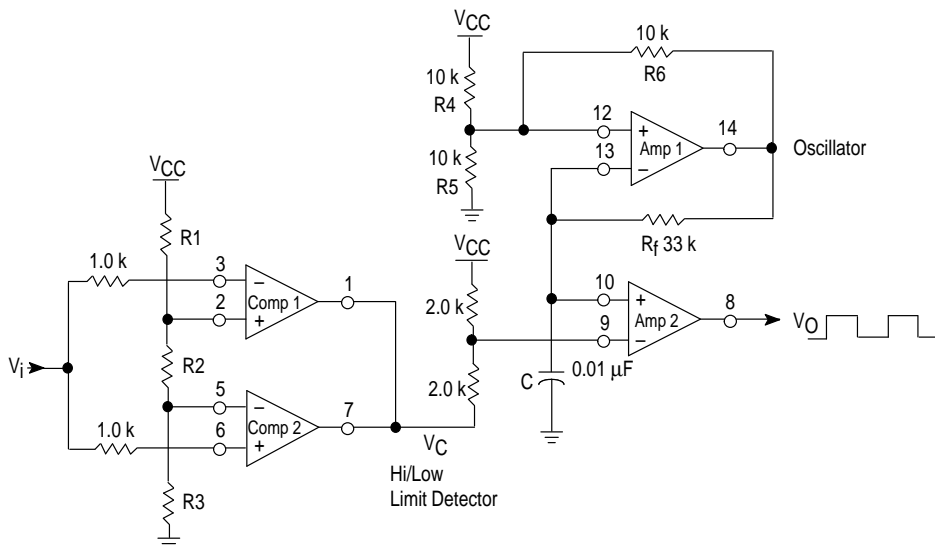

Figure 14. High/Low Limit Alarm



$$V_{IL} = V_{CC} \frac{R3}{R1 + R2 + R3}$$

$$V_{IH} = V_{CC} \frac{R2 + R3}{R1 + R2 + R3}$$

Oscillator

$$f = 0.72/R_f C$$

As shown, $f = 2.2 \text{ kHz}$

V_O will oscillate if $V_{IH} < V_i$ or $V_{IL} > V_i$

V_O will be low if $V_{IL} < V_i < V_{IH}$

MC3405

Figure 15. Zero Crossing Detector with Temperature Sensor

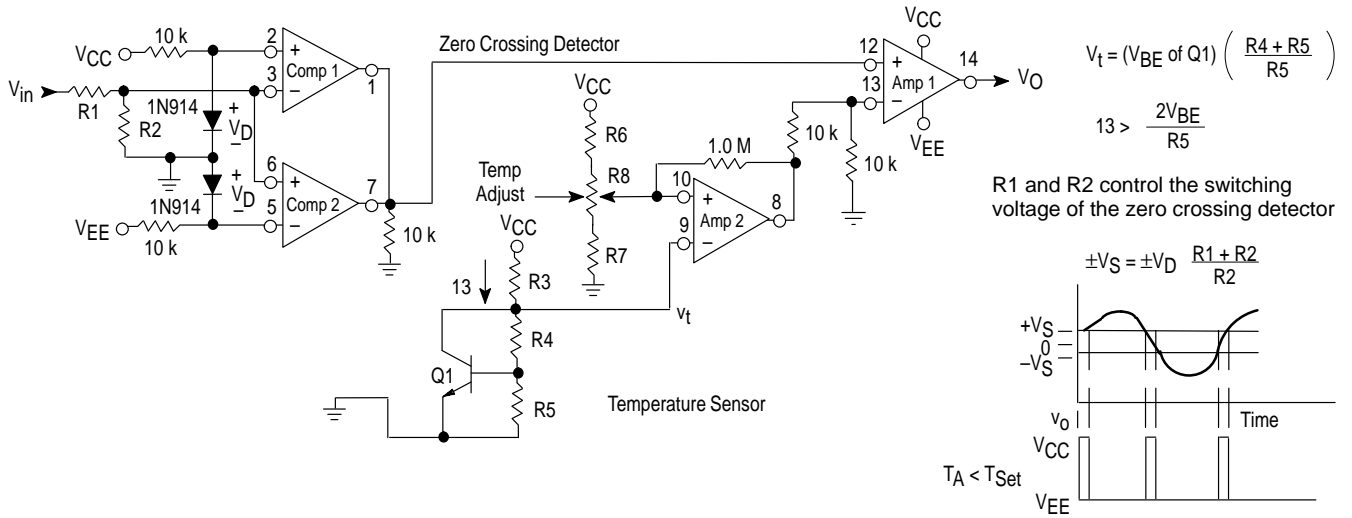
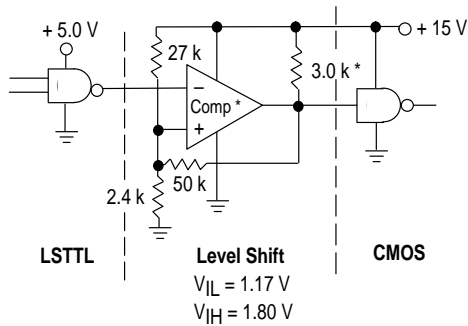
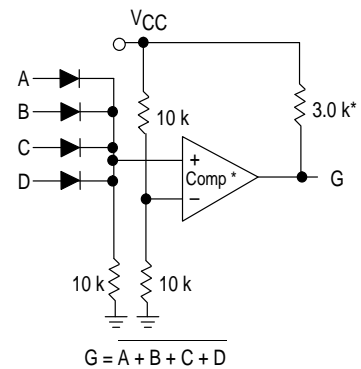

Figure 16. LSTTL to CMOS Interface with Hysteresis



* The same configuration may be used with an op amp if the $3.0k$ resistor is removed.

Figure 17. NOR Gate



* The same configuration may be used with an op amp if the $3.0k$ resistor is removed.

MC3405

OUTLINE DIMENSIONS

P SUFFIX
PLASTIC PACKAGE
CASE 646-06
ISSUE L

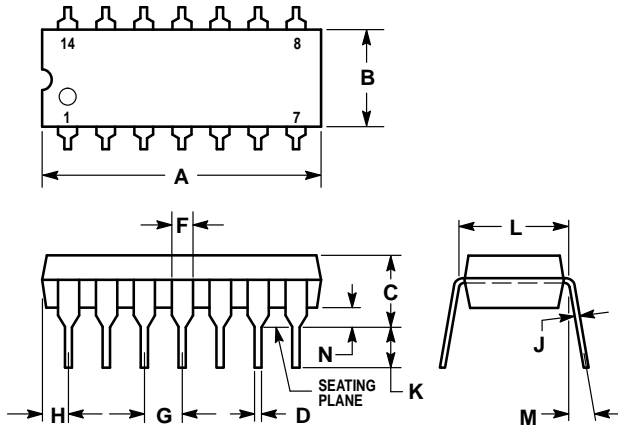

NOTES:

- LEADS WITHIN 0.13 (0.005) RADIUS OF TRUE POSITION AT SEATING PLANE AT MAXIMUM MATERIAL CONDITION.
- DIMENSION L TO CENTER OF LEADS WHEN FORMED PARALLEL.
- DIMENSION B DOES NOT INCLUDE MOLD FLASH.
- ROUNDED CORNERS OPTIONAL.

DIM	INCHES		MILLIMETERS	
	MIN	MAX	MIN	MAX
A	0.715	0.770	18.16	19.56
B	0.240	0.260	6.10	6.60
C	0.145	0.185	3.69	4.69
D	0.015	0.021	0.38	0.53
F	0.040	0.070	1.02	1.78
G	0.100 BSC		2.54 BSC	
H	0.052	0.095	1.32	2.41
J	0.008	0.015	0.20	0.38
K	0.115	0.135	2.92	3.43
L	0.300 BSC		7.62 BSC	
M	0° 10°		0° 10°	
N	0.015	0.039	0.39	1.01

MC3405
NOTES

MC3405
NOTES

MC3405

Motorola reserves the right to make changes without further notice to any products herein. Motorola makes no warranty, representation or guarantee regarding the suitability of its products for any particular purpose, nor does Motorola assume any liability arising out of the application or use of any product or circuit, and specifically disclaims any and all liability, including without limitation consequential or incidental damages. "Typical" parameters which may be provided in Motorola data sheets and/or specifications can and do vary in different applications and actual performance may vary over time. All operating parameters, including "Typicals" must be validated for each customer application by customer's technical experts. Motorola does not convey any license under its patent rights nor the rights of others. Motorola products are not designed, intended, or authorized for use as components in systems intended for surgical implant into the body, or other applications intended to support or sustain life, or for any other application in which the failure of the Motorola product could create a situation where personal injury or death may occur. Should Buyer purchase or use Motorola products for any such unintended or unauthorized application, Buyer shall indemnify and hold Motorola and its officers, employees, subsidiaries, affiliates, and distributors harmless against all claims, costs, damages, and expenses, and reasonable attorney fees arising out of, directly or indirectly, any claim of personal injury or death associated with such unintended or unauthorized use, even if such claim alleges that Motorola was negligent regarding the design or manufacture of the part. Motorola and  are registered trademarks of Motorola, Inc. Motorola, Inc. is an Equal Opportunity/Affirmative Action Employer.

How to reach us:

USA/EUROPE/Locations Not Listed: Motorola Literature Distribution;
P.O. Box 20912; Phoenix, Arizona 85036. 1-800-441-2447 or 602-303-5454

MFAX: RMFAX0@email.sps.mot.com – TOUCHTONE 602-244-6609
INTERNET: <http://Design-NET.com>

JAPAN: Nippon Motorola Ltd.; Tatsumi-SPD-JLDC, 6F Seibu-Butsuryu-Center,
3-14-2 Tatsumi Koto-Ku, Tokyo 135, Japan. 03-81-3521-8315

ASIA/PACIFIC: Motorola Semiconductors H.K. Ltd.; 8B Tai Ping Industrial Park,
51 Ting Kok Road, Tai Po, N.T., Hong Kong. 852-26629298



MOTOROLA