

OPA2662

Dual, Wide Bandwidth OPERATIONAL TRANSCONDUCTANCE AMPLIFIER

FEATURES

- 370MHz BANDWIDTH
- 58mA/ns SLEW RATE
- HIGH OUTPUT CURRENT: $\pm 75\text{mA}$
- 400Mbit/s DATA RATE
- VOLTAGE-CONTROLLED CURRENT SOURCE
- ENABLE/DISABLE FUNCTION

APPLICATIONS

- HEAD DRIVE AMPLIFIER FOR ANALOG/DIGITAL VIDEO TAPES AND DATA RECORDERS
- LED AND LASER DIODE DRIVER
- HIGH CURRENT VIDEO BUFFER OR LINE DRIVER
- RF OUTPUT STAGE DRIVER
- HIGH DENSITY DISK DRIVES

DESCRIPTION

The OPA2662 is a versatile driver device for ultra wide-bandwidth systems, including high-resolution video, RF and IF circuitry, communications and test equipment. The OPA2662 includes two power voltage-controlled current sources, or operational transconductance amplifiers (OTAs), in a 16-pin DIP or SOL-16 package and is specified for the extended industrial temperature range (-40°C to $+85^{\circ}\text{C}$). The output current is zero-for-zero differential input voltage. The OTAs provide a 250MHz large-signal bandwidth, a 58mA/ns slew rate, and each current source delivers up to $\pm 75\text{mA}$ output current.

The transconductance of both OTAs can be adjusted between pin 5 and $-V_{\text{CC}}$ by an external resistor, allowing bandwidth, quiescent current, harmonic distortion and gain trade-offs to be optimized. The output current can be set with a degeneration resistor between the emitter and GND. The current mirror ratio between the collector and emitter currents is fixed to three. Switching stages compatible to logic TTL levels make it possible to turn each OTA separately on within 30ns and off within 200ns at full power.

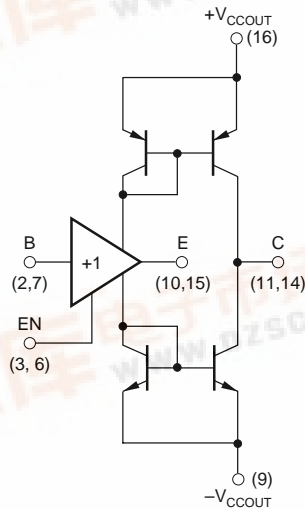

1/2 OPA2662

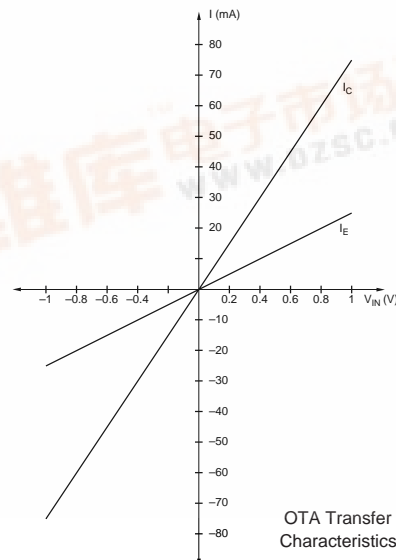

OTA Transfer Characteristics

SPECIFICATIONS

ELECTRICAL

DC-SPECIFICATIONS

At $V_{CC} = \pm 5V$, $R_Q = 750\Omega$, $T_A = +25^\circ C$, and configured as noted under "CONDITIONS".

PARAMETER	CONDITIONS	OPA2662AP, AU			UNITS
		MIN	TYP	MAX	
OTA INPUT OFFSET VOLTAGE Initial vs Temperature vs Supply (tracking) vs Supply (non-tracking) vs Supply (non-tracking) Matching	$R_E = 50k\Omega$, $R_C = 40\Omega$ $V_{CC} = \pm 4.5V$ to $\pm 5.5V$, $R_E = 50k\Omega$, $R_C = 1k\Omega$ $V_{CC} = +4.5V$ to $+5.5V$, $R_E = 50k\Omega$, $R_C = 1k\Omega$ $V_{CC} = -4.5V$ to $-5.5V$, $R_E = 50k\Omega$, $R_C = 1k\Omega$		12 35 27 15 40 2	± 30 ± 7	mV $\mu V/^\circ C$ dB dB dB mV
OTA B-INPUT BIAS CURRENT Initial vs Temperature vs Supply (tracking) vs Supply (non-tracking) vs Supply (non-tracking) Matching	$R_E = 100\Omega$, $R_C = 40\Omega$ $V_{CC} = \pm 4.5V$ to $\pm 5.5V$, $R_E = 50k\Omega$, $R_C = 1k\Omega$ $V_{CC} = +4.5V$ to $+5.5V$, $R_E = 50k\Omega$, $R_C = 1k\Omega$ $V_{CC} = -4.5V$ to $-5.5V$, $R_E = 50k\Omega$, $R_C = 1k\Omega$		1 -5 60 160 40 0.2	-1/+5 ± 1	μA $nA/^\circ C$ nA/V nA/V nA/V μA
OTA C-OUTPUT BIAS CURRENT Initial vs Temperature vs Supply (tracking) vs Supply (non-tracking) vs Supply (non-tracking) Matching	$R_E = 100\Omega$, $R_C = 1k\Omega$ $V_{CC} = \pm 4.5V$ to $\pm 5.5V$ $V_{CC} = +4.5V$ to $+5.5V$ $V_{CC} = -4.5V$ to $-5.5V$		0.5 1.5 72 236 92 0.06	-0.5/+1.5 ± 0.5	mA $\mu A/^\circ C$ $\mu A/V$ $\mu A/V$ $\mu A/V$ mA
B-INPUT IMPEDANCE Impedance	$I_Q = \pm 17mA$		4.5 1.5		M Ω pF
OTA INPUT NOISE Input Noise Voltage Density Output Noise Current Density Signal-to-Noise Ratio	$f = 20kHz$ to $100MHz$ $S/N = 20 \log \cdot (0.7/V_N \cdot \sqrt{5MHz})$		4.4 0.09 97		nV/\sqrt{Hz} nA/\sqrt{Hz} dB
OTA C-RATED OUTPUT Output Voltage Compliance Output Current Output Impedance, r_C	$I_C = \pm 5mA$, $R_E = 100\Omega$, $R_C = 1k\Omega$ $R_C = 40\Omega$, $R_E = 100\Omega$ $V_{IN} = \pm 3V$ $I_Q = \pm 17mA$		± 3.4 ± 75 4.5 6.5		V mA k Ω pF
OTA E-RATED OUTPUT Voltage Output DC Current Output Voltage Gain Output Impedance, r_E	$R_E = 100\Omega$, $R_C = 40\Omega$ $R_E = 100\Omega$, $R_C = 40\Omega$ $V_{IN} = \pm 4V$ $V_{IN} = \pm 2.5V$ $R_E = 100\Omega$ $R_E = 50k\Omega$ $I_Q = \pm 17mA$		± 3.0 ± 25 0.86 0.98 16 2.2		V mA V/V V/V Ω pF
POWER SUPPLY Rated Voltage Derated Performance Positive Quiescent Current for both OTAs ⁽⁴⁾ Positive Quiescent Current for both OTAs ⁽⁴⁾ Quiescent Current Range	$R_E = 50k\Omega$, $R_C = 1k\Omega$ $R_E = 50k\Omega$, $R_C = 40\Omega$ $R_Q = 750\Omega$, $R_E = 50k\Omega$, $R_C = 1k\Omega$, Both Channels Enabled $R_Q = 750\Omega$, $R_E = 50k\Omega$, $R_C = 1k\Omega$, Both Channels Disabled Programmable $R_Q = 3k\Omega$ to 30Ω	± 4.5 ± 3 +15 ± 3	 +17 +4 ± 65	± 5.5 ± 6 +18 ± 65	VDC VDC mA mA mA mA
TEMPERATURE RANGE Specification Thermal Resistance, θ_{JA} AP AU	Ambient Temperature	-40		+85	$^\circ C$ $^\circ C/W$ $^\circ C/W$

NOTES: (1) Characterization sample. (2) "Typical Values" are Mean values. The average of the two amplifiers is used for amplifier specific parameters. (3) "Min" and "Max" Values are mean ± 3 Standard Deviations. Worst case of the two amplifiers (Mean ± 3 Standard Deviations) is used for amplifier specific parameters. (4) I_Q typically 2mA less than I_Q due to OTA C-Output Bias Current and TTL Select Circuit Current.

The information provided herein is believed to be reliable; however, BURR-BROWN assumes no responsibility for inaccuracies or omissions. BURR-BROWN assumes no responsibility for the use of this information, and all use of such information shall be entirely at the user's own risk. Prices and specifications are subject to change without notice. No patent rights or licenses to any of the circuits described herein are implied or granted to any third party. BURR-BROWN does not authorize or warrant any BURR-BROWN product for use in life support devices and/or systems.



SPECIFICATIONS (CONT)

ELECTRICAL

AC-SPECIFICATION

Typical at $V_{CC} = \pm 5VDC$, $R_G = 750\Omega$, $I_C = \pm 37.5mA$ ($V_{IN} = 2.5V_{pp}$, $R_E = 100\Omega$), $I_C = \pm 75mA$ ($V_{IN} = 2.5V_{pp}$, $R_E = 50\Omega$), $R_{SOURCE} = 50\Omega$, and $T_A = +25^\circ C$, unless otherwise noted.

PARAMETER	CONDITIONS	OPA2662AP, AU			UNITS
		MIN	TYP	MAX	
FREQUENCY DOMAIN					
LARGE SIGNAL BANDWIDTH $I_C = \pm 37.5mA$ $I_C = \pm 75mA$ $I_C = \pm 37.5mA$ (Optimized) $I_C = \pm 75mA$ (Optimized)	$R_E = 100\Omega$, $R_C = 50\Omega$		150		MHz
	$R_E = 100\Omega$, $R_C = 25\Omega$		200		MHz
	$R_E = 100\Omega$, $R_C = 50\Omega$, $C_E = 5.6pF$		370		MHz
	$R_E = 100\Omega$, $R_C = 25\Omega$, $C_E = 5.6pF$		250		MHz
GROUP DELAY TIME Measured Input to Output (Demo Board Used)	$R_E = 100\Omega$, $R_C = 50\Omega$ B to E		1.2		ns
	B to C		2.5		ns
HARMONIC DISTORTION Second Harmonic Third Harmonic Second Harmonic Third Harmonic Second Harmonic Third Harmonic Second Harmonic Third Harmonic Second Harmonic Third Harmonic Second Harmonic Third Harmonic	$f = 10MHz$, $I_C = \pm 37.5mA$		-31		dBc
			-37		dBc
	$f = 10MHz$, $I_C = \pm 75mA$		-33		dBc
			-32		dBc
	$f = 30MHz$, $I_C = \pm 37.5mA$		-29		dBc
			-32		dBc
	$f = 30MHz$, $I_C = \pm 75mA$		-30		dBc
			-25		dBc
	$f = 50MHz$, $I_C = \pm 37.5mA$		-31		dBc
			-30		dBc
	$f = 50MHz$, $I_C = \pm 75mA$		-28		dBc
			-23		dBc
CROSTALK	Typical Curve Number 3		-51		dB
	$I_C = \pm 37.5mA$, $f = 30MHz$ $I_C = \pm 75mA$, $f = 30MHz$		-56		dB
FEEDTHROUGH Off Isolation	$R_E = 100\Omega$, $f = 30MHz$		-90		dB
	$R_E = 50\Omega$, $f = 30MHz$		-90		dB
TIME DOMAIN Rise Time Slew Rate	10% to 90%				
	75mA Step I_C		2		ns
	150mA Step I_C		2.6		ns
	$I_C = 75mA$		37.5		mA/ns
	$I_C = 150mA$		58		mA/ns

CHANNEL SELECTION

PARAMETER	CONDITIONS	OPA2662AP, AU			UNITS
		MIN	TYP	MAX	
ENABLE INPUTS Logic 1 Voltage Logic 0 Voltage Logic 1 Current Logic 0 Current		2		$V_{CC} + 0.6$	V
		0		0.8	V
	$V_{SEL} = 2.0V$ to $5V$	0.8	1.1	10	μA
	$V_{SEL} = 0V$ to $0.8V$	-1	0.05		μA
SWITCHING CHARACTERISTICS EN to Channel ON Time EN to Channel OFF Time Switching Transient, Positive Switching Transient, Negative	$I_C = 150mA_{p-p}$, $f = 5MHz$				
	90% Point of $V_O = 1V_{p-p}$		30		ns
	10% Point of $V_O = 1V_{p-p}$		200		ns
	(Measured While Switching Between the Grounded Channels)		30		mV
			-80		mV



SPECIFICATIONS (CONT)

ELECTRICAL (Full Temperature Range -40°C to +85°C)

At $V_{CC} = \pm 5VDC$, $R_Q = 750\Omega$, $T_A = T_{MIN}$ to T_{MAX} , unless otherwise noted, and configured as noted under "CONDITIONS".

PARAMETER	CONDITIONS	OPA2662AP, AU			UNITS
		MIN	TYP	MAX	
OTA INPUT OFFSET VOLTAGE Initial Matching	$R_E = 50k\Omega$, $R_C = 40\Omega$		12	± 36	mV
			2	± 7.2	mV
OTA INPUT BIAS CURRENT Initial Matching	$R_E = 100\Omega$, $R_C = 40\Omega$		-1.9	5.9	μA
			-1.2	1.2	μA
OTA TRANSCONDUCTANCE Transconductance	$I_C = 75mA$, $R_E = 0$		580	610	mA/V
OTA C-RATED OUTPUT Output Voltage Compliance	$I_C = \pm 5mA$, $R_E = 100\Omega$, $R_C = 16\Omega$		± 3.2		V
POWER SUPPLY Positive Quiescent Current for both OTAs ⁽⁴⁾	$R_Q = 750\Omega$, $R_E = 50k\Omega$, $R_C = 1k\Omega$, Both Channels Selected		+8	+17	mA

PIN CONFIGURATION

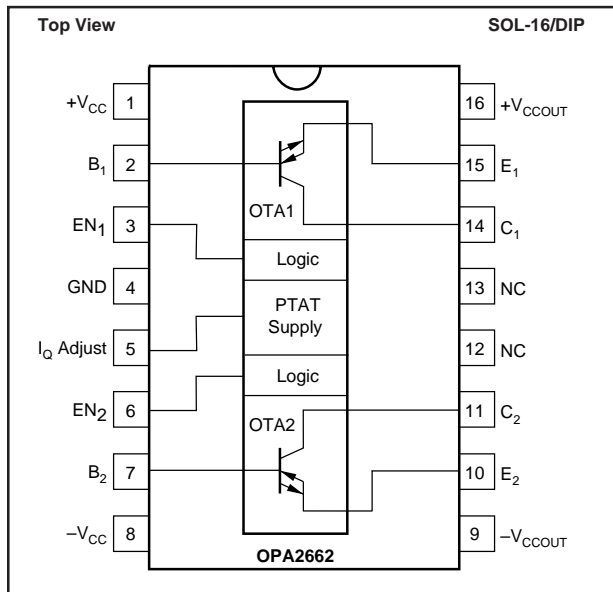

ABSOLUTE MAXIMUM RATINGS

Power Supply Voltage	$\pm 6V$
Input Voltage ⁽¹⁾	$\pm V_{CC}$ to $\pm 0.7V$
Operating Temperature	-40°C to +85°C
Storage Temperature	-40°C to +125°C
Junction Temperature	+175°C
Lead Temperature (soldering, 10s)	+300°C
Digital Input Voltages (EN ₁ , EN ₂)	-0.5 to $+V_{CC} + 0.7V$

NOTE: (1) Inputs are internally diode-clamped to $\pm V_{CC}$.

PACKAGE/ORDERING INFORMATION

PRODUCT	PACKAGE	PACKAGE DRAWING NUMBER ⁽¹⁾	TEMPERATURE RANGE
OPA2662AP	16-Pin Plastic DIP	180	-40°C to +85°C
OPA2662AU	SOL-16 Surface Mount	211	-40°C to +85°C

NOTE: (1) For detailed drawing and dimension table, please see end of data sheet, or Appendix C of Burr-Brown IC Data Book.

ELECTROSTATIC DISCHARGE SENSITIVITY

Any integrated circuit can be damaged by ESD. Burr-Brown recommends that all integrated circuits be handled with appropriate precautions. ESD can cause damage ranging from subtle performance degradation to complete device failure. Precision integrated circuits may be more susceptible to damage because very small parametric changes could cause the device not to meet published specifications.

Burr-Brown's standard ESD test method consists of five 1000V positive and negative discharges (100pF in series with 1.5k Ω) applied to each pin.

TYPICAL PERFORMANCE CURVES

At $V_{CC} = \pm 5V$, $R_Q = 750\Omega$, and $T_A = +25^\circ C$, unless otherwise specified.

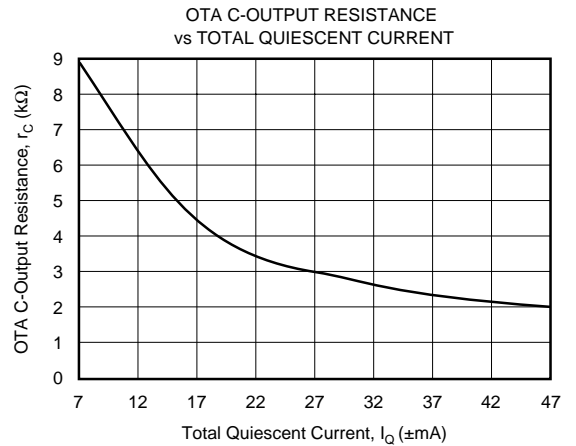
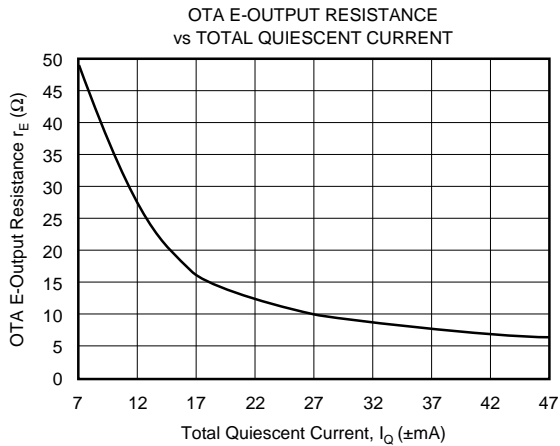
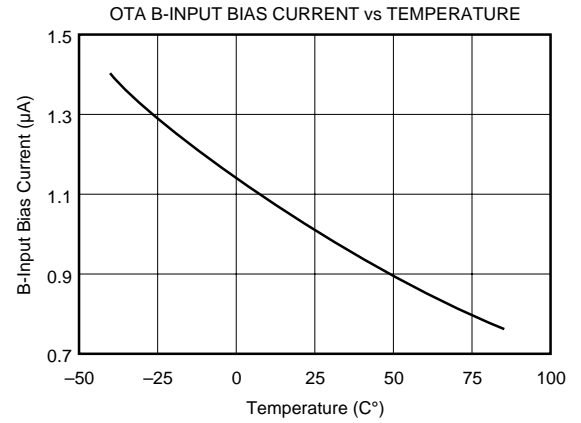
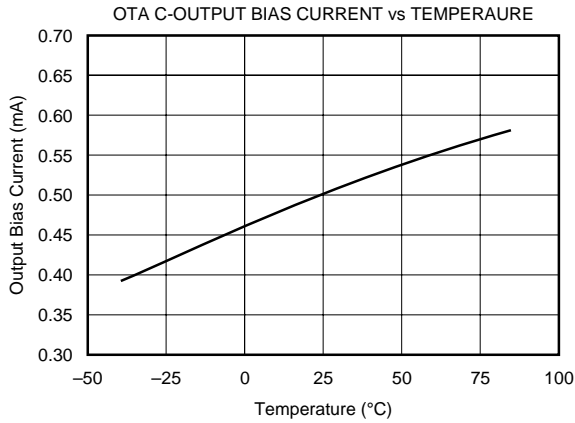
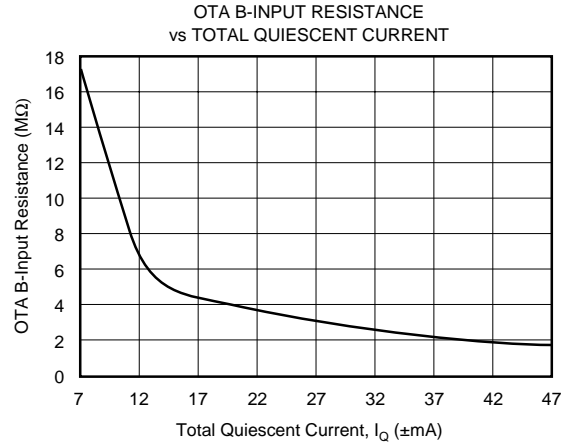
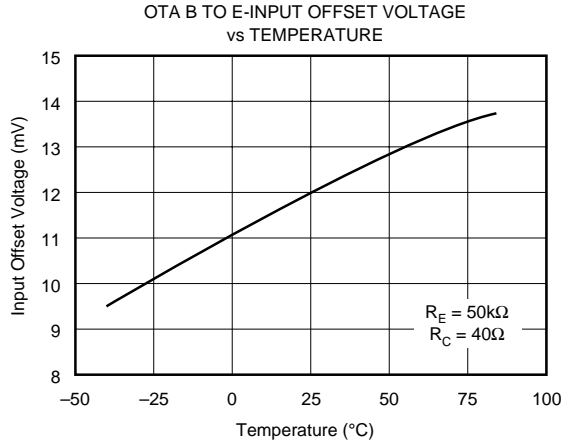

TYPICAL PERFORMANCE CURVES (CONT)

At $V_{CC} = \pm 5V$, $R_Q = 750\Omega$, and $T_A = +25^\circ C$, unless otherwise specified.

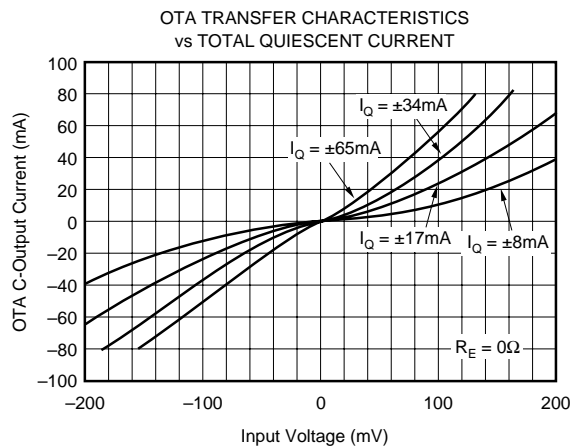
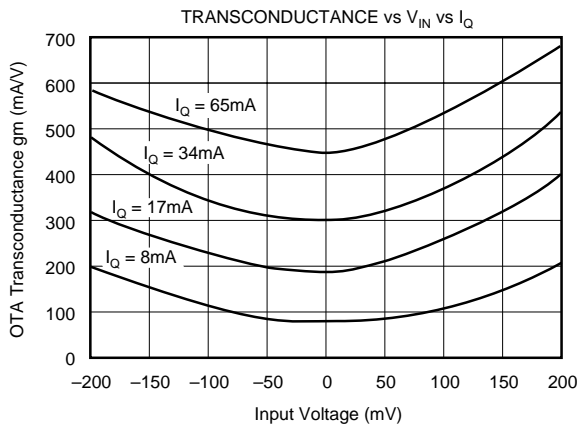
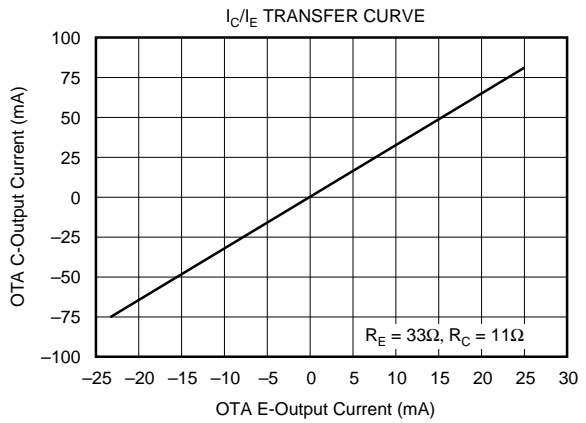
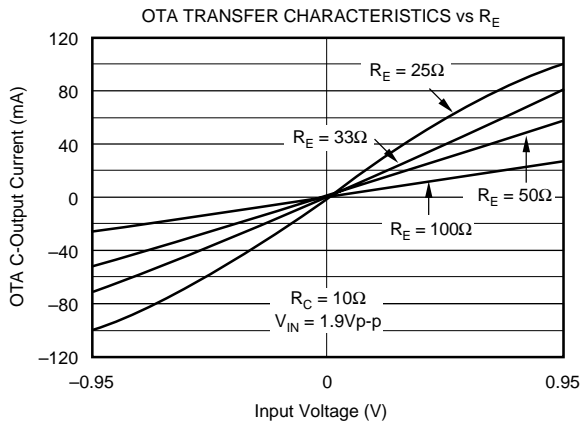
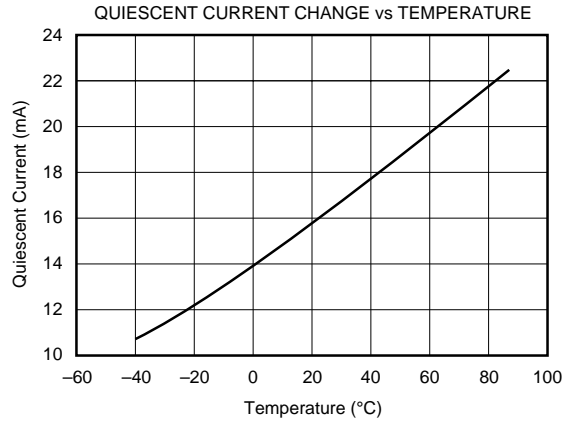
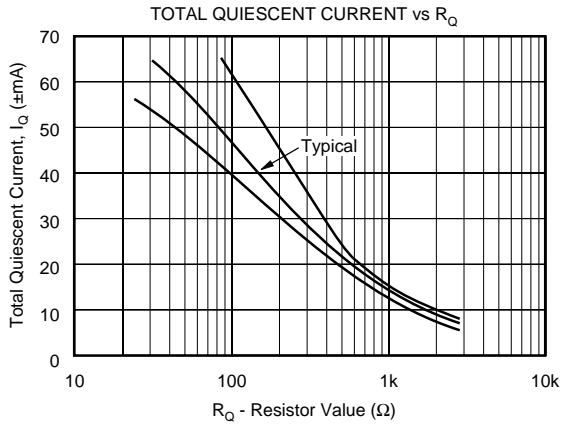

TYPICAL PERFORMANCE CURVES (CONT)

At $V_{CC} = \pm 5V$, $R_Q = 750\Omega$, $I_C = \pm 37.5mA$ ($R_E = 100\Omega$, $V_{IN} = 2.5V_{p-p}$), $I_C = \pm 75mA$ ($R_E = 50\Omega$, $V_{IN} = 2.5V_{p-p}$), and $T_{AMB} = +25^\circ C$, unless otherwise noted.

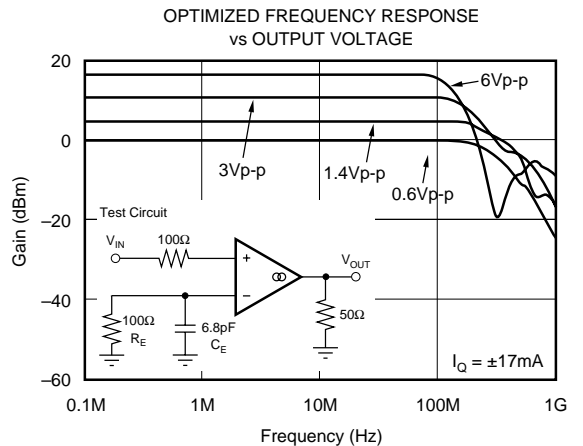
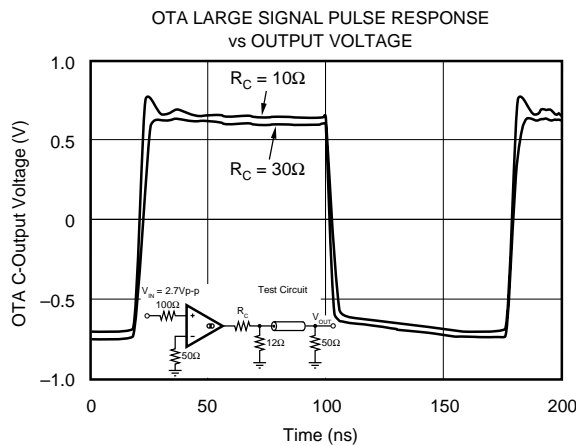
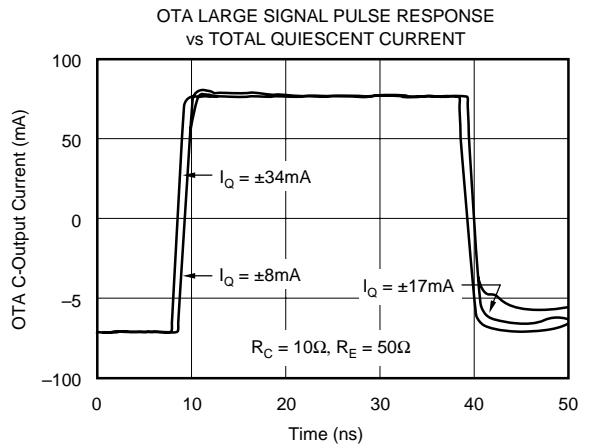
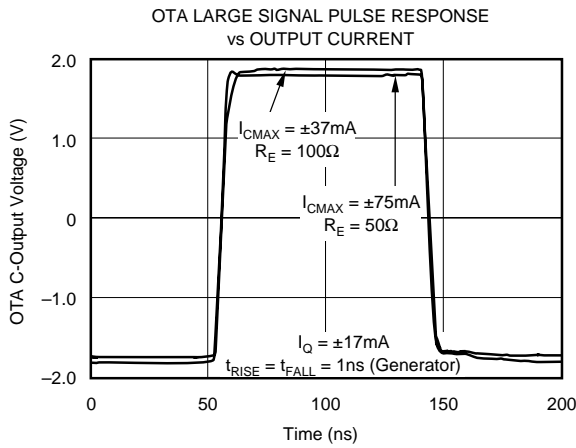
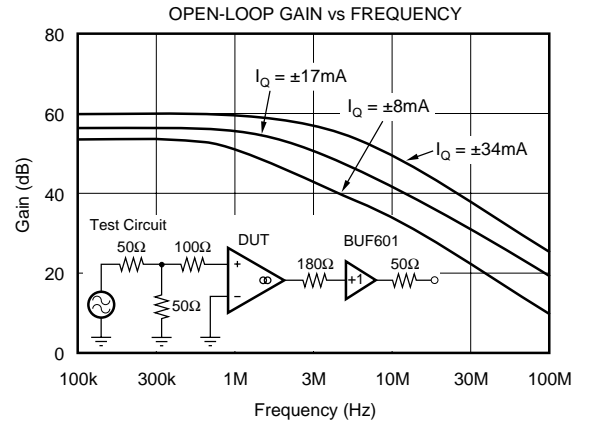
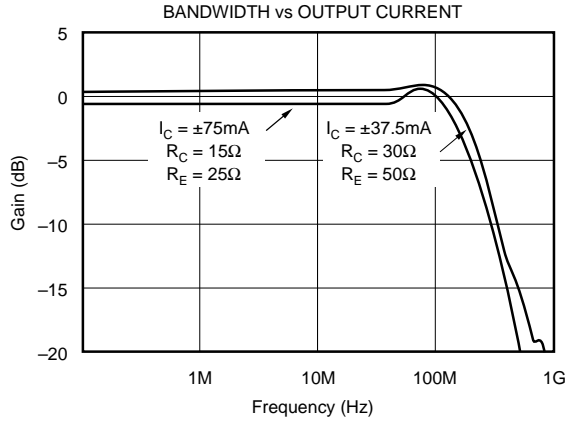

TYPICAL PERFORMANCE CURVES (CONT)

$V_{CC} = \pm 5V$, $R_Q = 750\Omega$, $I_C = \pm 37.5mA$ ($R_E = 100\Omega$, $V_{IN} = 2.5Vp-p$), $I_C = \pm 75mA$ ($R_E = 50\Omega$, $V_{IN} = 2.5Vp-p$), and $T_A = +25^\circ C$, unless otherwise specified.

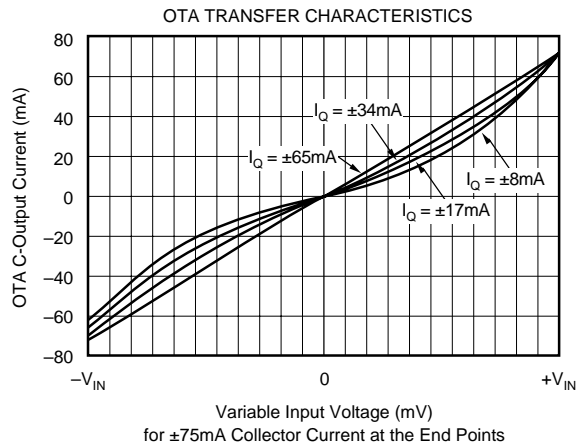
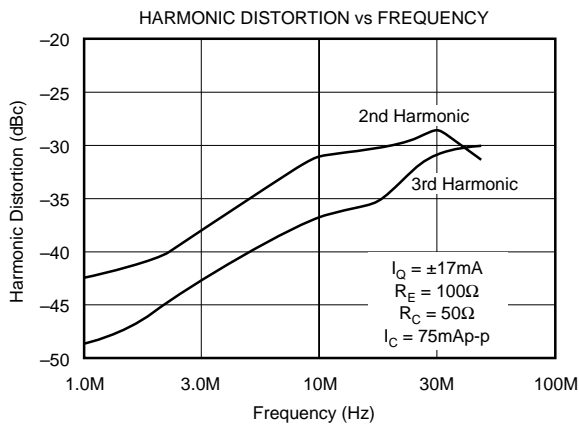
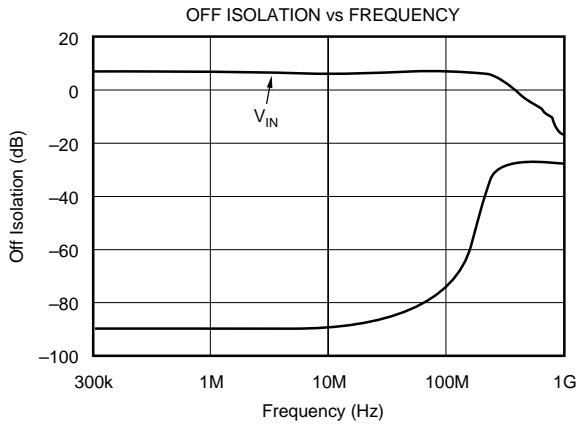
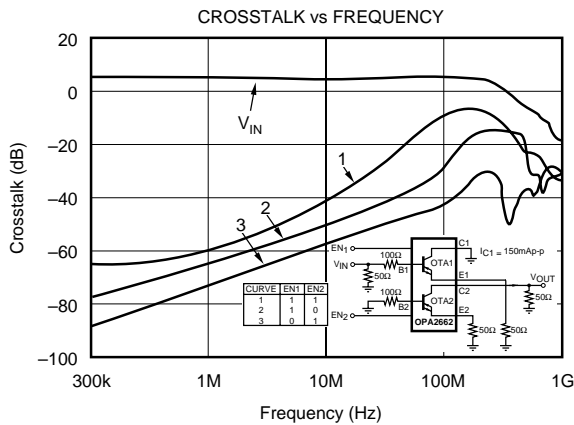
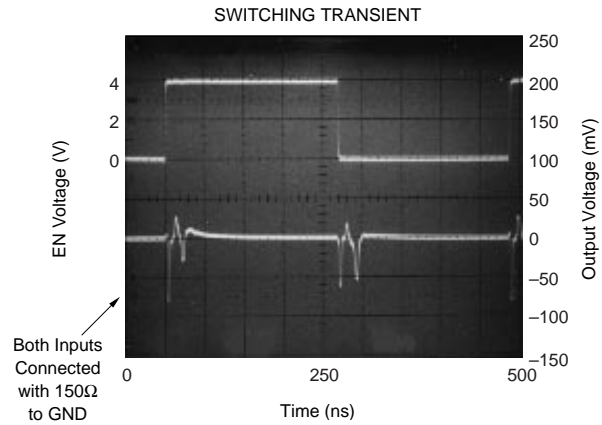
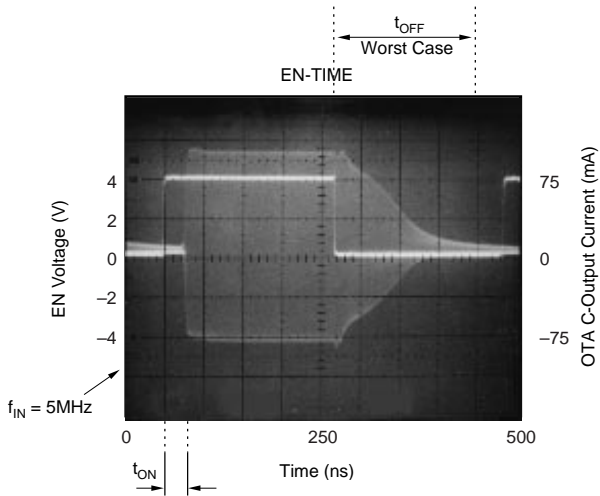

TYPICAL PERFORMANCE CURVES (CONT)

At $V_{CC} = \pm 5V$, $R_Q = 750\Omega$, ($R_E = 100\Omega$, $V_{IN} = 2.5Vp-p$), $I_C = \pm 75mA$ ($R_E = 50\Omega$, $V_{IN} = 2.5Vp-p$), and $T_A = +25^\circ C$, unless otherwise specified.

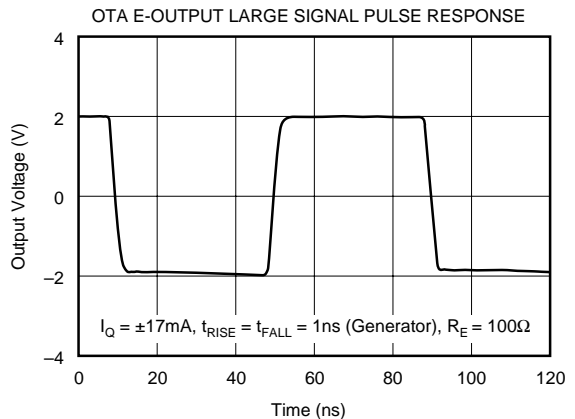
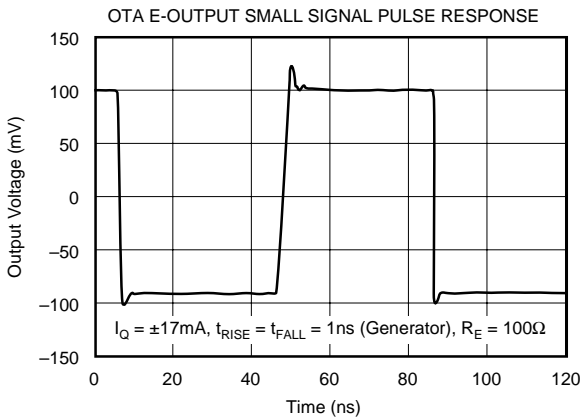
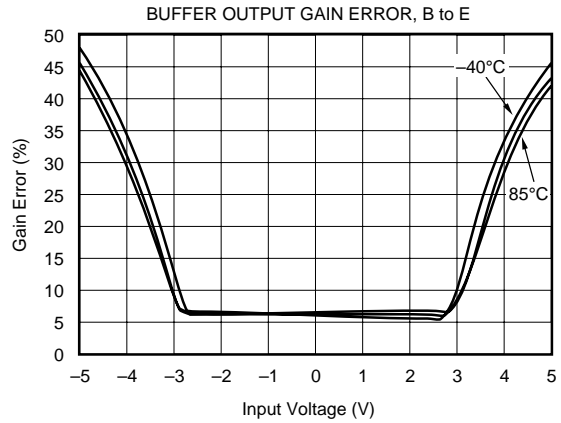
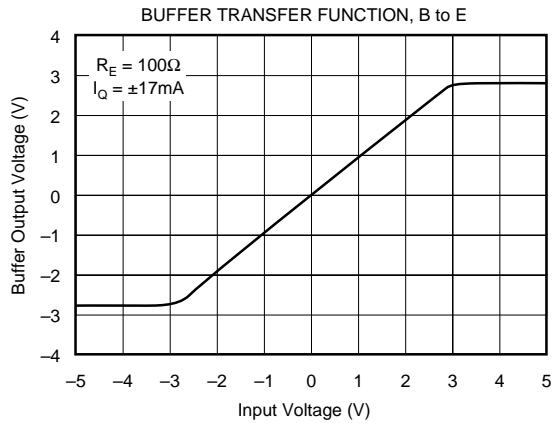
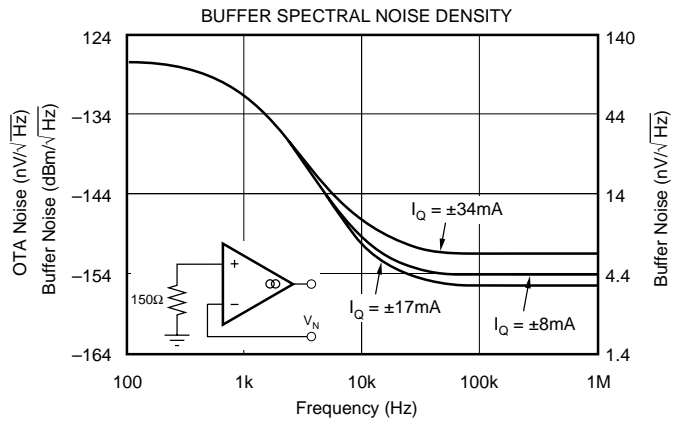
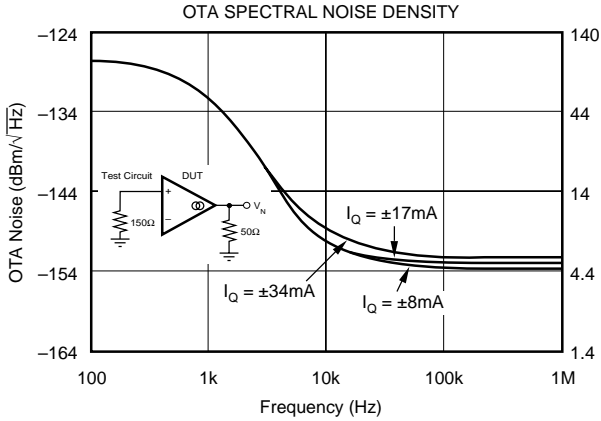

APPLICATION INFORMATION

The OPA2662 typically operates from $\pm 5V$ power supplies ($\pm 6V$ maximum). Do not attempt to operate with larger power supply voltages or permanent damage may occur. All inputs of the OPA2662 are protected by internal diode clamps, as shown in the simplified schematic in Figure 1. These protection diodes can safely, continuously conduct 10mA (30mA peak). The input signal current must be limited if input voltages can exceed the power supply voltages by 0.7V, as can occur when power supplies are switched off and a signal source is still present. The buffer outputs E_1 and E_2 are not current-limited or protected. If these outputs are shorted to ground, high currents could flow. Momentary shorts to ground (a few seconds) should be avoided, but are unlikely to cause permanent damage.

DISCUSSION OF PERFORMANCE

OTA

The two OTA sections of the OPA2662 are versatile driver devices for wide-bandwidth systems. Applications best suited to this new circuit technology are those where the output signal is current rather than voltage. Such applications include driving LEDs, laser diodes, tuning coils, and driver transformers. The OPA2662 is also an excellent choice to drive the video heads of analog or digital video tape recorders in broadcast and HDTV-quality or video heads of high-density data recorders.

The symbol for the OTA sections is similar to that of a bipolar transistor. Application circuits for the OTA look and operate much like transistor circuits—the bipolar transistor,

too, is a voltage-controlled current source. The three OTA terminals are labelled; base (B), emitter (E) and collector (C), calling attention to its similarity to a transistor. The OTA sections can be viewed as wide-band, voltage-controlled, bipolar current sources. The collector current of each OTA is controlled by the differential voltage between the high-impedance base and low-impedance emitter. If a current flows at the emitter, then the current mirror reflects this current to the high-impedance collector by a fixed ratio of three. Thus, the collector is determined by the product of the base-emitter voltage times the transconductance times the current mirror factor. The typical performance curves illustrate the OTA open-loop transfer characteristic. Due to the PTAT (Proportional to Absolute Temperature) biasing, the transconductance is constant vs temperature and can be adjusted by an external resistor. The typical performance curves show the transfer characteristic for various quiescent currents. While similar to that of a transistor, this characteristic has one essential difference, as can be seen in the performance curve: the (sense) of the C output current. This current flows out of the C terminal for positive B-to-E input voltage and into for negative.

The OTAs offer many advantages over discrete transistors. First of all, they are self-biased and bipolar. The output current is zero-for-zero differential input voltage. AC inputs centered at zero produce an output current that is bipolar and centered at zero. The self-biased OTAs simplify the design process and reduce the number of components. It is far more linear than a transistor. The transconductance of a transistor is proportional to its collector current. But since the collector current is dependent upon the signal, it and the transconductance are fundamentally nonlinear. Like transistor circuits, OTA circuits may also use emitter degeneration

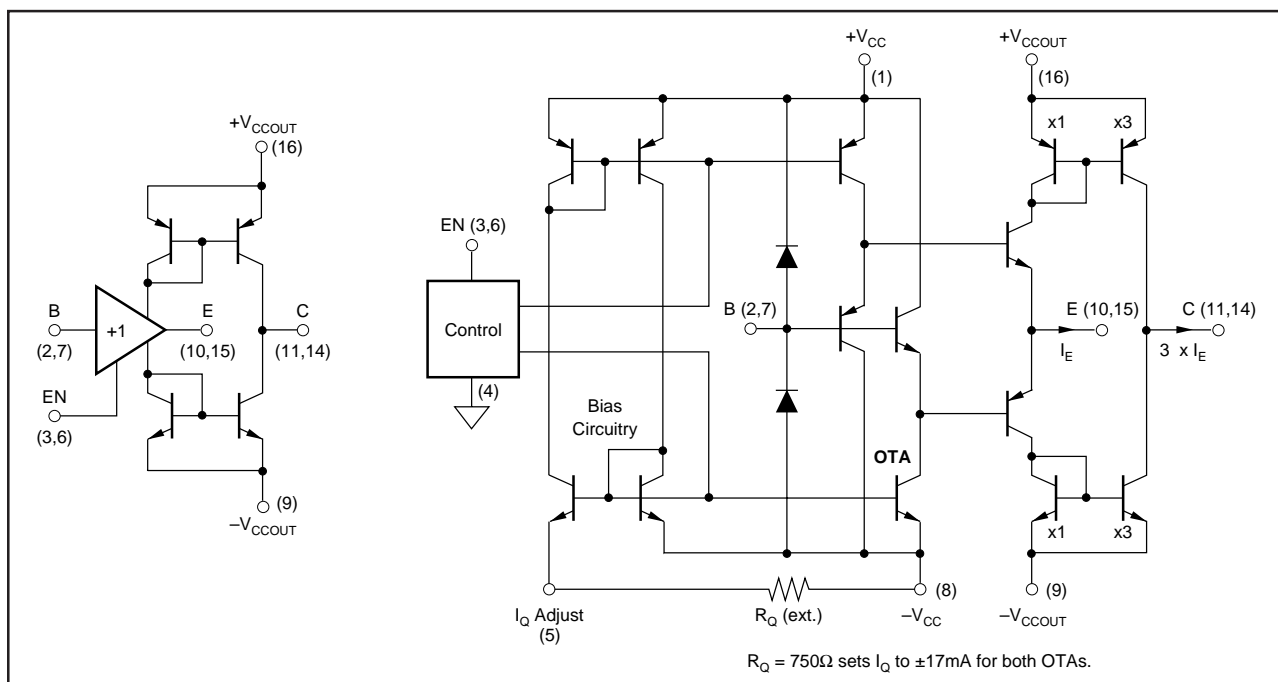

FIGURE 1. Simplified Block and Circuit Diagram.



to reduce the effect that offset voltages and currents might otherwise have on the DC operating point of the OTA. The E degeneration resistor may be bypassed by a capacitor to maintain high AC gain. Other cases may require a capacitor with less value to optimize high-frequency performance. The transconductance of the OTA with degeneration can be calculated by:

$$gm' = \frac{1}{\frac{1}{gm} + R_E}; \quad gm = \frac{1}{r_E}$$

In application circuits, the resistor R_E between the E-output and ground is used to set the OTA transfer characteristic. The input voltage is transferred with a voltage gain of 1V/V to the E-output. According to the E-output impedance and the R_E resistor size, a certain current flows to ground. As mentioned before this current is reflected by the current mirror to the high impedance collector output by a fixed ratio of three. Figure 2 and Figure 3 show the OTA transfer characteristic for a $R_E = 33\Omega$ and $R_E = 84\Omega$, which equal to voltage-to-current conversion factors (transconductance) of $\pm 75\text{mA/V}$ and $\pm 25\text{mA/V}$. The limitation for this transconductance adjustment is the maximum E-output current of $\pm 25\text{mA}$. The achievable transconductance and the corresponding minimum R_E versus the input voltage shows Figure 4. The area left to the $R_E + r_E$ curve can be used and results in a transconductance below the gm' curve. The variation of r_E vs total quiescent current is shown in the typical performance curve section.

$$I_C \approx 3 \cdot \frac{V_{IN}}{r_E + R_E}; \quad R_E \approx \frac{3 \cdot V_{IN}}{I_C} - r_E$$

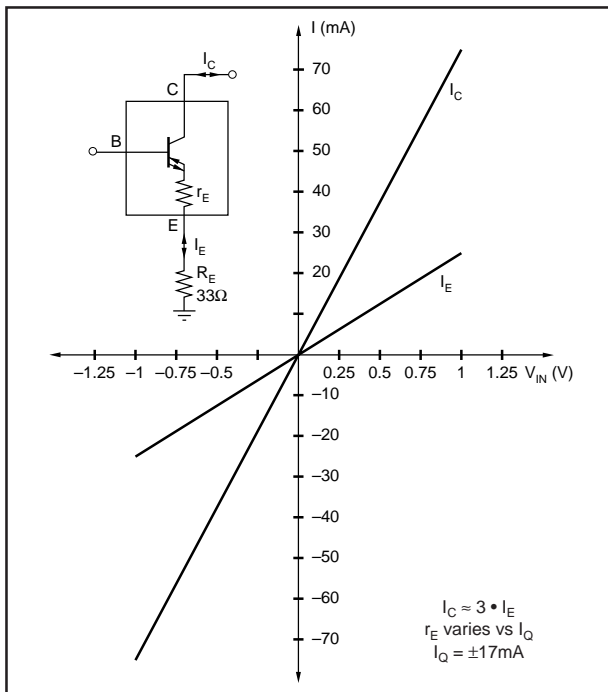

FIGURE 2. OTA Transfer Characteristic, $R_E = 33\Omega$.

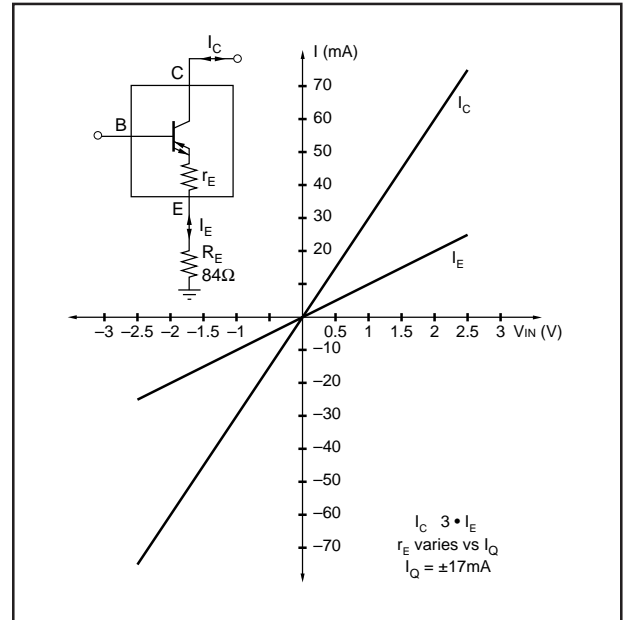

FIGURE 3. OTA Transfer Characteristic, $R_E = 84\Omega$.

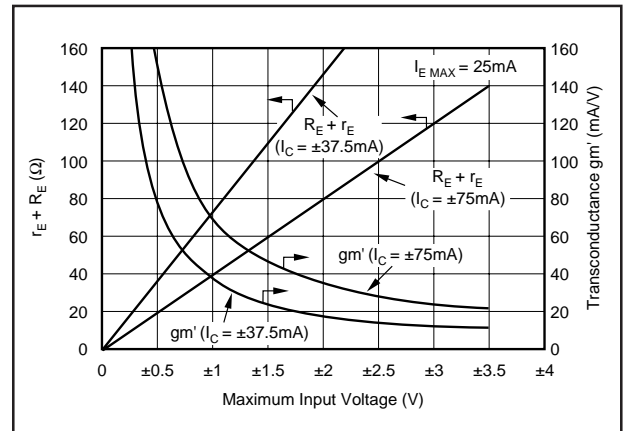

FIGURE 4. $R_E + r_E$ Selection Curve.

DISTORTION

The OPA2662's harmonic distortion characteristics into a 50Ω load are shown vs frequency in the typical performance curves for a total quiescent current of $\pm 17\text{mA}$ for both OTAs, which equals to $\pm 8.5\text{mA}$ for each of them.

The harmonic distortion performance is greatly affected by the applied quiescent current. In order to demonstrate this behavior Figure 5 illustrates the harmonic distortion performance vs frequency for a low quiescent current of $\pm 8\text{mA}$, for a medium of $\pm 17\text{mA}$ and for a high of $\pm 34\text{mA}$. It can be seen that the harmonic distortion decreases with all increasing quiescent current.

The same effect is expressed in other ways by the OTA transfer characteristics for different IQs in the typical performance curves.



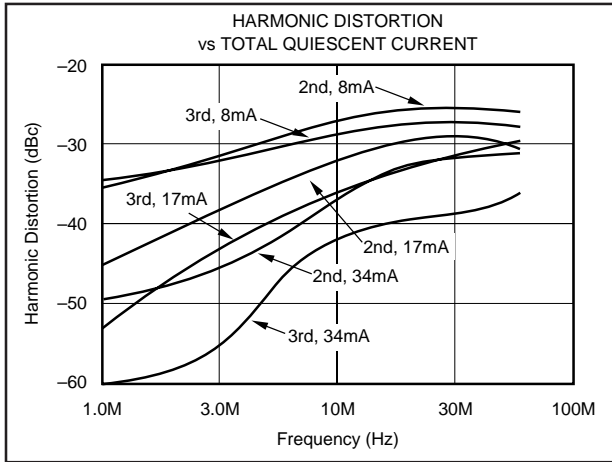

FIGURE 5. Harmonic Distortion.

BASIC CONNECTIONS

Shown in Figure 6 are the basic connections for the OPA2662's standard operation. Most of these connections are not shown in subsequent circuit diagrams for better clarification. Power supply bypass capacitors should be located as close as possible to the device pins. Solid tantalum capacitors are generally the better choice. For further details see the "Circuit Layout" section.

ENABLE INPUTS

Switching stages compatible to TTL logic levels are provided for each OTA to switch the corresponding voltage-controlled current source on within 30ns, and off within

200ns at full output power ($I_{OUT} = \pm 75\text{mA}$). This enable feature allows multiplexing and demultiplexing, or a shut-down mode, when the device is not in use. If the EN-input is connected to ground or a digital "Low" is applied to it, the collector (C) and emitter (E) pins are switched in the high-impedance mode. When the EN-input is connected to +5V (+V_{CC}) or a digital "High" is applied to it, the corresponding OTA operates at the adjusted quiescent current. The initial setting for the enable pins is that they are connected to the positive supply as shown in Figure 6.

THERMAL CONSIDERATIONS

The performance of the OPA2662 is dependent on the total quiescent current which can be externally adjusted over a wide range. As shown later, the distortion will reduce when setting the OTAs for higher quiescent current. For a reliable operation, some thermal considerations should be made. The total power dissipation consists of two separate terms:

- a) the quiescent power dissipation, P_{DQ}

$$P_{DQ} = |+V_{CC}| \cdot I_Q^+ + |V_{CC}| \cdot I_Q^- \quad (1)$$

- b) the power dissipation in the output transistors, P_{DO}

$$P_{DO} = (V_{OUT} - V_{CC}) \cdot I_{OUT} \quad (2)$$

Equations 1 and 2 can be used in conjunction with the OPA2662's absolute maximum rating of the junction temperature for a safe operation.

$$T_J = T_A + (P_{DQ} + P_{DO}) \cdot \theta_{JA} \quad (3)$$

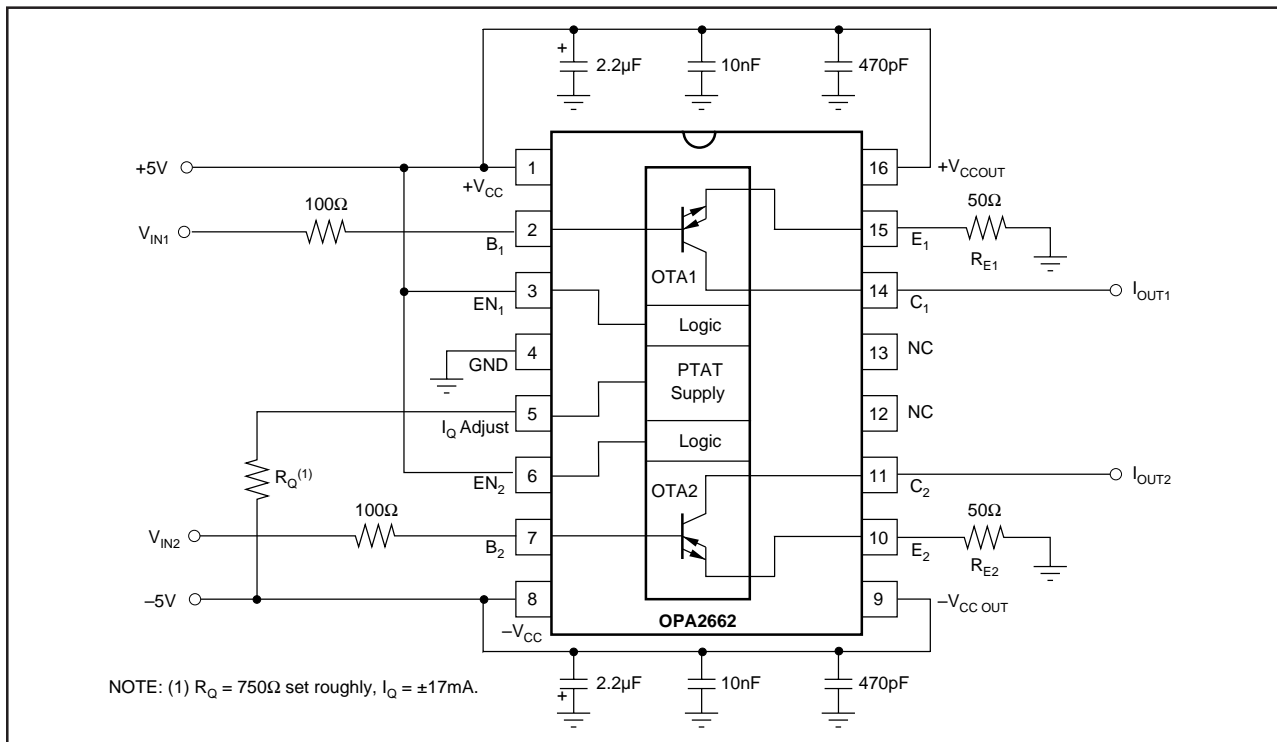

FIGURE 6. Basic Connections.



QUIESCENT CURRENT CONTROL

The quiescent current of the OPA2662 can be varied by connecting a user selectable external resistor, R_Q , between pin 5 and $-V_{CC}$. The quiescent current affects the operating currents of both OTA sections simultaneously, controlling the bandwidth and the AC-behavior as well as the transconductance. The typical performance curves illustrate the relationship of the quiescent current versus the R_Q and the transconductance, g_M . The OPA2662 is specified at a typical quiescent current of $\pm 17\text{mA}$. This is set by a resistor R_Q of 750Ω at 25°C ambient temperature. The useful range for the I_Q is from $\pm 3\text{mA}$ to $\pm 65\text{mA}$ (see Figure 7). The application circuits do not always show the resistor R_Q , but it is required for proper operation. With a fixed resistor, the quiescent current increases with increasing temperature, keeping the transconductance and AC-behavior constant. Figure 7 shows the internal current source circuitry. A resistor with a value of 150Ω is used to limit the current if pin 5 is shorted to $-V_{CC}$. This resistor has a relative accuracy of $\pm 25\%$ which causes an increasing deviation from the typical R_Q vs I_Q curve at decreasing R_Q values.

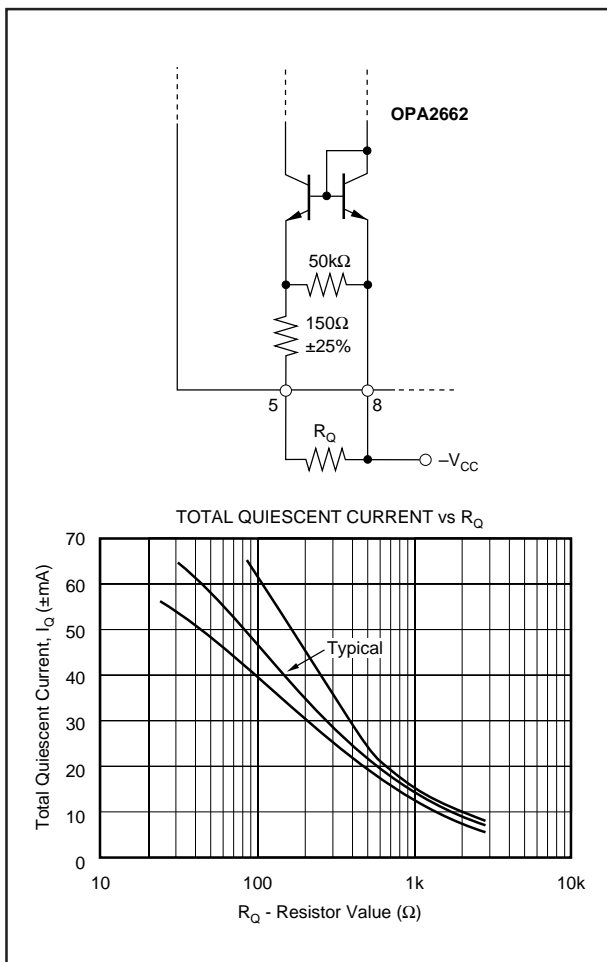

FIGURE 7. Quiescent Current Setting.

CIRCUIT LAYOUT

The high-frequency performance of the power operational transconductance amplifier OPA2662 can be greatly affected by the physical layout of the printed circuit board. The following tips are offered as suggestions, not as absolute musts. Oscillations, ringing, poor bandwidth and settling, and peaking are all typical problems that plague high-speed components when they are used incorrectly.

- Bypass power supplies very close to the device pins. Use tantalum chip capacitors (approximately $2.2\mu\text{F}$); a parallel 470pF ceramic and a $10\mu\text{F}$ chip capacitor may be added if desired. Surface-mount types are recommended because of their low lead inductance.
- PC board traces for power lines should be wide to reduce impedance or inductance.
- Make short, low-inductance traces. The entire physical circuit should be as small as possible.
- Use a low-impedance ground plane on the component side to ensure that low-impedance ground is available throughout the layout.
- Do not extend the ground plane under high-impedance nodes sensitive to stray capacitances such as the amplifier's input terminals.
- Sockets are not recommended because they add significant inductance and parasitic capacitance. If sockets must be used, consider using zero-profile solderless sockets.
- Use low-inductance, surface-mounted components. Circuits using all surface-mount components with the OPA2662 will offer the best AC performance.
- A resistor (100Ω to 250Ω) in series with the high-impedance inputs is recommended to reduce peaking.
- Plug-in prototype boards and wire-wrap boards will not function well. A clean layout using RF techniques is essential—there are no shortcuts.
- Some applications may require a limitation for the maximum output current to flow. This can be achieved by adding a resistor (about 10Ω) between supply lines 1 and 16, and, 8 and 9 (see also Figure 8). The tradeoff of this technique is a reduced output voltage swing. This is due to the voltage drop across the resistors caused by both the collector and the emitter currents.



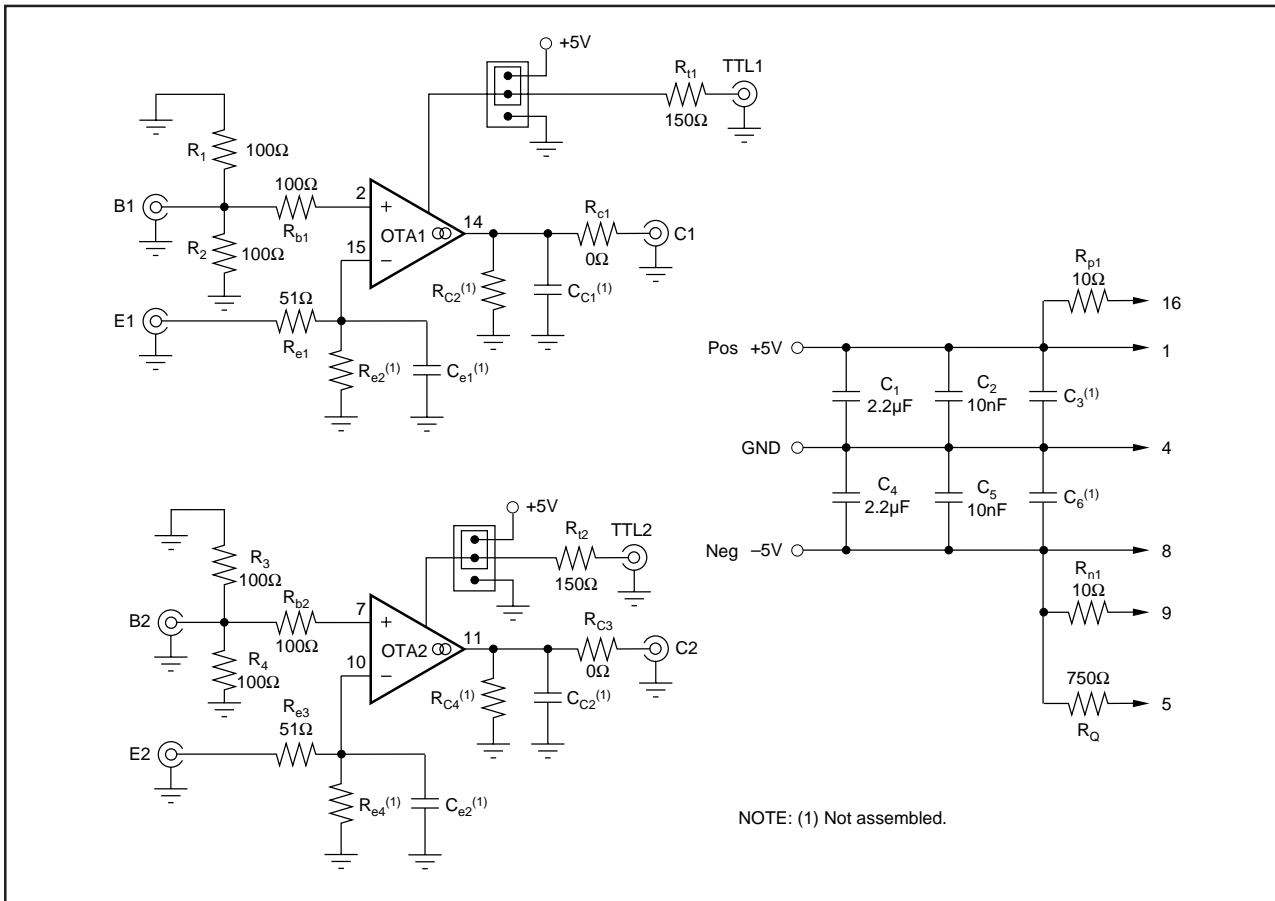

FIGURE 8. Evaluation Circuit Schematic.

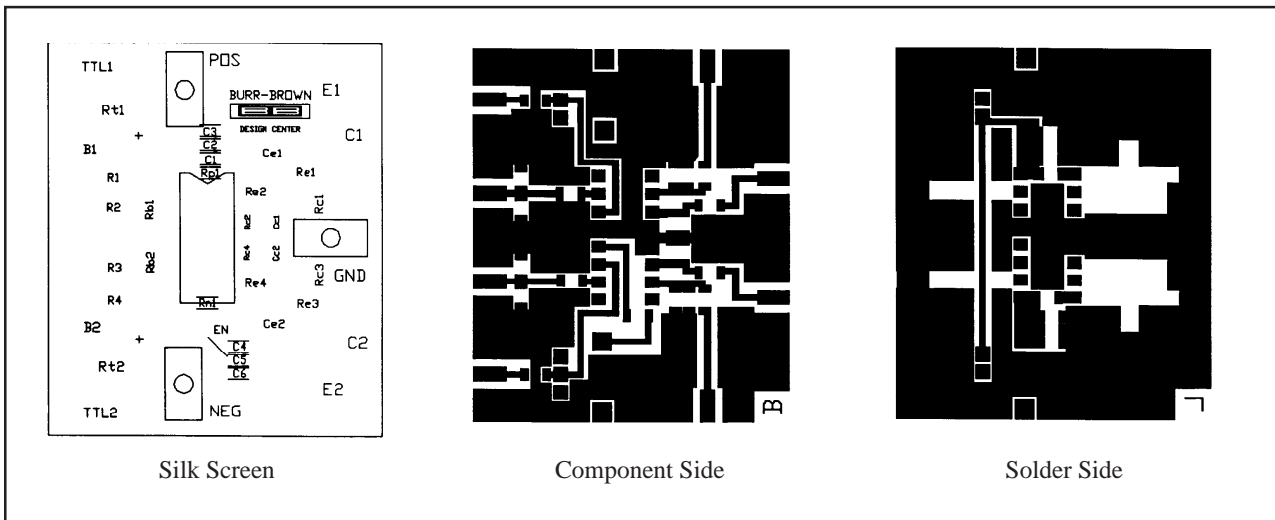

FIGURE 9. Evaluation Circuit Silkscreen and Board Layouts.

TYPICAL APPLICATIONS

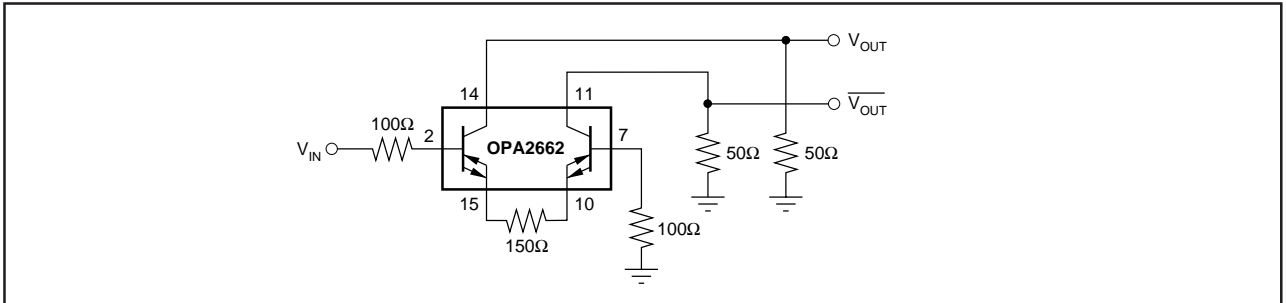

FIGURE 10. Single Ended-to-Differential Line Driver.

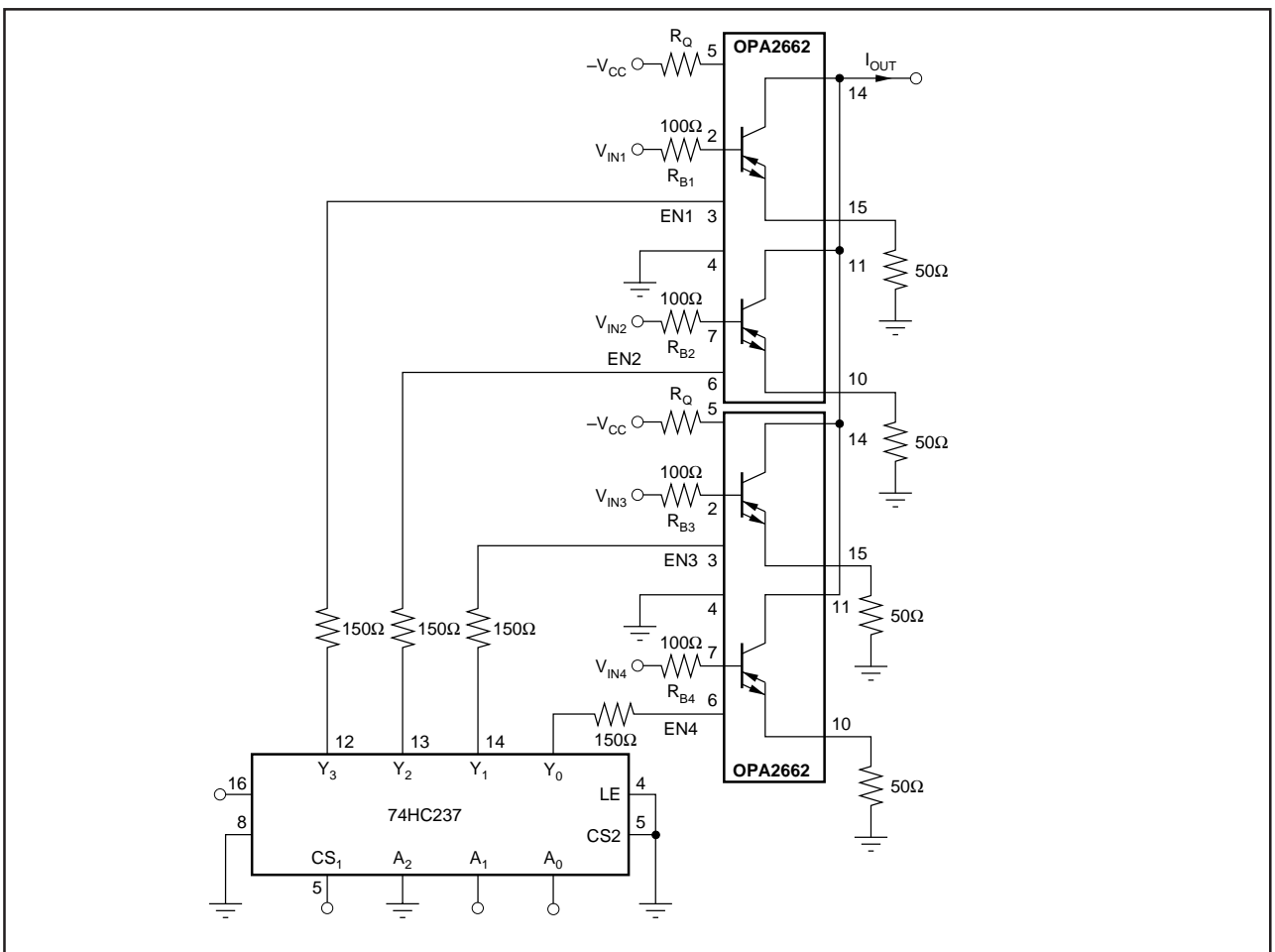

FIGURE 11. Current Distribution Multiplexer.



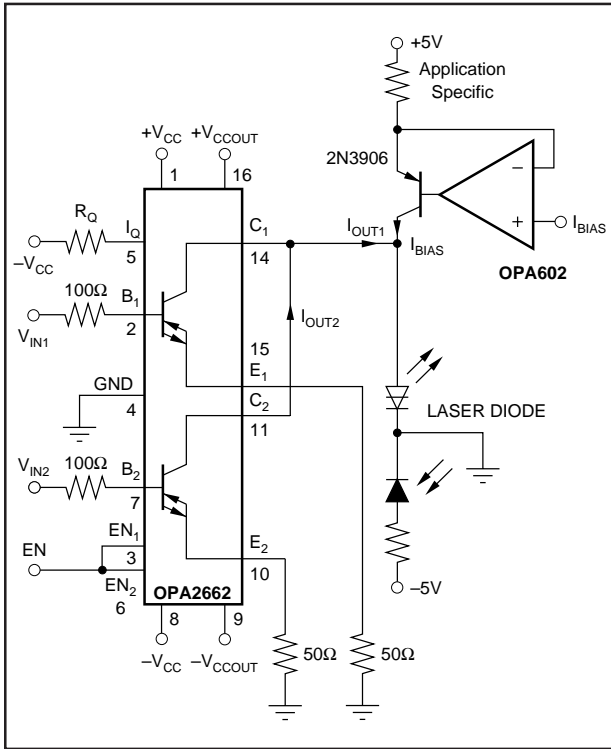

FIGURE 12. Laser Diode Driver.

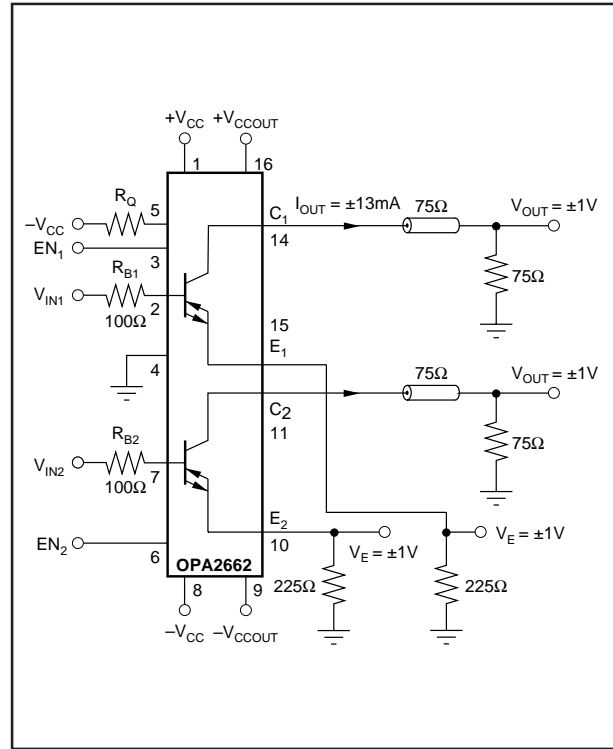

FIGURE 13. Two-Channel Current Output Driver.

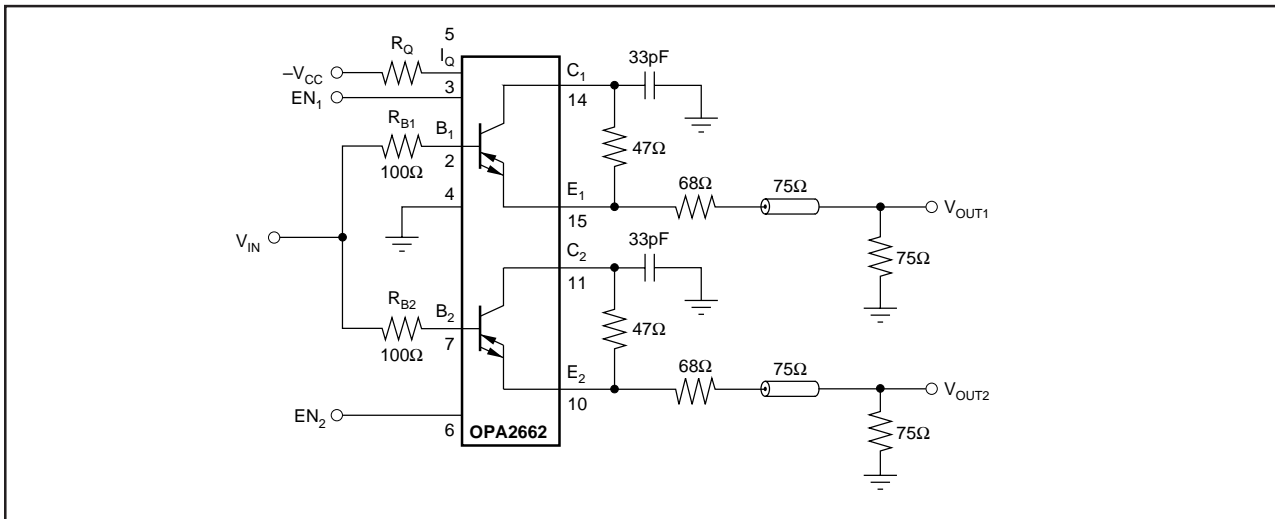

FIGURE 14. Direct Feedback Buffer and 1 to 2 Demultiplexer.



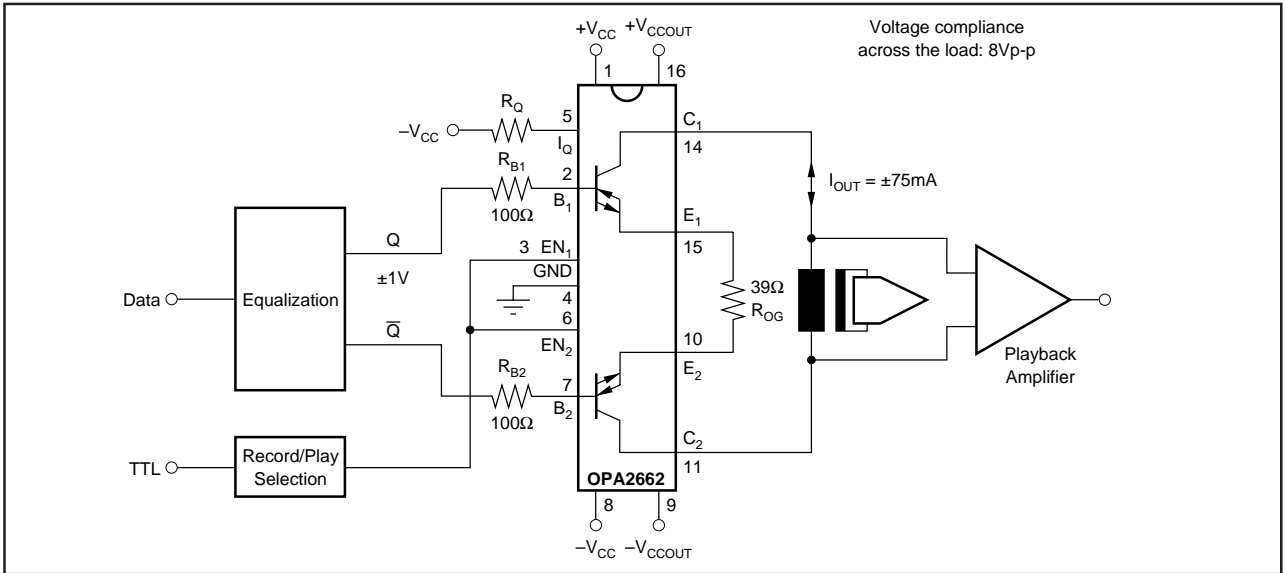

FIGURE 15. Analog-to-Digital Video Tape Record Amplifier.

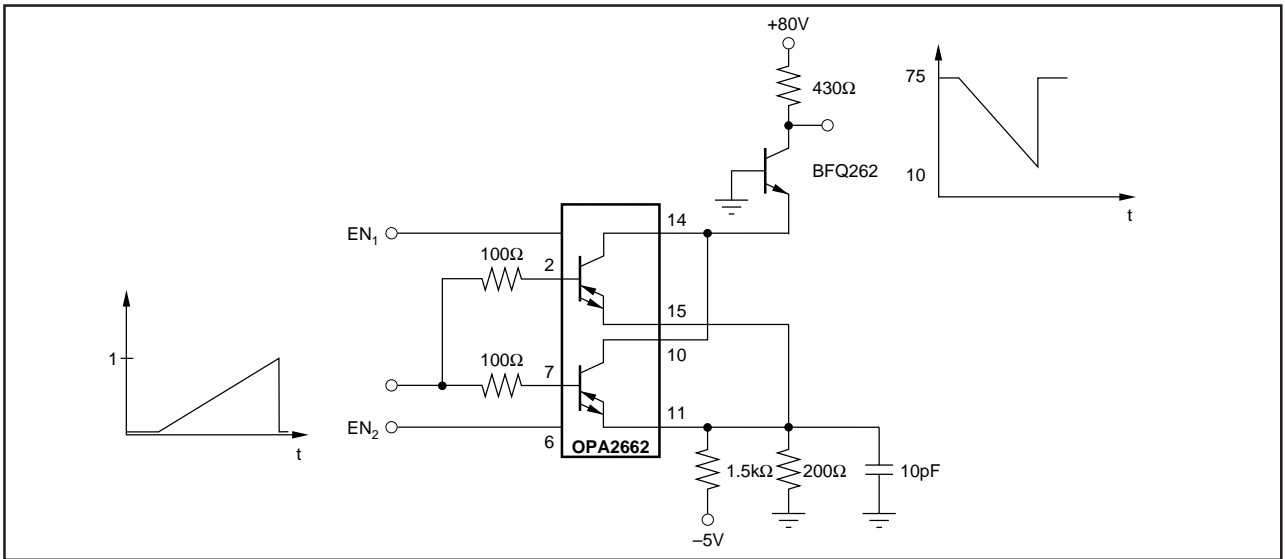

FIGURE 16. Cascode Stage Driver.

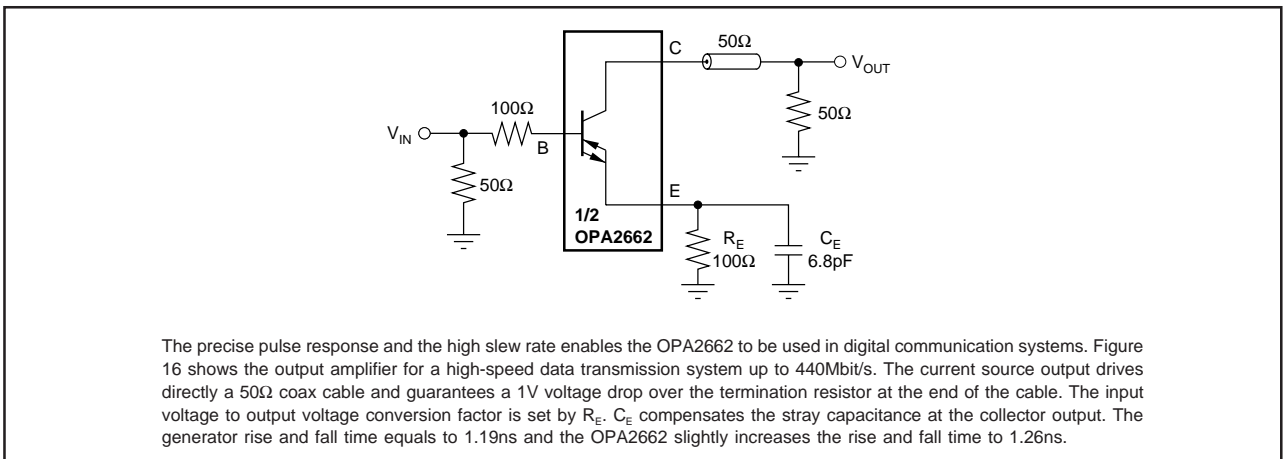

FIGURE 17. Driver Amplifier for a Digital 440Mbit/s Transmission System.



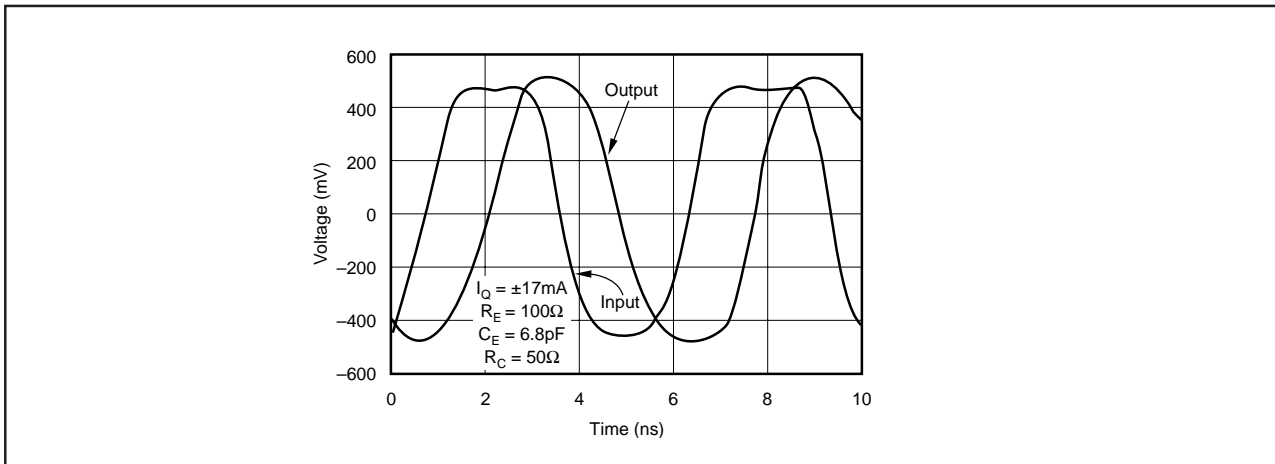

FIGURE 18. Pulse Response of the 400Mbit/s Line Driver.

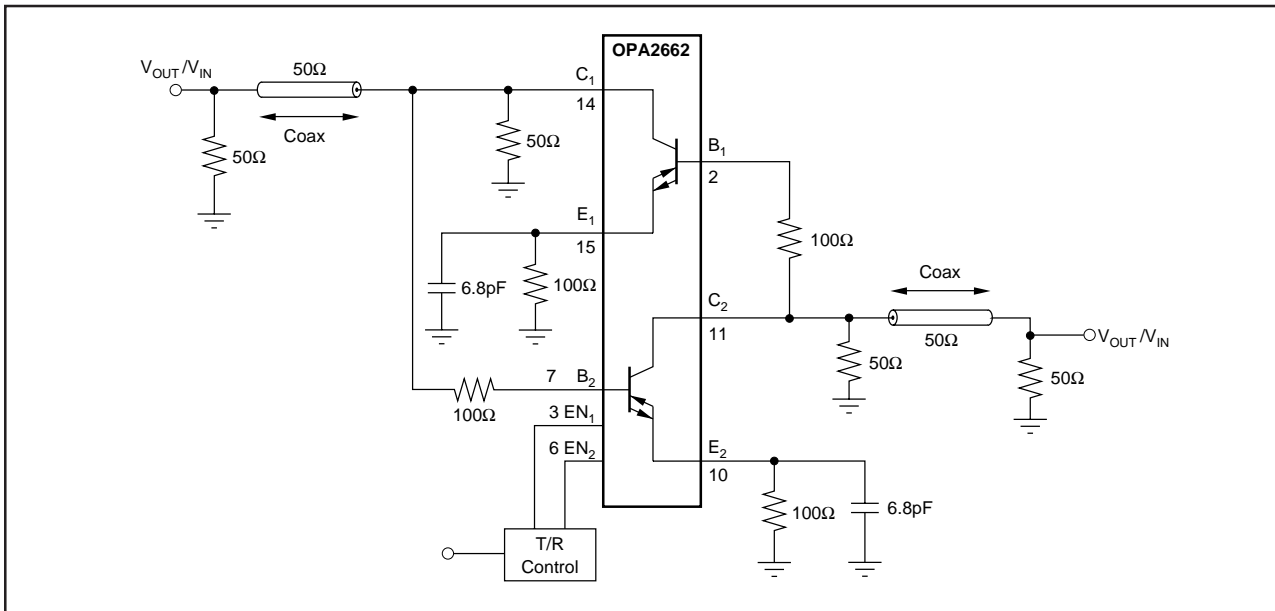

FIGURE 19. Bidirectional Line Driver.

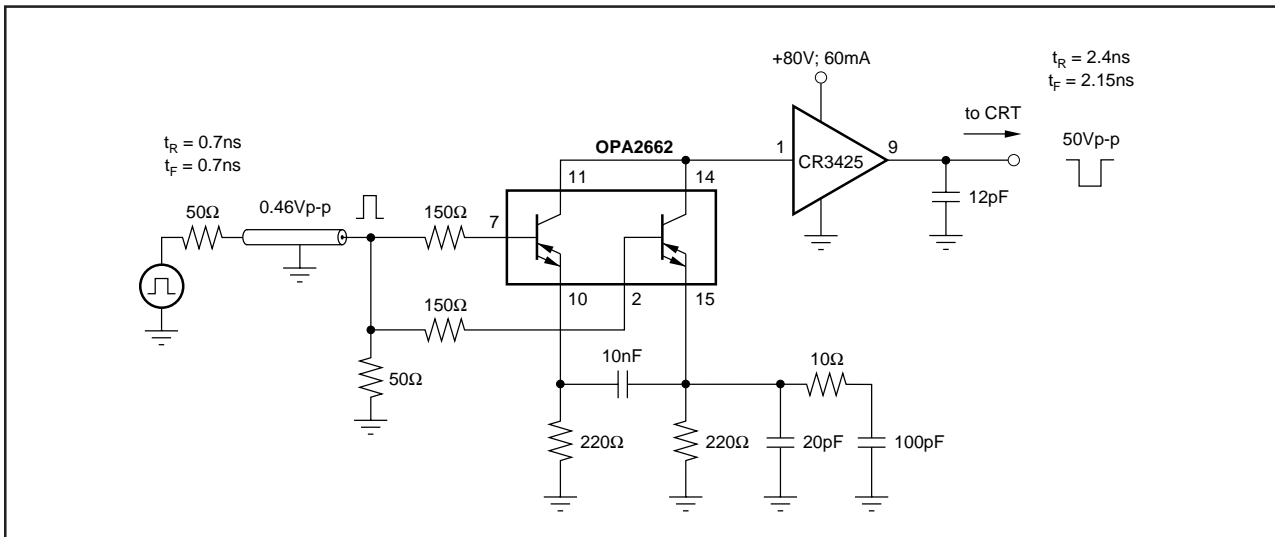

FIGURE 20. CRT Output Stage Driver for a 1600 x 1200 High-Resolution Graphic Monitor.

