

## Advance Information

# Low-Voltage 1.65/2.5/3.3V 16-Bit Buffer

## With 3.6V-Tolerant Inputs and Outputs (3-State, Inverting)

The MC74VCX16240 is an advanced performance, inverting 16-bit buffer. It is designed for very high-speed, very low-power operation in 1.65V, 2.5V or 3.3V systems.

When operating at 2.5V (or 1.65V) the part is designed to tolerate voltages it may encounter on either inputs or outputs when interfacing to 3.3V busses. It is guaranteed to be over-voltage tolerant to 3.6V.

The MC74VCX16240 is nibble controlled with each nibble functioning identically, but independently. The control pins may be tied together to obtain full 16-bit operation. The 3-state outputs are controlled by an Output Enable ( $\overline{OE_n}$ ) input for each nibble. When  $\overline{OE_n}$  is LOW, the outputs are on. When  $\overline{OE_n}$  is HIGH, the outputs are in the high impedance state.

- Designed for Low Voltage Operation:  $V_{CC} = 1.65\text{--}3.6\text{V}$
- 3.6V Tolerant Inputs and Outputs
- High Speed Operation: 2.5ns max for 3.0 to 3.6V  
3.0ns max for 2.3 to 2.7V  
6.0ns max for 1.65 to 1.95V
- Static Drive:  $\pm 24\text{mA}$  Drive at 3.0V  
 $\pm 18\text{mA}$  Drive at 2.3V  
 $\pm 6\text{mA}$  Drive at 1.65V
- Supports Live Insertion and Withdrawal
- I<sub>OFF</sub> Specification Guarantees High Impedance When  $V_{CC} = 0\text{V}$
- Near Zero Static Supply Current in All Three Logic States (20 $\mu\text{A}$ )  
Substantially Reduces System Power Requirements
- Latchup Performance Exceeds  $\pm 300\text{mA}$  @ 125°C
- ESD Performance: Human Body Model >2000V; Machine Model >200V

# MC74VCX16240

# VCX

## LOW-VOLTAGE 1.65/2.5/3.3V 16-BIT BUFFER

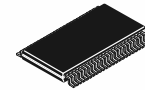

**DT SUFFIX**  
48-LEAD PLASTIC TSSOP PACKAGE  
CASE 1201-01

### PIN NAMES

Pins	Function
$\overline{OE_n}$	Output Enable Inputs
D0–D15	Inputs
O0–O15	Outputs



# MC74VCX16240

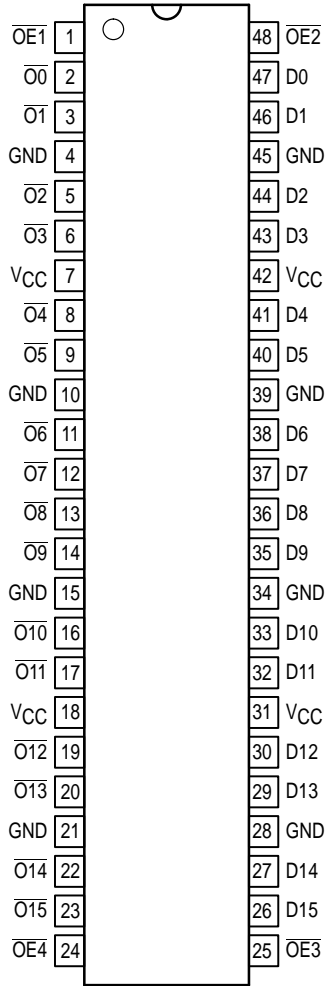

**Figure 1. 48-Lead Pinout**  
(Top View)

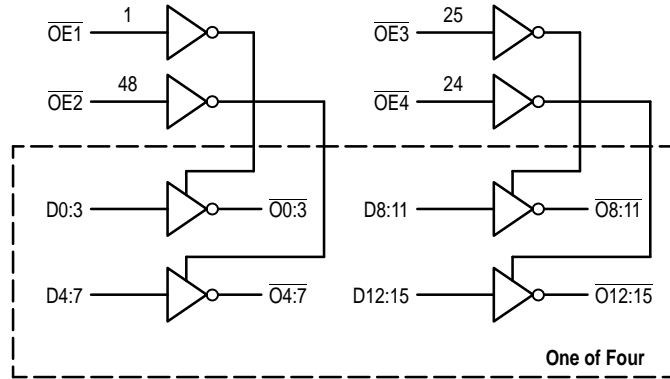

**Figure 2. Logic Diagram**

OE1	D0:3	O0:3	OE2	D4:7	O4:7	OE3	D8:11	O8:11	OE4	D12:15	O12:15
L	L	H	L	L	H	L	L	H	L	L	H
L	H	L	L	H	L	L	H	L	L	H	L
H	X	Z	H	X	Z	H	X	Z	H	X	Z

H = High Voltage Level; L = Low Voltage Level; Z = High Impedance State; X = High or Low Voltage Level and Transitions Are Acceptable, for I<sub>CC</sub> reasons, DO NOT FLOAT Inputs

**ABSOLUTE MAXIMUM RATINGS\***

Symbol	Parameter	Value	Condition	Unit
V <sub>CC</sub>	DC Supply Voltage	-0.5 to +4.6		V
V <sub>I</sub>	DC Input Voltage	-0.5 ≤ V <sub>I</sub> ≤ +4.6		V
V <sub>O</sub>	DC Output Voltage	-0.5 ≤ V <sub>O</sub> ≤ +4.6	Output in 3-State	V
		-0.5 ≤ V <sub>O</sub> ≤ V <sub>CC</sub> + 0.5	Note 1.; Outputs Active	V
I <sub>IK</sub>	DC Input Diode Current	-50	V <sub>I</sub> < GND	mA
I <sub>OK</sub>	DC Output Diode Current	-50	V <sub>O</sub> < GND	mA
		+50	V <sub>O</sub> > V <sub>CC</sub>	mA
I <sub>O</sub>	DC Output Source/Sink Current	±50		mA
I <sub>CC</sub>	DC Supply Current Per Supply Pin	±100		mA
I <sub>GND</sub>	DC Ground Current Per Ground Pin	±100		mA
T <sub>STG</sub>	Storage Temperature Range	-65 to +150		°C

\* Absolute maximum continuous ratings are those values beyond which damage to the device may occur. Exposure to these conditions or conditions beyond those indicated may adversely affect device reliability. Functional operation under absolute-maximum-rated conditions is not implied.

1. I<sub>O</sub> absolute maximum rating must be observed.

**RECOMMENDED OPERATING CONDITIONS**

Symbol	Parameter	Min	Max	Unit	
V <sub>CC</sub>	Supply Voltage	Operating	1.65	3.6	V
		Data Retention Only	1.2	3.6	
V <sub>I</sub>	Input Voltage	-0.3	3.6	V	
V <sub>O</sub>	Output Voltage	(Active State)	0	V <sub>CC</sub>	V
		(3-State)	0	3.6	
I <sub>OH</sub>	HIGH Level Output Current, V <sub>CC</sub> = 3.0V – 3.6V		-24	mA	
I <sub>OL</sub>	LOW Level Output Current, V <sub>CC</sub> = 3.0V – 3.6V		24	mA	
I <sub>OH</sub>	HIGH Level Output Current, V <sub>CC</sub> = 2.3V – 2.7V		-18	mA	
I <sub>OL</sub>	LOW Level Output Current, V <sub>CC</sub> = 2.3V – 2.7V		18	mA	
I <sub>OH</sub>	HIGH Level Output Current, V <sub>CC</sub> = 1.65 – 1.95V		-6	mA	
I <sub>OL</sub>	LOW Level Output Current, V <sub>CC</sub> = 1.65 – 1.95V		6	mA	
T <sub>A</sub>	Operating Free-Air Temperature	-40	+85	°C	
Δt/ΔV	Input Transition Rise or Fall Rate, V <sub>IN</sub> from 0.8V to 2.0V, V <sub>CC</sub> = 3.0V	0	10	ns/V	

# MC74VCX16240

## DC ELECTRICAL CHARACTERISTICS (2.7V < V<sub>CC</sub> ≤ 3.6V)

Symbol	Characteristic	Condition	T <sub>A</sub> = -40°C to +85°C		Unit
			Min	Max	
V <sub>IH</sub>	HIGH Level Input Voltage (Note 2.)	2.7V < V <sub>CC</sub> ≤ 3.6V	2.0		V
V <sub>IL</sub>	LOW Level Input Voltage (Note 2.)	2.7V < V <sub>CC</sub> ≤ 3.6V		0.8	V
V <sub>OH</sub>	HIGH Level Output Voltage	2.7V < V <sub>CC</sub> ≤ 3.6V; I <sub>OH</sub> = -100μA	V <sub>CC</sub> - 0.2		V
		V <sub>CC</sub> = 2.7V; I <sub>OH</sub> = -12mA	2.2		
		V <sub>CC</sub> = 3.0V; I <sub>OH</sub> = -18mA	2.4		
		V <sub>CC</sub> = 3.0V; I <sub>OH</sub> = -24mA	2.2		
V <sub>OL</sub>	LOW Level Output Voltage	2.7V < V <sub>CC</sub> ≤ 3.6V; I <sub>OL</sub> = 100μA		0.2	V
		V <sub>CC</sub> = 2.7V; I <sub>OL</sub> = 12mA		0.4	
		V <sub>CC</sub> = 3.0V; I <sub>OL</sub> = 18mA		0.4	
		V <sub>CC</sub> = 3.0V; I <sub>OL</sub> = 24mA		0.55	
I <sub>I</sub>	Input Leakage Current	2.7V < V <sub>CC</sub> ≤ 3.6V; 0V ≤ V <sub>I</sub> ≤ 3.6V		±5.0	μA
I <sub>OZ</sub>	3-State Output Current	2.7V < V <sub>CC</sub> ≤ 3.6V; 0V ≤ V <sub>O</sub> ≤ 3.6V; V <sub>I</sub> = V <sub>IH</sub> or V <sub>IL</sub>		±10	μA
I <sub>OFF</sub>	Power-Off Leakage Current	V <sub>CC</sub> = 0V; 0V ≤ (V <sub>I</sub> , V <sub>O</sub> ) ≤ 3.6V		10	μA
I <sub>CC</sub>	Quiescent Supply Current	2.7V < V <sub>CC</sub> ≤ 3.6V; V <sub>I</sub> = GND or V <sub>CC</sub>		20	μA
		2.7V < V <sub>CC</sub> ≤ 3.6V; V <sub>CC</sub> ≤ (V <sub>I</sub> , V <sub>O</sub> ) ≤ 3.6V		±20	μA
ΔI <sub>CC</sub>	Increase in I <sub>CC</sub> per Input	2.7V < V <sub>CC</sub> ≤ 3.6V; V <sub>IH</sub> = V <sub>CC</sub> - 0.6V		750	μA

2. These values of V<sub>I</sub> are used to test DC electrical characteristics only.

## DC ELECTRICAL CHARACTERISTICS (2.3V ≤ V<sub>CC</sub> ≤ 2.7V)

Symbol	Characteristic	Condition	T <sub>A</sub> = -40°C to +85°C		Unit
			Min	Max	
V <sub>IH</sub>	HIGH Level Input Voltage (Note 3.)	2.3V ≤ V <sub>CC</sub> ≤ 2.7V	1.6		V
V <sub>IL</sub>	LOW Level Input Voltage (Note 3.)	2.3V ≤ V <sub>CC</sub> ≤ 2.7V		0.7	V
V <sub>OH</sub>	HIGH Level Output Voltage	2.3V ≤ V <sub>CC</sub> ≤ 2.7V; I <sub>OH</sub> = -100μA	V <sub>CC</sub> - 0.2		V
		V <sub>CC</sub> = 2.3V; I <sub>OH</sub> = -6mA	2.0		
		V <sub>CC</sub> = 2.3V; I <sub>OH</sub> = -12mA	1.8		
		V <sub>CC</sub> = 2.3V; I <sub>OH</sub> = -18mA	1.7		
V <sub>OL</sub>	LOW Level Output Voltage	2.3V ≤ V <sub>CC</sub> ≤ 2.7V; I <sub>OL</sub> = 100μA		0.2	V
		V <sub>CC</sub> = 2.3V; I <sub>OL</sub> = 12mA		0.4	
		V <sub>CC</sub> = 2.3V; I <sub>OL</sub> = 18mA		0.6	
I <sub>I</sub>	Input Leakage Current	2.3V ≤ V <sub>CC</sub> ≤ 2.7V; 0V ≤ V <sub>I</sub> ≤ 3.6V		±5.0	μA
I <sub>OZ</sub>	3-State Output Current	2.3V ≤ V <sub>CC</sub> ≤ 2.7V; 0V ≤ V <sub>O</sub> ≤ 3.6V; V <sub>I</sub> = V <sub>IH</sub> or V <sub>IL</sub>		±10	μA
I <sub>OFF</sub>	Power-Off Leakage Current	V <sub>CC</sub> = 0V; 0V ≤ (V <sub>I</sub> , V <sub>O</sub> ) ≤ 3.6V		10	μA
I <sub>CC</sub>	Quiescent Supply Current	2.3V ≤ V <sub>CC</sub> ≤ 2.7V; V <sub>I</sub> = GND or V <sub>CC</sub>		20	μA
		2.3V ≤ V <sub>CC</sub> ≤ 2.7V; V <sub>CC</sub> ≤ (V <sub>I</sub> , V <sub>O</sub> ) ≤ 3.6V		±20	μA

3. These values of V<sub>I</sub> are used to test DC electrical characteristics only.

**DC ELECTRICAL CHARACTERISTICS** ( $1.65V \leq V_{CC} < 1.95V$ )

Symbol	Characteristic	Condition	$T_A = -40^\circ\text{C to } +85^\circ\text{C}$		Unit
			Min	Max	
$V_{IH}$	HIGH Level Input Voltage	$1.65V \leq V_{CC} < 1.95V$	$0.7 \times V_{CC}$		V
$V_{IL}$	LOW Level Input Voltage	$1.65V \leq V_{CC} < 1.95V$		$0.2 \times V_{CC}$	V
$V_{OH}$	HIGH Level Output Voltage	$V_{CC} = 1.65 - 1.95V; I_{OH} = -100\mu\text{A}$	$V_{CC} - 0.2$		V
		$V_{CC} = 1.65V; I_{OH} = -6\text{mA}$	1.25		
$V_{OL}$	LOW Level Output Voltage	$V_{CC} = 1.65 - 1.95V; I_{OL} = 100\mu\text{A}$		0.2	V
		$V_{CC} = 1.65V; I_{OL} = 6\text{mA}$		0.3	
$I_I$	Input Leakage Current	$V_{CC} = 1.65V; 0 \leq V_I \leq 3.6V$		$\pm 5.0$	$\mu\text{A}$
$I_{OZ}$	3-State Output Current	$V_{CC} = 1.65 - 1.95V; 0 \leq V_O \leq 3.6V; V_I = V_{IH}$ or $V_{IL}$		$\pm 10$	$\mu\text{A}$
$I_{OFF}$	Power-Off Leakage Current	$V_{CC} = 0V; 0V \leq (V_I, V_O) \leq 3.6V$		10	$\mu\text{A}$
$I_{CC}$	Quiescent Supply Current	$V_{CC} = 1.65 - 1.95V; V_I = V_{CC}$ or GND		20	$\mu\text{A}$
		$V_{CC} = 1.65 - 1.95V; V_{CC} \leq (V_I, V_O) \leq 3.6V$		$\pm 20$	

**AC CHARACTERISTICS** (Note 4.;  $t_R = t_F = 2.0\text{ns}$ ;  $C_L = 30\text{pF}$ ;  $R_L = 500\Omega$ )

Symbol	Parameter	Waveform	Limits					Unit
			$T_A = -40^\circ\text{C to } +85^\circ\text{C}$					
			$V_{CC} = 3.0V \text{ to } 3.6V$		$V_{CC} = 2.3V \text{ to } 2.7V$		$V_{CC} = 1.65 - 1.95V$	
			Min	Max	Min	Max	Max	
$t_{PLH}$ $t_{PHL}$	Propagation Delay Input to Output	1	0.8 0.8	2.5 2.5	1.0 1.0	3.0 3.0	6.0 6.0	ns
$t_{PZH}$ $t_{PZL}$	Output Enable Time to High and Low Level	2	0.8 0.8	3.5 3.5	1.0 1.0	4.1 4.1	8.2 8.2	
$t_{PHZ}$ $t_{PLZ}$	Output Disable Time From High and Low Level	2	0.8 0.8	3.5 3.5	1.0 1.0	3.8 3.8	6.8 6.8	ns
$t_{OSHL}$ $t_{OSLH}$	Output-to-Output Skew (Note 5.)			0.5 0.5		0.5 0.5	0.75 0.75	

- These AC parameters are preliminary and may be modified prior to release. For  $C_L = 50\text{pF}$ , add approximately 300ps to the AC maximum specification.
- Skew is defined as the absolute value of the difference between the actual propagation delay for any two separate outputs of the same device. The specification applies to any outputs switching in the same direction, either HIGH-to-LOW ( $t_{OSHL}$ ) or LOW-to-HIGH ( $t_{OSLH}$ ); parameter guaranteed by design.

# MC74VCX16240

## DYNAMIC SWITCHING CHARACTERISTICS

Symbol	Characteristic	Condition	T <sub>A</sub> = +25°C	
			Typ	Unit
V <sub>OLP</sub>	Dynamic LOW Peak Voltage (Note 6.)	V <sub>CC</sub> = 1.8V, C <sub>L</sub> = 30pF, V <sub>IH</sub> = V <sub>CC</sub> , V <sub>IL</sub> = 0V	0.25	V
		V <sub>CC</sub> = 2.5V, C <sub>L</sub> = 30pF, V <sub>IH</sub> = V <sub>CC</sub> , V <sub>IL</sub> = 0V	0.6	
		V <sub>CC</sub> = 3.3V, C <sub>L</sub> = 30pF, V <sub>IH</sub> = V <sub>CC</sub> , V <sub>IL</sub> = 0V	0.8	
V <sub>OLV</sub>	Dynamic LOW Valley Voltage (Note 6.)	V <sub>CC</sub> = 1.8V, C <sub>L</sub> = 30pF, V <sub>IH</sub> = V <sub>CC</sub> , V <sub>IL</sub> = 0V	-0.25	V
		V <sub>CC</sub> = 2.5V, C <sub>L</sub> = 30pF, V <sub>IH</sub> = V <sub>CC</sub> , V <sub>IL</sub> = 0V	-0.6	
		V <sub>CC</sub> = 3.3V, C <sub>L</sub> = 30pF, V <sub>IH</sub> = V <sub>CC</sub> , V <sub>IL</sub> = 0V	-0.8	
V <sub>OHV</sub>	Dynamic HIGH Valley Voltage (Note 7.)	V <sub>CC</sub> = 1.8V, C <sub>L</sub> = 30pF, V <sub>IH</sub> = V <sub>CC</sub> , V <sub>IL</sub> = 0V	1.5	V
		V <sub>CC</sub> = 2.5V, C <sub>L</sub> = 30pF, V <sub>IH</sub> = V <sub>CC</sub> , V <sub>IL</sub> = 0V	1.9	
		V <sub>CC</sub> = 3.3V, C <sub>L</sub> = 30pF, V <sub>IH</sub> = V <sub>CC</sub> , V <sub>IL</sub> = 0V	2.2	

- Number of outputs defined as "n". Measured with "n-1" outputs switching from HIGH-to-LOW or LOW-to-HIGH. The remaining output is measured in the LOW state.
- Number of outputs defined as "n". Measured with "n-1" outputs switching from HIGH-to-LOW or LOW-to-HIGH. The remaining output is measured in the HIGH state.

## CAPACITIVE CHARACTERISTICS

Symbol	Parameter	Condition	Typical	Unit
C <sub>IN</sub>	Input Capacitance	Note 8.	6	pF
C <sub>OUT</sub>	Output Capacitance	Note 8.	7	pF
C <sub>PD</sub>	Power Dissipation Capacitance	Note 8., 10MHz	20	pF

- V<sub>CC</sub> = 1.8, 2.5 or 3.3V; V<sub>I</sub> = 0V or V<sub>CC</sub>.

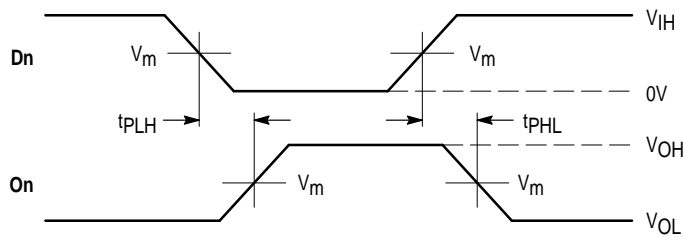

**WAVEFORM 1 - PROPAGATION DELAYS**  
 $t_R = t_F = 2.0\text{ns}$ , 10% to 90%;  $f = 1\text{MHz}$ ;  $t_{WJ} = 500\text{ns}$

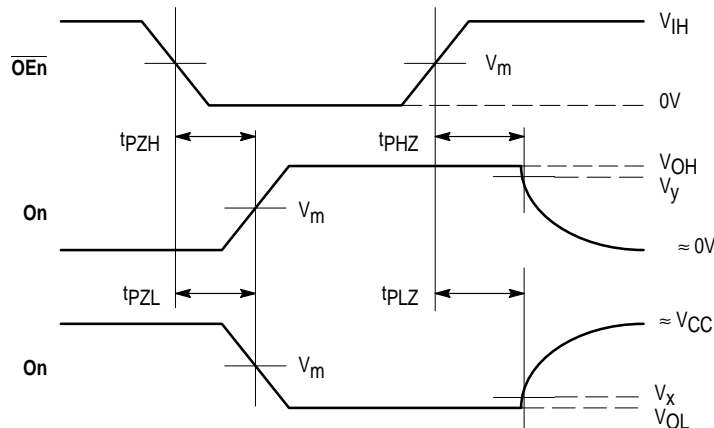

**WAVEFORM 2 - OUTPUT ENABLE AND DISABLE TIMES**  
 $t_R = t_F = 2.0\text{ns}$ , 10% to 90%;  $f = 1\text{MHz}$ ;  $t_{WJ} = 500\text{ns}$

**Figure 3. AC Waveforms**

Symbol	V <sub>CC</sub>		
	3.3V ±0.3V	2.5V ±0.2V	1.8V ±0.15V
V <sub>IH</sub>	2.7V	V <sub>CC</sub>	V <sub>CC</sub>
V <sub>m</sub>	1.5V	V <sub>CC</sub> /2	V <sub>CC</sub> /2
V <sub>x</sub>	V <sub>OL</sub> + 0.3V	V <sub>OL</sub> + 0.15V	V <sub>OL</sub> + 0.15V
V <sub>y</sub>	V <sub>OH</sub> - 0.3V	V <sub>OH</sub> - 0.15V	V <sub>OH</sub> - 0.15V

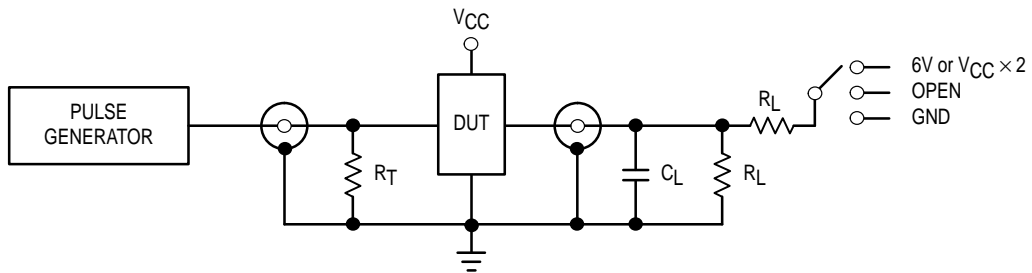

TEST	SWITCH
t <sub>PLH</sub> , t <sub>PHL</sub>	Open
t <sub>PZL</sub> , t <sub>PLZ</sub>	6V at V <sub>CC</sub> = 3.3 ±0.3V; V <sub>CC</sub> × 2 at V <sub>CC</sub> = 2.5 ±0.2V; 1.8 ±0.15V
t <sub>PZH</sub> , t <sub>PHZ</sub>	GND

C<sub>L</sub> = 30pF or equivalent (Includes jig and probe capacitance)  
R<sub>L</sub> = 500Ω or equivalent  
R<sub>T</sub> = Z<sub>OUT</sub> of pulse generator (typically 50Ω)

Figure 4. Test Circuit

OUTLINE DIMENSIONS

DT SUFFIX  
 PLASTIC TSSOP PACKAGE  
 CASE 1201-01  
 ISSUE A

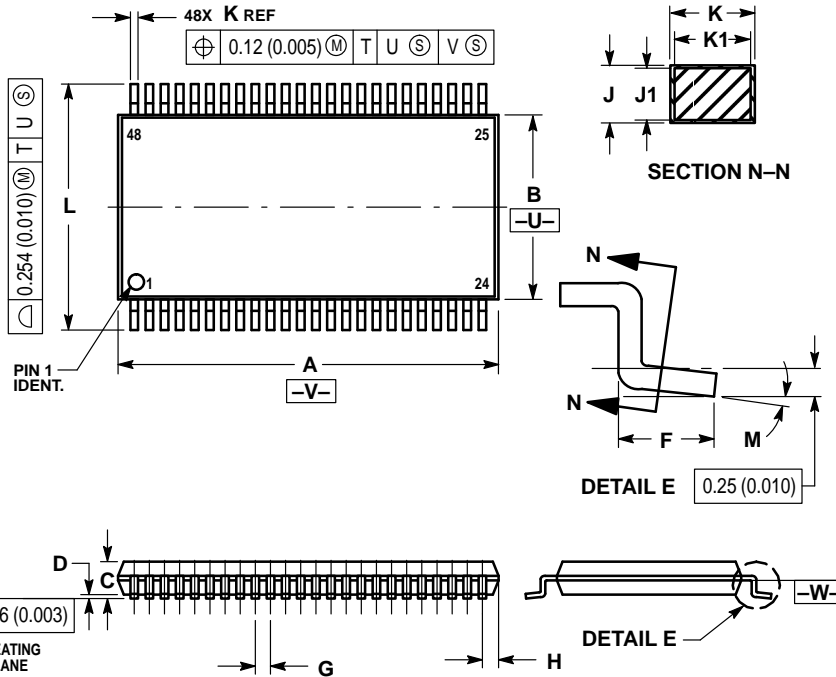

- NOTES:
1. DIMENSIONING AND TOLERANCING PER ANSI Y14.5M, 1982.
  2. CONTROLLING DIMENSION: MILLIMETER.
  3. DIMENSIONS A AND B DO NOT INCLUDE MOLD FLASH, PROTRUSIONS OR GATE BURRS. MOLD FLASH OR GATE BURRS SHALL NOT EXCEED 0.15 (0.006) PER SIDE.
  4. DIMENSION K DOES NOT INCLUDE DAMBAR PROTRUSION. ALLOWABLE DAMBAR PROTRUSION SHALL BE 0.08 (0.003) TOTAL IN EXCESS OF THE K DIMENSION AT MAXIMUM MATERIAL CONDITION.
  5. TERMINAL NUMBERS ARE SHOWN FOR REFERENCE ONLY.
  6. DIMENSIONS A AND B ARE TO BE DETERMINED AT DATUM PLANE -W-.

DIM	MILLIMETERS		INCHES	
	MIN	MAX	MIN	MAX
A	12.40	12.60	0.488	0.496
B	6.00	6.20	0.236	0.244
C	—	1.10	—	0.043
D	0.05	0.15	0.002	0.006
F	0.50	0.75	0.020	0.030
G	0.50 BSC		0.0197 BSC	
H	0.37	—	0.015	—
J	0.09	0.20	0.004	0.008
J1	0.09	0.16	0.004	0.006
K	0.17	0.27	0.007	0.011
K1	0.17	0.23	0.007	0.009
L	7.95	8.25	0.313	0.325
M	0°	8°	0°	8°

Motorola reserves the right to make changes without further notice to any products herein. Motorola makes no warranty, representation or guarantee regarding the suitability of its products for any particular purpose, nor does Motorola assume any liability arising out of the application or use of any product or circuit, and specifically disclaims any and all liability, including without limitation consequential or incidental damages. "Typical" parameters which may be provided in Motorola data sheets and/or specifications can and do vary in different applications and actual performance may vary over time. All operating parameters, including "Typicals" must be validated for each customer application by customer's technical experts. Motorola does not convey any license under its patent rights nor the rights of others. Motorola products are not designed, intended, or authorized for use as components in systems intended for surgical implant into the body, or other applications intended to support or sustain life, or for any other application in which the failure of the Motorola product could create a situation where personal injury or death may occur. Should Buyer purchase or use Motorola products for any such unintended or unauthorized application, Buyer shall indemnify and hold Motorola and its officers, employees, subsidiaries, affiliates, and distributors harmless against all claims, costs, damages, and expenses, and reasonable attorney fees arising out of, directly or indirectly, any claim of personal injury or death associated with such unintended or unauthorized use, even if such claim alleges that Motorola was negligent regarding the design or manufacture of the part. Motorola and are registered trademarks of Motorola, Inc. Motorola, Inc. is an Equal Opportunity/Affirmative Action Employer.

Mfax is a trademark of Motorola, Inc.

How to reach us:

USA/EUROPE/Locations Not Listed: Motorola Literature Distribution;  
 P.O. Box 5405, Denver, Colorado 80217. 1-303-675-2140 or 1-800-441-2447

JAPAN: Motorola Japan Ltd.; SPD, Strategic Planning Office, 141,  
 4-32-1 Nishi-Gotanda, Shinagawa-ku, Tokyo, Japan. 81-3-5487-8488

Customer Focus Center: 1-800-521-6274

Mfax™: RMFAX0@email.sps.mot.com – TOUCHTONE 1-602-244-6609  
 Motorola Fax Back System – US & Canada ONLY 1-800-774-1848  
 – http://sps.motorola.com/mfax/

ASIA/PACIFIC: Motorola Semiconductors H.K. Ltd.; 8B Tai Ping Industrial Park,  
 51 Ting Kok Road, Tai Po, N.T., Hong Kong. 852-26629298

HOME PAGE: http://motorola.com/sps/

