

# OPA685

For most current data sheet and other product information, visit [www.burr-brown.com](http://www.burr-brown.com)

## SpeedPlus™ Ultra-Wideband, Current-Feedback OPERATIONAL AMPLIFIER With Disable

### FEATURES

- GAIN = +2 BANDWIDTH (900MHz)
- GAIN = +8 BANDWIDTH (420MHz)
- OUTPUT VOLTAGE SWING:  $\pm 3.6V$
- ULTRA-HIGH SLEW RATE:  $4200V/\mu s$
- 3RD-ORDER INTERCEPT:  $> 40dBm$  ( $f < 50MHz$ )
- LOW POWER: 129mW
- LOW DISABLED POWER: 3mW

### APPLICATIONS

- LOW COST PRECISION IF AMPLIFIER
- CABLE MODEM UPSTREAM DRIVER
- BROADBAND VIDEO LINE DRIVER
- VERY WIDEBAND ADC BUFFER
- PORTABLE INSTRUMENTS
- ACTIVE FILTERS
- ARB WAVEFORM OUTPUT DRIVER

### DESCRIPTION

The OPA685 is a very high bandwidth, current-feedback op amp that combines exceptional  $4200V/\mu s$  slew rate and low input voltage noise to deliver a precision low cost, high dynamic range Intermediate Frequency (IF) amplifier. Optimized for high gain operation, the OPA685 is ideally suited to buffering Surface Acoustic Wave (SAW) filters in an IF strip or delivering high output power at low distortion for cable modem upstream line drivers. Even higher bandwidth at lower gains gives a 900MHz video line driver for high resolution workstation graphics.

The OPA685's low 12.9mA supply current is precisely trimmed at  $+25^{\circ}C$ . This trim, along with a low temperature drift, guarantees low system power over-

temperature. System power may be further reduced using the optional disable control pin. Leaving this pin open, or holding it HIGH, gives normal operation. If pulled LOW, the OPA685 supply current drops to less than  $320\mu A$ . This power-savings feature, along with exceptional single  $+5V$  operation, and ultra-small SOT23-6 packaging, make the OPA685 ideal for portable communications requirements.

### OPA685 RELATED PRODUCTS

SINGLES	DUALS
OPA658	OPA2658
OPA681	OPA2681
OPA682	OPA2682

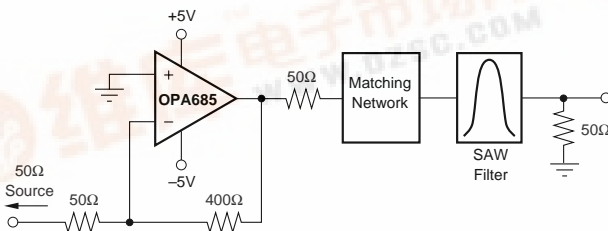

Low Distortion, 12dB Gain SAW Driver

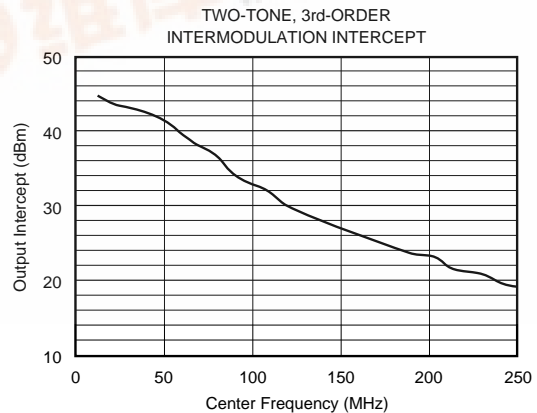

# SPECIFICATIONS: $V_S = \pm 5V$

$R_F = 402\Omega$ ,  $R_L = 100\Omega$ , and  $G = +8$ , (Figure 1 for AC performance only), unless otherwise noted.

PARAMETER	CONDITIONS	OPA685U, N					MIN/ MAX	TEST LEVEL <sup>(1)</sup>
		TYP	GUARANTEED					
		+25°C	+25°C <sup>(2)</sup>	0°C to 70°C <sup>(3)</sup>	-40°C to +85°C <sup>(3)</sup>	UNITS		
<b>AC PERFORMANCE (Figure 1)</b>								
Small-Signal Bandwidth ( $V_O = 0.5V_{p-p}$ )	$G = +1$ , $R_F = 523\Omega$	1200				MHz	typ	C
	$G = +2$ , $R_F = 511\Omega$	900				MHz	typ	C
	$G = +8$ , $R_F = 402\Omega$	420	360	350	320	MHz	min	B
	$G = +16$ , $R_F = 249\Omega$	340				MHz	typ	C
Bandwidth for 0.1dB Gain Flatness	$G = +2$ , $V_O = 0.5V_{p-p}$ , $R_F = 523\Omega$	350	150	80	70	MHz	min	B
Peaking at a Gain of +1	$R_F = 523\Omega$ , $V_O = 0.5V_{p-p}$	3	4.5	5	6.0	dB	max	B
Large Signal Bandwidth	$G = +8$ , $V_O = 4V_{p-p}$	350				MHz	typ	C
Slew Rate	$G = -8$ , $V_O = 4V$ Step	4200	3000	2500	2200	V/ $\mu s$	min	B
	$G = +8$ , $V_O = 4V$ Step	2900	2400	2400	2100	V/ $\mu s$	min	B
Rise/Fall Time	$G = +8$ , $V_O = 0.5V$ Step	0.7				ns	typ	C
	$G = +8$ , $V_O = 4V$ Step	1.0				ns	typ	C
Settling Time to 0.02%	$G = +8$ , $V_O = 2V$ Step	4				ns	typ	C
0.1%	$G = +8$ , $V_O = 2V$ Step	3				ns	typ	C
Harmonic Distortion	$G = +8$ , $f = 10MHz$ , $V_O = 2V_{p-p}$							
2nd Harmonic	$R_L = 100\Omega$	-66	-59	-56	-53	dBc	max	B
	$R_L \geq 500\Omega$	-75	-69	-66	-63	dBc	max	B
3rd Harmonic	$R_L = 100\Omega$	-90	-83	-77	-74	dBc	max	B
	$R_L \geq 500\Omega$	-84	-78	-76	-75	dBc	max	B
Input Voltage Noise	$f > 1MHz$	1.7	1.8	2.2	2.3	nV/ $\sqrt{Hz}$	max	B
Non-Inverting Input Current Noise	$f > 1MHz$	13	15	15	15	pA/ $\sqrt{Hz}$	max	B
Inverting Input Current Noise	$f > 1MHz$	19	22	22	22	pA/ $\sqrt{Hz}$	max	B
Differential Gain	$G = +2$ , NTSC, $V_O = 1.4V_{p-p}$ , $R_L = 150\Omega$	0.10				%	typ	C
Differential Phase	$G = +2$ , NTSC, $V_O = 1.4V_{p-p}$ , $R_L = 150\Omega$	0.01				deg	typ	C
<b>DC PERFORMANCE<sup>(4)</sup></b>								
Open-Loop Transimpedance Gain ( $Z_{OL}$ )	$V_O = 0V$ , $R_L = 100\Omega$	42	<b>26</b>	24	23	k $\Omega$	min	A
Input Offset Voltage	$V_{CM} = 0V$	$\pm 1.7$	<b><math>\pm 3.5</math></b>	$\pm 5$	$\pm 7$	mV	max	A
Average Offset Voltage Drift	$V_{CM} = 0V$			+35	+40	$\mu V/^\circ C$	max	B
Non-Inverting Input Bias Current	$V_{CM} = 0V$	+56	<b>+90</b>	$\pm 100$	$\pm 130$	$\mu A$	max	A
Average Non-Inverting Input Bias Current Drift	$V_{CM} = 0V$			-530	-570	nA/ $^\circ C$	max	B
Inverting Input Bias Current	$V_{CM} = 0V$	$\pm 10$	<b><math>\pm 100</math></b>	$\pm 120$	$\pm 150$	$\mu A$	max	A
Average Inverting Input Bias Current Drift	$V_{CM} = 0V$			-500	-560	nA/ $^\circ C$	max	B
<b>INPUT</b>								
Common-Mode Input Range <sup>(5)</sup> (CMIR)		$\pm 3.4$	<b><math>\pm 3.2</math></b>	$\pm 3.1$	$\pm 3.0$	V	min	A
Common-Mode Rejection Ratio (CMRR)	$V_{CM} = 0V$	54	<b>49</b>	48	48	dB	min	A
Non-Inverting Input Impedance		87    2				k $\Omega$    pF	typ	C
Inverting Input Resistance ( $R_i$ )	Open-Loop	19				$\Omega$	typ	C
<b>OUTPUT</b>								
Voltage Output Swing	No Load	$\pm 4.1$	<b><math>\pm 3.9</math></b>	$\pm 3.8$	$\pm 3.8$	V	min	A
	100 $\Omega$ Load	$\pm 3.6$	<b><math>\pm 3.3</math></b>	$\pm 3.2$	$\pm 3.1$	V	min	A
Current Output, Sourcing	$V_O = 0$	+130	<b>+90</b>	+75	+70	mA	min	A
Current Output, Sinking	$V_O = 0$	-90	<b>-60</b>	-50	-45	mA	min	A
Closed-Loop Output Impedance	$G = +8$ , $f = 100kHz$	0.2				$\Omega$	typ	C
<b>DISABLE (Disabled Low)</b>								
Power Down Supply Current ( $+V_S$ )	$V_{DIS} = 0$	-320				$\mu A$	typ	C
Disable Time		100				ns	typ	C
Enable Time		100				ns	typ	C
Off Isolation	$G = +8$ , 10MHz	70				dB	typ	C
Output Capacitance in Disable		3				pF	typ	C
Turn On Glitch	$G = +2$ , $R_L = 150\Omega$ , $V_{IN} = 0$	$\pm 160$				mV	typ	C
Turn Off Glitch	$G = +2$ , $R_L = 150\Omega$ , $V_{IN} = 0$	$\pm 20$				mV	typ	C
Enable Voltage		3.3	<b>3.5</b>	3.6	3.7	V	min	A
Disable Voltage		1.8	<b>1.7</b>	1.6	1.5	V	max	A
Control Pin Input Bias Current ( $\overline{DIS}$ )	$V_{DIS} = 0$	115	<b>160</b>	160	160	$\mu A$	max	A
<b>POWER SUPPLY</b>								
Specified Operating Voltage		$\pm 5$				V	typ	C
Maximum Operating Voltage Range			<b><math>\pm 6</math></b>	$\pm 6$	$\pm 6$	V	max	A
Max Quiescent Current	$V_S = \pm 5V$	12.9	<b>13.5</b>	13.5	13.5	mA	max	A
Min Quiescent Current	$V_S = \pm 5V$	12.9	<b>12.5</b>	11.9	11.2	mA	min	A
Power Supply Rejection Ratio (-PSRR)	Input Referred	55	49	47	46	dB	typ	A
<b>TEMPERATURE RANGE</b>								
Specification: U, N		-40 to +85				$^\circ C$	typ	C
Thermal Resistance, $\theta_{JA}$	Junction-to-Ambient							
U SO-8		125				$^\circ C/W$	typ	C
N SOT23-6		150				$^\circ C/W$	typ	C

NOTES: (1) Test levels: (A) 100% tested at 25°C. Over temperature limits by characterization and simulation. (B) Limits set by characterization and simulation. (C) Typical value only for information. (2) Junction temperature = ambient for 25°C guaranteed specifications. (3) Junction temperature = ambient at low temperature limit; junction temperature = ambient +23°C at high temperature limit for over temperature guaranteed specifications. (4) Current is considered positive out-of-node.  $V_{CM}$  is the input common-mode voltage. (5) Tested < 3dB below minimum specified CMRR at  $\pm$  CMIR limits.

# SPECIFICATIONS: $V_S = +5V$

$R_F = 348\Omega$ ,  $R_L = 100\Omega$  to  $V_S/2$ , and  $G = +8$ , (Figure 3 for AC performance only), unless otherwise noted.

PARAMETER	CONDITIONS	OPA685U, N						TEST LEVEL <sup>(1)</sup>
		TYP	GUARANTEED				MIN/ MAX	
		+25°C	+25°C <sup>(2)</sup>	0°C to 70°C <sup>(3)</sup>	-40°C to +85°C <sup>(3)</sup>	UNITS		
<b>AC PERFORMANCE (Figure 3)</b>								
Small-Signal Bandwidth ( $V_O = 0.5V_{p-p}$ )	$G = +1$ , $R_F = 511\Omega$	600				MHz	typ	C
	$G = +2$ , $R_F = 487\Omega$	450				MHz	min	B
	$G = +8$ , $R_F = 348\Omega$	350	240	220	200	MHz	typ	C
	$G = +16$ , $R_F = 162\Omega$	250				MHz	typ	C
Bandwidth for 0.1dB Gain Flatness	$G = +2$ , $V_O < 0.5V_{p-p}$ , $R_F = 487\Omega$	140	80	70	60	MHz	min	B
Peaking at a Gain of +1	$R_F = 511\Omega$ , $V_O < 0.5V_{p-p}$	0.4	1.0	1.5	1.5	dB	max	B
Large Signal Bandwidth	$G = +8$ , $V_O = 2V_{p-p}$	350				MHz	typ	C
Slew Rate	$G = +8$ , 2V Step	1900	1300	1200	1100	V/ $\mu$ s	min	B
Rise/Fall Time	$G = +8$ , $V_O = 0.5V$ Step	0.8				ns	typ	C
	$G = +8$ , $V_O = 2V$ Step	1.0				ns	typ	C
Settling Time to 0.02%	$G = +8$ , $V_O = 2V$ Step	9				ns	typ	C
0.1%	$G = +8$ , $V_O = 2V$ Step	7				ns	typ	C
Harmonic Distortion	$G = +8$ , $f = 10MHz$ , $V_O = 2V_{p-p}$							
2nd Harmonic	$R_L = 100\Omega$ to $V_S/2$	-60	-54	-53	-52	dBc	max	B
	$R_L \geq 500\Omega$ to $V_S/2$	-68	-60	-59	-58	dBc	max	B
3rd Harmonic	$R_L = 100\Omega$ to $V_S/2$	-58	-51	-50	-50	dBc	max	B
	$R_L \geq 500\Omega$ to $V_S/2$	-60	-55	-54	-54	dBc	max	B
Input Voltage Noise	$f > 1MHz$	1.7	1.8	2.2	2.2	nV/ $\sqrt{Hz}$	max	B
Non-Inverting Input Current Noise	$f > 1MHz$	13	15	15	15	pA/ $\sqrt{Hz}$	max	B
Inverting Input Current Noise	$f > 1MHz$	19	22	22	22	pA/ $\sqrt{Hz}$	max	B
<b>DC PERFORMANCE<sup>(4)</sup></b>								
Open-Loop Transimpedance Gain ( $Z_{OL}$ )	$V_O = V_S/2$ , $R_L = 100\Omega$ to $V_S/2$	40	<b>25</b>	23	20	k $\Omega$	min	A
Input Offset Voltage	$V_{CM} = V_S/2$	$\pm 1$	$\pm 3$	$\pm 3.5$	$\pm 4.0$	mV	max	A
Average Offset Voltage Drift	$V_{CM} = V_S/2$			12	15	$\mu V/^\circ C$	max	B
Non-Inverting Input Bias Current	$V_{CM} = V_S/2$	+40	<b>+110</b>	$\pm 120$	$\pm 150$	$\mu A$	max	A
Average Non-Inverting Input Bias Current Drift	$V_{CM} = V_S/2$			-550	-650	nA/ $^\circ C$	max	B
Inverting Input Bias Current	$V_{CM} = V_S/2$	$\pm 50$	$\pm 100$	$\pm 120$	$\pm 150$	$\mu A$	max	A
Average Inverting Input Bias Current Drift	$V_{CM} = V_S/2$			-550	-650	nA/ $^\circ C$	max	B
<b>INPUT</b>								
Least Positive Input Voltage <sup>(5)</sup>		1.7	<b>1.8</b>	1.9	2.0	V	max	A
Most Positive Input Voltage <sup>(5)</sup>		3.3	<b>3.2</b>	3.1	3.0	V	min	A
Common-Mode Rejection Ratio (CMRR)	$V_{CM} = V_S/2$	54	<b>48</b>	47	47	dB	min	A
Non-Inverting Input Impedance		87    2				k $\Omega$    pF	typ	C
Inverting Input Resistance ( $R_i$ )	Open-Loop	23				$\Omega$	typ	C
<b>OUTPUT</b>								
Most Positive Output Voltage	No Load	4.1	<b>3.9</b>	3.7	3.5	V	min	A
	$R_L = 100\Omega$ to $V_S/2$	4.0	<b>3.8</b>	3.6	3.4	V	min	A
Least Positive Output Voltage	No Load	0.9	<b>1.1</b>	1.3	1.5	V	max	A
	$R_L = 100\Omega$ to $V_S/2$	1.0	<b>1.2</b>	1.4	1.6	V	max	A
Current Output, Sourcing	$V_O = V_S/2$	90	<b>62</b>	60	58	mA	min	A
Current Output, Sinking	$V_O = V_S/2$	-70	<b>-45</b>	-40	-38	mA	min	A
Closed-Loop Output Impedance	$G = +2$ , $f = 100kHz$	0.3				$\Omega$	typ	C
<b>DISABLE (Disable Low)</b>								
Power Down Supply Current ( $+V_S$ )	$V_{DIS} = 0$	-270				$\mu A$	typ	C
Disable Time		150				ns	typ	C
Enable Time		150				ns	typ	C
Off Isolation	$G = +8$ , 10MHz	70				dB	typ	C
Output Capacitance in Disable		3				pF	typ	C
Turn On Glitch	$G = +2$ , $R_L = 150\Omega$ , $V_{IN} = V_S/2$	$\pm 160$				mV	typ	C
Turn Off Glitch	$G = +2$ , $R_L = 150\Omega$ , $V_{IN} = V_S/2$	$\pm 20$				mV	typ	C
Enable Voltage		3.3	<b>3.5</b>	3.6	3.7	V	min	A
Disable Voltage		1.8	<b>1.7</b>	1.6	1.5	V	max	A
Control Pin Input Bias Current ( $\overline{DIS}$ )	$V_{DIS} = 0$	100				$\mu A$	typ	C
<b>POWER SUPPLY</b>								
Specified Single-Supply Operating Voltage		5				V	typ	C
Max Single-Supply Operating Voltage			<b>12</b>	12	12	V	max	A
Max Quiescent Current	$V_S = +5V$	10.7	<b>11.3</b>	11.3	11.3	mA	max	A
Min Quiescent Current	$V_S = +5V$	10.7	<b>9.0</b>	8.3	8.1	mA	min	A
Power Supply Rejection Ratio ( $-PSRR$ )	Input Referred	54	51	49	48	dB	min	A
<b>TEMPERATURE RANGE</b>								
Specification: U, N		-40 to +85				$^\circ C$	typ	C
Thermal Resistance, $\theta_{JA}$	Junction-to-Ambient							
U SO-8		125				$^\circ C/W$	typ	C
N SOT23-6		150				$^\circ C/W$	typ	C

NOTES: (1) Test levels: (A) 100% tested at 25°C. Over temperature limits by characterization and simulation. (B) Limits set by characterization and simulation. (C) Typical value only for information. (2) Junction temperature = ambient for 25°C guaranteed specifications. (3) Junction temperature = ambient at low temperature limit; junction temperature = ambient +23°C at high temperature limit for over temperature guaranteed specifications. (4) Current is considered positive out-of-node.  $V_{CM}$  is the input common-mode voltage. (5) Tested < 3dB below minimum specified CMRR at  $\pm CMIR$  limits.

## ABSOLUTE MAXIMUM RATINGS

Power Supply .....	±6.5VDC
Internal Power Dissipation .....	See Thermal Information
Differential Input Voltage .....	±1.2V
Input Voltage Range .....	±V <sub>S</sub>
Storage Temperature Range: U, N .....	-40°C to +125°C
Lead Temperature (soldering, 10s) .....	+300°C
Junction Temperature (T <sub>J</sub> ) .....	+175°C



## ELECTROSTATIC DISCHARGE SENSITIVITY

Electrostatic discharge can cause damage ranging from performance degradation to complete device failure. Burr-Brown Corporation recommends that all integrated circuits be handled and stored using appropriate ESD protection methods.

ESD damage can range from subtle performance degradation to complete device failure. Precision integrated circuits may be more susceptible to damage because very small parametric changes could cause the device not to meet published specifications.

## PIN CONFIGURATIONS

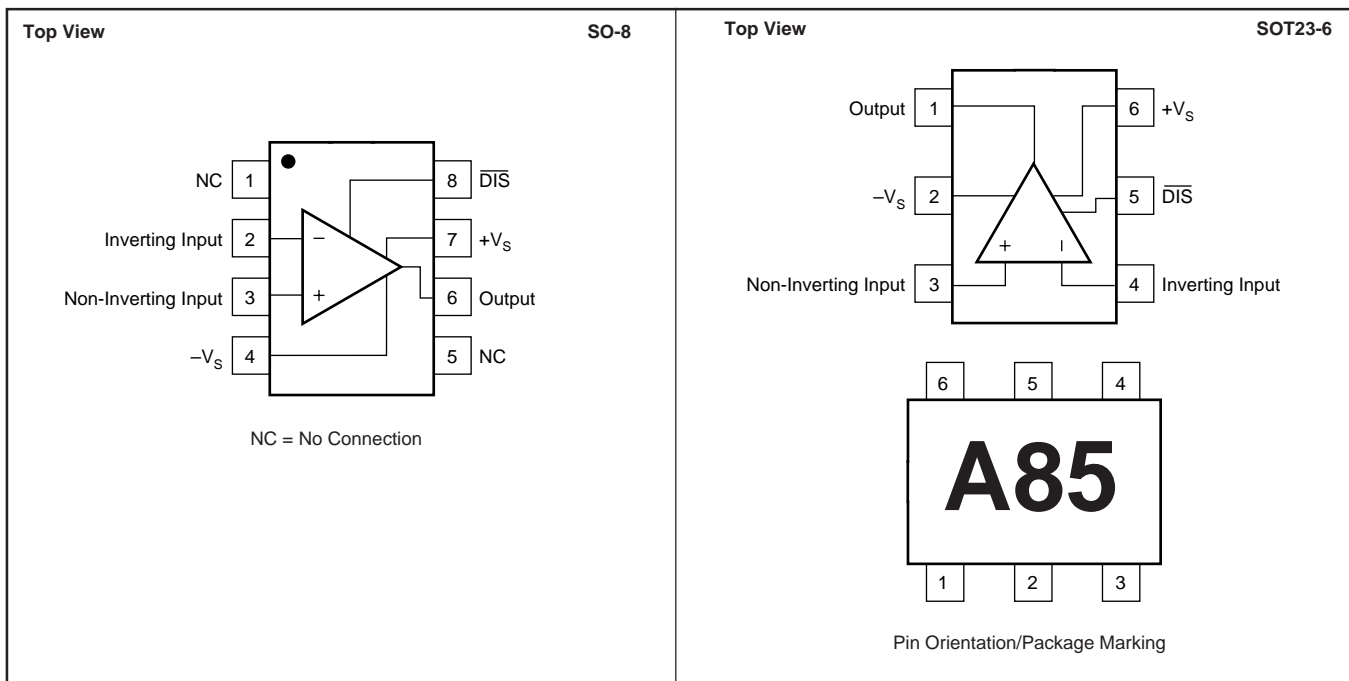

## PACKAGE/ORDERING INFORMATION

PRODUCT	PACKAGE	PACKAGE DRAWING NUMBER <sup>(1)</sup>	SPECIFIED TEMPERATURE RANGE	PACKAGE MARKING	ORDERING NUMBER	TRANSPORT MEDIA
OPA685U	SO-8 Surface Mount	182	-40°C to +85°C	OPA685U	OPA685U	Rails
"	"	"	"	"	OPA685U/2K5	Tape and Reel
OPA685N	SOT23-6	332	-40°C to +85°C	A85	OPA685N/250	Tape and Reel
"	"	"	"	"	OPA685N/3K	Tape and Reel

NOTES: (1) For detailed drawing and dimension table, please see end of data sheet, or Appendix C of Burr-Brown IC Data Book. (2) Models with a slash (/) are available only as Tape and Reel in the quantity indicated after the slash (e.g. /3K indicates 3000 devices per reel). Ordering 3000 pieces of the OPA685N/3K will get a single 3000-piece Tape and Reel. For detailed Tape and Reel mechanical information, refer to Appendix B of the Burr-Brown IC Data Book.

# TYPICAL PERFORMANCE CURVES: $V_S = \pm 5V$

$G = +8$ ,  $R_F = 402\Omega$ , and  $R_L = 100\Omega$ , unless otherwise noted.

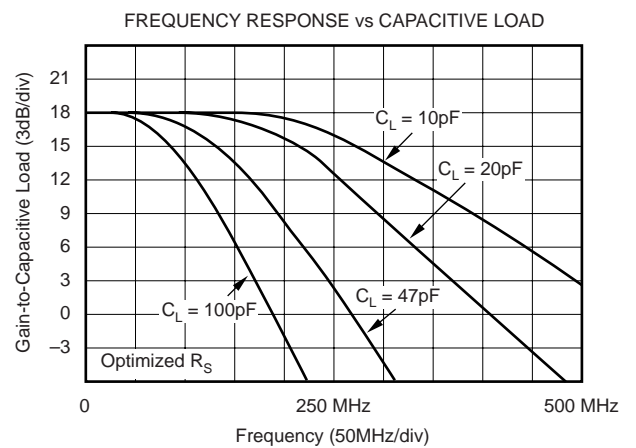
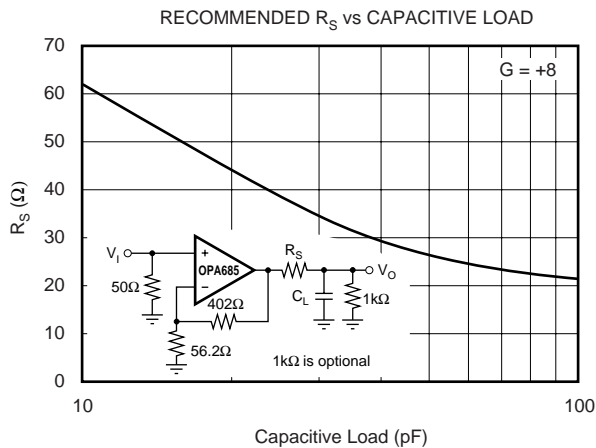
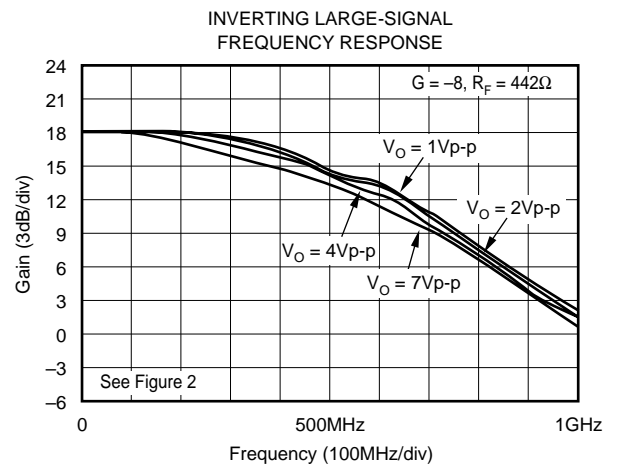
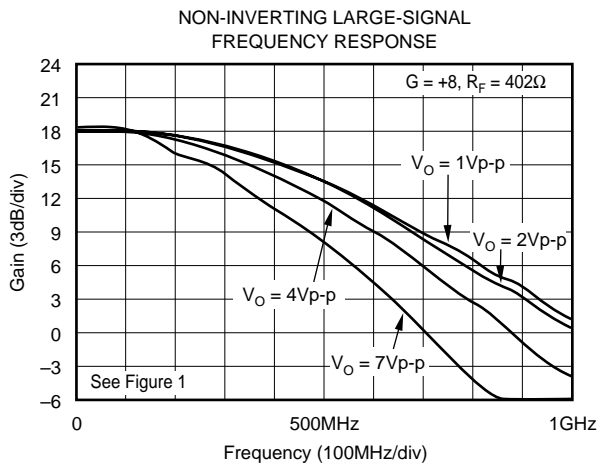
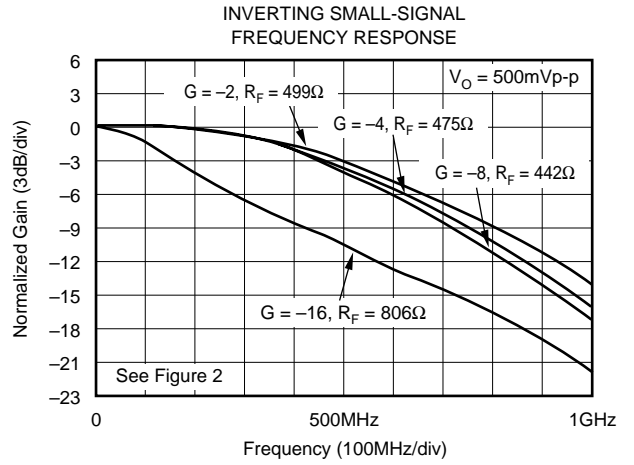
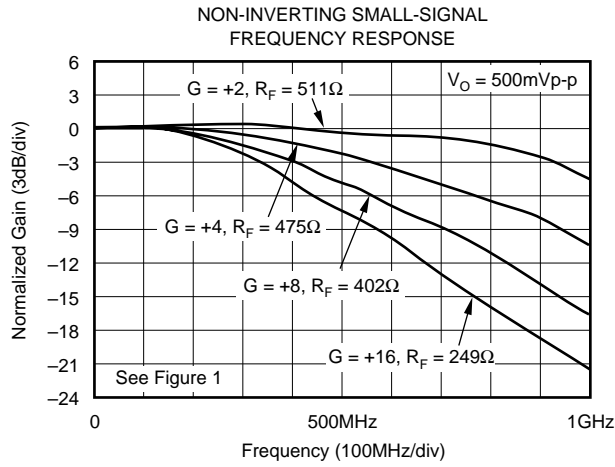

# TYPICAL PERFORMANCE CURVES: $V_S = \pm 5V$ (CONT)

$G = +8$ ,  $R_F = 402\Omega$ , and  $R_L = 100\Omega$ , unless otherwise noted. See Figure 1.

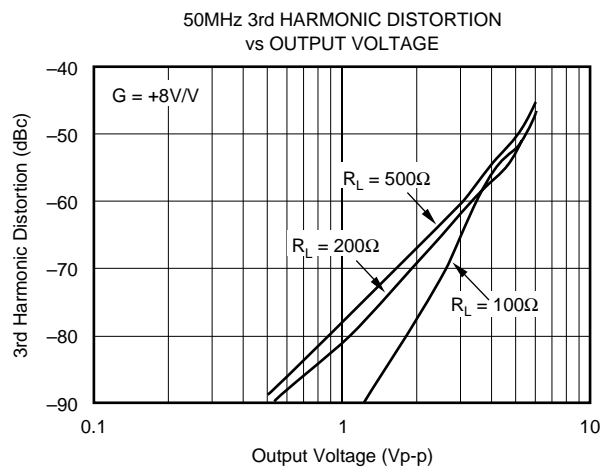
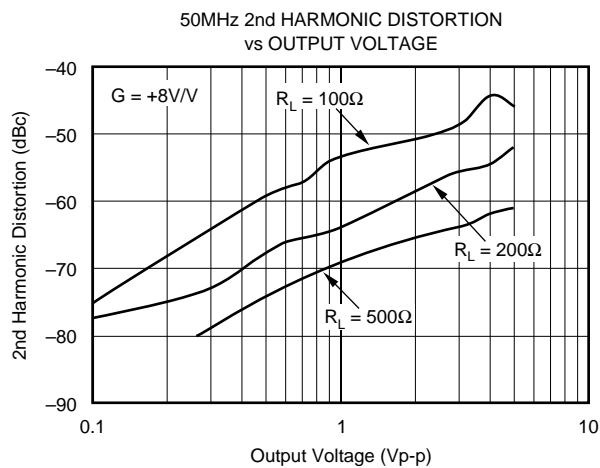
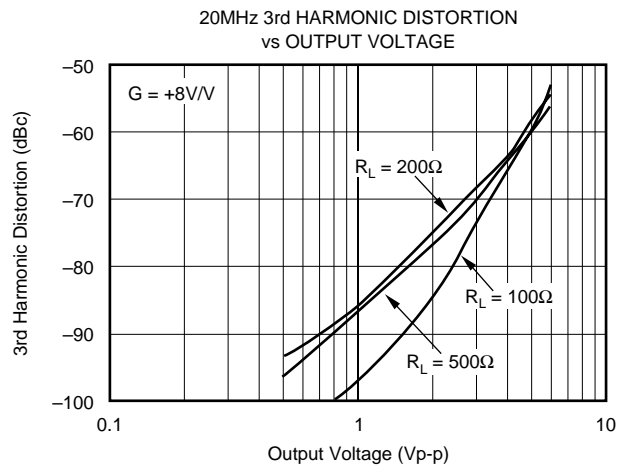
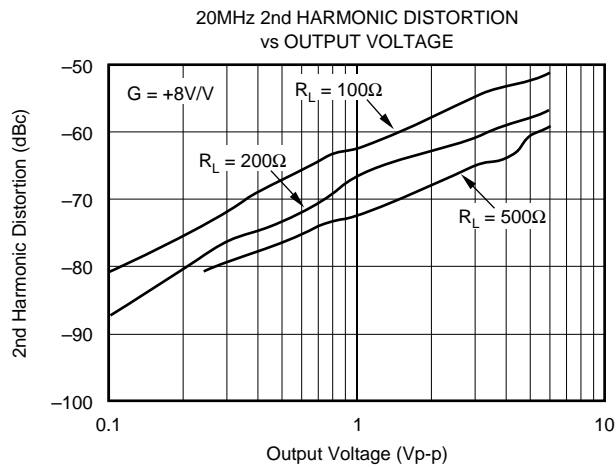
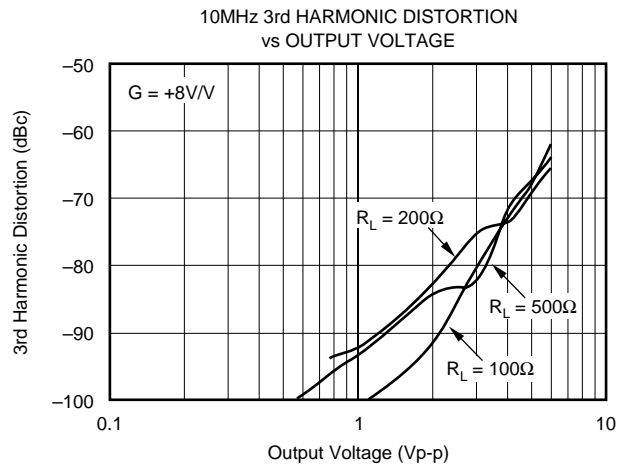
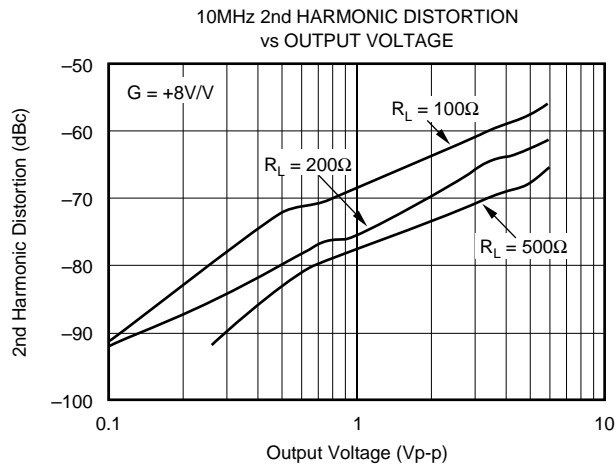

# TYPICAL PERFORMANCE CURVES: $V_S = \pm 5V$ (CONT)

$G = +8$ ,  $R_F = 402\Omega$ , and  $R_L = 100\Omega$ , unless otherwise noted. See Figure 1.

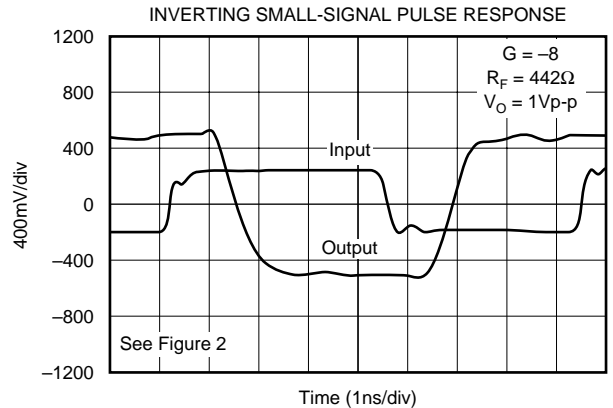
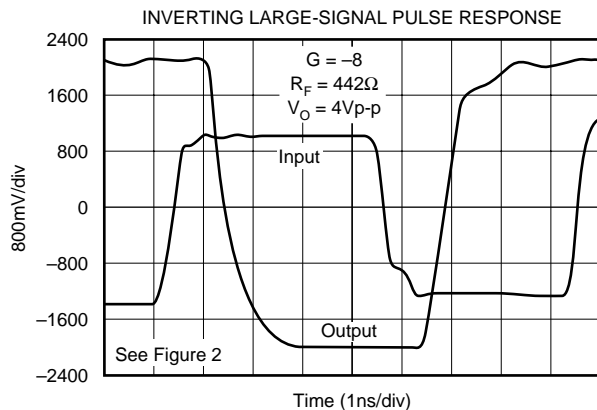
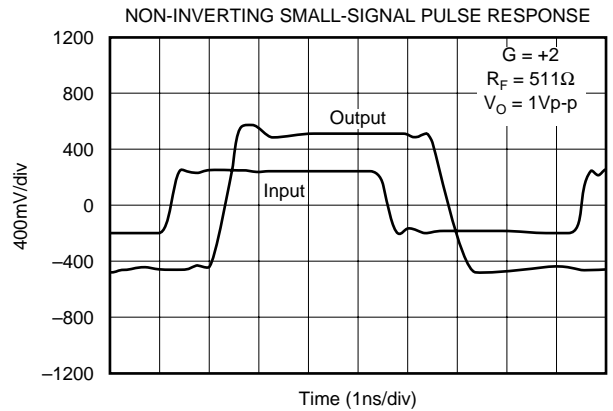
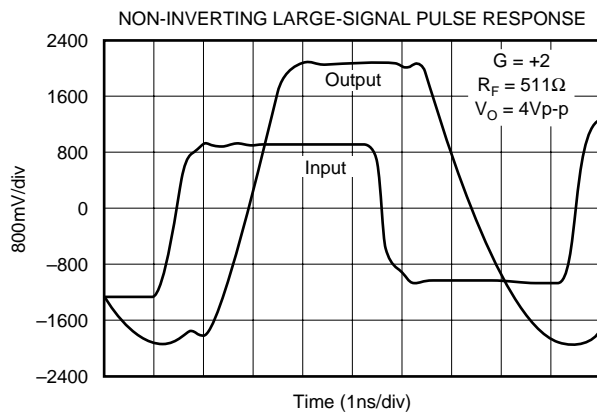
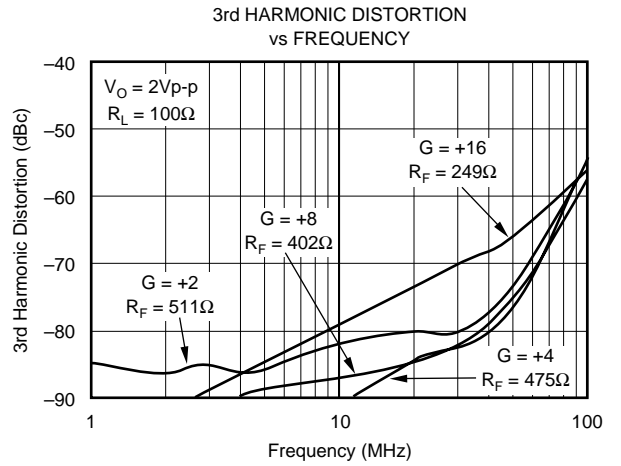
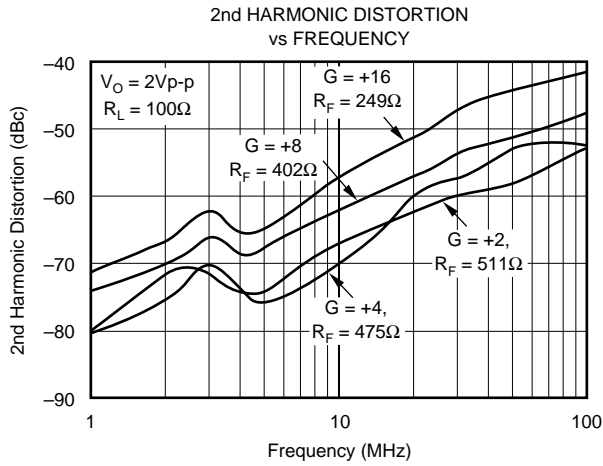

# TYPICAL PERFORMANCE CURVES: $V_S = \pm 5V$ (CONT)

$G = +8$ ,  $R_F = 402\Omega$ , and  $R_L = 100\Omega$ , unless otherwise noted.

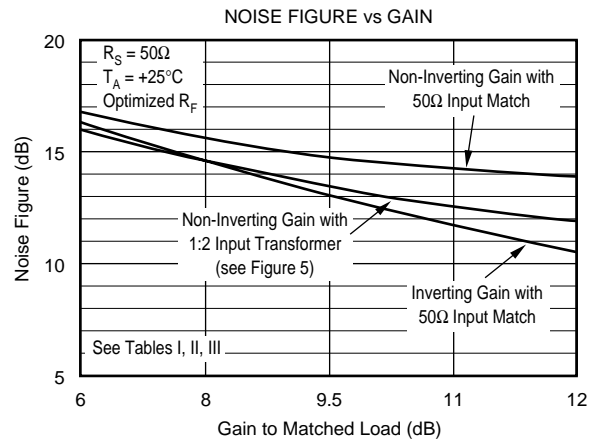
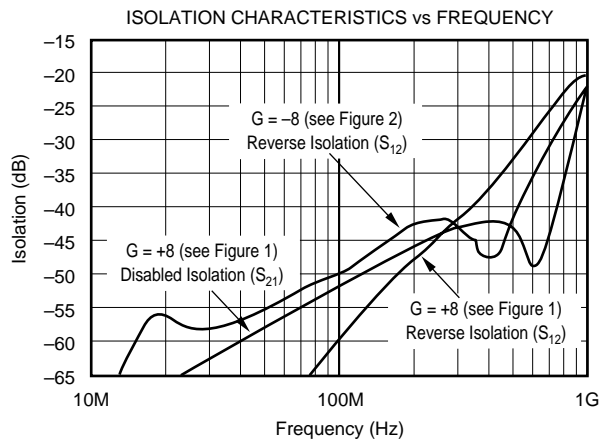
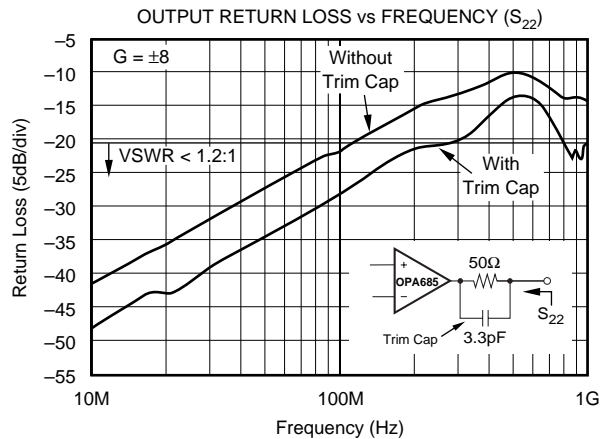
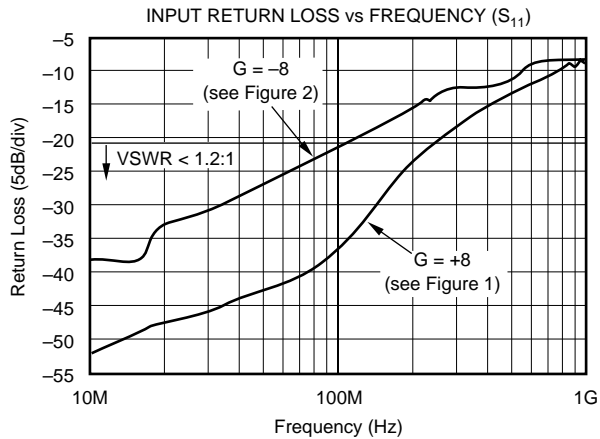
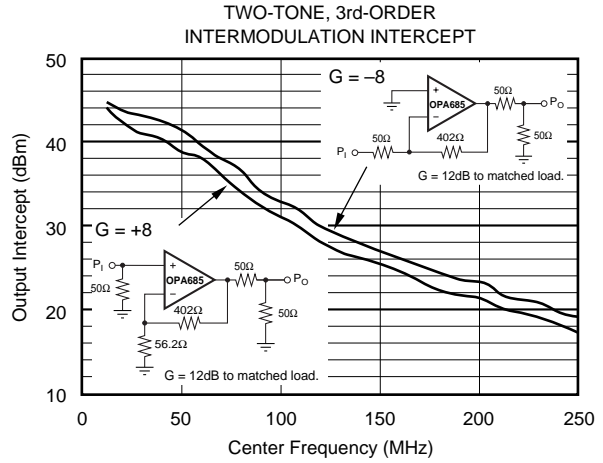
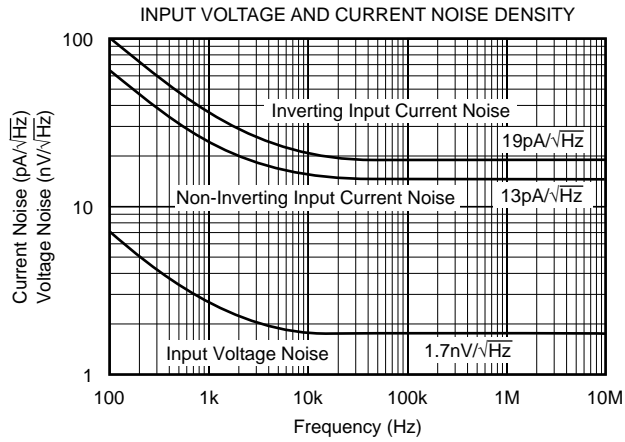



# TYPICAL PERFORMANCE CURVES: $V_S = \pm 5V$ (CONT)

$G = +8$ ,  $R_F = 402\Omega$ , and  $R_L = 100\Omega$ , unless otherwise noted.

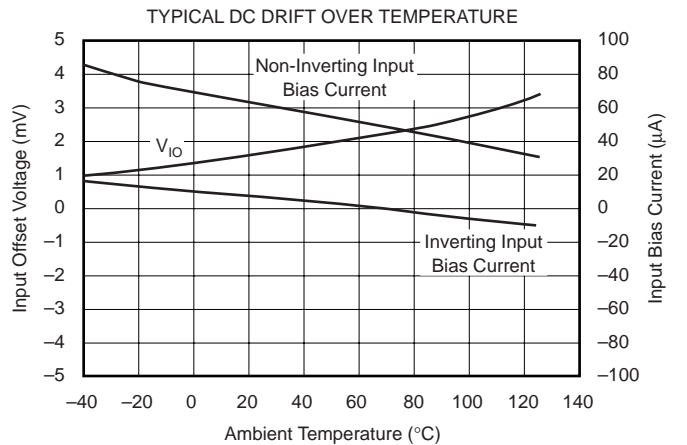
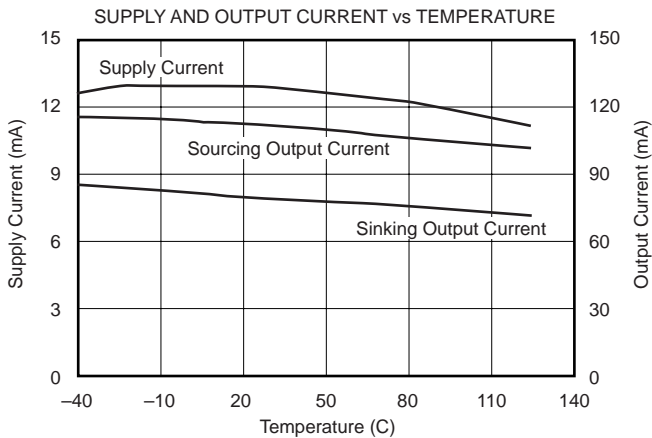
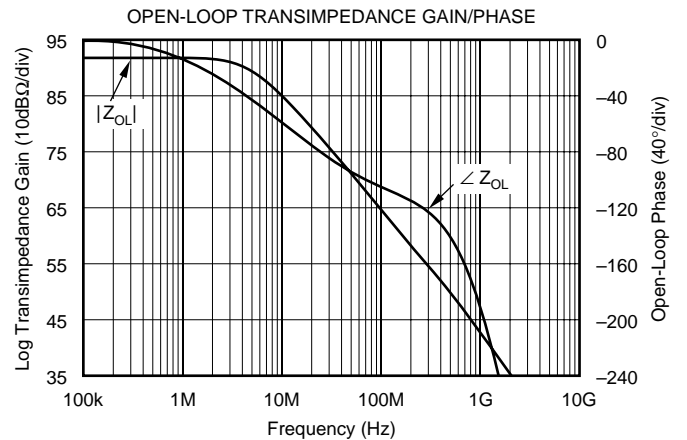
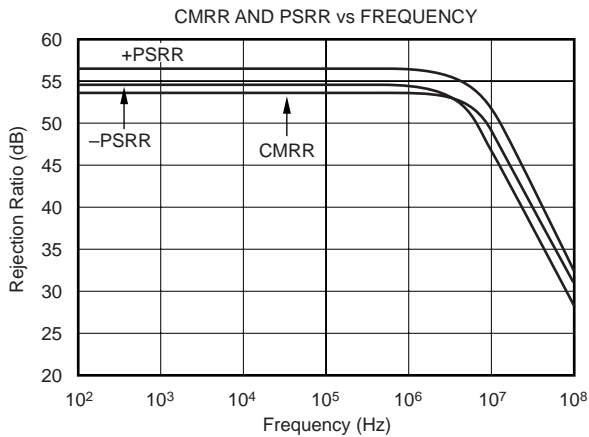
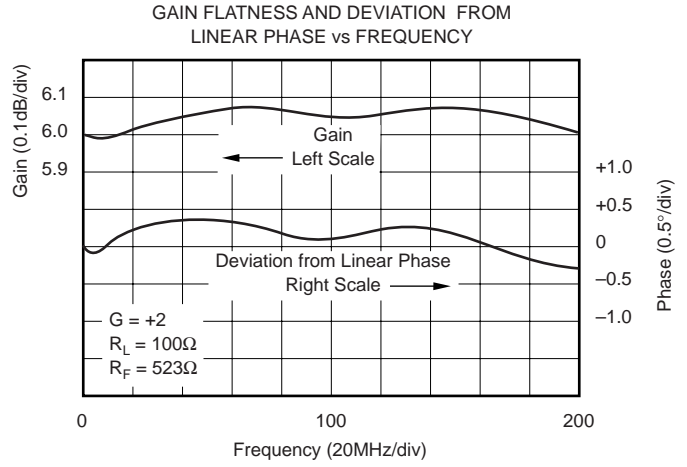
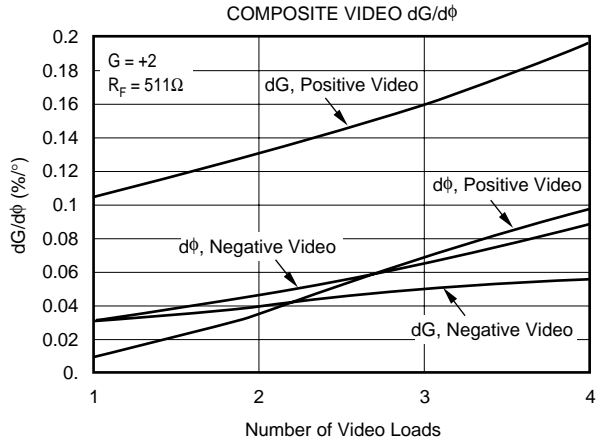

# TYPICAL PERFORMANCE CURVES: $V_S = \pm 5V$ (CONT)

$G = +8$ ,  $R_F = 402\Omega$ , and  $R_L = 100\Omega$ , unless otherwise noted.

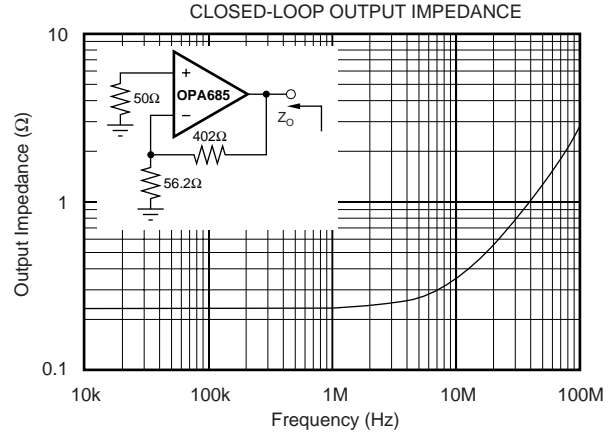
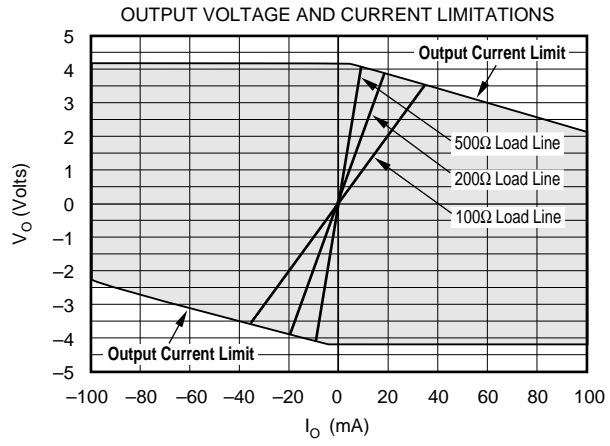

# TYPICAL PERFORMANCE CURVES: $V_S = +5V$

$G = +8$ ,  $R_F = 348\Omega$ , and  $R_L = 100\Omega$ , unless otherwise noted.

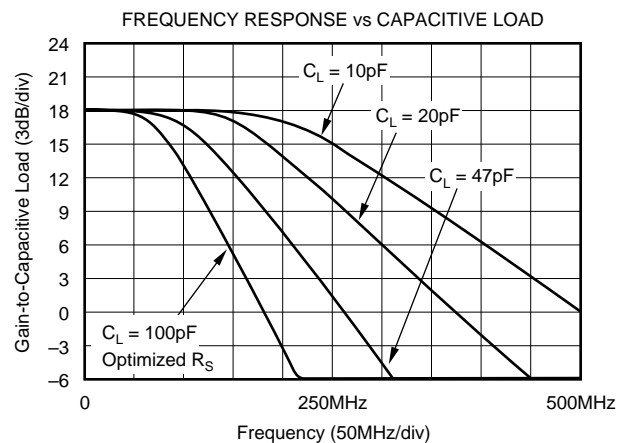
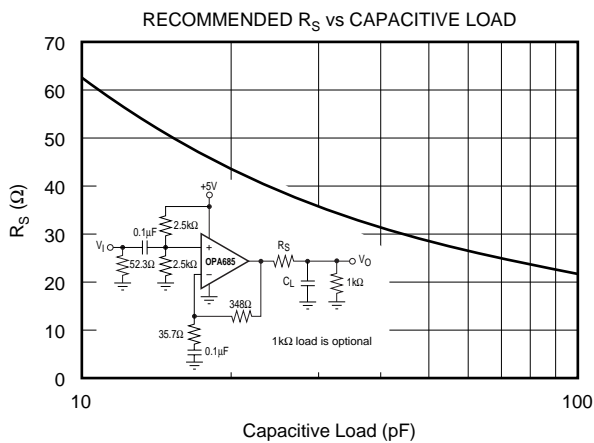
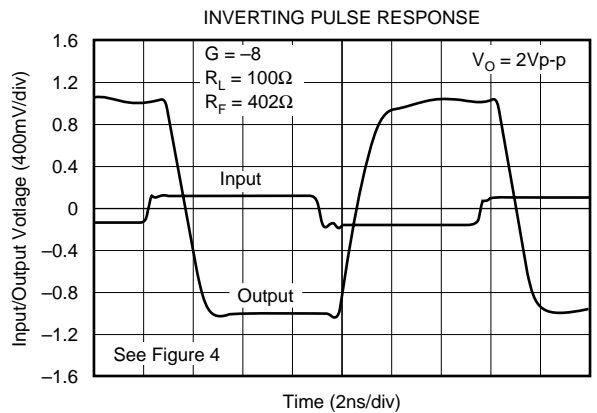
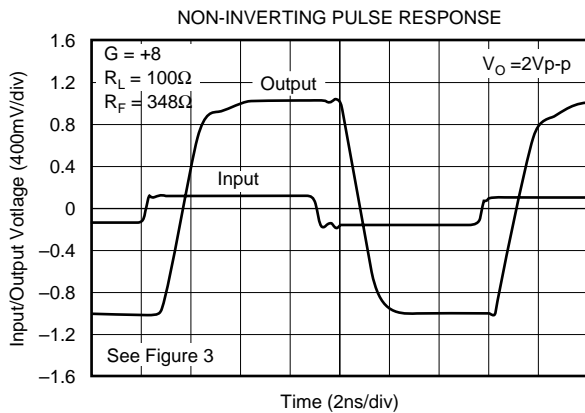
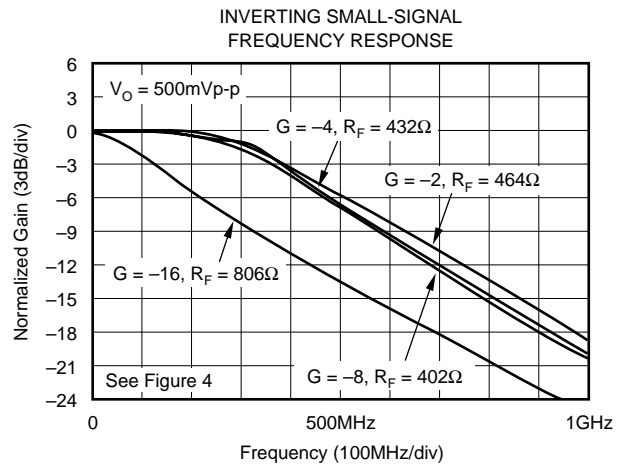
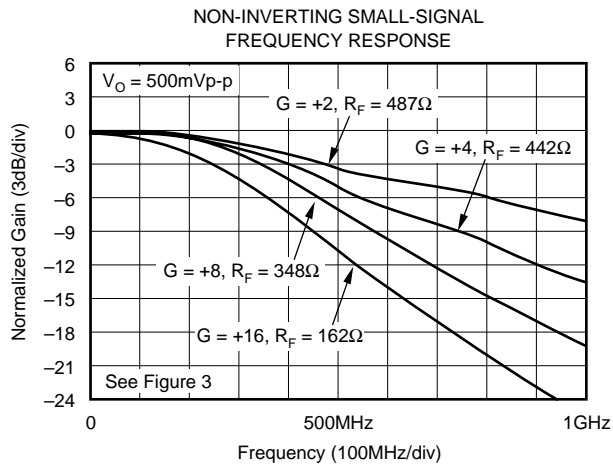

# TYPICAL PERFORMANCE CURVES: $V_S = +5V$ (CONT)

$G = +8$ ,  $R_F = 348\Omega$ , and  $R_L = 100\Omega$ , unless otherwise noted.

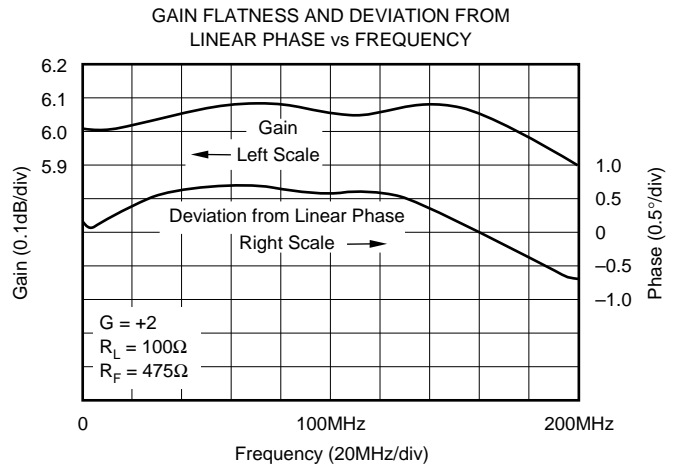
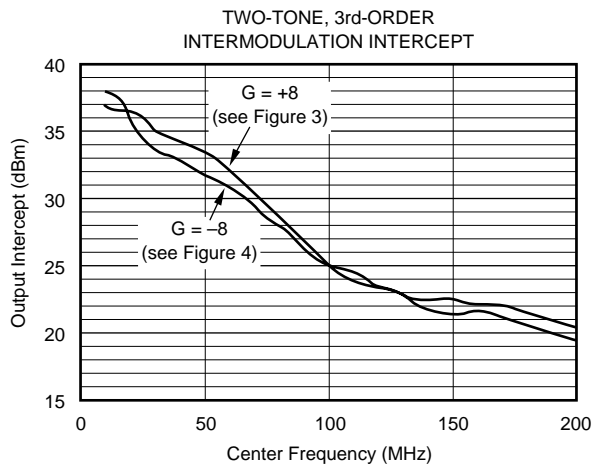
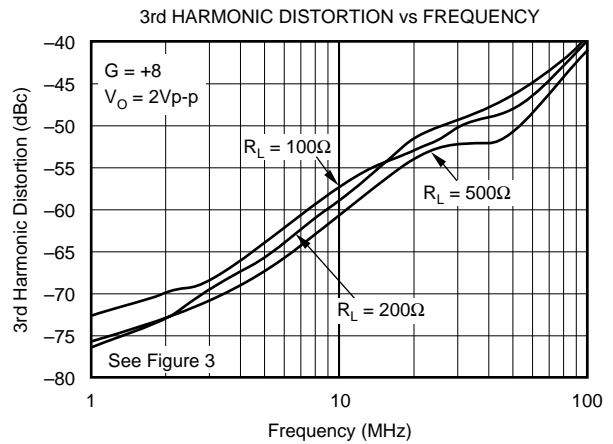
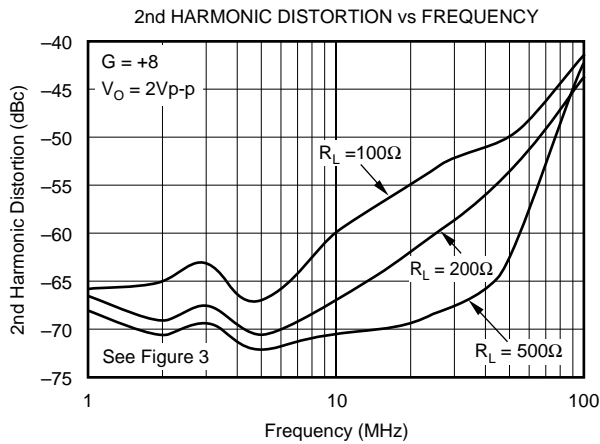
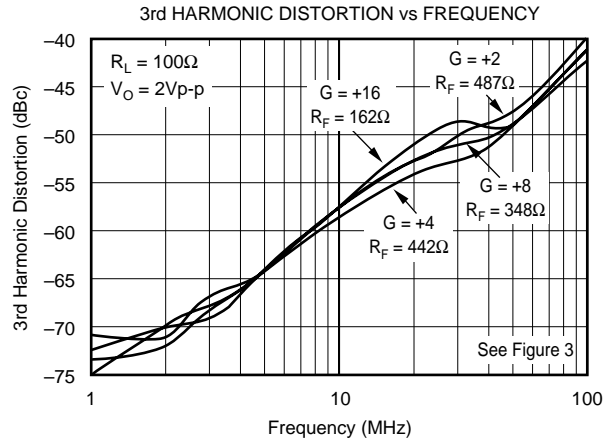
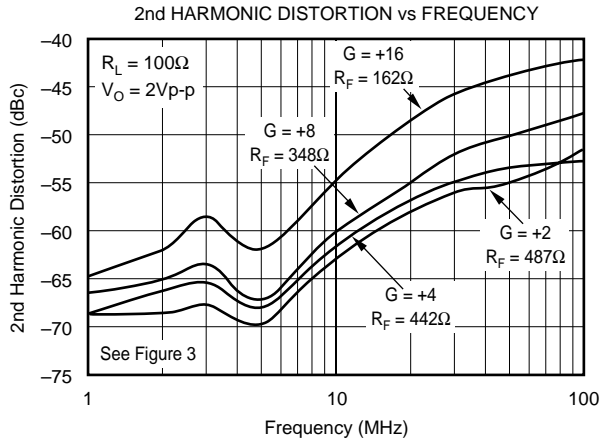

# APPLICATIONS INFORMATION

## WIDEBAND CURRENT-FEEDBACK OPERATION

The OPA685 gives a new level of performance in wideband current-feedback op amps. Nearly constant AC performance over a wide gain range, along with 4200V/ $\mu$ s slew rate, offers a lower power, lower cost solution for high intercept IF amplifier requirements. While optimized at a gain of 8V/V (12dB to a matched 50 $\Omega$  load) to give 400MHz bandwidth, application from gains of 1 to 100 can be supported. As a video line driver (gain of +2), the bandwidth extends to 900MHz, with a slew rate to support the highest pixel rates. At gains above 20, the signal bandwidth starts to decrease but still exceeds 50MHz up to a gain of 80V/V (32dB to a matched 50 $\Omega$  load). Single +5V supply operation is also supported with similar bandwidths, but reduced output power capability. For lower speed (< 250MHz) requirements at higher output power, consider the OPA681.

Figure 1 shows the DC-coupled, gain of +8V/V, dual power supply circuit used as the basis of the  $\pm$ 5V Specifications and Typical Performance Curves. For test purposes, the input impedance is set to 50 $\Omega$  with a resistor to ground and the output impedance is set to 50 $\Omega$  with a series output resistor. Voltage swings reported in the specifications are taken directly at the input and output pins, while load power (dBm) is defined at a matched 50 $\Omega$  load. For the circuit of Figure 1, the total effective load will be 100 $\Omega$  || 458 $\Omega$  = 82 $\Omega$ . The disable control line ( $\overline{\text{DIS}}$ ) is typically left open to guarantee normal amplifier operation. One optional component is included in Figure 1. In addition to the usual power

supply de-coupling capacitors to ground, a 0.1 $\mu$ F capacitor is included between the two power supply pins. In practical PC board layouts, this optional capacitor will typically improve the 2nd harmonic distortion performance by 3dB to 6dB for bipolar supply operation.

Figure 2 shows the DC-coupled, gain of -8V/V, dual power supply circuit used as the basis of the Inverting Typical Performance Curves. Inverting operation offers several performance benefits. Since there is no common-mode signal across the input stage, the slew rate for inverting operation is higher and the distortion performance is slightly improved. An additional input resistor,  $R_T$ , is included in Figure 2 to set the input impedance equal to 50 $\Omega$ . The parallel combination of  $R_T$  and  $R_G$  set the input impedance. Both the non-inverting and inverting applications of Figures 1 and 2 will benefit from optimizing the feedback resistor value for bandwidth (see the discussion in Setting Resistor Values to Optimize Bandwidth). As the gain increases for the inverting configuration, a point will be reached where  $R_G$  will equal 50 $\Omega$ ;  $R_T$  is removed with the input match set by  $R_G$  only. With  $R_G$  fixed to achieve an input match of 50 $\Omega$ , to increase gain,  $R_F$  is simply increased to get higher gain. This will, however, quickly reduce the achievable bandwidth as shown by the inverting gain of -16 frequency response in the Typical Performance Curves. For gains > 12V/V (15.5dB at the matched load), non-inverting operation will give a higher bandwidth.

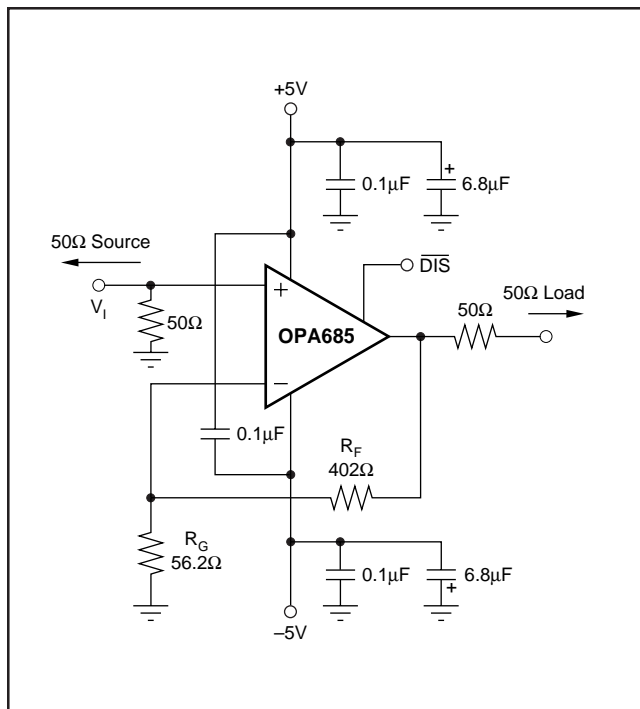

FIGURE 1. DC-Coupled,  $G = +8\text{V/V}$ , Bipolar Supply Specifications and Test Circuit.

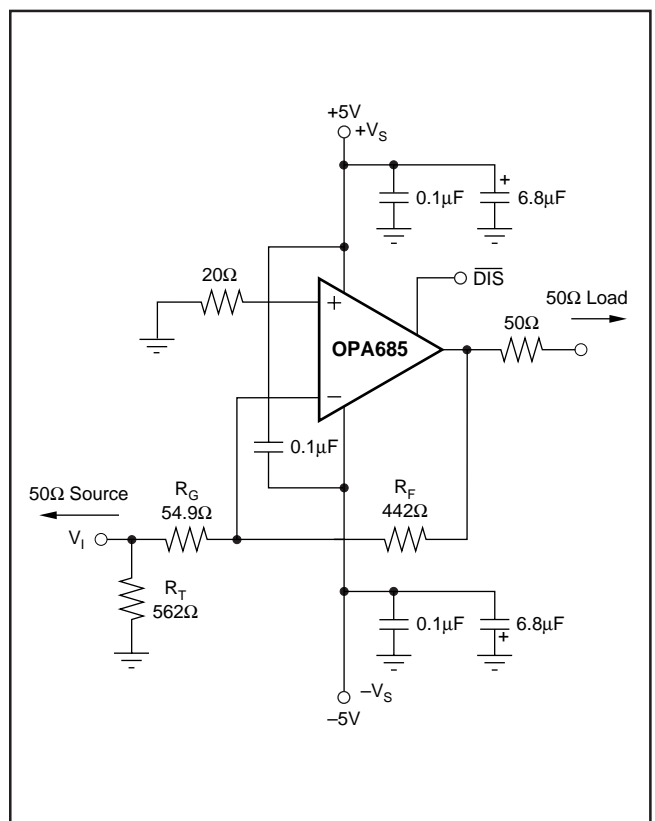

FIGURE 2. DC-Coupled,  $G = -8\text{V/V}$ , Bipolar Supply Specifications and Test Circuit.

Figure 3 shows the AC-coupled, single +5V supply, gain of +8V/V circuit configuration used as the basis for the +5V only Specifications and Typical Performance Curves. The key requirement of broadband single-supply operation is maintaining input and output signal swings within the specified useable voltage ranges. The circuit in Figure 3 establishes an input midpoint bias using a simple resistive divider from the +5V supply (two 806Ω resistors) to the non-inverting input. The input signal is then AC-coupled into this midpoint voltage bias. The input voltage can swing to within 1.7V of either supply pin, giving a 1.4Vp-p input signal range centered around the +5V supply midpoint. The input impedance matching resistor (57.6Ω) used in Figure 3 is adjusted to give a 50Ω input match when the parallel combination of the biasing divider network is included. The gain resistor ( $R_G$ ) is AC-coupled, giving the circuit a DC gain of +1, which puts the input DC bias voltage (2.5V) at the output as well. The feedback resistor value has been adjusted from the bipolar supply condition to re-optimize for a flat frequency response in +5V only, gain of +8, operation (see Setting Resistor Values to Optimize Bandwidth section of this data sheet). On a single +5V supply, the output voltage can swing to within 1.4V of either supply pin while delivering more than 70mA output current, giving a 2.2V

output swing into 100Ω (5dBm maximum at the matched load). The circuit of Figure 3 shows a blocking capacitor driving into a 50Ω output resistor, then into a 50Ω load. Alternatively, the blocking capacitor could be removed if the load is tied to a supply midpoint, or to ground if the DC current required by the load is acceptable.

Figure 4 shows the AC-coupled, single +5V supply, gain of -8V/V circuit configuration used as the basis for the +5V only Typical Performance Curves. In this case, the midpoint DC bias on the non-inverting input is also decoupled with an additional 0.1μF decoupling capacitor. This reduces the source impedance at higher frequencies for the non-inverting input bias current noise. This 2.5V bias on the non-inverting input pin also appears on the inverting input pin and, since  $R_G$  is DC-blocked by the input capacitor, will also appear at the output pin. One advantage to inverting operation is that since there is no signal swing across the input stage, higher slew rates and operation at even lower supply voltages is possible. To retain a 1Vp-p output capability, operation down to a +3V supply is allowed. At a +3V supply, the input common-mode range is 0V, but for the inverting configuration of a current feedback amplifier, wideband operation is retained even with the input stage saturated. The circuit in Figure 4 can be operated down to a 3V supply with > 200MHz, 1Vp-p output.

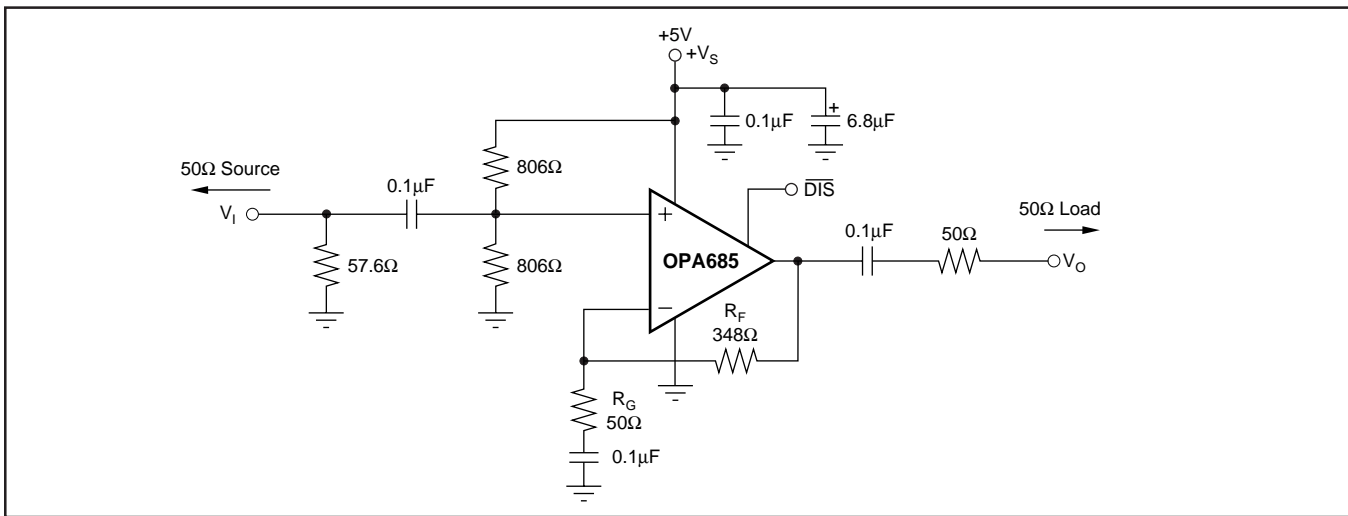

FIGURE 3. AC-Coupled,  $G = +8V/V$ , Single-Supply Specifications and Test Circuit.

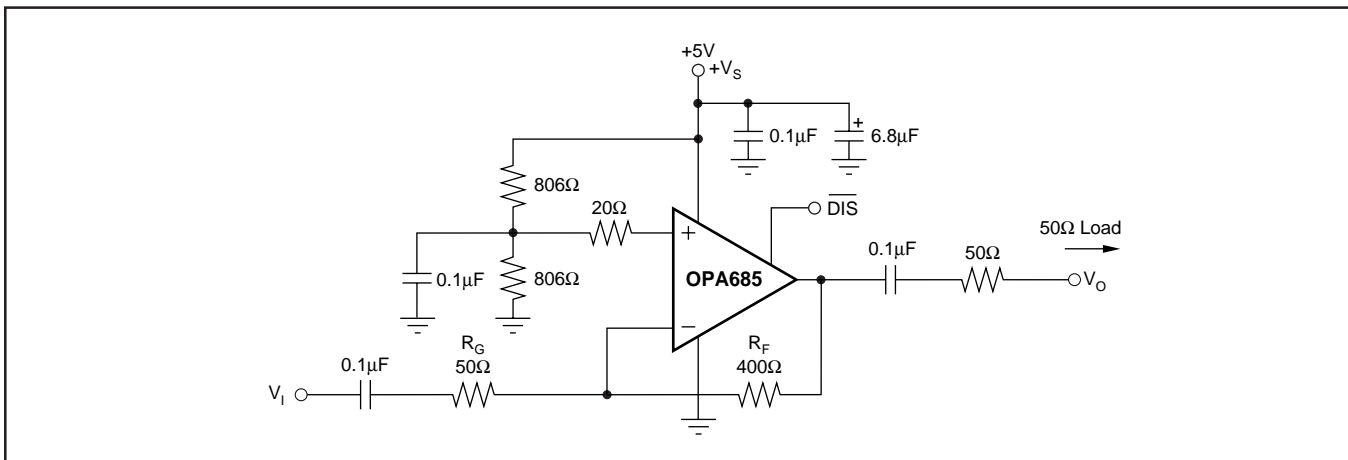

FIGURE 4. AC-Coupled,  $G = -8V/V$ , Single-Supply Specifications and Test Circuit.

# RF SPECIFICATIONS AND APPLICATIONS

The ultra-high full power bandwidth and 3rd-order intercept of the OPA685 may be used to good advantage in IF amplifier applications. Additional benefits in using a wideband op amp such as the OPA685 include extremely good (and independent) I/O impedance matching as well as very high reverse isolation. A designer accustomed to using fixed-gain RF amplifiers will get almost perfect gain accuracy, much higher I/O return loss, and 3rd-order intercept points exceeding 40dBm (up to 50MHz) using only 12mA supply current for the OPA685. Using the considerable design freedom given by adjusting the external resistors, the OPA685 can replace a wide range of fixed-gain RF amplifiers with a single part. To understand in RF amplifier terms how to take advantage of this, first consider the four ‘S’ parameters (this will be done using the example circuits of Figures 1 and 2 on  $\pm 5V$  supplies. However, similar results can be obtained on a single +5V supply).

## INPUT RETURN LOSS ( $S_{11}$ )

This is a measure of how closely (over frequency) the input impedance matches the source impedance. This is relatively independent of gain setting for both the non-inverting and inverting configurations. The Typical Performance Curves show the magnitude of  $S_{11}$  through 1GHz for the circuits of Figures 1 and 2 (non-inverting gain of +8 and inverting gain of -8 operation, respectively). Non-inverting operation offers better matching to higher frequencies with the only deviation due to the parasitic input capacitance of the non-inverting input. The non-inverting input match is set simply by the resistor to ground on the non-inverting input since the amplifier itself shows a very high input impedance. Inverting operation is also very good, but  $S_{11}$  rises more quickly due to loop gain roll-off effects appearing at the inverting node. The inverting mode input match is set by the parallel combination of  $R_G$  and  $R_T$  in Figure 2 since the inverting amplifier node may be considered a virtual ground. A good fixed-gain RF amplifier would have an input Voltage Standing Wave Ratio (VSWR) < 1.2:1. This corresponds to an  $S_{11}$  of -21dB. The OPA685 exceeds this performance through 100MHz for the inverting mode of operation and through 250MHz for the non-inverting.

## OUTPUT RETURN LOSS ( $S_{22}$ )

This is a measure of how closely (over frequency) the output impedance matches the load impedance. This is relatively independent of gain for both non-inverting and inverting operation. To first-order, the output matching impedance is simply set by adding a series resistor to the low impedance output of the op amp. Since the op amp itself shows a very low output impedance which increases with frequency, an improvement in the output match can be obtained by adding a small equalizing capacitor across this output resistor. The Typical Performance Curves show the measured  $S_{22}$  with and without this 3.3pF capacitor across the 50 $\Omega$  output resistor. Again, a very good match for a fixed-gain RF

amplifier would be a VSWR of 1.2:1. Looking at the Typical Performance Curves for  $S_{22}$  and where it rises above -21dB, the OPA685 exceeds this level of performance through 100MHz without the equalizing capacitor and through 250MHz with it.

## FORWARD GAIN ( $S_{21}$ )

In all high-speed amplifier data sheets, this is referred to as the small-signal gain which is plotted over frequency. The difference between non-inverting and inverting operation is that the phase of  $S_{21}$  starts out at 0° for the non-inverting and -180° for the inverting. This initial phase shift for inverting mode is inconsequential to most IF strip applications. The phase of OPA685 is shown in the Typical Performance Curves as a part of the gain flatness curve. It is very linear with frequency and may be accurately modeled as a constant time delay through the amplifier.

The Typical Performance Curves for the OPA685 show  $S_{21}$  over a range of signal gains where the external resistors have been adjusted to re-optimize flatness at each gain setting. Since this is a current-feedback op amp, the signal bandwidth can be held relatively constant as the desired gain setting is changed. The “Non-Inverting Small-Signal Frequency Response” curve shows some change in bandwidth versus gain (due to parasitic capacitive effects on the inverting node) with very little variation for inverting operation.

Signal gains are most often referred to as V/V in op amp data sheets. This is the voltage gain from input to output and is set by external resistor ratios. Since the output impedance is set by a physical series resistor, the voltage gain to the matched load is cut in half by this resistor divider (Figures 1 and 2). The log gain to the matched load for the non-inverting circuit of Figure 1 is:

$$G^+ = 20 \log \frac{1}{2} \left( 1 + \frac{R_F}{R_G} \right) \text{dB} \quad (1)$$

The log gain to the matched load for the inverting circuit of Figure 2 is:

$$G^- = 20 \log \frac{1}{2} \left( \frac{R_F}{R_G} \right) \text{dB} \quad (2)$$

The specific resistor values used in Figures 1 and 2 give both a maximally flat bandwidth and a log gain to the matched load of 12dB. The design tables at the end of this section summarize the required resistor values over a range of desired gains for the circuits of Figures 1 and 2.

As the desired signal gain increases, the achievable bandwidth will decrease. In the non-inverting case, it decreases relatively quickly, as shown in the Typical Performance Curves. The inverting configuration holds almost constant bandwidth (with correctly selected external resistor values) until  $R_G$  reduces to 50 $\Omega$  and remains at that value to satisfy the input impedance matching requirement. Further increases in gain are achieved by increasing  $R_F$ , shown in Figure 2. The bandwidth then decreases rapidly as shown by the gain of -16V/V plot in the Typical Performance Curves.

## REVERSE ISOLATION (S<sub>12</sub>)

This is a measure of how much power injected into the output matching resistor appears at the input. This is rarely specified for an op amp because it is so good. Op amps are very nearly uni-directional signal devices. The Typical Performance Curves show this performance in the “Isolation Characteristics vs Frequency” curve. Below 300MHz, the non-inverting configuration of Figure 1 gives much better isolation than the inverting of Figure 2. However, both are well below 40dB isolation through 350MHz. Shown also on this plot is the forward isolation for S<sub>21</sub> when the OPA685 is disabled. This also stays under -40dB up to 700MHz. This specification is not shown for the inverting mode since the signal will couple directly through the external resistors when the amplifier is disabled for the circuit of Figure 2. If off-isolation is a concern, the non-inverting configuration would be preferred.

## DYNAMIC RANGE LIMITS

The next consideration for RF amplifier applications are what limits to dynamic range may be defined. Typical fixed-gain RF amplifiers include:

-1dB compression (a measure of maximum output power)

2-tone, 3rd order, output intermodulation intercept (a measure of achievable Spurious Free Dynamic Range, SFDR)

Noise Figure (NF, a measure of degradation in signal-to-noise ratio in passing through the amplifier)

### -1dB Compression

The -1dB compression power is defined as the output power at which the actual power is 1dB less than the input power plus the log gain. In classic RF amplifiers, this is typically 10dB less than the 3rd-order intercept. This does not hold for op amps since their intercepts are considerably improved by loop gain and exceed the -1dB compression by much more than 10dB. A simple estimate for -1dB compression for the OPA685 is the maximum non-slew limited output voltage swing available at the matched load converted into power with 1dB added to satisfy the definition. For the OPA685 on ±5V supplies, the output will deliver ±3.6V at the output pin, or ±1.80V at the matched load. The conversion from V<sub>p-p</sub> to power (for a sine wave) is:

$$P_O \text{ (dBm)} = 10 \log \left[ \frac{\left( \frac{V_{p-p}}{2\sqrt{2}} \right)^2}{0.001 (50\Omega)} \right] \quad (3)$$

Converting this 3.6V<sub>p-p</sub> swing at the load to dBm gives 15.1dBm. Adding 1dB to this (to satisfy the definition) gives a -1dB compression of 16.1dBm for the OPA685 operating on ±5V supplies. This will be a good estimate for frequencies that require less than the full slew rate of the OPA685. The maximum frequency of operation given an available slew rate and desired peak output swing (at the output pin) for a sine wave is:

$$f_{\text{MAX}} = \frac{\text{Slew Rate}}{2\pi V_p} \quad (4)$$

Using the 4200V/μs slew rate available in the inverting mode of operation and the 3.6V peak output swing at the output pin, gives a maximum frequency of 186MHz. This is the maximum frequency where the -1dB compression would be 16.1dBm at the matched load. Higher useable bandwidths are possible at lower output power, as shown in the large-signal bandwidth curves. As those curves show, 7V<sub>p-p</sub> outputs are possible with almost perfect frequency response flatness through 100MHz for both non-inverting or inverting operation.

## Two-Tone, 3rd-Order Output Intermodulation Intercept (OP3)

In narrowband IF strips, each amplifier typically feeds into a bandpass filter that attenuates most harmonic distortion terms. The most troublesome remaining distortion is the 3rd-order, 2-tone intermodulations that can fall very close in frequency to the desired signals and cannot be filtered out. If two test frequencies are defined at f<sub>O</sub> + Δf and f<sub>O</sub> - Δf, the 3rd-order intermodulation distortion products will fall at f<sub>O</sub> + 3Δf and f<sub>O</sub> - 3Δf. If the two test power (P<sub>T</sub>) levels are equal, the OPA685 will produce 3rd-order products (P<sub>S</sub>) that are at these frequencies and at a power level below the test power levels given by:

$$P_T - P_S = 2 \text{ (OP3 - } P_T) \quad (5)$$

The “Two-Tone, 3rd-Order Intermodulation Intercept” curve shown in the Typical Performance Curves shows a very high intercept at low frequencies, that decreases with increasing frequency. This intercept is defined at the matched load to allow direct comparison with fixed-gain RF amplifiers. To produce a 2V<sub>p-p</sub> total, 2-tone envelope at the matched load, each power level must be 4dBm at the matched load (1V<sub>p-p</sub>). Using Equation 5 and the performance curve for inverting operation, at 50MHz (41.5dBm intercept), the 3rd-order spurious will be 2 • (41.5-4) = 75dB below these 4dBm test tones. This is exceptionally low distortion for an amplifier that only uses 12mA supply current. Considerable improvement from this level of performance is also possible if the output drives directly into the lighter load of an ADC input (see Differential ADC Driver section of this data sheet).

This very high intercept versus quiescent power is achieved by the high loop gain of the OPA685. This loop gain does, however, decrease with frequency giving the decreasing output intercept performance shown in the Typical Performance Curves. Application as an IF amplifier through 200MHz is possible with output intercepts exceeding 21dBm at 200MHz. Intercept performance will vary slightly with gain setting decreasing at higher gains (than the 8V/V or 12dB gain used in the Typical Performance Curves) and increasing at lower gains.

## NOISE FIGURE

All fixed-gain RF amplifiers show good Noise Figure (typically < 5dB). For broadband RF amplifiers, this is achieved by a low noise input transistor and an input match set by feedback. This feedback greatly reduces the Noise Figure



for fixed-gain RF amplifiers, but also makes the input match dependent on load and the output match dependent on the source impedance at the input.

The Noise Figure for an op amp is always higher than for fixed-gain RF amplifiers due to their more complex internal circuits (giving higher input noise voltage and current terms) and the fact that, for simple circuits, the input match is set resistively. What is gained is an almost perfect I/O impedance match, much better load isolation, and very high 3rd order intercepts versus quiescent power. This higher Noise Figure can be acceptable if the OPA685 has enough gain preceding it in the IF chain.

Op amp Noise Figure equations include at least 6 terms (see the Noise Performance section of this data sheet) due to the external resistors. As a point of reference, the circuit of Figure 1 has an input Noise Figure of 14dB, while the inverting configuration of Figure 2 has an input Noise Figure of 11dB. At higher gains, it is typical for the inverting Noise Figure to be slightly better than for an equivalent gain non-inverting configuration. One easy way to improve the Noise Figure for the non-inverting configuration of the OPA685 is to include a 1:2 step-up transformer at the input (Figure 5).

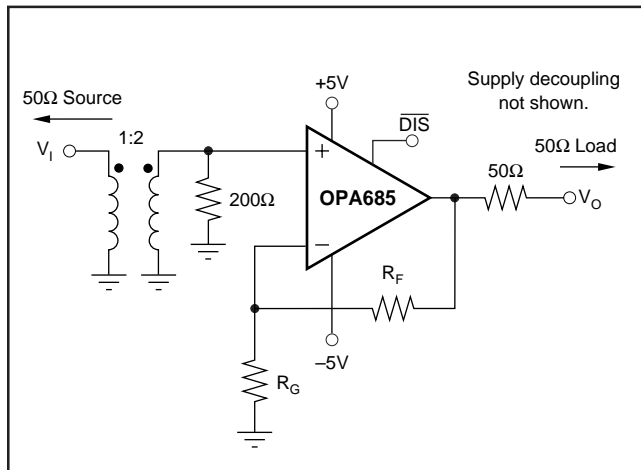

FIGURE 5. IF Amplifier with Improved Noise Figure.

The transformer provides a noiseless voltage gain at the expense of higher source impedance for the OPA685's non-inverting input current noise. The input impedance is still set to 50Ω by the 200Ω resistor on the transformer secondary. Using a 1:2 step-up will cut the required amplifier gain in half for any particular desired overall gain.

The following tables summarize the recommended resistor values and resulting Noise Figures over desired gain setting for three circuit options for the OPA685 operated as a precision IF amplifier. In each case,  $R_F$  and  $R_G$  are adjusted for both best bandwidth and to get the required gain.

Table I. Non-inverting circuit of Figure 1

Table II. Non-inverting circuit of Figure 5 with a 1:2 input step up transformer

Table III. Inverting circuit of Figure 2

In all cases, exact computed values for resistors are shown. Choose standard resistor values which are closest to those in the tables for implementation.

GAIN TO LOAD (dB)	$R_F$ ( $\Omega$ )	$R_G$ ( $\Omega$ )	NOISE FIGURE
6	478	159	17.20
7	468	134	16.55
8	458	113	15.95
9	446	96	15.40
10	433	81	14.91
11	419	68	14.47
12	402	57	14.09
13	384	48	13.76
14	363	40	13.23
15	340	33	13.23
16	314	27	13.03
17	284	21	12.86
18	252	16	12.72
19	215	12	12.60
20	174	9	12.51

TABLE I. Non-Inverting Wideband Op Amp (Figure 1).

GAIN TO LOAD (dB)	$R_F$ ( $\Omega$ )	$R_G$ ( $\Omega$ )	NOISE FIGURE
6	516	518	16.34
7	511	412	15.54
8	506	334	14.78
9	500	275	14.07
10	493	228	13.40
11	486	190	12.78
12	478	160	12.21
13	469	135	11.70
14	458	114	11.25
15	447	96	10.85
16	434	81	10.15
17	419	69	10.21
18	403	58	9.96
19	384	48	9.74
20	364	40	9.57

TABLE II. Non-Inverting with a 1:2 Input Step-Up Transformer (Figure 5).

GAIN TO LOAD (dB)	OPTIMUM $R_F$ ( $\Omega$ )	$R_G$ ( $\Omega$ )	INPUT MATCH $R_T$	NOISE FIGURE
6	463.27	116	87	16.94
7	454.61	101	98	16.06
8	444.91	88	114	15.16
9	434.07	77	142	14.23
10	421.95	66	199	13.24
11	408.42	57	380	12.16
12	398.11	50	Infinite	11.03
13	446.68	50	Infinite	10.92
14	501.19	50	Infinite	10.83
15	562.34	50	Infinite	10.75
16	630.96	50	Infinite	10.67
17	707.95	50	Infinite	10.61
18	794.33	50	Infinite	10.55
19	891.25	50	Infinite	10.49
20	1000.00	50	Infinite	10.45

TABLE III. Inverting Wideband RF Amplifier (Figure 2).

## SAW FILTER BUFFER

One common requirement in an IF strip is to buffer the output of a mixer with enough gain to recover the insertion loss of a narrowband SAW filter. The front page of this data sheet shows a recommended circuit using the OPA685. Operating in the inverting mode at a voltage gain of  $-8V/V$ , this circuit provides a  $50\Omega$  input match using the gain set resistor, has the feedback optimized for maximum bandwidth (450MHz in this case), and drives through a  $50\Omega$  output resistor into the matching network at the input of the SAW filter. If the SAW filter gives a 12dB insertion loss, a net gain of 0dB to the  $50\Omega$  load at the output of the SAW (which could be the input impedance of the next IF amplifier or mixer) will be delivered in the passband of the SAW filter. Using the OPA685 in this application will isolate the first mixer from the impedance of the SAW filter and provide very low 3rd-order, 2-tone spurious levels at the carrier frequency. Inverting operation as shown on the front page will give the broadest bandwidth up to a gain of  $12V/V$  (15.6dB). Non-inverting operation will give higher bandwidth at gain settings higher than this, but will give a slight reduction in intercept and Noise Figure performance.

## LO BUFFER AMPLIFIER

The OPA685 may also be used to buffer the Local Oscillator (LO) from the mixer(s). Operating at a voltage gain of +2, the OPA685 will provide almost perfect load isolation for the LO with a net gain of 0dB to the mixer. Applications through 1GHz LOs may be considered, but best operation would be for LOs < 500MHz at a gain of +2. Gain could also be easily provided by the OPA685 to drive higher power levels into the mixer. One unique option in using the OPA685 as an LO buffer is shown in Figure 6. Since the OPA685 can

drive multiple output loads, two identical LO signals may be delivered to the mixers in a diversity receiver simply by tapping the output off through two series  $50\Omega$  output resistors. This circuit is set up for a voltage gain of  $+2V/V$  to the output pin for a gain of  $+1V/V$  (0dB) to the mixers, but could easily be adjusted to deliver higher gains as well.

## WIDEBAND CABLE DRIVING APPLICATIONS

The high slew rate and bandwidth of the OPA685 can be used to meet the most demanding cable driving applications.

### CABLE MODEM RETURN PATH DRIVER

The standard cable modem upstream driver is typically required to drive high power over a 5MHz to 65MHz bandwidth while delivering  $< -50\text{dBc}$  distortion. Highly integrated solutions (including programmable gain stages) often fall short of this target due to high losses from the amplifier output to the line. The higher gain operating capability of the OPA685, along with its very high slew rate, provides a low-cost solution for delivering this signal with the required spurious free dynamic range. Figure 7 shows one example of using the OPA685 as an upstream driver for a cable modem return path. In this case, the input impedance of the driver is set to  $75\Omega$  by the gain resistor ( $R_G$ ). The required input level from the adjustable gain stage is significantly reduced by the 15.5dB gain provided by the OPA685. In this example, the physical  $75\Omega$  output matching resistor, along with the 3dB loss in the diplexer, will attenuate the output swing by 9dB on the line. In this example, a single +12V supply was used to achieve the lowest harmonic distortion for the 6Vp-p

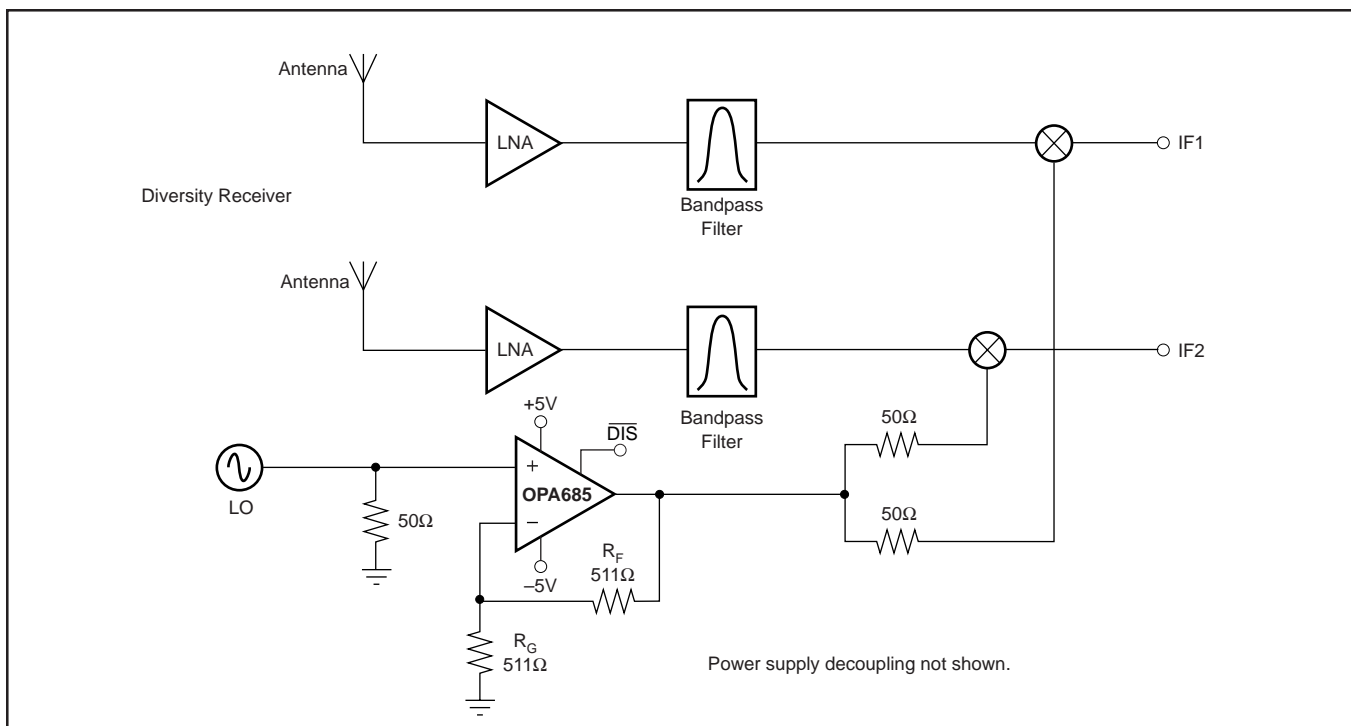

FIGURE 6. Dual Output LO Buffer.

output pin voltage through 65MHz. Measured performance for this example gave 600MHz small-signal bandwidth and  $< -54\text{dBc}$  distortion through 65MHz for a 6Vp-p output pin voltage swing.

An alternative to this circuit, giving even lower distortion, is a differential driver using two OPA685s driving into an output transformer. This can be used either to double the available line power, or to improve distortion by cutting the required output swing in half for each stage. The channel disable required by the MCNS specification should be implemented by using the PGA disable feature. The MCNS disable specification requires that an output impedance match be maintained with the signal channel shut off. The disable feature of the OPA685 is intended principally for power savings and puts the output and inverting input pins into a high impedance mode—this will not maintain the required output impedance matching. Turning off the signal at the input of Figure 7, while keeping the OPA685 active, will maintain the impedance matching while putting very

little noise on the line. The line noise in disable for the circuit of Figure 7 (with the PGA source turned off, but still presenting a  $75\Omega$  source impedance) will be a very low  $4\text{nV}/\sqrt{\text{Hz}}$  ( $-157\text{dBm}/\text{Hz}$ ) due to the low input noise of the OPA685.

### RGB VIDEO LINE DRIVER

The extremely high bandwidth of the OPA685 operating at a gain of +2 will support the fastest RAMDAC outputs for applications such as auxiliary monitor driving. As a general rule, the required full power bandwidth for the amplifier must be at least one-half the pixel rate. With its non-inverting gain of +2, slew rate of  $1900\text{V}/\mu\text{s}$ , and a 1.4Vp-p output pin voltage swing for standard RGB video levels, the OPA685 will give a bandwidth of 400MHz, which will then support up to 800MHz pixel rates. Figure 8 shows an example where three OPA685s provide an auxiliary monitor output for a high resolution RGB RAMDAC.

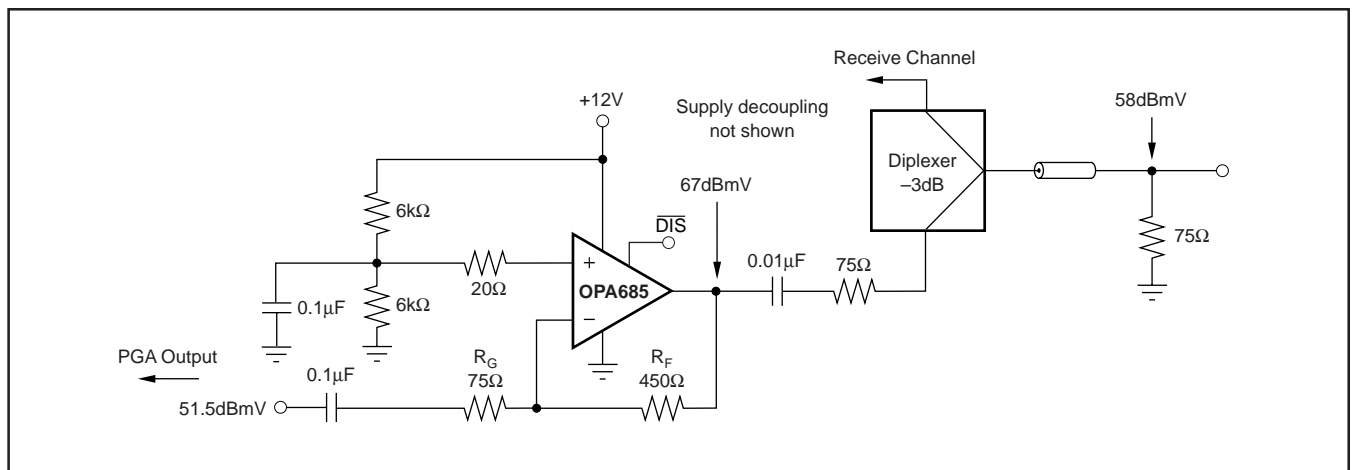

FIGURE 7. Cable Modem Upstream Driver.

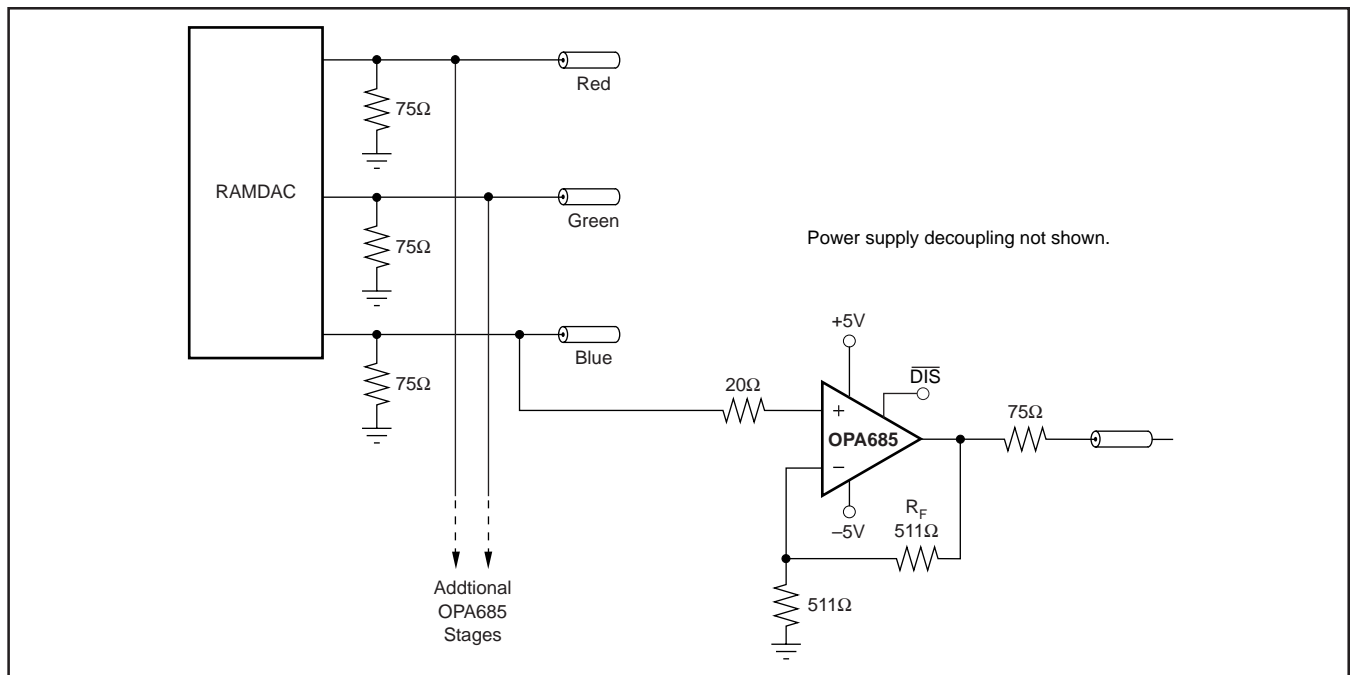

FIGURE 8. Gain of +2 High Resolution RGB Monitor Output

An alternative circuit that will take advantage of the higher inverting slew rate of the OPA685 (4200V/μs), takes the complementary current output from the RAMDAC and converts it to positive video to give a very high full power bandwidth RGB line driver. This will give sharper pixel edges than the circuit of Figure 8. Most high-speed DACs are current-steering designs where there is both an output current signal that is used for the video, and a complementary output that is typically discarded into a matching resistor. The complementary current output can be used as an auxiliary output if it is inverted as shown in Figure 9.

In the circuit of Figure 9, the complementary current output is terminated by an equivalent 75Ω impedance (the parallel combination of  $R_T$  and  $R_G$ ) that also provides a current division to reduce the signal current through the feedback resistor,  $R_F$ . This allows  $R_F$  to be increased to a value which will hold a flat frequency response. Since the complementary current output is essentially an inverted video signal, this circuit sets up a white video level at the output of the OPA685 for zero DAC output current (using the 0.77V DC bias on the non-inverting input), then inverts the complementary output current to produce a signal that ranges from

this 1.4V at zero output current down to 0V at maximum output current level (assuming a 20mA maximum output current). This will give a very wideband (> 400MHz) video signal capability.

### ARBITRARY WAVEFORM DRIVER

The OPA685 may be used as the output stage for moderate output power Arbitrary Waveform Driver applications. Driving out through a series 50Ω matching resistor into a 50Ω matched load will allow up to a 3.6Vp-p swing at the matched load (15dBm) when operating the OPA685 on a ±5V power supply. This level of power is available for gains of either ±8 with a flat response through 100MHz. When interfacing directly from a complementary current output DAC, consider the circuit of Figure 9, modified for the peak output currents of the particular DAC being considered. Where purely AC-coupled output signals are required from a complementary current output DAC, consider a push-pull output stage using the circuit of Figure 10. The resistor values here have been calculated for a 20mA peak output current DAC which produces up to a 5Vp-p swing at the matched load (18dBm). This approach will give higher power at the load with much lower 2nd harmonic distortion.

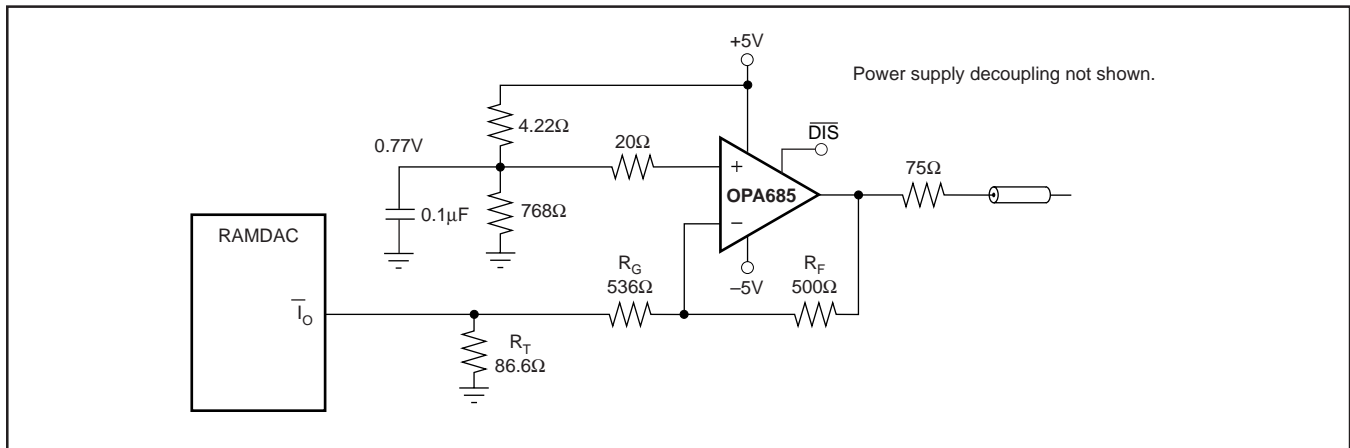

FIGURE 9. High Resolution RGB Driver Using DAC Complementary Output Current.

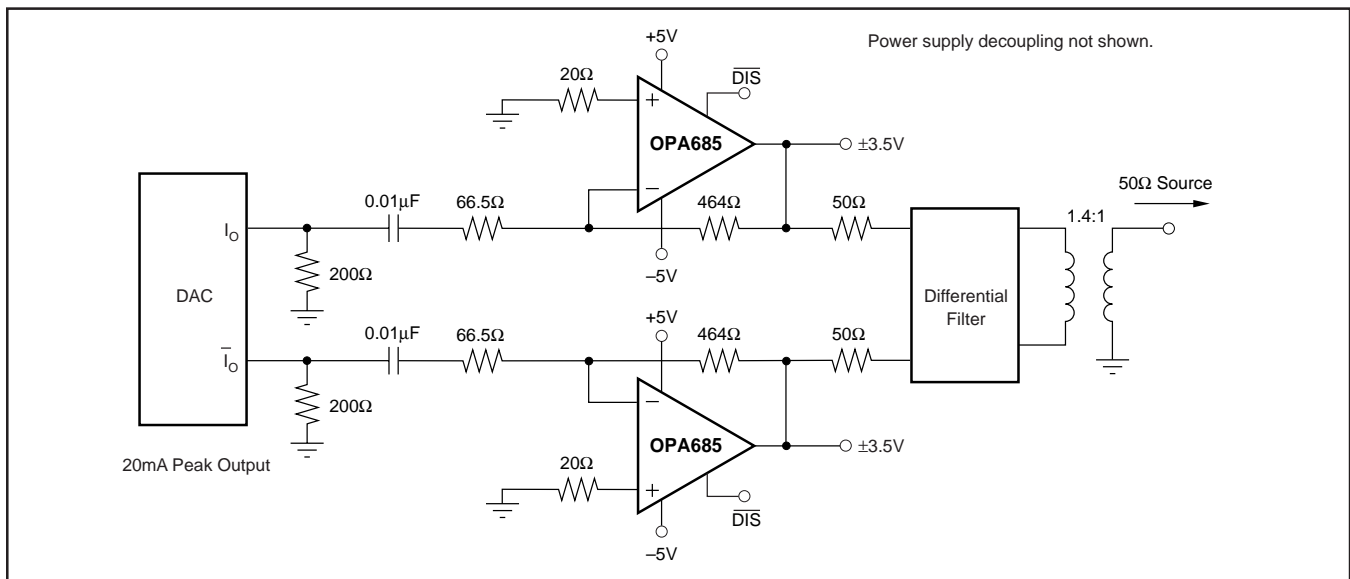

FIGURE 10. High Power, Wideband AC-Coupled ARB Driver.

For a 20mA peak output current DAC, the mid-scale current of 10mA will give a 2V DC output common-mode operating voltage due to the 200Ω resistor to ground at their outputs. The total AC impedance at each output is 50Ω, giving a ±0.5V swing around this 2V common-mode voltage for the DAC. These resistors also act as a current divider sending 75% of the DAC output current through the feedback resistor (464Ω). The blocking capacitor references the OPA685 output voltage to ground, and turns the unipolar DAC output current into a bipolar swing of  $0.75 \cdot 20\text{mA} \cdot 464\Omega = 7\text{Vp-p}$  at each amplifier output. Each output is exactly 180° out-of-phase from the other, producing double 7Vp-p into the matching resistors. To limit the peak output current and improve distortion, the circuit of Figure 10 is set up with a 1.4:1 step-down transformer. This reflects the 50Ω load to be 100Ω at the primary side of the transformer. For the maximum 14Vp-p swing across the outputs of the two amplifiers, the matching resistors will drop this to 7Vp-p at the input of the transformer, then down to 5Vp-p maximum at the 50Ω load at the output of the transformer.

## HIGH-SPEED ADC INPUT DRIVERS

The OPA685 is ideally suited to the demanding input drive requirements of emerging ultra high-speed and high performance ADCs. As a single amplifier stage, 10-bit converters through 100MSPS may be driven, while 8-bit converters may be driven with input frequencies in excess of 100MHz.

Emerging differential input ADCs can also benefit from a purely differential input interface using two OPA685s to get a significant improvement in even-order harmonics along with a somewhat improved 3rd-order harmonic suppression.

### SINGLE-ENDED ADC INPUT INTERFACE

Figure 11 shows an example single +5V supply ADC driver where the AC gain is set to -8V/V. The converter is shown with both an inverting and non-inverting input. The inverting input is used here to make the overall channel non-inverting.

The Typical Performance Curves for the non-inverting gain of +8 show very flat frequency response for +5V only operation when driving into the 20pF load capacitor shown in Figure 11. The inverting configuration of Figure 11 was selected for higher slew rate and lower distortion performance. It will give > 300MHz bandwidth at this gain of -8. Harmonic distortion for a 2Vp-p output signal will be < -50dBc through 50MHz.

### DIFFERENTIAL ADC DRIVER

For applications requiring the lowest harmonic distortion through very high frequencies, a balanced differential circuit using the OPA685 offers the best performance. Figure 12 shows an example of this approach where an input step-up transformer is used to convert to a differential signal and improve the Noise Figure.

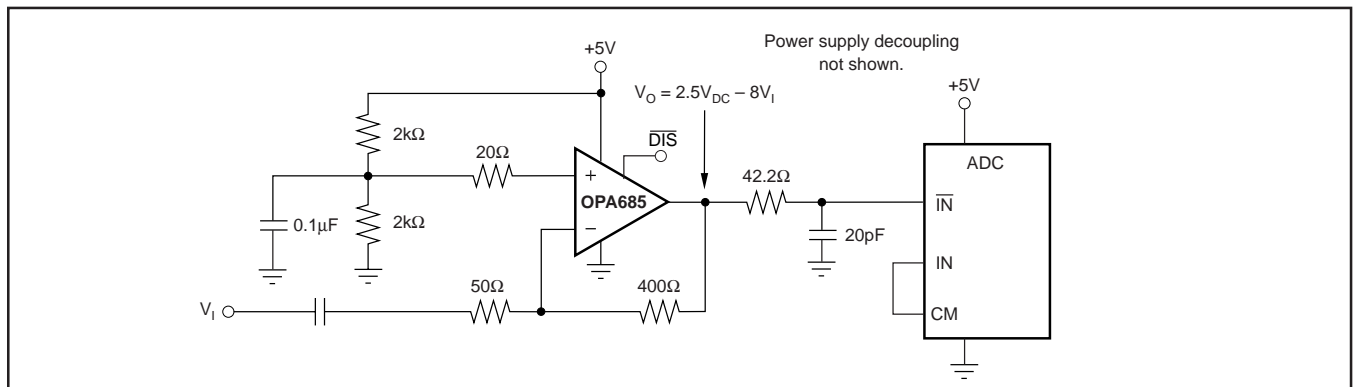

FIGURE 11. Single Supply, Wideband ADC Driver.

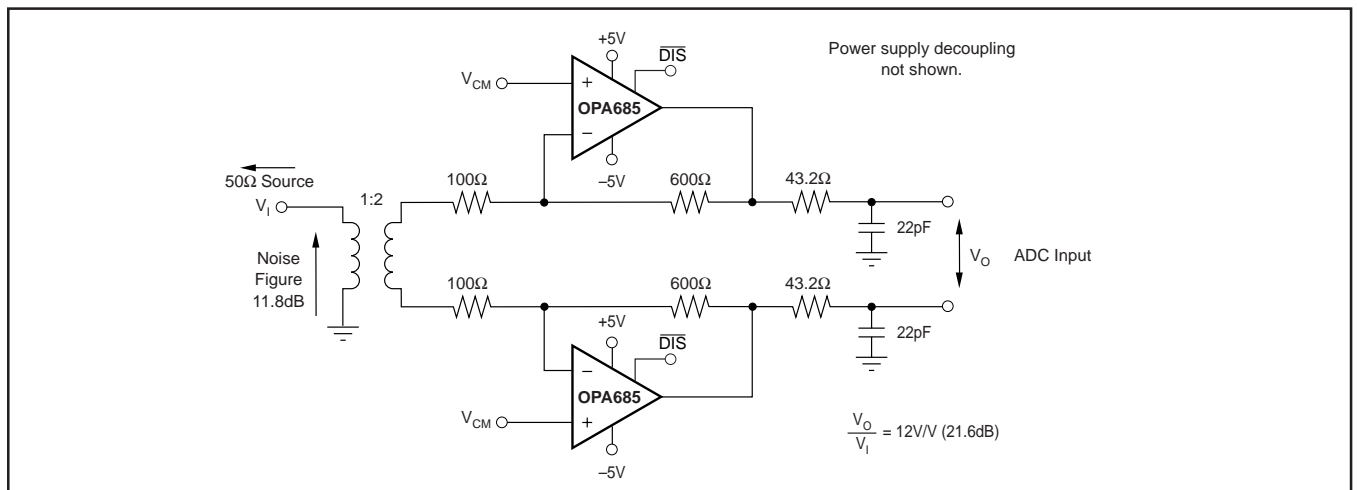

FIGURE 12. Very Wideband Differential ADC Driver

The non-inverting inputs may be used to set the output DC operating voltage independently of the signal path gain. Measured single and 2-tone distortion results for the circuit of Figure 12 are shown in Figure 13, where the outputs are set to a +2.5V common-mode operating voltage to allow direct coupling into a differential input, single +5V supply ADC. This plot shows the SFDR for the worst harmonic over frequency. The balanced differential structure of Figure 12 significantly improves SFDR at low frequencies while holding the performance above 65dBc for a 1Vp-p output through 60MHz.

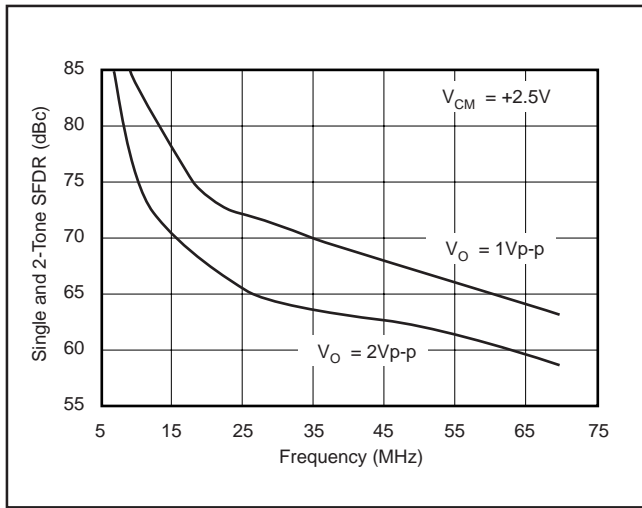

FIGURE 13. Measured SFDR for Differential ADC Driver (Figure 12).

## DESIGN-IN TOOLS

### DEMONSTRATION BOARDS

Two PC boards are available to assist in the initial evaluation of circuit performance using the OPA685 in its two package styles. Both of these are available free as an unpopulated PC board delivered with descriptive documentation. The summary information for these boards is shown below.

PRODUCT	PACKAGE	BOARD PART NUMBER	LITERATURE REQUEST NUMBER
OPA685U	SO-8	DEM-OPA68xU	MKT-351
OPA681N	SOT23-6	DEM-OPA6xxN	MKT-348

Contact the Burr-Brown applications support line to request any of these boards.

## OPERATING SUGGESTIONS

### SETTING RESISTOR VALUES TO OPTIMIZE BANDWIDTH

A current-feedback op amp like the OPA685 can hold an almost constant bandwidth over signal gain settings with the proper adjustment of the external resistor values. This is shown in the Typical Performance Curves. The small-signal bandwidth decreases only slightly with increasing gain. These curves also show that the feedback resistor has been changed for each gain setting. The resistor “values” on the inverting side of the circuit for a current-feedback op amp can be treated as frequency response compensation elements while their “ratios” set the signal gain. Figure 14 shows the analysis circuit for the OPA685 small-signal frequency response.

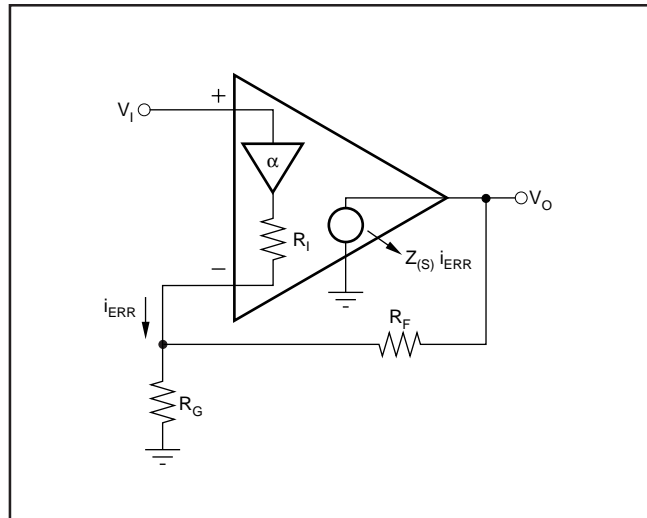

FIGURE 14. Current-Feedback Transfer Function Analysis Circuit.

The key elements of this current feedback op amp model are:

$\alpha \Rightarrow$  Buffer gain from the non-inverting input to the inverting input

$R_I \Rightarrow$  Buffer output impedance

$i_{ERR} \Rightarrow$  Feedback error current signal

$Z(s) \Rightarrow$  Frequency dependent open-loop transimpedance gain from  $i_{ERR}$  to  $V_O$

The buffer gain is typically very close to 1.00 and is normally neglected from signal gain considerations. It will, however, set the CMRR for a single op amp differential amplifier configuration. For the buffer gain  $\alpha < 1.0$ , the  $CMRR = -20 \cdot \log(1 - \alpha)$ .

$R_I$ , the buffer output impedance, is a critical portion of the bandwidth control equation. For the OPA685, it is typically about  $19\Omega$  for  $\pm 5V$  operation and  $23\Omega$  for single  $+5V$  operation.

A current-feedback op amp senses an error current in the inverting node (as opposed to a differential input error voltage for a voltage-feedback op amp) and passes this on to the output through an internal frequency dependent transimpedance gain. The Typical Performance Curves show this open-loop transimpedance response. This is analogous to the open-loop voltage gain curve for a voltage-feedback op amp. Developing the transfer function for the circuit of Figure 14 gives Equation 6:

$$\frac{V_O}{V_I} = \frac{\alpha \left(1 + \frac{R_F}{R_G}\right)}{R_F + R_I \left(1 + \frac{R_F}{R_G}\right) + \frac{\alpha NG}{Z(s)}} = \frac{\alpha NG}{1 + \frac{R_F + R_I NG}{Z(s)}} \quad (6)$$

$$\left[ NG = \left(1 + \frac{R_F}{R_G}\right) \right]$$

This is written in a loop gain analysis format where the errors arising from a non-infinite open-loop gain are shown in the denominator. If  $Z(s)$  were infinite over all frequencies, the denominator of Equation 6 would reduce to 1 and the ideal desired signal gain shown in the numerator would be achieved. The fraction in the denominator of Equation 6 determines the frequency response. Equation 7 shows this as the loop gain equation:

$$\frac{Z(s)}{R_F + R_I NG} = \text{Loop Gain} \quad (7)$$

If  $20 \cdot \log(R_F + NG \cdot R_I)$  were superimposed on the open-loop transimpedance plot, the difference between the two would be the loop gain at a given frequency. Eventually,  $Z(s)$  rolls off to equal the denominator of Equation 7, at which point the loop gain has reduced to 1 (and the curves have intersected). This point of equality is where the amplifier's closed-loop frequency response given by Equation 6 will start to roll off, and is exactly analogous to the frequency at which the noise gain equals the open-loop voltage gain for a voltage-feedback op amp. The difference here is that the total impedance in the denominator of Equation 7 may be controlled separately from the desired signal gain (or NG).

The OPA685 is internally compensated to give a maximally flat frequency response for  $R_F = 402\Omega$  at  $NG = 8$  on  $\pm 5V$  supplies. Evaluating the denominator of Equation 7 (which is the feedback transimpedance) gives an optimal target of  $554\Omega$ . As the signal gain changes, the contribution of the  $NG \cdot R_I$  term in the feedback transimpedance will change, but the total can be held constant by adjusting  $R_F$ . Equation 8 gives an approximate equation for optimum  $R_F$  over signal gain:

$$R_F = 554\Omega - NG R_I \quad (8)$$

As the desired signal gain increases, this equation will eventually predict a negative  $R_F$ . A somewhat subjective limit to this adjustment can also be set by holding  $R_G$  to a minimum value of  $10\Omega$ . Lower values will load both the buffer stage at the input and the output stage if  $R_F$  gets too low, actually decreasing the bandwidth. Figure 15 shows the recommended  $R_F$  versus  $NG$  for both  $\pm 5V$  and a single  $+5V$  operation. The optimum target feedback impedance for  $+5V$  operation used in Equation 8 is  $532\Omega$ , while the typical buffer output impedance is  $23\Omega$ . The values for  $R_F$  versus gain shown here are approximately equal to the values used to generate the Typical Performance Curves. In some cases, the values used differ slightly from that shown here in that the values used in the Typical Performance Curves are also correcting for board parasitics not considered in the simplified analysis leading to Equation 8. The values shown in Figure 15 give a good starting point for design where bandwidth optimization is desired.

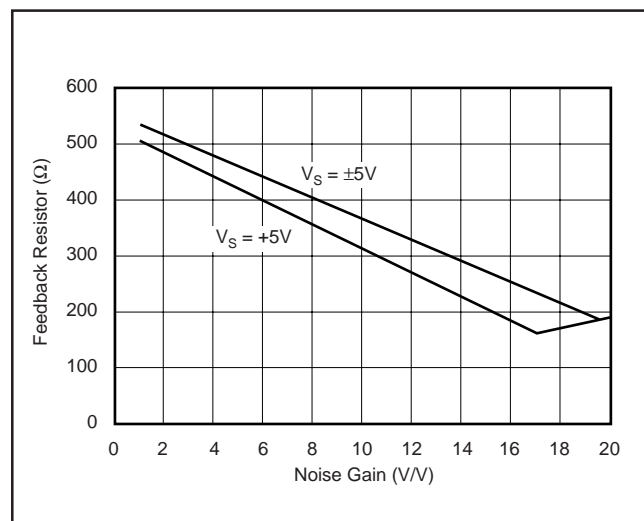

FIGURE 15. Recommended Feedback Resistor vs Noise Gain.

The total impedance presented to the inverting input may be used to adjust the closed-loop signal bandwidth. Inserting a series resistor between the inverting input and the summing junction will increase the feedback impedance (denominator of Equation 7), decreasing the bandwidth. The internal buffer output impedance for the OPA685 is slightly influenced by the source impedance looking out of the non-inverting input terminal. High source resistors will have the effect of increasing  $R_I$ , decreasing the bandwidth. For those single-supply applications which develop a midpoint bias at the non-inverting input through high valued resistors, the decoupling capacitor is essential for power supply ripple rejection, non-inverting input noise current shunting, and minimizing the high frequency value for  $R_I$  in Figure 14.

Inverting feedback optimization is somewhat complicated by the impedance matching requirement at the input, as shown in Figure 2. The resistor values shown in Table III should be used in this case.

## OUTPUT CURRENT AND VOLTAGE

The OPA685 provides output voltage and current capabilities that are consistent with driving doubly-terminated 50 $\Omega$  lines. For a 100 $\Omega$  load at the gain of +8 (see Figure 1), the total load is the parallel combination of the 100 $\Omega$  load and the 456 $\Omega$  total feedback network impedance. This 82 $\Omega$  load will require no more than 40mA output current to support the  $\pm 3.3$ V minimum output voltage swing specified for 100 $\Omega$  loads. This is well under the minimum +90/–60mA guaranteed specifications.

The specifications described above, though familiar in the industry, consider voltage and current limits separately. In many applications, it is the voltage • current or V-I product, which is more relevant to circuit operation. Refer to the “Output Voltage and Current Limitations” plot in the Typical Performance Curves. The X and Y axes of this graph show the zero-voltage output current limit and the zero-current output voltage limit, respectively. The four quadrants provide a more detailed view of the OPA685’s output drive capabilities. Superimposing resistor load lines onto the plot shows the available output voltage and current for specific loads.

The minimum specified output voltage and current over-temperature are set by worst-case simulations at the cold temperature extreme. Only at cold startup will the output current and voltage decrease to the numbers shown in the guaranteed tables. As the output transistors deliver power, their junction temperatures will increase, decreasing their  $V_{BE}$ s (increasing the available output voltage swing) and increasing their current gains (increasing the available output current). In steady-state operation, the available output voltage and current will always be greater than that shown in the over-temperature specifications since the output stage junction temperatures will be higher than the minimum specified operating ambient.

To maintain maximum output stage linearity, no output short-circuit protection is provided. This will not normally be a problem since most applications include a series matching resistor at the output that will limit the internal power dissipation if the output side of this resistor is shorted to ground. However, shorting the output pin directly to the adjacent positive power supply pin will, in most cases, destroy the amplifier. If additional short-circuit protection is required, consider a small series resistor in the power supply leads. This will, under heavy output loads, reduce the available output voltage swing. A 5 $\Omega$  series resistor in each power supply lead will limit the internal power dissipation to less than 1W for an output short circuit while decreasing the available output voltage swing only 0.25V for up to 50mA desired load currents. Always place the 0.1 $\mu$ F power supply decoupling capacitors directly on the supply pins after these supply current-limiting resistors.

## DRIVING CAPACITIVE LOADS

One of the most demanding, and yet very common, load conditions for an op amp is capacitive loading. Often, the capacitive load is the input of an A/D converter—including additional external capacitance which may be recommended to improve A/D linearity. A high speed, high open-loop gain amplifier like the OPA685 can be very susceptible to decreased stability and closed-loop response peaking when a capacitive load is placed directly on the output pin. When the amplifier’s open-loop output resistance is considered, this capacitive load introduces an additional pole in the signal path that can decrease the phase margin. Several external solutions to this problem have been suggested. When the primary considerations are frequency response flatness, pulse response fidelity and/or distortion, the simplest and most effective solution is to isolate the capacitive load from the feedback loop by inserting a series isolation resistor between the amplifier output and the capacitive load. This does not eliminate the pole from the loop response, but rather shifts it and adds a zero at a higher frequency. The additional zero acts to cancel the phase lag from the capacitive load pole, thus increasing the phase margin and improving stability.

The Typical Performance Curves show the recommended  $R_S$  versus capacitive load and the resulting frequency response at the load. Parasitic capacitive loads greater than 2pF can begin to degrade the performance of the OPA685. Long PC board traces, unmatched cables, and connections to multiple devices can easily cause this value to be exceeded. Always consider this effect carefully and add the recommended series resistor as close as possible to the OPA685 output pin (see Board Layout Guidelines).

## DISTORTION PERFORMANCE

The OPA685 provides good distortion performance into a 100 $\Omega$  load on  $\pm 5$ V supplies. Relative to alternative solutions, the OPA685 holds much lower distortion at higher frequencies (> 20MHz) than alternative solutions. Generally, until the fundamental signal reaches very high frequency or power levels, the 2nd harmonic will dominate the distortion with a negligible 3rd harmonic component. Focusing then on the 2nd harmonic, increasing the load impedance improves distortion directly. Remember, the total load includes the feedback network. In the non-inverting configuration (Figure 1), this is the sum of  $R_F + R_G$ , while in the inverting configuration, it is just  $R_F$ . Also, providing an additional supply decoupling capacitor (0.1 $\mu$ F) between the supply pins (for bipolar operation) improves the 2nd order distortion slightly (3dB to 6dB).



In most op amps, increasing the output voltage swing increases harmonic distortion directly. The Typical Performance Curves show the 2nd harmonic increasing at a little less than the expected 2x rate, while the 3rd harmonic increases at a little less than the expected 3x rate. Where the test power doubles, the difference between it and the 2nd harmonic decreases less than the expected 6dB, while the difference between it and the 3rd decreases by less than the expected 12dB.

The OPA685 has extremely low 3rd-order harmonic distortion. This also gives a high 2-tone, 3rd-order intermodulation intercept, as shown in the Typical Performance Curves. This intercept curve is defined at the 50Ω load when driven through a 50Ω matching resistor to allow direct comparisons to RF MMIC devices and is shown for both gains of ±8. There is a slight improvement in intercept by operating the OPA685 in the inverting mode. The output matching resistor attenuates the voltage swing from the output pin to the load by 6dB. If the OPA685 drives directly into the input of a high impedance device, such as an ADC, this 6dB attenuation is not taken. Under these conditions, the intercept will increase by a minimum 6dBm.

The intercept is used to predict the intermodulation products for two closely-spaced frequencies. If the two test frequencies,  $f_1$  and  $f_2$ , are specified in terms of average and delta frequency,  $f_O = (f_1 + f_2)/2$  and  $\Delta f = |f_2 - f_1|/2$ , the two 3rd-order, close-in spurious tones will appear at  $f_O \pm 3 \cdot \Delta f$ . The difference between two equal test-tone power levels and these intermodulation spurious power levels is given by  $\Delta dBc = 2 \cdot (IM3 - P_O)$ , where IM3 is the intercept taken from the Typical Performance Curve and  $P_O$  is the power level in dBm at the 50Ω load for one of the two closely-spaced test frequencies. For example, at 50MHz, gain of -8, the OPA685 has an intercept of 42dBm at a matched 50Ω load. If the full envelope of the two frequencies needs to be 2Vp-p, this requires each tone to be 4dBm. The 3rd-order intermodulation spurious tones will then be  $2 \cdot (42 - 4) = 76$ dBc below the test-tone power level (-72dBm). If this same 2Vp-p 2-tone envelope were delivered directly into the input of an ADC without the matching loss or the loading of the 50Ω network, the intercept would increase to at least 48dBm. With the same signal and gain conditions, but now driving directly into a light load, the 3rd-order spurious tones will then be at least  $2 \cdot (48 - 4) = 88$ dBc below the 4dBm test-tone power levels centered on 50MHz. Tests have shown that, in reality, they are much lower due to the lighter loading presented by most ADCs.

## NOISE PERFORMANCE

The OPA685 offers an excellent balance between voltage and current noise terms to achieve low output noise. The inverting current noise (19pA/√Hz) is lower than most other current-feedback op amps while the input voltage noise (1.7nV/√Hz) is lower than any unity gain stable, wideband, voltage-feedback op amp. This low input voltage noise was achieved at the price of a higher non-inverting input current noise (13pA/√Hz). As long as the AC source impedance looking out of the non-inverting node is less than 100Ω, this

current noise will not contribute significantly to the total output noise. The op amp input voltage noise and the two input current noise terms combine to give low output noise under a wide variety of operating conditions. Figure 16 shows the op amp noise analysis model with all the noise terms included. In this model, all noise terms are taken to be noise voltage or current density terms in either nV/√Hz or pA/√Hz.

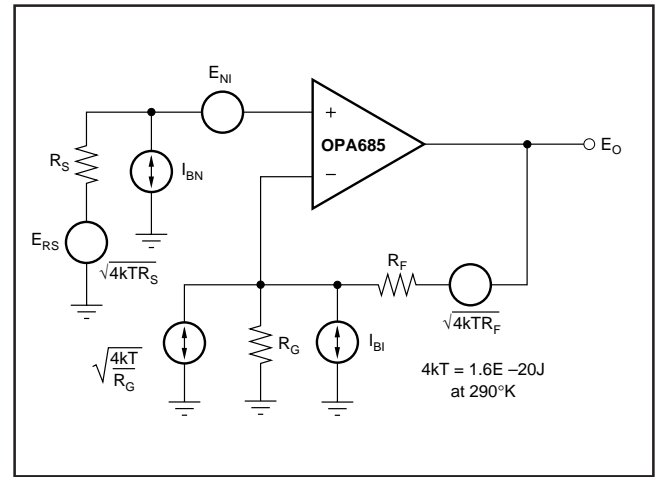

FIGURE 16. Op Amp Noise Figure Analysis Model.

The total output spot-noise voltage can be computed as the square root of the sum of all squared output noise voltage contributors. Equation 9 shows the general form for the output noise voltage using the terms shown in Figure 16.

$$(9)$$

$$E_O = \sqrt{(E_{NI}^2 + (I_{BN}R_S)^2 + 4kTR_S)G_N^2 + (I_{BI}R_F)^2 + 4kTR_F G_N}$$

Dividing this expression by the noise gain ( $NG = (1 + R_F/R_G)$ ) will give the equivalent input referred spot-noise voltage at the non-inverting input as shown in Equation 10:

$$(10)$$

$$E_N = \sqrt{E_{NI}^2 + (I_{BN}R_S)^2 + 4kTR_S + \left(\frac{I_{BI}R_F}{NG}\right)^2 + \frac{4kTR_F}{NG}}$$

Evaluating these two equations for the OPA685 circuit and component values shown in Figure 1 will give a total output spot-noise voltage of 18nV/√Hz and a total equivalent input spot-noise voltage of 2.3nV/√Hz. This total input referred spot-noise voltage is higher than the 1.7nV/√Hz specification for the op amp voltage noise alone. This reflects the noise added to the output by the inverting current noise times the feedback resistor. If the feedback resistor is reduced in high gain configurations (as suggested previously), the total input referred voltage noise given by Equation 10 will just approach the 1.7nV/√Hz of the op amp itself. For example, going to a gain of +20 (using  $R_F = 380\Omega$ ) will give a total input referred noise of 2.0nV/√Hz.

## DC ACCURACY AND OFFSET CONTROL

A current-feedback op amp like the OPA685 provides exceptional bandwidth in high gains, giving fast pulse settling but only moderate DC accuracy. The typical specifications show an input offset voltage comparable to high-speed voltage-feedback amplifiers, however, the two input bias currents are somewhat higher and are unmatched. Although bias current cancellation techniques are very effective with most voltage-feedback op amps, they do not generally reduce the output DC offset for wideband current-feedback op amps. Since the two input bias currents are unrelated in both magnitude and polarity, matching the source impedance looking out of each input to reduce their error contribution to the output is ineffective. Evaluating the configuration of Figure 1, using worst-case +25°C input offset voltage and the two input bias currents, gives a worst-case output offset range equal to:

$$\begin{aligned} & \pm(NG \cdot V_{OS}) + (I_{BN} \cdot R_S/2 \cdot NG) \pm(I_{BI} \cdot R_F) \\ \text{where } NG &= \text{non-inverting signal gain} \\ &= \pm(8 \cdot 3.5\text{mV}) + (90\mu\text{A} \cdot 25\Omega \cdot 8) \pm(402\Omega \cdot 100\mu\text{A}) \\ &= \pm 28\text{mV} + 18\text{mV} \pm 40\text{mV} \\ &= -50\text{mV} \rightarrow +86\text{mV} \end{aligned}$$

A fine-scale output offset null, or DC operating point adjustment, is often required. Numerous techniques are available for introducing DC offset control into an op amp circuit. Most simple adjustment techniques do not correct for temperature drift. It is possible to combine a lower speed, precision op amp with the OPA685 to get the DC accuracy of the precision op amp along with the signal bandwidth of the OPA685. Figure 17 shows a non-inverting  $G = +10$  circuit that holds an output offset voltage less than  $\pm 1.0\text{mV}$  over-temperature with  $> 300\text{MHz}$  bandwidth.

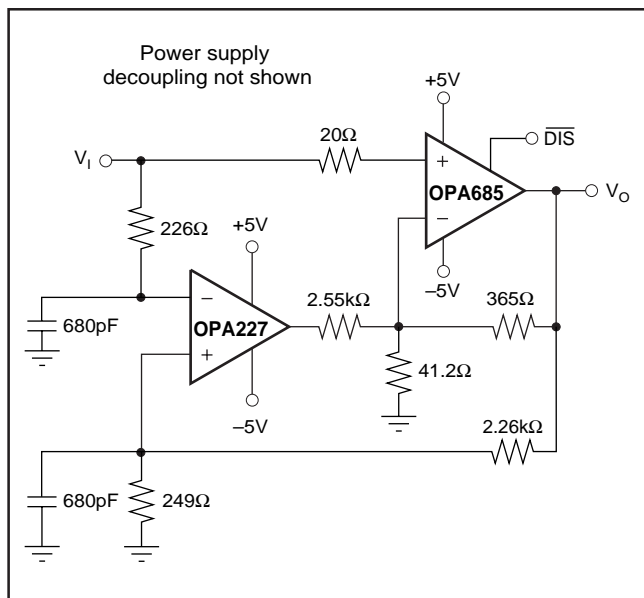

FIGURE 17. Wideband, Precision,  $G = +10$  Composite Amplifier.

This DC-coupled circuit provides very high signal bandwidth using the OPA685. At lower frequencies, the output voltage is attenuated by the signal gain and is compared to the original input voltage at the inputs of the OPA227 (a low cost, precision voltage-feedback op amp with  $8\text{MHz}$  gain bandwidth product). If these two don't agree at low frequencies, the OPA227 sums in a correcting current through the  $2.55\text{k}\Omega$  inverting summing path. Several design considerations will allow this circuit to be optimized. First, the feedback to the OPA227's non-inverting input must be precisely matched to the high-speed signal gain. Making the  $249\Omega$  resistor to ground an adjustable resistor would allow the low and high frequency gains to be precisely matched. Secondly, the crossover frequency region where the OPA227 passes control to the OPA685 must occur with exceptional phase linearity. These two issues reduce to designing for pole/zero cancellation in the overall transfer function. Using the  $2.55\text{k}\Omega$  resistor will nominally satisfy this requirement for the circuit of Figure 17. Perfect cancellation over process and temperature is not possible. However, this initial resistor setting and precise gain matching will minimize long-term pulse settling perturbations.

## DISABLE OPERATION

The OPA685 provides an optional disable feature that may be used either to reduce system power or to implement a simple channel multiplexing operation. If the  $\overline{\text{DIS}}$  control pin is left unconnected, the OPA685 will operate normally. To disable, the control pin must be asserted low. Figure 18 shows a simplified internal circuit for the disable control feature.

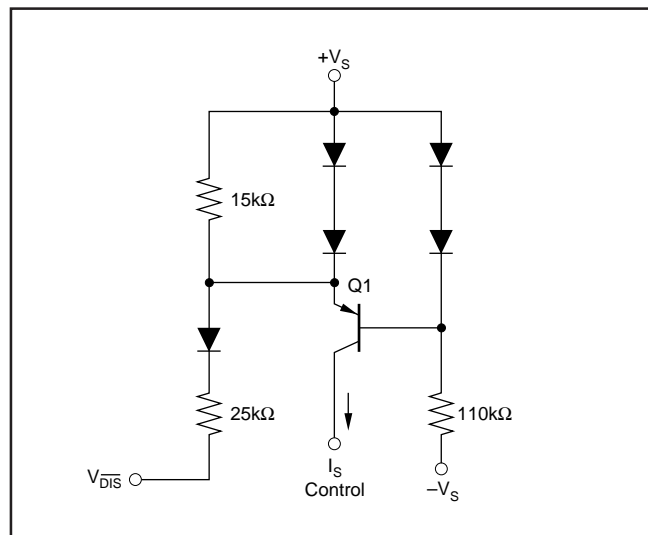

FIGURE 18. Simplified Disable Control Circuit.

In normal operation, base current to Q1 is provided through the  $110\text{k}\Omega$  resistor while the emitter current through the  $15\text{k}\Omega$  resistor sets up a voltage drop that is inadequate to turn on the two diodes in Q1's emitter. As  $\overline{\text{DIS}}$  is pulled LOW, additional current is pulled through the  $15\text{k}\Omega$  resistor, eventually turning on these two diodes ( $\approx 100\mu\text{A}$ ). At this

point, any further current pulled out of  $V_{DIS}$  goes through those diodes holding the emitter-base voltage of Q1 at approximately zero volts. This shuts off the collector current out of Q1, turning the amplifier off. The supply current in the disable mode are only those required to operate the circuit of Figure 18.

When disabled, the output and input nodes go to a high impedance state. If the OPA685 is operating in a gain of +1, this will show a very high impedance ( $3\text{pF} \parallel 1\text{M}\Omega$ ) at the output and exceptional signal isolation. If operating at a gain greater than +1, the total feedback network resistance ( $R_F + R_G$ ) will appear as the impedance looking back into the output, but the circuit will still show very high forward and reverse isolation. If configured as an inverting amplifier, the input and output will be connected through the feedback network resistance ( $R_F + R_G$ ), giving relatively poor input to output isolation.

One key parameter in disable operation is the output glitch when switching in and out of the disabled mode. Figure 19 shows these glitches for the circuit of Figure 1 with the input signal set to 0V. The glitch waveform at the output pin is plotted along with the  $\overline{DIS}$  pin voltage.

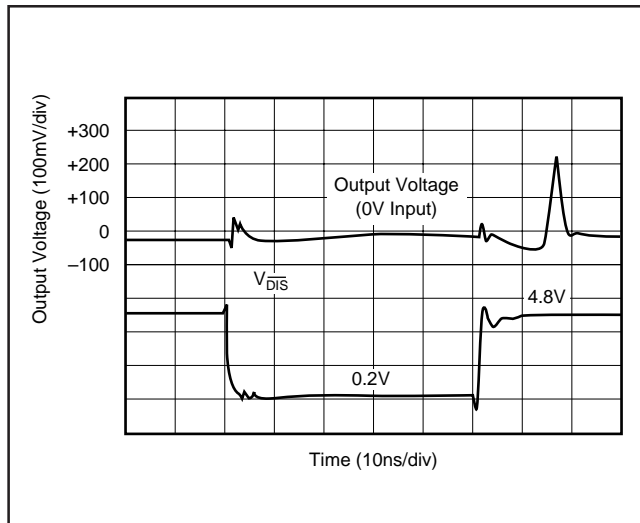

FIGURE 19. Disable/Enable Glitch.

The transition edge rate ( $dv/dt$ ) of the  $\overline{DIS}$  control line will influence this glitch. For the plot of Figure 19, the edge rate was reduced until no further reduction in glitch amplitude was observed. This approximately  $2\text{V/ns}$  maximum slew rate may be achieved by adding a simple RC filter into the  $\overline{DIS}$  pin from a higher speed logic line. If extremely fast transition logic is used, a  $2\text{k}\Omega$  series resistor between the logic gate and the  $\overline{DIS}$  input pin will provide adequate bandlimiting using just the parasitic input capacitance on the  $\overline{DIS}$  pin while still ensuring adequate logic level swing.

## THERMAL ANALYSIS

The OPA685 does not require external heatsinking for most applications. Maximum desired junction temperature will set the maximum allowed internal power dissipation as

described below. In no case should the maximum junction temperature be allowed to exceed  $175^\circ\text{C}$ .

Operating junction temperature ( $T_J$ ) is given by  $T_A + P_D \cdot \theta_{JA}$ . The total internal power dissipation ( $P_D$ ) is the sum of quiescent power ( $P_{DQ}$ ) and additional power dissipated in the output stage ( $P_{DL}$ ) to deliver load power. Quiescent power is simply the specified no-load supply current times the total supply voltage across the part.  $P_{DL}$  will depend on the required output signal and load. However, for a grounded resistive load,  $P_{DL}$  would be at a maximum when the output is fixed at a voltage equal to one-half of either supply voltage (for equal bipolar supplies). Under this condition,  $P_{DL} = V_S^2 / (4 \cdot R_L)$ , where  $R_L$  includes feedback network loading.

Note that it is the power in the output stage and not into the load that determines internal power dissipation.

As an absolute worst-case example, compute the maximum  $T_J$  using an OPA685N (SOT23-6 package) in the circuit of Figure 1 operating at the maximum specified ambient temperature of  $+85^\circ\text{C}$  and driving a grounded  $100\Omega$  load.

$$P_D = 10\text{V} \cdot 13.5\text{mA} + 5^2 / (4 \cdot (100\Omega \parallel 458\Omega)) = 211\text{mW}$$

$$\text{Maximum } T_J = +85^\circ\text{C} + (0.21\text{W} \cdot 150^\circ\text{C/W}) = 117^\circ\text{C}$$

This maximum operating junction temperature is well below most system level targets. Most applications will be lower since an absolute worst-case output stage power was assumed in this calculation.

## BOARD LAYOUT GUIDELINES

Achieving optimum performance with a high frequency amplifier like the OPA685 requires careful attention to board layout parasitics and external component types. Recommendations that will optimize performance include:

**a) Minimize parasitic capacitance to any AC ground for all of the signal I/O pins.** Parasitic capacitance on the output and inverting input pins can cause instability; on the non-inverting input, it can react with the source impedance to cause unintentional bandlimiting. To reduce unwanted capacitance, a window around the signal I/O pins should be opened in all of the ground and power planes around those pins. Otherwise, ground and power planes should be unbroken elsewhere on the board.

**b) Minimize the distance ( $< 0.25''$ ) from the power supply pins to high frequency  $0.1\mu\text{F}$  decoupling capacitors.** At the device pins, the ground and power plane layout should not be in close proximity to the signal I/O pins. Avoid narrow power and ground traces to minimize inductance between the pins and the decoupling capacitors. The power supply connections should always be decoupled with these capacitors. An optional supply-decoupling capacitor across the two power supplies (for bipolar operation) will improve 2nd harmonic distortion performance. Larger ( $2.2\mu\text{F}$  to  $6.8\mu\text{F}$ ) decoupling capacitors, effective at lower frequency, should also be used on the main supply pins. These may be placed somewhat farther from the device and may be shared among several devices in the same area of the PC board.

**c) Careful selection and placement of external components will preserve the high frequency performance of the OPA685.** Resistors should be a very low reactance type. Surface-mount resistors work best and allow a tighter overall layout. Metal-film and carbon composition, axially-leaded resistors can also provide good high frequency performance. Again, keep their leads and PC board trace length as short as possible. Never use wirewound-type resistors in a high frequency application. Since the output pin and inverting input pin are the most sensitive to parasitic capacitance, always position the feedback and series output resistor, if any, as close as possible to the output pin. Other network components, such as non-inverting input termination resistors, should also be placed close to the package. Where double-side component mounting is allowed, place the feedback resistor directly under the package on the other side of the board between the output and inverting input pins. The frequency response is primarily determined by the feedback resistor value, as described previously. Increasing its value will reduce the bandwidth, while decreasing it will give a more peaked frequency response. The  $402\Omega$  feedback resistor (used in the typical performance specifications at a gain of +8 on  $\pm 5V$  supplies) is a good starting point for design. Note that a  $523\Omega$  feedback resistor, rather than a direct short, is required for the unity gain follower application. A current-feedback op amp requires a feedback resistor—even in the unity gain follower configuration—to control stability.

**d) Connections to other wideband devices on the board may be made with short direct traces or through on-board transmission lines.** For short connections, consider the trace and the input to the next device as a lumped capacitive load. Relatively wide traces (50mils to 100mils) should be used, preferably with ground and power planes opened up around them. Estimate the total capacitive load and set  $R_S$  from the plot of “Recommended  $R_S$  vs Capacitive Load”. Low parasitic capacitive loads ( $< 5pF$ ) may not need an  $R_S$  since the OPA685 is nominally compensated to operate with a  $2pF$  parasitic load. If a long trace is required, and the 6dB signal loss intrinsic to a doubly-terminated transmission line is acceptable, implement a matched impedance transmission line using microstrip or stripline techniques (consult an ECL design handbook for microstrip and stripline layout techniques). A  $50\Omega$  environment is usually not necessary on board. In fact, a higher impedance environment will improve distortion as shown in the distortion versus load plots. With a characteristic board trace impedance defined (based on board material and trace dimensions), a matching series resistor into the trace from the output of the OPA685 is used. A terminating shunt resistor at the input of the destination device is used as well. Remember also that the terminating impedance will be the parallel combination of the shunt resistor and the input impedance of the destination device; this total effective impedance should be set to match the trace impedance. The

high output voltage and current capability of the OPA685 allows multiple destination devices to be handled as separate transmission lines, each with their own series and shunt terminations. If the 6dB attenuation of a doubly-terminated transmission line is unacceptable, a long trace can be series-terminated at the source end only. Treat the trace as a capacitive load in this case and set the series resistor value as shown in the plot of “ $R_S$  vs Capacitive Load”. This will not preserve signal integrity as well as a doubly-terminated line. If the input impedance of the destination device is low, there will be some signal attenuation due to the voltage divider formed by the series output into the terminating impedance.

**e) Socketing a high-speed part like the OPA685 is not recommended.** The additional lead length and pin-to-pin capacitance introduced by the socket can create an extremely troublesome parasitic network which can make it almost impossible to achieve a smooth, stable frequency response. Best results are obtained by soldering the OPA685 onto the board.

## INPUT AND ESD PROTECTION

The OPA685 is built using a very high-speed, complementary bipolar process. The internal junction breakdown voltages are relatively low for these very small geometry devices. These breakdowns are reflected in the Absolute Maximum Ratings table where an absolute maximum 13V supply is reported. All device pins have limited ESD protection using internal diodes to the power supplies as shown in Figure 20.

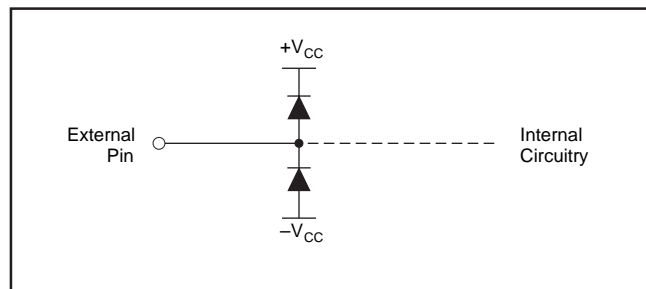

FIGURE 20. Internal ESD Protection.

These diodes also provide moderate protection to input overdrive voltages above the supplies. The protection diodes can typically support 30mA continuous current. Where higher currents are possible (e.g., in systems with  $\pm 15V$  supply parts driving into the OPA685), current-limiting series resistors should be added into the two inputs. Keep these resistor values as low as possible since high values degrade both noise performance and frequency response.