

6-channel high current driver

BA664

The BA664 is an IC with a built-in clamp diode, developed for the purpose of minimizing attachments, and contains a Darlington transistor array of six circuits with input resistance. Input and output are directed in the same direction by DIP Pin 14, with the layout optimized to facilitate mounting.

●Applications

Hammer solenoid drivers
Relay drivers
LED drivers
Small motor drivers
Lamp drivers

●Features

- 1) 6-circuit Darlington transistor array
- 2) Current of 100mA (Max.) can be driven.
- 3) Input and output are directed in the same direction, for easy mounting.
- 4) Can be coupled with MOS ICs.
- 5) High current transfer ratio.
- 6) High voltage withstanding values of 38V for input and 27V for output.
- 7) Clamp diode for inductive load drive built in.

●Block diagram

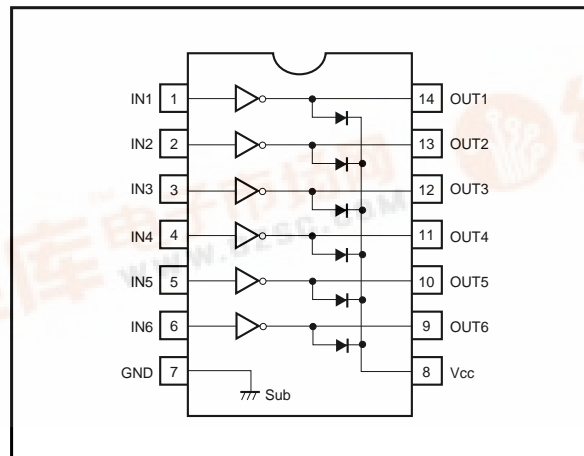

●Internal circuit configuration

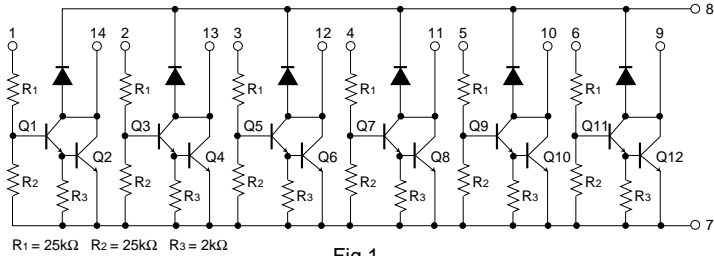

Fig.1

●Absolute maximum ratings (Ta = 25°C)

Parameter	Symbol	Limits	Unit
Power supply voltage	V _{CC}	27	V
Collector current	I _c	100	mA
Input pin withstanding voltage (+)	V ₊	38	V
Input pin withstanding voltage (-)	V ₋	- 0.5	V
Power dissipation	P _d	550*	mW
Operating temperature	T _{opr}	- 25 ~ + 75	°C
Storage temperature	T _{stg}	- 55 ~ + 125	°C

* Reduced by 5.5mW for each increase in Ta of 1°C over 25°C.

● Electrical characteristics (unless otherwise noted, Ta = 25°C)

Parameter	Symbol	Min.	Typ.	Max.	Unit	Conditions	Measurement circuit
Usage voltage range (output)	V _{CC}	—	—	20	V	—	—
Output leakage current	I _L	—	—	100	μA	V _C = 20V, V _{IN} = 0V	Fig.5
Collector saturation voltage	V _{CE(sat)}	—	1.4	2.2	V	I _{OUT} = 75mA, V _{IN} = 17V	Fig.8
Input current	I _{IN}	—	0.6	1.4	mA	V _{IN} = 35V, I _{OUT} = 0mA	Fig.6
Diode leakage current	I _D	—	—	100	μA	V _R = 20V	Fig.7
Diode forward voltage	V _F	—	1.2	—	V	I _F = 75mA	Fig.9

●Electrical characteristic curves

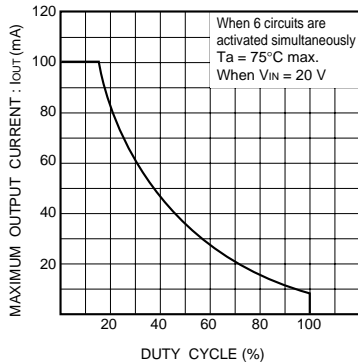

Fig.2 Output current vs. duty cycle

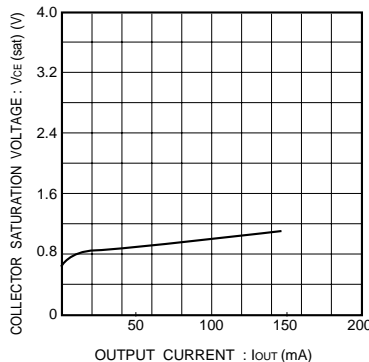

Fig.3 Output characteristics

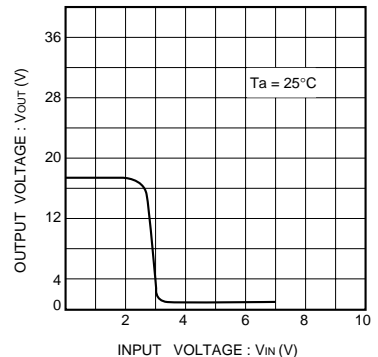

Fig.4 I / O characteristics

●Measurement circuits

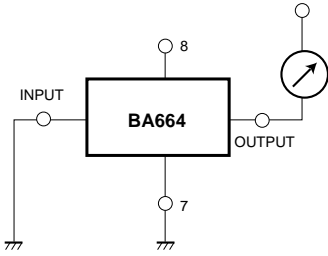

Fig.5

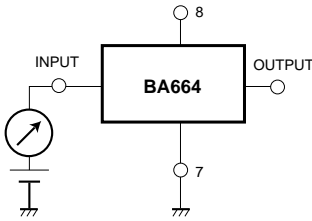

Fig.6

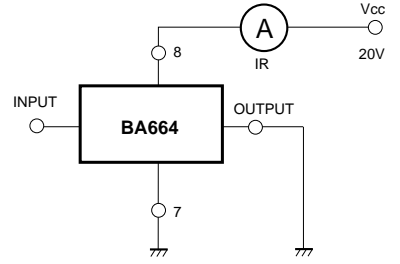

Fig.7

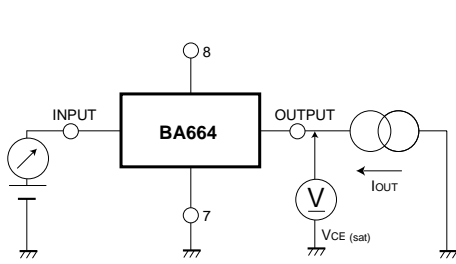

Fig.8

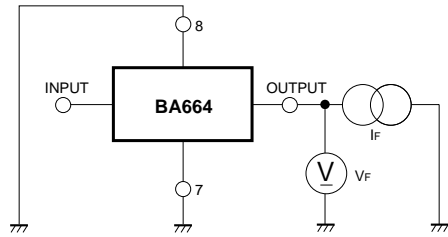
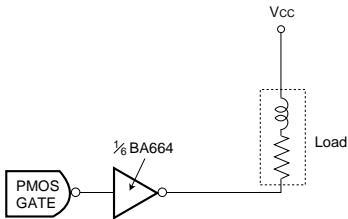

Fig.9

●Application example



Note) Connections should be made as shown in Figure 10 if inductive load is being driven. (Connect Pin 8 to power supply.)

Fig.10

●External dimensions (Units: mm)

