

6-channel high current driver

BA6256

The BA6256 is a low voltage, high current driver with six circuits, and is designed for applications such as LEDs, relays, solenoids, and other driver devices which operate at low voltages. This driver is particularly ideal for direct drive of CMOS controlled devices and other devices with a low input current of 5 μ A (typ.).

●Applications

Hammer solenoid drivers

Relay drivers

LED drivers

●Features

1) Output current of 400mA (Max.) can be driven.

3) High input impedance.

2) Equipped with strobe terminal.

●Block diagram

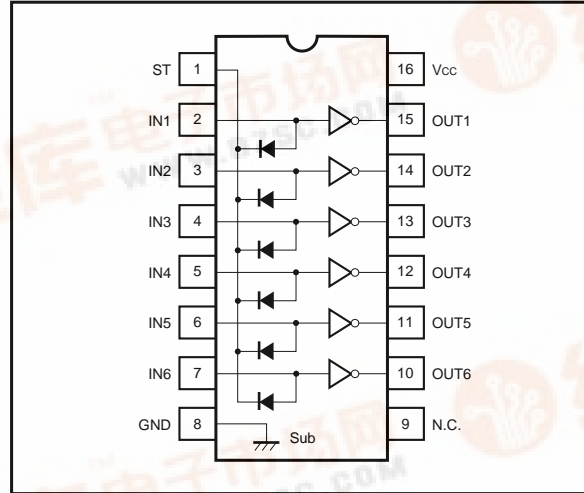

●Absolute maximum ratings (Ta = 25°C)

Parameter	Symbol	Limits	Unit
Power supply voltage	V _{CC}	11	V
Power dissipation	P _d	500*	mW
Input voltage	V _{IN}	-0.5 ~ V _{CC}	V
Output current	I _{o Max.}	450	mA
Operating temperature	T _{opr}	-25 ~ +75	°C
Storage temperature	T _{stg}	-55 ~ +125	°C

* Reduced by 5mW for each increase in Ta of 1°C over 25°C.

In this case, T_i = 15°C

●Electrical characteristics (unless otherwise noted, Ta = 25°C, Vcc = 6V)

Parameter	Symbol	Min.	Typ.	Max.	Unit	Conditions	Measurement circuit
Usage voltage range	V _{CC}	3	6	10	V	—	Fig.4
Input high level voltage	V _{IH}	3	—	—	V	I _{OUT} ≧ 200mA, when only 1 circuit is on	Fig.4
Input low level voltage	V _{IL}	—	—	1	V	I _{OUT} ≧ 100μA, when only 1 circuit is on	Fig.4
Output saturation voltage	V _{CE(sat)}	—	0.6	—	V	I _{OUT} ≧ 100μA, when only 1 circuit is on	Fig.5
Output current (1 circuit)	I _{OUT}	—	—	400	mA	—	—
Input current	I _{IN}	—	5	—	μA	I _{OUT} = 100mA, V _{IN} = 6V	Fig.6

●Internal circuit configuration

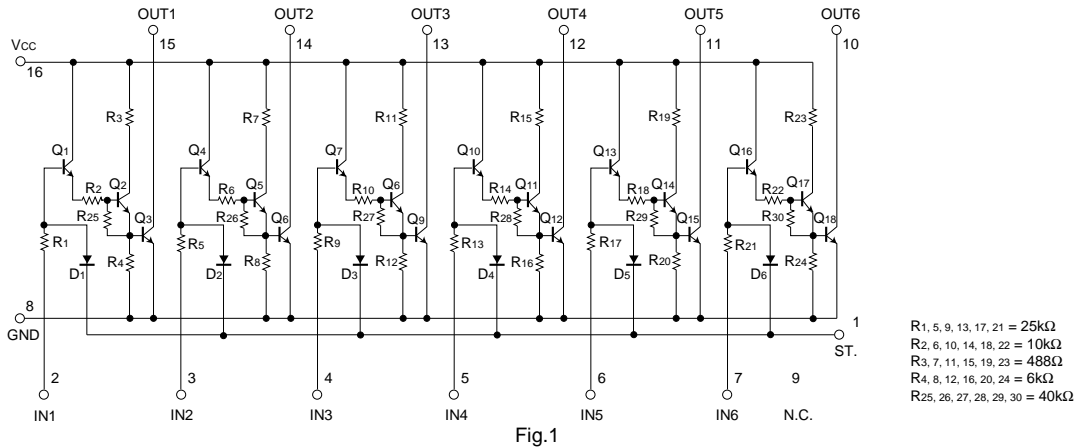

(Resistance values are typical values.)

●Electrical characteristic curves

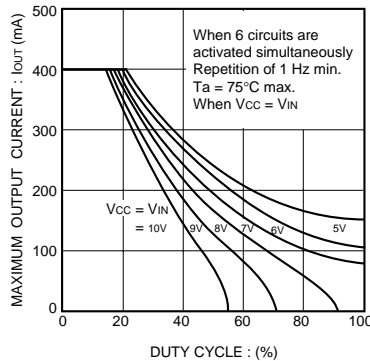
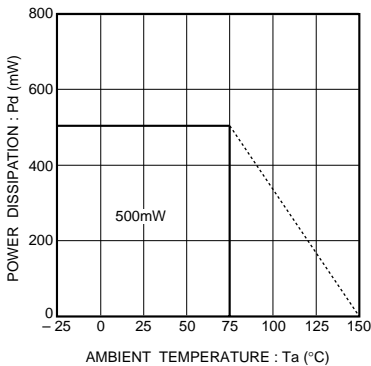

● Measurement circuits

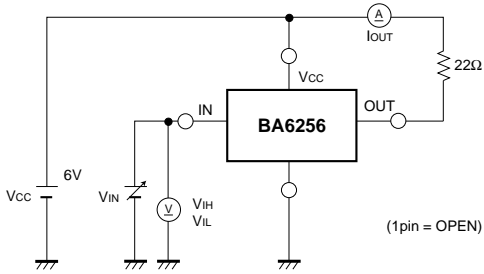

Fig.4

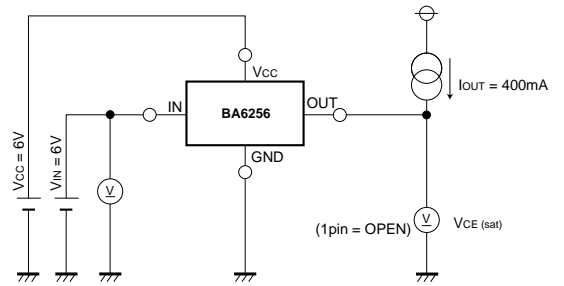

Fig.5

● External dimensions (Units: mm)

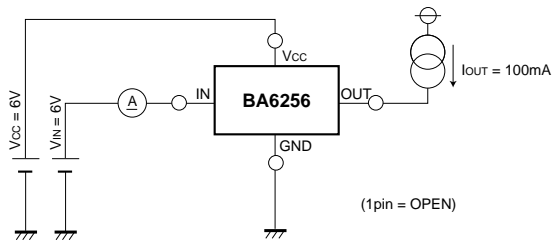

Fig.6

