

**1-LINE TO 18-LINE CLOCK DRIVER
WITH I²C CONTROL INTERFACE**

SCAS587B – JANUARY 1997 – REVISED MARCH 1998

- **High-Speed, Low-Skew 1-to-18 Clock Buffer for Synchronous DRAM (SDRAM) Clock Buffering Applications**
- **Output Skew, $t_{sk(o)}$, Less Than 250 ps**
- **Pulse Skew, $t_{sk(p)}$, Less Than 650 ps**
- **Supports up to Four Unbuffered SDRAM Dual Inline Memory Modules (DIMMs)**
- **I²C Serial Interface Provides Individual Enable Control for Each Output**
- **Operates at 3.3 V**
- **Distributed V_{CC} and Ground Pins Reduce Switching Noise**
- **ESD Protection Exceeds 2000 V Per MIL-STD-883, Method 3015**
- **Packaged in 48-Pin Shrink Small Outline (DL) Package**

description

The CDC318 is a high-performance clock buffer that distributes one input (A) to 18 outputs (Y) with minimum skew for clock distribution. The CDC318 operates from a 3.3-V power supply, and is characterized for operation from 0°C to 70°C.

The device provides a standard mode (100K-bits/s) I²C serial interface for device control. The implementation is as a slave/receiver. The device address is specified in the I²C device address table. Both of the I²C inputs (SDATA and SCLOCK) provide integrated pullup resistors (typically 140 kΩ) and are 5-V tolerant.

Three 8-bit I²C registers provide individual enable control for each of the outputs. All outputs default to enabled at powerup. Each output can be placed in a disabled mode with a low-level output when a low-level control bit is written to the control register. The registers are write only and must be accessed in sequential order (i.e., random access of the registers is not supported).

The CDC318 provides 3-state outputs for testing and debugging purposes. The outputs can be placed in a high-impedance state via the output-enable (OE) input. When OE is high, all outputs are in the operational state. When OE is low, the outputs are placed in a high-impedance state. OE provides an integrated pullup resistor.

**DL PACKAGE
(TOP VIEW)**

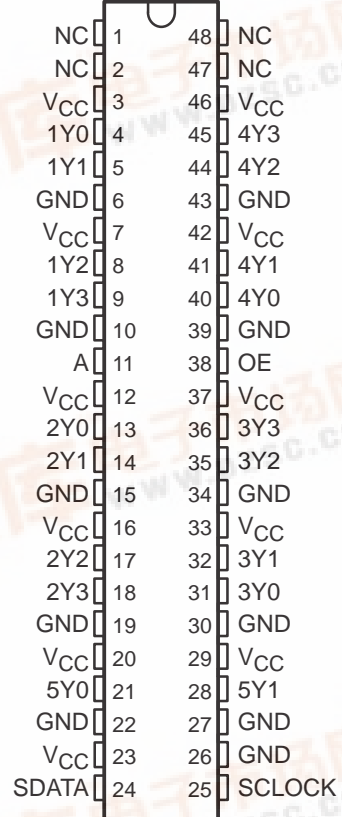

NC – No internal connection

Please be aware that an important notice concerning availability, standard warranty, and use in critical applications of Texas Instruments semiconductor products and disclaimers thereto appears at the end of this data sheet.



Intel is a trademark of Intel Corporation

PRODUCTION DATA information is current as of publication date. Products conform to specifications per the terms of Texas Instruments standard warranty. Production processing does not necessarily include testing of all parameters.



CDC318
1-LINE TO 18-LINE CLOCK DRIVER
WITH I²C CONTROL INTERFACE
 SCAS587B – JANUARY 1997 – REVISED MARCH 1998

FUNCTION TABLE

INPUTS		OUTPUTS				
OE	A	1Y0-1Y3	2Y0-2Y3	3Y0-3Y3	4Y0-4Y3	5Y0-5Y1
L	X	Hi-Z	Hi-Z	Hi-Z	Hi-Z	Hi-Z
H	L	L	L	L	L	L
H	H	H†	H†	H†	H†	H†

† The function table assumes that all outputs are enabled via the appropriate I²C configuration register bit. If the output is disabled via the appropriate configuration bit, then the output is driven to a low state, regardless of the state of the A input.

logic diagram (positive logic)

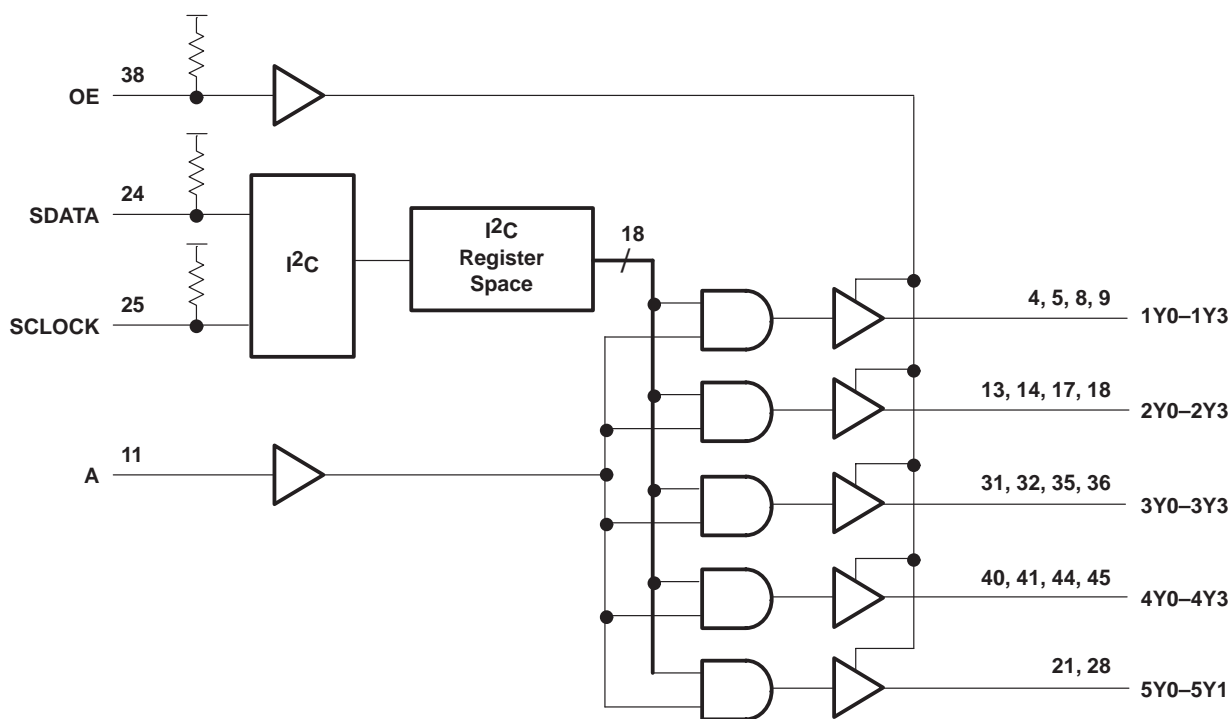

Terminal Functions

TERMINAL NAME	TERMINAL NO.	I/O	DESCRIPTION
1Y0–1Y3	4, 5, 8, 9	O	3.3-V SDRAM byte 0 clock outputs
2Y0–2Y3	13, 14, 17, 18	O	3.3-V SDRAM byte 1 clock outputs
3Y0–3Y3	31, 32, 35, 36	O	3.3-V SDRAM byte 2 clock outputs
4Y0–4Y3	40, 41, 44, 45	O	3.3-V SDRAM byte 3 clock outputs
5Y0–5Y1	21, 28	O	3.3-V clock outputs provided for feedback control of external phase-locked loops (PLLs)
A	11	I	Clock input
OE	38	I	Output enable. When asserted, OE puts all outputs in a high-impedance state. A nominal 140-k Ω pullup resistor is internally integrated.
SCLOCK	25	I	I ² C serial clock input. A nominal 140-k Ω pullup resistor is internally integrated.
SDATA	24	I/O	Bidirectional I ² C serial data input/output. A nominal 140-k Ω pullup resistor is internally integrated.
GND	6, 10, 15, 19, 22, 26, 27, 30, 34, 39, 43		Ground
NC	1, 2, 47, 48		No internal connection. Reserved for future use.
V _{CC}	3, 7, 12, 16, 20, 23, 29, 33, 37, 42, 46		3.3-V power supply

I²C DEVICE ADDRESS

A7	A6	A5	A4	A3	A2	A1	A0 (R/W)
H	H	L	H	L	L	H	—

I²C BYTE 0-BIT DEFINITION†

BIT	DEFINITION	DEFAULT VALUE
7	2Y3 enable (pin 18)	H
6	2Y2 enable (pin 17)	H
5	2Y1 enable (pin 14)	H
4	2Y0 enable (pin 13)	H
3	1Y3 enable (pin 9)	H
2	1Y2 enable (pin 8)	H
1	1Y1 enable (pin 5)	H
0	1Y0 enable (pin 4)	H

† When the value of the bit is high, the output is enabled. When the value of the bit is low, the output is forced to a low state. The default value of all bits is high.

CDC318

1-LINE TO 18-LINE CLOCK DRIVER WITH I²C CONTROL INTERFACE

SCAS587B – JANUARY 1997 – REVISED MARCH 1998

I²C BYTE 1-BIT DEFINITION†

BIT	DEFINITION	DEFAULT VALUE
7	4Y3 enable (pin 45)	H
6	4Y2 enable (pin 44)	H
5	4Y1 enable (pin 41)	H
4	4Y0 enable (pin 40)	H
3	3Y3 enable (pin 36)	H
2	3Y2 enable (pin 35)	H
1	3Y1 enable (pin 32)	H
0	3Y0 enable (pin 31)	H

† When the value of the bit is high, the output is enabled.
When the value of the bit is low, the output is forced to a low state. The default value of all bits is high.

I²C BYTE 2-BIT DEFINITION†

BIT	DEFINITION	DEFAULT VALUE
7	5Y1 enable (pin 28)	H
6	5Y0 enable (pin 21)	H
5	Reserved	H
4	Reserved	H
3	Reserved	H
2	Reserved	H
1	Reserved	H
0	Reserved	H

† When the value of the bit is high, the output is enabled.
When the value of the bit is low, the output is forced to a low state. The default value of all bits is high.

CDC318
1-LINE TO 18-LINE CLOCK DRIVER
WITH I²C CONTROL INTERFACE
 SCAS587B – JANUARY 1997 – REVISED MARCH 1998

absolute maximum ratings over operating free-air temperature range (unless otherwise noted)†

Supply voltage range, V_{CC}	-0.5 V to 4.6 V
Input voltage range, V_I (see Note 1)	-0.5 V to 4.6 V
Input voltage range, V_I (SCLOCK, SDATA) (see Note 1)	-0.5 V to 6.5 V
Output voltage range, V_O (SDATA) (see Note 1)	-0.5 V to 6.5 V
Voltage range applied to any output in the high or power-off state, V_O	-0.5 V to $V_{CC} + 0.5$ V
Current into any output in the low state (except SDATA), I_O	48 mA
Current into SDATA in the low state, I_O	12 mA
Input clamp current, I_{IK} ($V_I < 0$) (SCLOCK)	-50 mA
Output clamp current, I_{OK} ($V_O < 0$) (SDATA)	-50 mA
Package thermal impedance, θ_{JA} (see Notes 2 and 3)	84°C/W
Storage temperature range, T_{stg}	-65°C to 150°C
Lead temperature 1,6 mm (1/16 inch) from case for 10 seconds	260°C

† Stresses beyond those listed under “absolute maximum ratings” may cause permanent damage to the device. These are stress ratings only, and functional operation of the device at these or any other conditions beyond those indicated under “recommended operating conditions” is not implied. Exposure to absolute-maximum-rated conditions for extended periods may affect device reliability.

- NOTES: 1. The input and output negative-voltage ratings may be exceeded if the input and output clamp-current ratings are observed.
 2. The package thermal impedance is calculated in accordance with EIA/JEDEC Std JESD51, except for through-hole packages, which use a trace length of zero. The absolute maximum power dissipation allowed at $T_A = 55^\circ\text{C}$ (in still air) is 1.2 W.
 3. Thermal impedance (θ_{JA}) can be considerably lower if the device is soldered on the PCB board with a copper layer underneath the package. A simulation on a PCB board (3 in. \times 3 in.) with two internal copper planes (1 oz. cu, 0.036 mm thick) and 0.071 mm cu (202) in area underneath the package, resulted in $\theta_{JA} = 60^\circ\text{C/W}$. This would allow 1.2 W total power dissipation at $T_A = 70^\circ\text{C}$.

recommended operating conditions (see Note 4)

		MIN	TYP	MAX	UNIT
V_{CC}	3.3-V core supply voltage	3.135		3.465	V
V_{IH}	High-level input voltage	A, OE	2	$V_{CC} + 0.3$	V
		SDATA, SCLOCK (see Note 3)	2.2	5.5	V
V_{IL}	Low-level input voltage	A, OE	-0.3	0.8	V
		SDATA, SCLOCK (see Note 3)	0	1.04	V
I_{OH}	High-level output current			1	mA
I_{OL}	Low-level output current			-1	mA
r_i	Input resistance to V_{CC}		140		k Ω
$f(\text{SCL})$	SCLOCK frequency			100	kHz
$t(\text{BUS})$	Bus free time	4.7			μs
$t_{su}(\text{START})$	START setup time	4.7			μs
$t_h(\text{START})$	START hold time	4			μs
$t_w(\text{SCLL})$	SCLOCK low pulse duration	4.7			μs
$t_w(\text{SCLH})$	SCLOCK high pulse duration	4			μs
$t_r(\text{SDATA})$	SDATA input rise time			1000	ns
$t_f(\text{SDATA})$	SDATA input fall time			300	ns
$t_{su}(\text{SDATA})$	SDATA setup time	250			ns
$t_h(\text{SDATA})$	SDATA hold time	0			ns
$t_{su}(\text{STOP})$	STOP setup time	4			μs
T_A	Operating free-air temperature	0		70	$^\circ\text{C}$

NOTE 4: The CMOS-level inputs fall within these limits: $V_{IH} \text{ min} = 0.7 \times V_{CC}$ and $V_{IL} \text{ max} = 0.3 \times V_{CC}$.

CDC318
1-LINE TO 18-LINE CLOCK DRIVER
WITH I²C CONTROL INTERFACE

SCAS587B – JANUARY 1997 – REVISED MARCH 1998

electrical characteristics over recommended operating free-air temperature range (unless otherwise noted)

PARAMETER			TEST CONDITIONS	MIN	TYP	MAX	UNIT	
V _{IK}	Input clamp voltage		V _{CC} = 3.135 V, I _I = -18 mA			-1.2	V	
V _{OH}	High-level output voltage	Y outputs	V _{CC} = 3.135 V, I _{OH} = -1 mA	2.4			V	
V _{OL}	Low-level output voltage	Y outputs	V _{CC} = 3.135 V, I _{OL} = 1 mA			0.4	V	
		SDATA	V _{CC} = 3.135 V	I _{OL} = 3 mA		0.4		
				I _{OL} = 6 mA		0.6		
I _{OH}	High-level output current	SDATA	V _{CC} = 3.135 V, V _O = V _{CC} MAX			20	μA	
		Y outputs	V _{CC} = 3.135 V, V _O = 2 V	-54		-126	mA	
			V _{CC} = 3.3 V, V _O = 2.6 V		-54			
			V _{CC} = 3.465 V, V _O = 3.135 V	-21		-46		
I _{OL}	Low-level output current	Y outputs	V _{CC} = 3.135 V, V _O = 1 V	49		118	mA	
			V _{CC} = 3.3 V, V _O = 0.7 V		58			
			V _{CC} = 3.465 V, V _O = 0.4 V	23		53		
I _{IH}	High-level input current	A	V _{CC} = 3.465 V, V _I = V _{CC}			5	μA	
		OE				20		
		SCLOCK, SDATA				20		
I _{IL}	Low-level input current	A	V _{CC} = 3.465 V, V _I = GND			-5	μA	
		OE				-10		-50
		SCLOCK, SDATA				-10		-50
I _{OZ}	High-impedance-state output current		V _{CC} = 3.465 V, V _O = 3.465 V or 0			±10	μA	
I _{off}	Off-state current	SCLOCK, SDATA	V _{CC} = 0, V _I = 0 V to 5.5 V			50	μA	
I _{CC}	Supply current		V _{CC} = 3.465 V, I _O = 0		0.2	0.5	mA	
ΔI _{CC}	Change in supply current		V _{CC} = 3.135 V to 3.465 V, One input at V _{CC} - 0.6 V, All other inputs at V _{CC} or GND			500	μA	
	Dyanmic I _{CC} at 100 MHz		V _{CC} = 3.465 V, C _L = 20 pF,		360		mA	
C _I	Input capacitance		V _I = V _{CC} or GND, V _{CC} = 3.3 V		4		pF	
C _O	Output capacitance		V _O = V _{CC} or GND, V _{CC} = 3.3 V		6		pF	
C _{I/O}	SDATA I/O capacitance		V _{I/O} = V _{CC} or GND, V _{CC} = 3.3 V		7		pF	

CDC318
1-LINE TO 18-LINE CLOCK DRIVER
WITH I²C CONTROL INTERFACE
SCAS587B – JANUARY 1997 – REVISED MARCH 1998

switching characteristics over recommended operating conditions

PARAMETER		FROM	TO	TEST CONDITIONS	MIN	MAX	UNIT
t _{PLH}	Low-to-high level propagation delay time	A	Y		1.2	4.5	ns
		SCLOCK↓	SDATA valid	V _{CC} = 3.3 V ±0.185 V, See Figure 3		2	μs
t _{PLH}	Low-to-high level propagation delay time	SDATA↑	Y	V _{CC} = 3.3 V ±0.185 V, See Figure 3		150	ns
t _{PHL}	High-to-low level propagation delay time	A	Y		1.2	4.5	ns
		SCLOCK↓	SDATA valid	V _{CC} = 3.3 V ±0.185 V, See Figure 3		2	μs
t _{PHL}	High-to-low level propagation delay time	SDATA↑	Y	V _{CC} = 3.3 V ±0.185 V, See Figure 3		150	ns
t _{PZH}	Enable time to the high level	OE	Y		1	7	ns
t _{PZL}	Enable time to the low level				1	7	
t _{PHZ}	Disable time from the high level	OE	Y		1	7	ns
t _{PLZ}	Disable time from the low level				1	7	
t _{sk(o)}	Skew time	A	Y			250	ps
t _{sk(p)}	Skew time	A	Y			650	ps
t _{sk(pr)}	Skew time	A	Y			1	ns
t _r	Rise time		Y		0.5	2.4	ns
t _r	Rise time (see Note 5 and Figure 3)	SDATA		C _L = 10 pF	6		ns
				C _L = 400 pF		950	
t _f	Fall time		Y		0.5	2.3	ns
t _f	Fall time (see Note 5 and Figure 3)	SDATA		C _L = 10 pF	20		ns
				C _L = 400 pF		250	

NOTE 5: This parameter has a lower limit than BUS specification. This allows use of series resistors for current spike protection.

CDC318
1-LINE TO 18-LINE CLOCK DRIVER
WITH I²C CONTROL INTERFACE
 SCAS587B – JANUARY 1997 – REVISED MARCH 1998

PARAMETER MEASUREMENT INFORMATION

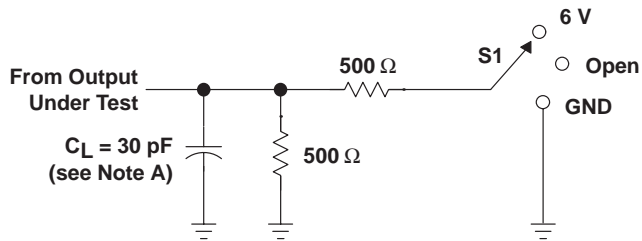

TEST	S1
t _{PLH} /t _{PHL}	Open
t _{PLZ} /t _{PZL}	6 V
t _{PHZ} /t _{PZH}	GND

LOAD CIRCUIT FOR t_{pd} AND t_{sk}

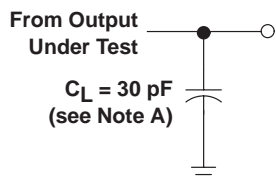

LOAD CIRCUIT FOR t_r AND t_f

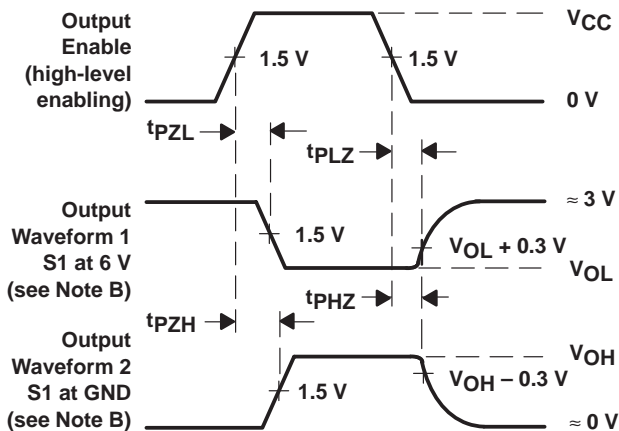
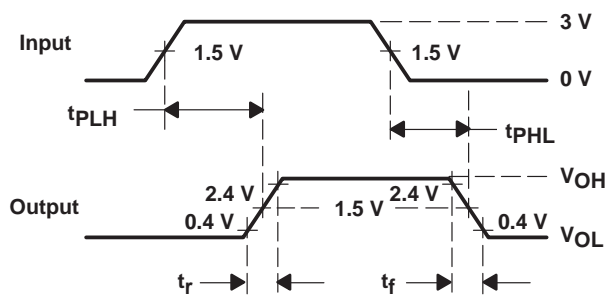
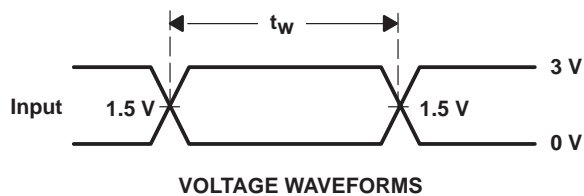

- NOTES: A. C_L includes probe and jig capacitance.
 B. Waveform 1 is for an output with internal conditions such that the output is low except when disabled by the output control. Waveform 2 is for an output with internal conditions such that the output is high except when disabled by the output control.
 C. All input pulses are supplied by generators having the following characteristics: PRR ≤ 10 MHz, Z_O = 50 Ω, t_r ≤ 2.5 ns, t_f ≤ 2.5 ns.
 D. The outputs are measured one at a time with one transition per measurement.

Figure 1. Load Circuit and Voltage Waveforms

PARAMETER MEASUREMENT INFORMATION

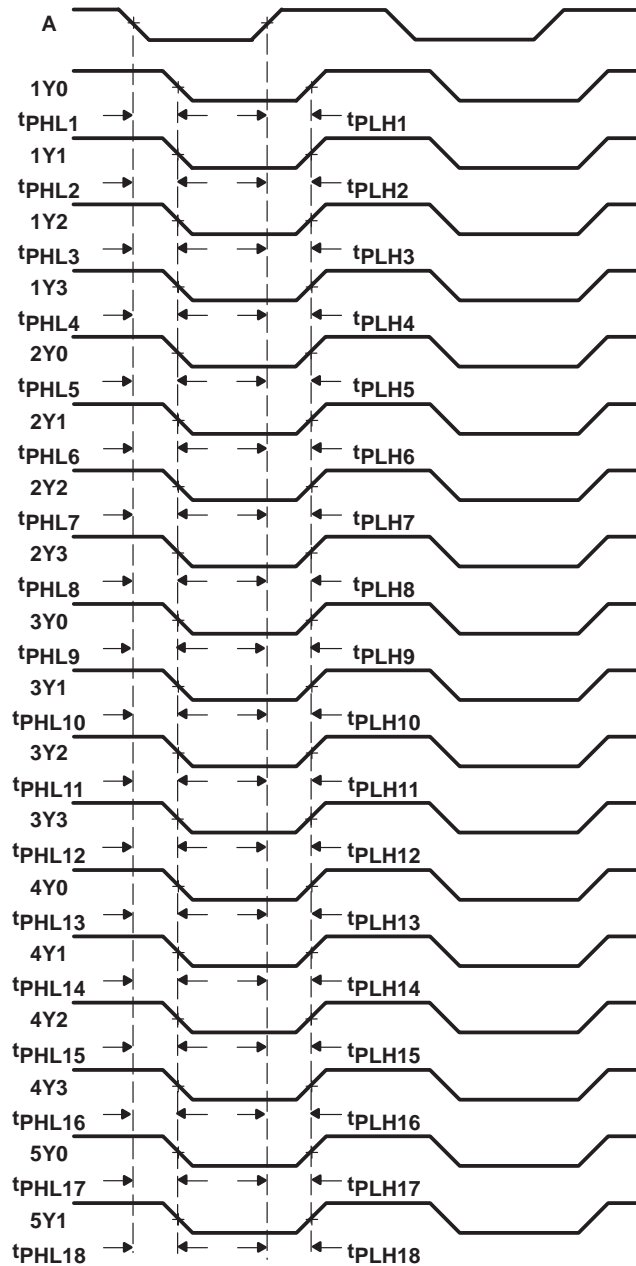

- NOTES: A. Output skew, $t_{sk(o)}$, is calculated as the greater of:
- The difference between the fastest and slowest of t_{PLHn} ($n = 1:18$)
 - The difference between the fastest and slowest of t_{PHLn} ($n = 1:18$)
- B. Pulse skew, $t_{sk(p)}$, is calculated as the greater of $|t_{PLHn} - t_{PHLn}|$ ($n = 1:18$)
- C. Process skew, $t_{sk(pr)}$, is calculated as the greater of:
- The difference between the fastest and slowest of t_{PLHn} ($n = 1:18$) across multiple devices under identical operating conditions
 - The difference between the fastest and slowest of t_{PHLn} ($n = 1:18$) across multiple devices under identical operating conditions

Figure 2. Waveforms for Calculation of $t_{sk(o)}$, $t_{sk(p)}$, $t_{sk(pr)}$

PARAMETER MEASUREMENT INFORMATION

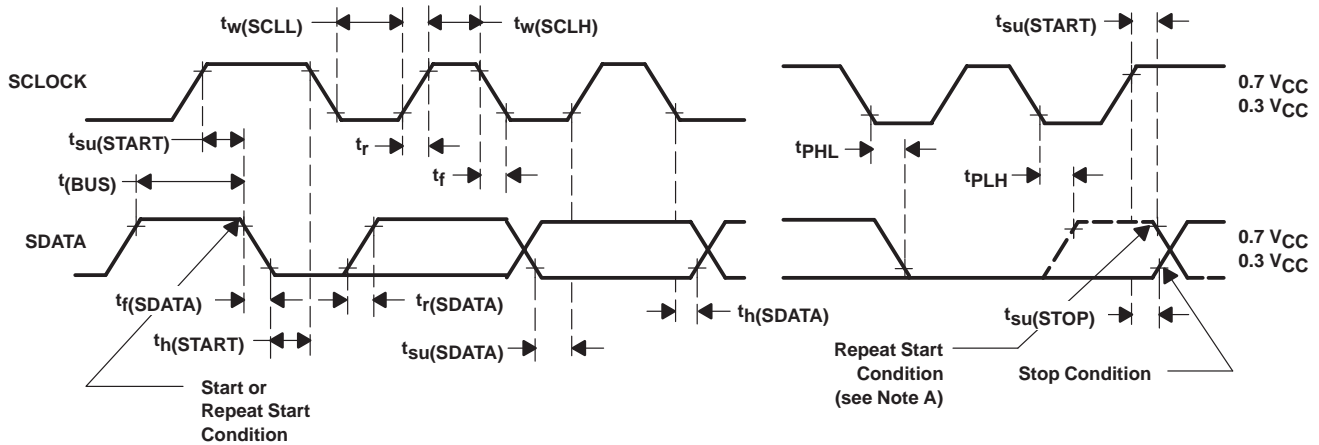
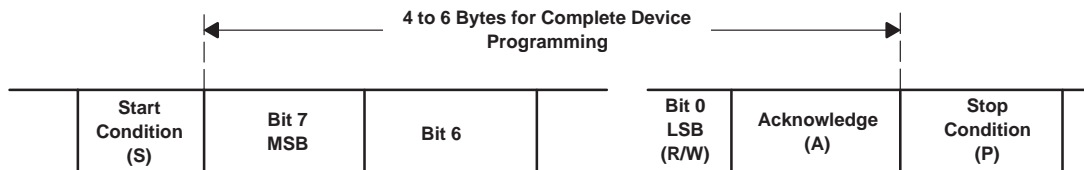
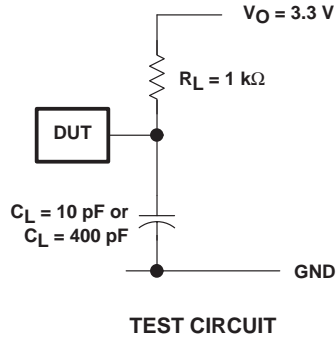

VOLTAGE WAVEFORMS

BYTE	DESCRIPTION
1	I ² C address
2	Command (dummy value, ignored)
3	Byte count (dummy value, ignored)
4	I ² C data byte 0
5	I ² C data byte 1
6	I ² C data byte 2

NOTES: A. The repeat start condition is not supported.
 B. All input pulses are supplied by generators having the following characteristics: PRR ≤ 100 kHz, Z_O = 50 Ω, t_r ≥ 10 ns, t_f ≥ 10 ns.

Figure 3. Propagation Delay Times, t_r and t_f

CDC318
1-LINE TO 18-LINE CLOCK DRIVER
WITH I²C CONTROL INTERFACE

SCAS587B – JANUARY 1997 – REVISED MARCH 1998

MECHANICAL INFORMATION

DL (R-PDSO-G)**

PLASTIC SMALL-OUTLINE PACKAGE

48 PIN SHOWN

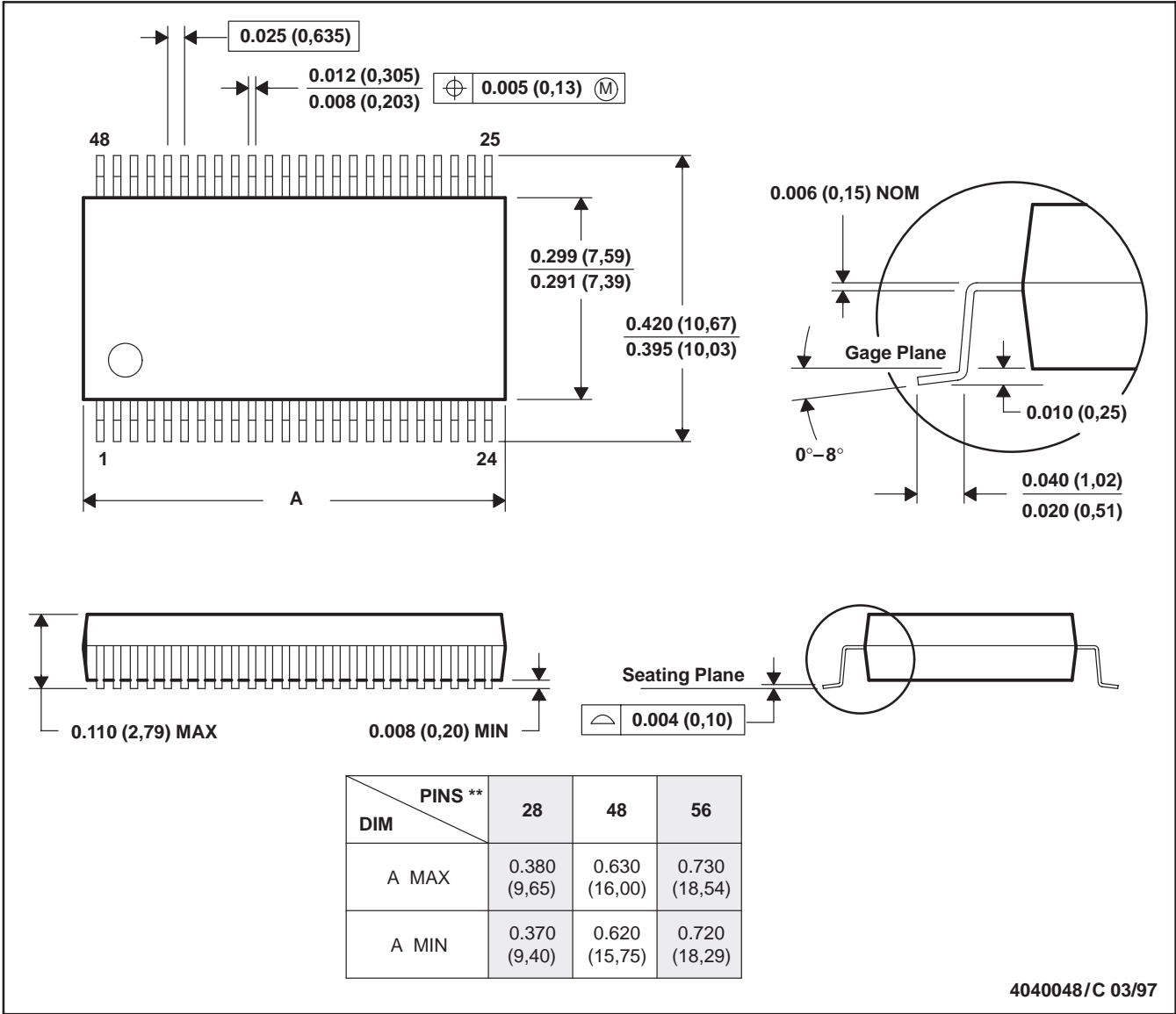

- NOTES: A. All linear dimensions are in inches (millimeters).
 B. This drawing is subject to change without notice.
 C. Body dimensions do not include mold flash or protrusion not to exceed 0.006 (0,15).
 D. Falls within JEDEC MO-118

IMPORTANT NOTICE

Texas Instruments and its subsidiaries (TI) reserve the right to make changes to their products or to discontinue any product or service without notice, and advise customers to obtain the latest version of relevant information to verify, before placing orders, that information being relied on is current and complete. All products are sold subject to the terms and conditions of sale supplied at the time of order acknowledgement, including those pertaining to warranty, patent infringement, and limitation of liability.

TI warrants performance of its semiconductor products to the specifications applicable at the time of sale in accordance with TI's standard warranty. Testing and other quality control techniques are utilized to the extent TI deems necessary to support this warranty. Specific testing of all parameters of each device is not necessarily performed, except those mandated by government requirements.

CERTAIN APPLICATIONS USING SEMICONDUCTOR PRODUCTS MAY INVOLVE POTENTIAL RISKS OF DEATH, PERSONAL INJURY, OR SEVERE PROPERTY OR ENVIRONMENTAL DAMAGE ("CRITICAL APPLICATIONS"). TI SEMICONDUCTOR PRODUCTS ARE NOT DESIGNED, AUTHORIZED, OR WARRANTED TO BE SUITABLE FOR USE IN LIFE-SUPPORT DEVICES OR SYSTEMS OR OTHER CRITICAL APPLICATIONS. INCLUSION OF TI PRODUCTS IN SUCH APPLICATIONS IS UNDERSTOOD TO BE FULLY AT THE CUSTOMER'S RISK.

In order to minimize risks associated with the customer's applications, adequate design and operating safeguards must be provided by the customer to minimize inherent or procedural hazards.

TI assumes no liability for applications assistance or customer product design. TI does not warrant or represent that any license, either express or implied, is granted under any patent right, copyright, mask work right, or other intellectual property right of TI covering or relating to any combination, machine, or process in which such semiconductor products or services might be or are used. TI's publication of information regarding any third party's products or services does not constitute TI's approval, warranty or endorsement thereof.