

# SN54HC138, SN74HC138 3-LINE TO 8-LINE DECODERS/DEMULTIPLEXERS

SCLS107C – DECEMBER 1982 – REVISED MAY 1997

- **Designed Specifically for High-Speed Memory Decoders and Data Transmission Systems**
- **Incorporate Three Enable Inputs to Simplify Cascading and/or Data Reception**
- **Package Options Include Plastic Small-Outline (D), Thin Shrink Small-Outline (PW), and Ceramic Flat (W) Packages, Ceramic Chip Carriers (FK), and Standard Plastic (N) and Ceramic (J) 300-mil DIPs**

## description

The 'HC138 are designed to be used in high-performance memory-decoding or data-routing applications requiring very short propagation delay times. In high-performance memory systems, these decoders can be used to minimize the effects of system decoding. When employed with high-speed memories utilizing a fast enable circuit, the delay times of these decoders and the enable time of the memory are usually less than the typical access time of the memory. This means that the effective system delay introduced by the decoders is negligible.

The conditions at the binary-select inputs at the three enable inputs select one of eight output lines. Two active-low and one active-high enable inputs reduce the need for external gates or inverters when expanding. A 24-line decoder can be implemented without external inverters and a 32-line decoder requires only one inverter. An enable input can be used as a data input for demultiplexing applications.

The SN54HC138 is characterized for operation over the full military temperature range of  $-55^{\circ}\text{C}$  to  $125^{\circ}\text{C}$ . The SN74HC138 is characterized for operation from  $-40^{\circ}\text{C}$  to  $85^{\circ}\text{C}$ .

SN54HC138 . . . J OR W PACKAGE  
SN74HC138 . . . D, N, OR PW PACKAGE  
(TOP VIEW)

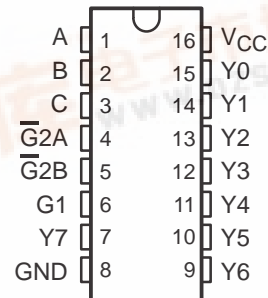

SN54HC138 . . . FK PACKAGE  
(TOP VIEW)

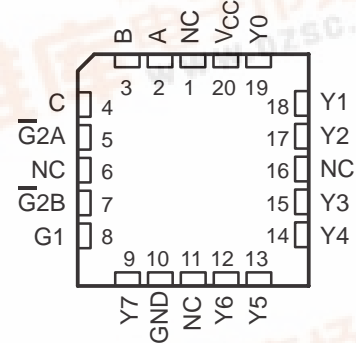

NC – No internal connection

Please be aware that an important notice concerning availability, standard warranty, and use in critical applications of Texas Instruments semiconductor products and disclaimers thereto appears at the end of this data sheet.



PRODUCTION DATA information is current as of publication date. Products conform to specifications per the terms of Texas Instruments standard warranty. Production processing does not necessarily include testing of all parameters.

# SN54HC138, SN74HC138 3-LINE TO 8-LINE DECODERS/DEMULTIPLEXERS

SCLS107C – DECEMBER 1982 – REVISED MAY 1997

FUNCTION TABLE

INPUTS						OUTPUTS							
ENABLE			SELECT										
G1	$\overline{G2A}$	$\overline{G2B}$	C	B	A	Y0	Y1	Y2	Y3	Y4	Y5	Y6	Y7
X	H	X	X	X	X	H	H	H	H	H	H	H	H
X	X	H	X	X	X	H	H	H	H	H	H	H	H
L	X	X	X	X	X	H	H	H	H	H	H	H	H
H	L	L	L	L	L	L	H	H	H	H	H	H	H
H	L	L	L	L	H	H	L	H	H	H	H	H	H
H	L	L	L	H	L	H	H	L	H	H	H	H	H
H	L	L	L	H	H	H	H	L	H	H	H	H	H
H	L	L	H	L	L	H	H	H	H	L	H	H	H
H	L	L	H	L	H	H	H	H	H	H	L	H	H
H	L	L	H	H	L	H	H	H	H	H	H	L	H
H	L	L	H	H	H	H	H	H	H	H	H	H	L

## logic symbols (alternatives)†

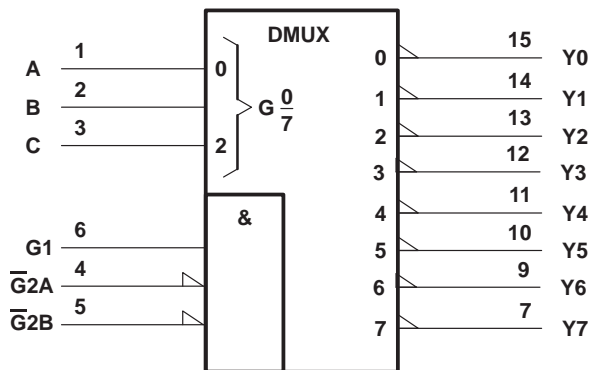
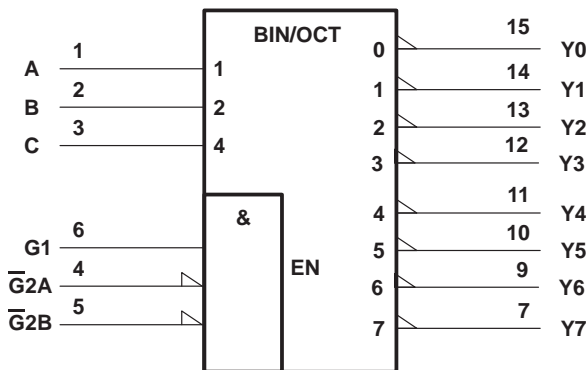

† These symbols are in accordance with ANSI/IEEE Std 91-1984 and IEC Publication 617-12. Pin numbers shown are for the D, J, N, PW, and W packages.



# SN54HC138, SN74HC138

## 3-LINE TO 8-LINE DECODERS/DEMULTIPLEXERS

SCLS107C – DECEMBER 1982 – REVISED MAY 1997

### recommended operating conditions

		SN54HC138			SN74HC138			UNIT
		MIN	NOM	MAX	MIN	NOM	MAX	
V <sub>CC</sub>	Supply voltage	2	5	6	2	5	6	V
V <sub>IH</sub>	High-level input voltage	V <sub>CC</sub> = 2 V	1.5		1.5		V	
		V <sub>CC</sub> = 4.5 V	3.15		3.15			
		V <sub>CC</sub> = 6 V	4.2		4.2			
V <sub>IL</sub>	Low-level input voltage	V <sub>CC</sub> = 2 V	0	0.5	0	0.5	V	
		V <sub>CC</sub> = 4.5 V	0	1.35	0	1.35		
		V <sub>CC</sub> = 6 V	0	1.8	0	1.8		
V <sub>I</sub>	Input voltage	0	V <sub>CC</sub>		0	V <sub>CC</sub>		V
V <sub>O</sub>	Output voltage	0	V <sub>CC</sub>		0	V <sub>CC</sub>		V
t <sub>t</sub>	Input transition (rise and fall) time	V <sub>CC</sub> = 2 V	0	1000	0	1000	ns	
		V <sub>CC</sub> = 4.5 V	0	500	0	500		
		V <sub>CC</sub> = 6 V	0	400	0	400		
T <sub>A</sub>	Operating free-air temperature	-55		125	-40		85	°C

### electrical characteristics over recommended operating free-air temperature range (unless otherwise noted)

PARAMETER	TEST CONDITIONS	V <sub>CC</sub>	T <sub>A</sub> = 25°C			SN54HC138		SN74HC138		UNIT
			MIN	TYP	MAX	MIN	MAX	MIN	MAX	
V <sub>OH</sub>	V <sub>I</sub> = V <sub>IH</sub> or V <sub>IL</sub>	I <sub>OH</sub> = -20 μA	2 V	1.9	1.998	1.9	1.9	V		
			4.5 V	4.4	4.499	4.4	4.4			
			6 V	5.9	5.999	5.9	5.9			
		I <sub>OH</sub> = -4 mA	4.5 V	3.98	4.3	3.7	3.84			
			6 V	5.48	5.8	5.2	5.34			
V <sub>OL</sub>	V <sub>I</sub> = V <sub>IH</sub> or V <sub>IL</sub>	I <sub>OL</sub> = 20 μA	2 V	0.002	0.1	0.1	0.1	V		
			4.5 V	0.001	0.1	0.1	0.1			
			6 V	0.001	0.1	0.1	0.1			
		I <sub>OL</sub> = 4 mA	4.5 V	0.17	0.26	0.4	0.33			
			6 V	0.15	0.26	0.4	0.33			
I <sub>I</sub>	V <sub>I</sub> = V <sub>CC</sub> or 0	6 V	±0.1	±100	±1000	±1000	nA			
I <sub>CC</sub>	V <sub>I</sub> = V <sub>CC</sub> or 0, I <sub>O</sub> = 0	6 V	8		160	80	μA			
C <sub>i</sub>		2 V to 6 V	3	10	10	10	pF			

# SN54HC138, SN74HC138 3-LINE TO 8-LINE DECODERS/DEMULTIPLEXERS

SCLS107C – DECEMBER 1982 – REVISED MAY 1997

switching characteristics over recommended operating free-air temperature range,  $C_L = 50$  pF (unless otherwise noted) (see Figure 1)

PARAMETER	FROM (INPUT)	TO (OUTPUT)	$V_{CC}$	$T_A = 25^\circ\text{C}$			SN54HC138		SN74HC138		UNIT
				MIN	TYP	MAX	MIN	MAX	MIN	MAX	
$t_{pd}$	A, B, or C	Any Y	2 V		67	180		270		225	ns
			4.5 V		18	36		54		45	
			6 V		15	31		46		38	
	Enable	Any Y	2 V		66	155		235		195	
			4.5 V		18	31		47		39	
			6 V		15	26		40		33	
$t_t$		Any	2 V		38	75		110		95	ns
			4.5 V		8	15		22		19	
			6 V		6	13		19		16	

operating characteristics,  $T_A = 25^\circ\text{C}$

PARAMETER	TEST CONDITIONS	TYP	UNIT
$C_{pd}$ Power dissipation capacitance	No load	85	pF

## PARAMETER MEASUREMENT INFORMATION

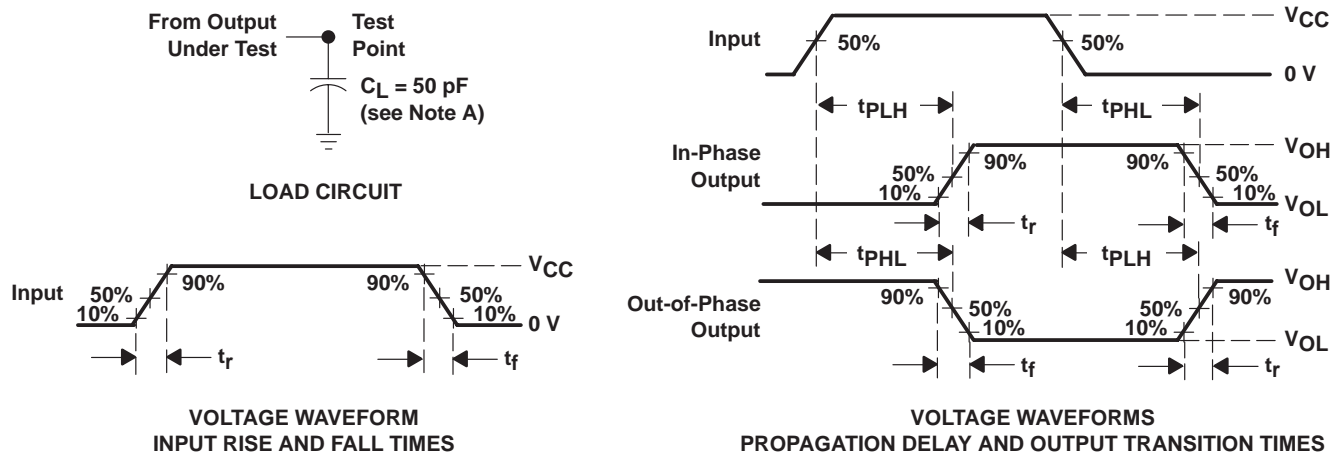

- NOTES:
- $C_L$  includes probe and test-fixture capacitance.
  - Phase relationships between waveforms were chosen arbitrarily. All input pulses are supplied by generators having the following characteristics:  $PRR \leq 1$  MHz,  $Z_O = 50 \Omega$ ,  $t_r = 6$  ns,  $t_f = 6$  ns.
  - The outputs are measured one at a time with one input transition per measurement.
  - $t_{PLH}$  and  $t_{PHL}$  are the same as  $t_{pd}$ .

Figure 1. Load Circuit and Voltage Waveforms

## **IMPORTANT NOTICE**

Texas Instruments and its subsidiaries (TI) reserve the right to make changes to their products or to discontinue any product or service without notice, and advise customers to obtain the latest version of relevant information to verify, before placing orders, that information being relied on is current and complete. All products are sold subject to the terms and conditions of sale supplied at the time of order acknowledgement, including those pertaining to warranty, patent infringement, and limitation of liability.

TI warrants performance of its semiconductor products to the specifications applicable at the time of sale in accordance with TI's standard warranty. Testing and other quality control techniques are utilized to the extent TI deems necessary to support this warranty. Specific testing of all parameters of each device is not necessarily performed, except those mandated by government requirements.

CERTAIN APPLICATIONS USING SEMICONDUCTOR PRODUCTS MAY INVOLVE POTENTIAL RISKS OF DEATH, PERSONAL INJURY, OR SEVERE PROPERTY OR ENVIRONMENTAL DAMAGE ("CRITICAL APPLICATIONS"). TI SEMICONDUCTOR PRODUCTS ARE NOT DESIGNED, AUTHORIZED, OR WARRANTED TO BE SUITABLE FOR USE IN LIFE-SUPPORT DEVICES OR SYSTEMS OR OTHER CRITICAL APPLICATIONS. INCLUSION OF TI PRODUCTS IN SUCH APPLICATIONS IS UNDERSTOOD TO BE FULLY AT THE CUSTOMER'S RISK.

In order to minimize risks associated with the customer's applications, adequate design and operating safeguards must be provided by the customer to minimize inherent or procedural hazards.

TI assumes no liability for applications assistance or customer product design. TI does not warrant or represent that any license, either express or implied, is granted under any patent right, copyright, mask work right, or other intellectual property right of TI covering or relating to any combination, machine, or process in which such semiconductor products or services might be or are used. TI's publication of information regarding any third party's products or services does not constitute TI's approval, warranty or endorsement thereof.