

SN54F243, SN74F243 QUADRUPLE BUS TRANSCEIVERS WITH 3-STATE OUTPUTS

SDFS086 – MARCH 1987 – REVISED OCTOBER 1993

- Asynchronous Communication Between Data Buses
- Local Bus-Latch Capability
- True Logic
- Package Options Include Plastic Small-Outline Packages, Ceramic Chip Carriers, and Standard Plastic and Ceramic 300-mil DIPs

description

These quadruple bus transceivers are designed for asynchronous communications between data buses. The control function implementation allows for maximum flexibility in timing. These devices allow data transmission from the A bus to the B bus or from the B bus to the A bus depending upon the logic levels at the output-enable (OEBA and OEAB) inputs. The output-enable inputs can be used to disable the device so that the buses are effectively isolated.

The dual-enable configuration gives the quadruple bus transceivers the capability to store data by simultaneous enabling of OEBA and OEAB. Each output reinforces its input in this transceiver configuration. Thus, when both control inputs are enabled and all other data sources to the two sets of bus lines are at high impedance, both sets of bus lines (eight in all) remain at their states. The 4-bit codes appearing on the two sets of buses will be identical for the 'F243.

The SN54F243 is characterized for operation over the full military temperature range of -55°C to 125°C . The SN74F243 is characterized for operation from 0°C to 70°C .

SN54F243 . . . J PACKAGE
SN74F243 . . . D OR N PACKAGE
(TOP VIEW)

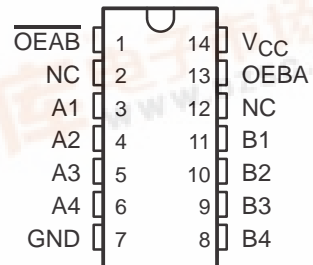

SN54F243 . . . FK PACKAGE
(TOP VIEW)

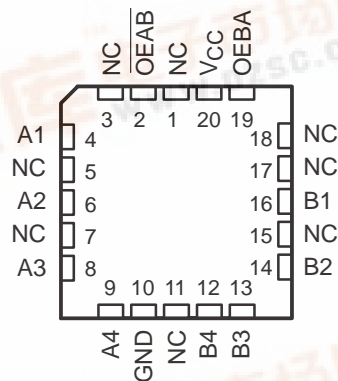

NC – No internal connection

FUNCTION TABLE

INPUTS		FUNCTION
OEAB	OEBA	
L	L	A to B
H	H	B to A
H	L	Isolation
L	H	Latch A and B (A = B)



SN54F243, SN74F243 QUADRUPLE BUS TRANSCEIVERS WITH 3-STATE OUTPUTS

SDFS086 – MARCH 1987 – REVISED OCTOBER 1993

logic symbol†

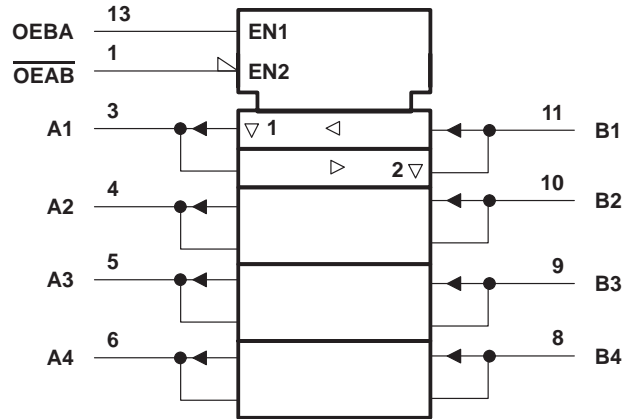

† This symbol is in accordance with ANSI/IEEE Std 91-1984 and IEC Publication 617-12.

logic diagram (positive logic)

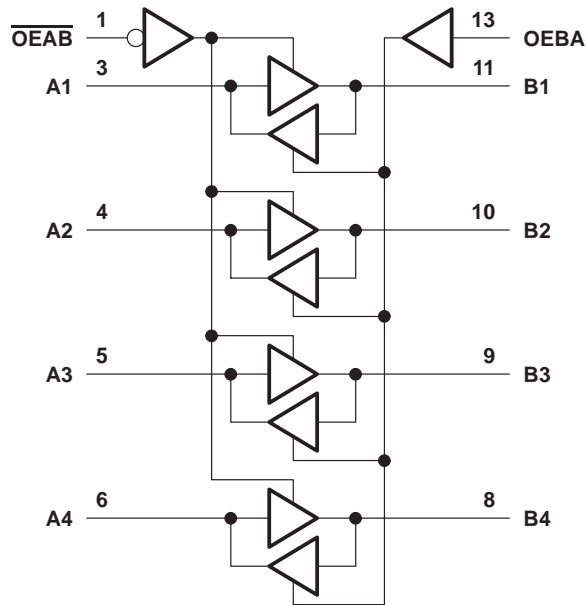

Pin numbers shown are for the D, J, and N packages.

SN54F243, SN74F243
QUADRUPLE BUS TRANSCEIVERS
WITH 3-STATE OUTPUTS

SDFS086 – MARCH 1987 – REVISED OCTOBER 1993

absolute maximum ratings over operating free-air temperature range (unless otherwise noted)†

Supply voltage range, V_{CC}	–0.5 V to 7 V
Input voltage range, V_I (see Note 1)	–1.2 V to 7 V
Input current range	–30 mA to 5 mA
Voltage range applied to any output in the disabled or power-off state	–0.5 V to 5.5 V
Voltage range applied to any output in the high state	–0.5 V to V_{CC}
Current into any output in the low state: SN54F243	96 mA
SN74F243	128 mA
Operating free-air temperature range: SN54F243	–55°C to 125°C
SN74F243	0°C to 70°C
Storage temperature range	–65°C to 150°C

† Stresses beyond those listed under “absolute maximum ratings” may cause permanent damage to the device. These are stress ratings only and functional operation of the device at these or any other conditions beyond those indicated under “recommended operating conditions” is not implied. Exposure to absolute-maximum-rated conditions for extended periods may affect device reliability.

NOTE 1: The input voltage ratings may be exceeded provided the input current ratings are observed.

recommended operating conditions

		SN54F243			SN74F243			UNIT
		MIN	NOM	MAX	MIN	NOM	MAX	
V_{CC}	Supply voltage	4.5	5	5.5	4.5	5	5.5	V
V_{IH}	High-level input voltage	2			2			V
V_{IL}	Low-level input voltage			0.8			0.8	V
I_{IK}	Input clamp current			–18			–18	mA
I_{OH}	High-level output current			–12			–15	mA
I_{OL}	Low-level output current			48			64	mA
T_A	Operating free-air temperature	–55		125	0		70	°C

SN54F243, SN74F243 QUADRUPLE BUS TRANSCEIVERS WITH 3-STATE OUTPUTS

SDFS086 – MARCH 1987 – REVISED OCTOBER 1993

electrical characteristics over recommended operating free-air temperature range (unless otherwise noted)

PARAMETER	TEST CONDITIONS		SN54F243			SN74F243			UNIT
			MIN	TYP†	MAX	MIN	TYP†	MAX	
V_{IK}	$V_{CC} = 4.5\text{ V}$, $I_I = -18\text{ mA}$		-1.2			-1.2			V
V_{OH}	$V_{CC} = 4.5\text{ V}$	$I_{OH} = -3\text{ mA}$	2.4	3.3		2.4	3.3		V
		$I_{OH} = -12\text{ mA}$	2	3.2					
		$I_{OH} = -15\text{ mA}$				2	3.1		
	$V_{CC} = 4.75\text{ V}$	$I_{OH} = -3\text{ mA}$				2.7			
V_{OL}	$V_{CC} = 4.5\text{ V}$	$I_{OL} = 48\text{ mA}$	0.38	0.55					V
		$I_{OL} = 64\text{ mA}$				0.42	0.55		
I_I	A or B port	$V_{CC} = 5.5\text{ V}$	$V_I = 5.5\text{ V}$		1		1		mA
	Control inputs		$V_I = 7\text{ V}$		0.1		0.1		
I_{IH}	A or B port‡	$V_{CC} = 5.5\text{ V}$	$V_I = 2.7\text{ V}$		70		70		μA
	Control inputs				20		20		
I_{IL}^\ddagger		$V_{CC} = 5.5\text{ V}$	$V_I = 0.5\text{ V}$		-1		-1.6		mA
I_{OS}^\S		$V_{CC} = 5.5\text{ V}$	$V_O = 0$		-100	-225	-100	-225	mA
I_{CC}	$V_{CC} = 5.5\text{ V}$, See Note 2	Outputs high	64	80	64	80			mA
		Outputs low	64	90	64	90			
		Outputs disabled	71	90	71	90			

† All typical values are at $V_{CC} = 5\text{ V}$, $T_A = 25^\circ\text{C}$.

‡ For I/O ports, the parameters I_{IH} and I_{IL} include the off-state output current.

§ Not more than one output should be shorted at a time, and the duration of the short circuit should not exceed one second.

NOTE 2: I_{CC} is measured either with all transceivers enabled in only one direction or all transceivers disabled.

switching characteristics (see Note 3)

PARAMETER	FROM (INPUT)	TO (OUTPUT)	$V_{CC} = 5\text{ V}$, $C_L = 50\text{ pF}$, $R_L = 500\ \Omega$, $T_A = 25^\circ\text{C}$			$V_{CC} = 4.5\text{ V to }5.5\text{ V}$, $C_L = 50\text{ pF}$, $R_L = 500\ \Omega$, $T_A = \text{MIN to MAX}^\parallel$				UNIT
			'F243			SN54F243		SN74F243		
			MIN	TYP	MAX	MIN	MAX	MIN	MAX	
t_{PLH}	A or B	B or A	1.7	3.6	5.2	1.2	6.5	1.2	6.2	ns
t_{PHL}			1.7	3.6	5.2	1.2	8.5	1.2	6.5	
t_{PZH}	Enable	A or B	1.2	3.9	5.7	1.2	8	1.2	6.7	ns
t_{PZL}			1.2	5.4	7.5	1.2	10.5	1.2	8.5	
t_{PHZ}	Disable	A or B	1.2	4.1	6	1	7.5	1	7	ns
t_{PLZ}			2	4.5	6	2	8.5	2	7	

¶ For conditions shown as MIN or MAX, use the appropriate value specified under recommended operating conditions.

NOTE 3: Load circuits and waveforms are shown in Section 1.

IMPORTANT NOTICE

Texas Instruments and its subsidiaries (TI) reserve the right to make changes to their products or to discontinue any product or service without notice, and advise customers to obtain the latest version of relevant information to verify, before placing orders, that information being relied on is current and complete. All products are sold subject to the terms and conditions of sale supplied at the time of order acknowledgement, including those pertaining to warranty, patent infringement, and limitation of liability.

TI warrants performance of its semiconductor products to the specifications applicable at the time of sale in accordance with TI's standard warranty. Testing and other quality control techniques are utilized to the extent TI deems necessary to support this warranty. Specific testing of all parameters of each device is not necessarily performed, except those mandated by government requirements.

CERTAIN APPLICATIONS USING SEMICONDUCTOR PRODUCTS MAY INVOLVE POTENTIAL RISKS OF DEATH, PERSONAL INJURY, OR SEVERE PROPERTY OR ENVIRONMENTAL DAMAGE ("CRITICAL APPLICATIONS"). TI SEMICONDUCTOR PRODUCTS ARE NOT DESIGNED, AUTHORIZED, OR WARRANTED TO BE SUITABLE FOR USE IN LIFE-SUPPORT DEVICES OR SYSTEMS OR OTHER CRITICAL APPLICATIONS. INCLUSION OF TI PRODUCTS IN SUCH APPLICATIONS IS UNDERSTOOD TO BE FULLY AT THE CUSTOMER'S RISK.

In order to minimize risks associated with the customer's applications, adequate design and operating safeguards must be provided by the customer to minimize inherent or procedural hazards.

TI assumes no liability for applications assistance or customer product design. TI does not warrant or represent that any license, either express or implied, is granted under any patent right, copyright, mask work right, or other intellectual property right of TI covering or relating to any combination, machine, or process in which such semiconductor products or services might be or are used. TI's publication of information regarding any third party's products or services does not constitute TI's approval, warranty or endorsement thereof.