

SYNCHRONOUS 4-BIT UP/DOWN BINARY COUNTER

SDFS089 – MARCH 1987 – REVISED OCTOBER 1993

- Fully Synchronous Operation for Counting and Programming
- Internal Look-Ahead Circuitry for Fast Counting
- Carry Output for N-Bit Cascading
- Fully Independent Clock Circuit
- Package Options Include Plastic Small-Outline Packages and Standard Plastic 300-mil DIPs

D OR N PACKAGE
(TOP VIEW)

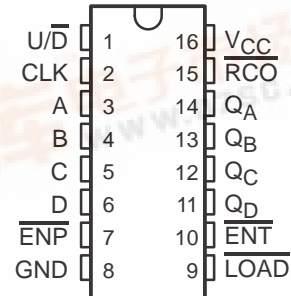

description

This synchronous, presettable, 4-bit up/down binary counter features an internal carry look-ahead circuitry for cascading in high-speed counting applications. Synchronous operation is provided by having all flip-flops clocked simultaneously so that the outputs change coincident with each other when so instructed by the count-enable ($\overline{\text{ENP}}$, $\overline{\text{ENT}}$) inputs and internal gating. This mode of operation eliminates the output counting spikes that are normally associated with asynchronous (ripple-clock) counters. A buffered clock (CLK) input triggers the four flip-flops on the rising (positive-going) edge of the clock waveform.

This counter is fully programmable; that is, it may be preset to any number between 0 and its maximum count. The load-input circuitry allows loading with the carry-enable output of cascaded counters. As loading is synchronous, setting up a low level at the load ($\overline{\text{LOAD}}$) input disables the counter and causes the outputs to agree with the data inputs after the next clock pulse.

The carry look-ahead circuitry provides for cascading counters for n-bit synchronous application without additional gating. Instrumental in accomplishing this function are two count-enable ($\overline{\text{ENP}}$, $\overline{\text{ENT}}$) inputs and a ripple-carry ($\overline{\text{RCO}}$) output. Both $\overline{\text{ENP}}$ and $\overline{\text{ENT}}$ must be low to count. The direction of the count is determined by the level of the up/down ($\text{U}/\overline{\text{D}}$) input. When $\text{U}/\overline{\text{D}}$ is high, the counter counts up; when low, it counts down. Input $\overline{\text{ENT}}$ is fed forward to enable the $\overline{\text{RCO}}$. $\overline{\text{RCO}}$ thus enabled will produce a low-level pulse while the count is zero (all inputs low) counting down or maximum (9 or 15) counting up. This low-level overflow ripple-carry pulse can be used to enable successive cascaded stages. Transitions at $\overline{\text{ENP}}$ or $\overline{\text{ENT}}$ are allowed regardless of the level of the clock input. All inputs are diode clamped to minimize transmission-line effects, thereby simplifying system design.

The SN74F169 features a fully independent clock circuit. Changes at control inputs ($\overline{\text{ENP}}$, $\overline{\text{ENT}}$, $\overline{\text{LOAD}}$ or $\text{U}/\overline{\text{D}}$) that will modify the operating mode have no effect on the contents of the counter until clocking occurs. The function of the counter (whether enabled, disabled, loading, or counting) will be dictated solely by the conditions meeting the setup and hold times.

The SN74F169 is characterized for operation from 0°C to 70°C.



SN74F169 SYNCHRONOUS 4-BIT UP/DOWN BINARY COUNTER

SDFS089 – MARCH 1987 – REVISED OCTOBER 1993

logic symbol†

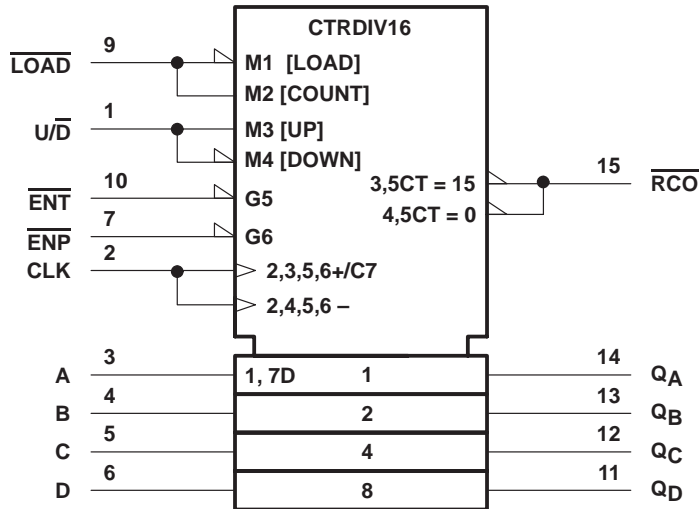

† This symbol is in accordance with ANSI/IEEE Std 91-1984 and IEC Publication 617-12.

SN74F169 SYNCHRONOUS 4-BIT UP/DOWN BINARY COUNTER

SDFS089 – MARCH 1987 – REVISED OCTOBER 1993

logic diagram (positive logic)

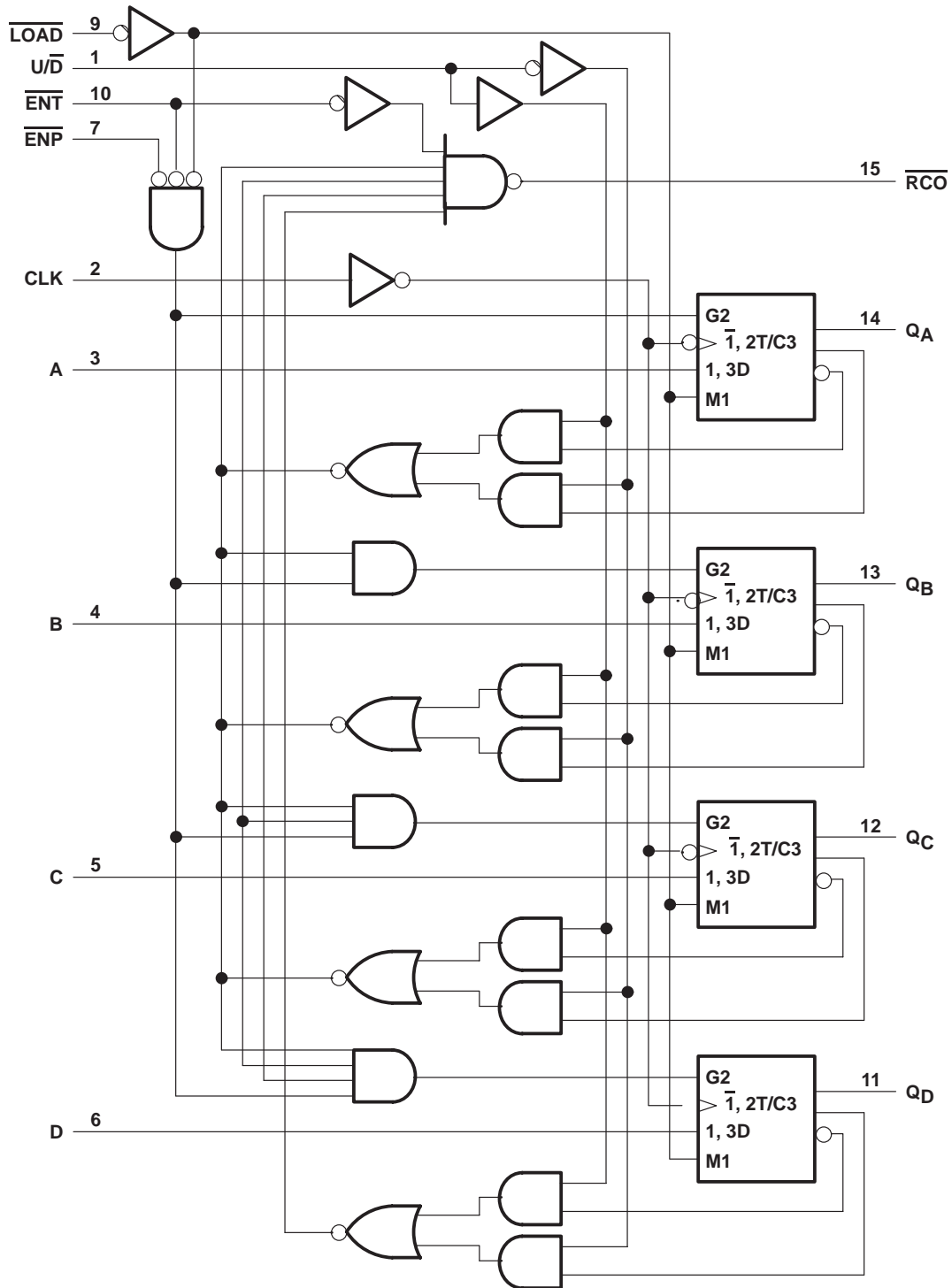

SN74F169 SYNCHRONOUS 4-BIT UP/DOWN BINARY COUNTER

SDFS089 – MARCH 1987 – REVISED OCTOBER 1993

logic symbol, each flip-flop

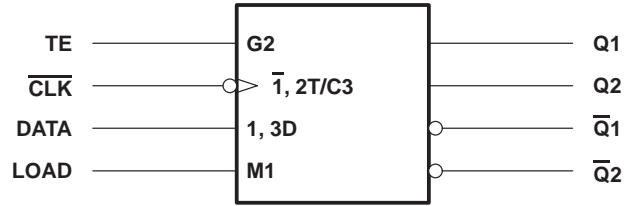

logic diagram, each flip-flop (positive logic)

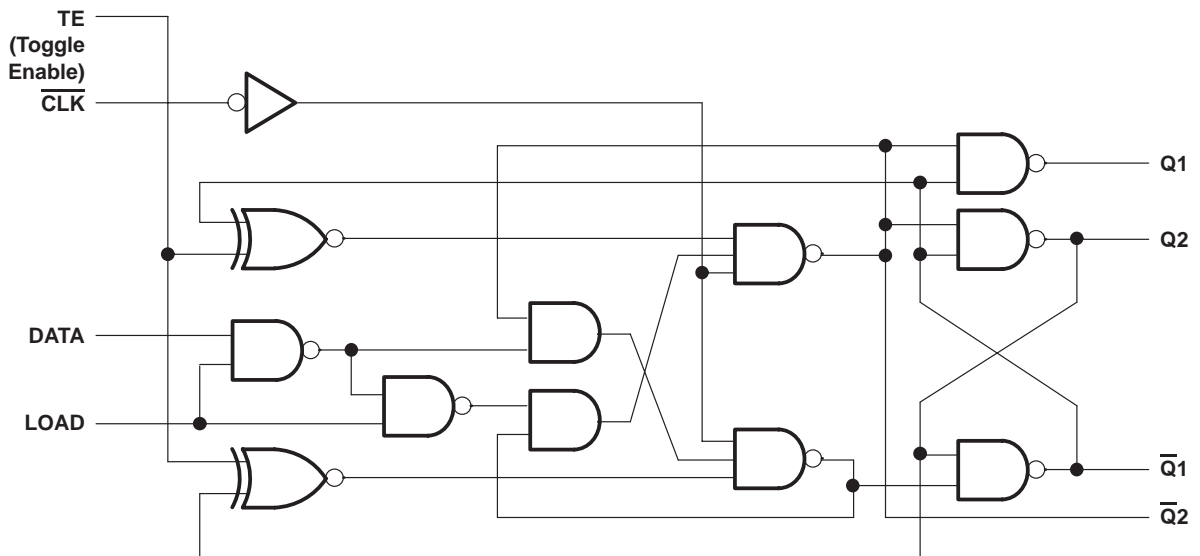

FUNCTION TABLE
(each flip-flop)

COUNTER INPUTS		FLIP-FLOP INPUTS				OUTPUTS	
LOAD	CLK	LOAD	TE	CLK	DATA	Q	Q̄
L	↑	H	L	↓	H	H	L
L	↑	H	L	↓	L	L	H
H	↑	L	H	↓	X	Q̄ ₀	Q ₀
H	↑	L	L	↓	X	Q ₀	Q̄ ₀

SN74F169 SYNCHRONOUS 4-BIT UP/DOWN BINARY COUNTER

SDFS089 – MARCH 1987 – REVISED OCTOBER 1993

typical load, count, and inhibit sequences

Illustrated below is the following sequence:

1. Load (preset) to binary thirteen
2. Count up to fourteen, fifteen (maximum), zero, one, and two
3. Inhibit
4. Count down to one, zero (minimum), fifteen, fourteen, and thirteen

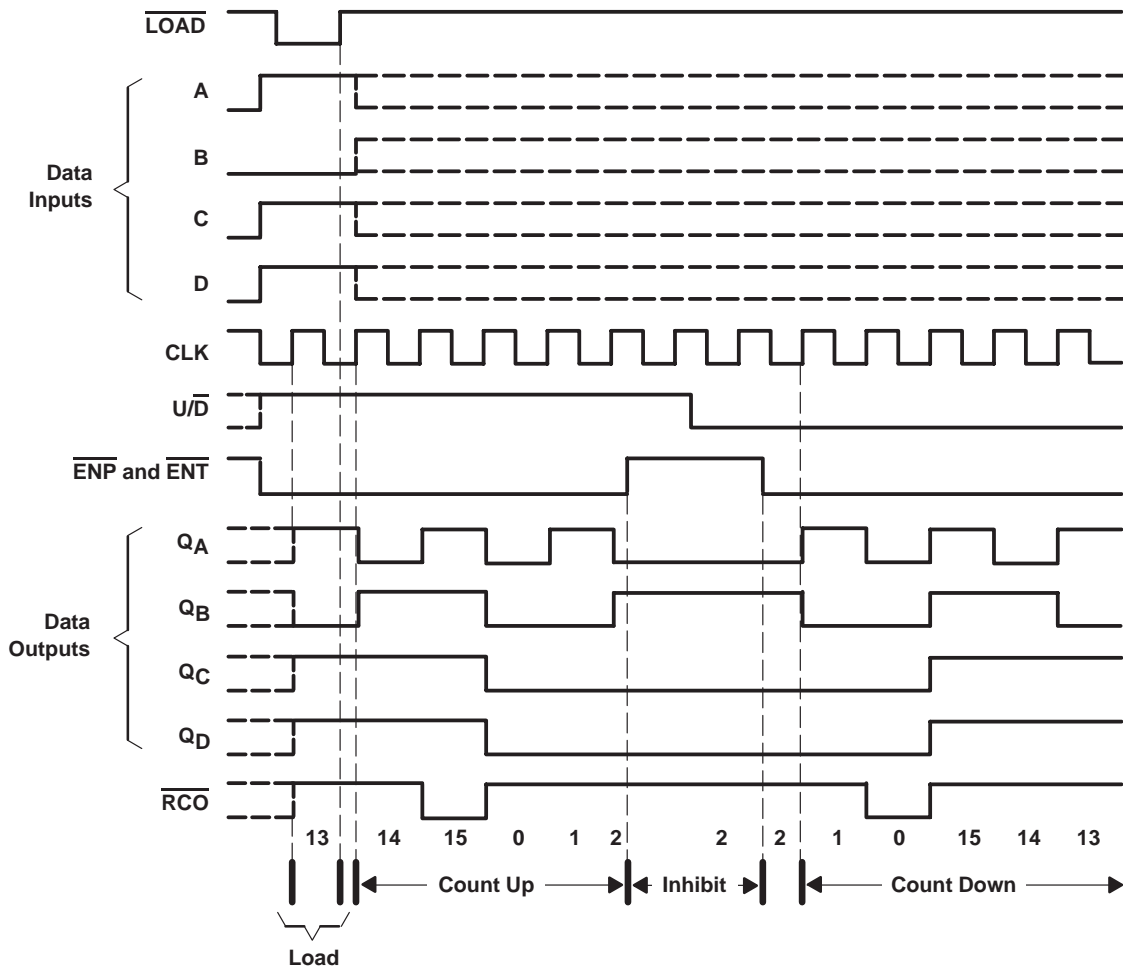

SN74F169

SYNCHRONOUS 4-BIT UP/DOWN BINARY COUNTER

SDFS089 – MARCH 1987 – REVISED OCTOBER 1993

absolute maximum ratings over operating free-air temperature range (unless otherwise noted)†

Supply voltage range, V_{CC}	–0.5 V to 7 V
Input voltage range, V_I (see Note 1)	–1.2 V to 7 V
Input current range	–30 mA to 5 mA
Voltage range applied to any output in the high state	–0.5 V to V_{CC}
Current into any output in the low state	40 mA
Operating free-air temperature range	0°C to 70°C
Storage temperature range	–65°C to 150°C

† Stresses beyond those listed under “absolute maximum ratings” may cause permanent damage to the device. These are stress ratings only and functional operation of the device at these or any other conditions beyond those indicated under “recommended operating conditions” is not implied. Exposure to absolute-maximum-rated conditions for extended periods may affect device reliability.

NOTE 1: The input voltage ratings may be exceeded provided the input current ratings are observed.

recommended operating conditions

	MIN	NOM	MAX	UNIT
V_{CC} Supply voltage	4.5	5	5.5	V
V_{IH} High-level input voltage	2			V
V_{IL} Low-level input voltage			0.8	V
I_{IK} Input clamp current			–18	mA
I_{OH} High-level output current			–1	mA
I_{OL} Low-level output current			20	mA
T_A Operating free-air temperature	0		70	°C

electrical characteristics over recommended operating free-air temperature range (unless otherwise noted)

PARAMETER	TEST CONDITIONS	MIN	TYP‡	MAX	UNIT
V_{IK}	$V_{CC} = 4.5$ V, $I_I = -18$ mA			–1.2	V
V_{OH}	$V_{CC} = 4.5$ V, $I_{OH} = -1$ mA	2.5	3.4		V
	$V_{CC} = 4.75$ V, $I_{OH} = -1$ mA	2.7			
V_{OL}	$V_{CC} = 4.5$ V, $I_{OL} = 20$ mA		0.3	0.5	V
I_I	$V_{CC} = 5.5$ V, $V_I = 7$ V			0.1	mA
I_{IH}	$V_{CC} = 5.5$ V, $V_I = 2.7$ V			20	µA
I_{IL}	$V_{CC} = 5.5$ V, $V_I = 0.5$ V			–1.2	mA
				–0.6	
$I_{OS}§$	$V_{CC} = 5.5$ V, $V_O = 0$	–60		–150	mA
I_{CC}	$V_{CC} = 5.5$ V, See Note 2		38	52	mA

‡ All typical values are at $V_{CC} = 5$ V, $T_A = 25^\circ\text{C}$.

§ Not more than one output should be shorted at a time, and the duration of the short circuit should not exceed one second.

NOTE 2: I_{CC} is measured after applying a momentary 4.5 V, then ground, to the clock input with B and ENT inputs high and all other inputs low.

SN74F169

SYNCHRONOUS 4-BIT UP/DOWN BINARY COUNTER

SDFS089 – MARCH 1987 – REVISED OCTOBER 1993

timing requirements over recommended ranges of supply voltage and operating free-air temperature (unless otherwise noted)

			$V_{CC} = 5\text{ V},$ $T_A = 25^\circ\text{C}$		MIN	MAX	UNIT
			MIN	MAX			
f_{clock}	Clock frequency		0	100	0	90	MHz
t_w	Pulse duration	CLK high or low	5		5.5		ns
t_{su}	Setup time	Data before CLK \uparrow	High or low	4	4.5	ns	
		$\overline{\text{LOAD}}$ before CLK \uparrow	High or low	8	9		
		$\overline{\text{ENP}}$ and $\overline{\text{ENT}}$ before CLK \uparrow	High or low	5	6		
		U/\overline{D} before CLK \uparrow	High	11	12.5		
t_h	Hold time	U/\overline{D} before CLK \uparrow	Low	7	8	ns	
		Data after CLK \uparrow	High or low	3	3.5		
		$\overline{\text{LOAD}}$ after CLK \uparrow	High or low	0	0		
		$\overline{\text{ENP}}$ and $\overline{\text{ENT}}$ after CLK \uparrow	High or low	0	0		
		U/\overline{D} after CLK \uparrow	High or low	0	0		

switching characteristics (see Note 3)

PARAMETER	FROM (INPUT)	TO (OUTPUT)	$V_{CC} = 5\text{ V},$ $C_L = 50\text{ pF},$ $R_L = 500\ \Omega,$ $T_A = 25^\circ\text{C}$			$V_{CC} = 4.5\text{ V to }5.5\text{ V},$ $C_L = 50\text{ pF},$ $R_L = 500\ \Omega,$ $T_A = \text{MIN to MAX}^\dagger$		UNIT
			MIN	TYP	MAX	MIN	MAX	
f_{max}			100	115		90		MHz
t_{PLH}	CLK	Q	2.2	6.1	8.5	2.2	9.5	ns
t_{PHL}			3.2	8.6	11.5	3.2	13	
t_{PLH}	CLK	$\overline{\text{RCO}}$	4.7	11.6	15.5	4.7	17	ns
t_{PHL}			3.2	8.1	11	3.2	12.5	
t_{PLH}	$\overline{\text{ENT}}$	$\overline{\text{RCO}}$	1.7	4.1	6	1.7	7	ns
t_{PHL}			1.7	5.6	8	1.7	9	
t_{PLH}	U/\overline{D}	$\overline{\text{RCO}}$	2.7	8.1	11	2.7	12.5	ns
t_{PHL}			3.2	7.6	10.5	3.2	12	

† For conditions shown as MIN or MAX, use the appropriate value specified under recommended operating conditions.

NOTE 3: Load circuits and waveforms are shown in Section 1.

IMPORTANT NOTICE

Texas Instruments and its subsidiaries (TI) reserve the right to make changes to their products or to discontinue any product or service without notice, and advise customers to obtain the latest version of relevant information to verify, before placing orders, that information being relied on is current and complete. All products are sold subject to the terms and conditions of sale supplied at the time of order acknowledgement, including those pertaining to warranty, patent infringement, and limitation of liability.

TI warrants performance of its semiconductor products to the specifications applicable at the time of sale in accordance with TI's standard warranty. Testing and other quality control techniques are utilized to the extent TI deems necessary to support this warranty. Specific testing of all parameters of each device is not necessarily performed, except those mandated by government requirements.

CERTAIN APPLICATIONS USING SEMICONDUCTOR PRODUCTS MAY INVOLVE POTENTIAL RISKS OF DEATH, PERSONAL INJURY, OR SEVERE PROPERTY OR ENVIRONMENTAL DAMAGE ("CRITICAL APPLICATIONS"). TI SEMICONDUCTOR PRODUCTS ARE NOT DESIGNED, AUTHORIZED, OR WARRANTED TO BE SUITABLE FOR USE IN LIFE-SUPPORT DEVICES OR SYSTEMS OR OTHER CRITICAL APPLICATIONS. INCLUSION OF TI PRODUCTS IN SUCH APPLICATIONS IS UNDERSTOOD TO BE FULLY AT THE CUSTOMER'S RISK.

In order to minimize risks associated with the customer's applications, adequate design and operating safeguards must be provided by the customer to minimize inherent or procedural hazards.

TI assumes no liability for applications assistance or customer product design. TI does not warrant or represent that any license, either express or implied, is granted under any patent right, copyright, mask work right, or other intellectual property right of TI covering or relating to any combination, machine, or process in which such semiconductor products or services might be or are used. TI's publication of information regarding any third party's products or services does not constitute TI's approval, warranty or endorsement thereof.