

QUAD MICROPOWER LinCMOS™ VOLTAGE COMPARATORS

SLCS117A – NOVEMBER 1986 – REVISED OCTOBER 1996

- **Push-Pull CMOS Output Drives Capacitive Loads Without Pullup Resistor, $I_O = \pm 8 \text{ mA}$**
- **Very Low Power . . . 200 μW Typ at 5 V**
- **Fast Response Time . . . $t_{PLH} = 2.7 \mu\text{s}$ Typ With 5-mV Overdrive**
- **Single Supply Operation . . . 3 V to 16 V
TLC3704M . . . 4 V to 16 V**
- **On-Chip ESD Protection**

description

The TLC3704 consists of four independent micropower voltage comparators designed to operate from a single supply and be compatible with modern HCMOS logic systems. They are functionally similar to the LM339 but use 1/20th the power for similar response times. The push-pull CMOS output stage drives capacitive loads directly without a power-consuming pullup resistor to achieve the stated response time. Eliminating the pullup resistor not only reduces power dissipation, but also saves board space and component cost. The output stage is also fully compatible with TTL requirements.

Texas Instruments LinCMOS™ process offers superior analog performance to standard CMOS processes. Along with the standard CMOS advantages of low power without sacrificing speed, high input impedance, and low bias currents, the LinCMOS process offers extremely stable input offset voltages with large differential input voltages. This characteristic makes it possible to build reliable CMOS comparators.

The TLC3704C is characterized for operation over the commercial temperature range of 0°C to 70°C. The TLC3704I is characterized for operation over the extended industrial temperature range of -40°C to 85°C. The TLC3704M is characterized for operation over the full military temperature range of -55°C to 125°C. The TLC3704Q is characterized for operation from -40°C to 125°C.

D, J, OR N PACKAGE
(TOP VIEW)

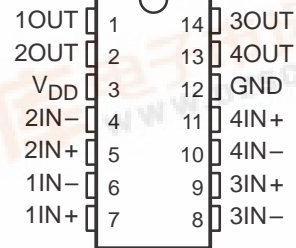

FK PACKAGE
(TOP VIEW)

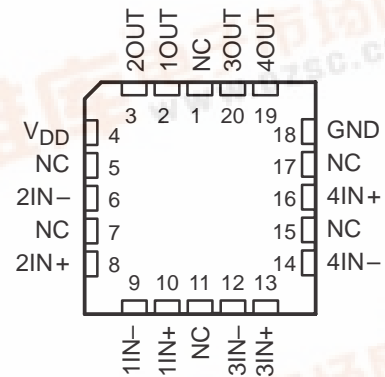

NC – No internal connection

symbol (each comparator)

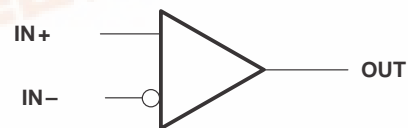

Please be aware that an important notice concerning availability, standard warranty, and use in critical applications of Texas Instruments semiconductor products and disclaimers thereto appears at the end of this data sheet.

LinCMOS is a trademark of Texas Instruments Incorporated.

PRODUCTION DATA information is current as of publication date. Products conform to specifications per the terms of Texas Instruments standard warranty. Production processing does not necessarily include testing of all parameters.

TLC3704, TLC3704Q QUAD MICROPOWER LinCMOS™ VOLTAGE COMPARATORS

SLCS117A – NOVEMBER 1986 – REVISED OCTOBER 1996

AVAILABLE OPTIONS

T _A	V _{IO} max at 25°C	PACKAGE			
		SMALL OUTLINE (D)	CERAMIC (FK)	CERAMIC DIP (J)	PLASTIC DIP (N)
0°C to 70°C	5 mV	TLC3704CD	—	—	TLC3704CN
– 40°C to 85°C	5 mV	TLC3704ID	—	—	TLC3704IN
– 55°C to 125°C	5 mV	—	TLC3704MFK	TLC3704MJ	—
– 40°C to 125°C	5 mV	—	—	TLC3704QJ	—

The D package is available taped and reeled. Add R suffix to the device type (e.g., TLC3704CDR).

functional block diagram (each comparator)

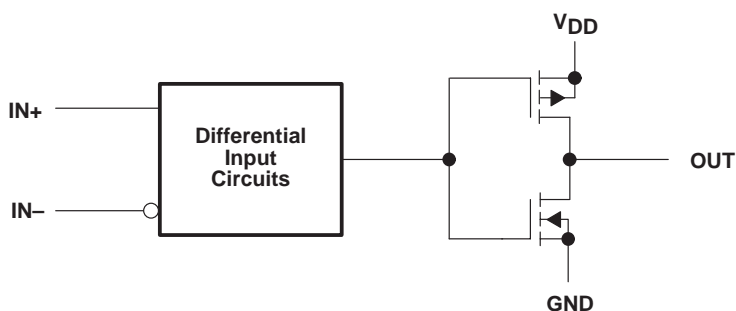

absolute maximum ratings over operating free-air temperature range (unless otherwise noted)†

Supply voltage range, V _{DD} (see Note 1)	– 0.3 V to 18 V
Differential input voltage, V _{ID} (see Note 2)	± 18 V
Input voltage range, V _I	– 0.3 to V _{DD}
Output voltage range, V _O	– 0.3 to V _{DD}
Input current, I _I	± 5 mA
Output current, I _O (each output)	± 20 mA
Total supply current into V _{DD}	40 mA
Total current out of GND	60 mA
Continuous total power dissipation	See Dissipation Rating Table
Operating free-air temperature range, T _A : TLC3704C	0 to 70°C
TLC3704I	– 40°C to 85°C
TLC3704M	– 55°C to 125°C
TLC3704Q	– 40°C to 125°C
Storage temperature range	– 65°C to 150°C
Case temperature for 60 seconds: FK package	260°C
Lead temperature 1,6 mm (1/16 inch) from case for 10 seconds: D or N package	260°C
Lead temperature 1,6 mm (1/16 inch) from case for 60 seconds: J package	300°C

† Stresses beyond those listed under “absolute maximum ratings” may cause permanent damage to the device. These are stress ratings only, and functional operation of the device at these or any other conditions beyond those indicated under “recommended operating conditions” is not implied. Exposure to absolute-maximum-rated conditions for extended periods may affect device reliability.

- NOTES: 1. All voltage values, except differential voltages, are with respect to network ground.
2. Differential voltages are at IN+ with respect to IN–.

TLC3704, TLC3704Q

QUAD MICROPOWER LinCMOS™ VOLTAGE COMPARATORS

SLCS117A – NOVEMBER 1986 – REVISED OCTOBER 1996

DISSIPATION RATING TABLE

PACKAGE	$T_A \leq 25^\circ\text{C}$	DERATING FACTOR	$T_A = 70^\circ\text{C}$	$T_A = 85^\circ\text{C}$	$T_A = 125^\circ\text{C}$
	POWER RATING	ABOVE $T_A = 25^\circ\text{C}$	POWER RATING	POWER RATING	POWER RATING
D	950 mW	7.6 mW/°C	608 mW	494 mW	N/A
FK	1375 mW	11.0 mW/°C	880 mW	715 mW	275 mW
J	1375 mW	11.0 mW/°C	880 mW	715 mW	275 mW
N	1150 mW	9.2 mW/°C	736 mW	598 mW	N/A

recommended operating conditions

	TLC3704C			UNIT
	MIN	NOM	MAX	
Supply voltage, V_{DD}	3	5	16	V
Common-mode input voltage, V_{IC}	-0.2	$V_{DD} - 1.5$		V
High-level output current, I_{OH}	-20			mA
Low-level output current, I_{OL}	20			mA
Operating free-air temperature, T_A	0	70		°C

electrical characteristics at specified operating free-air temperature, $V_{DD} = 5\text{ V}$ (unless otherwise noted)

PARAMETER	TEST CONDITIONS†	T_A	TLC3704C			UNIT
			MIN	TYP	MAX	
V_{IO} Input offset voltage	$V_{DD} = 5\text{ V to }10\text{ V}$, $V_{IC} = V_{ICRmin}$, See Note 3	25°C	1.2		5	mV
		0°C to 70°C	6.5			
I_{IO} Input offset current	$V_{IC} = 2.5\text{ V}$	25°C	1			pA
		70°C			0.3	nA
I_{IB} Input bias current	$V_{IC} = 2.5\text{ V}$	25°C	5			pA
		70°C			0.6	nA
V_{ICR} Common-mode input voltage range		25°C	0 to $V_{DD} - 1$			V
		0°C to 70°C	0 to $V_{DD} - 1.5$			
CMRR Common-mode rejection ratio	$V_{IC} = V_{ICRmin}$	25°C	84			dB
		70°C	84			
		0°C	84			
k_{SVR} Supply-voltage rejection ratio	$V_{DD} = 5\text{ V to }10\text{ V}$	25°C	85			dB
		70°C	85			
		0°C	85			
V_{OH} High-level output voltage	$V_{ID} = 1\text{ V}$, $I_{OH} = -4\text{ mA}$	25°C	4.5	4.7		V
		70°C	4.3			
V_{OL} Low-level output voltage	$V_{ID} = -1\text{ V}$, $I_{OH} = 4\text{ mA}$	25°C	210		300	mV
		70°C	375			
I_{DD} Supply current (all four comparators)	Outputs low, No load	25°C	35		80	µA
		0°C to 70°C	100			

† All characteristics are measured with zero common-mode voltage unless otherwise noted.

NOTE 3: The offset voltage limits given are the maximum values required to drive the output up to 4.5 V or down to 0.3 V.

TLC3704, TLC3704Q

QUAD MICROPOWER LinCMOS™ VOLTAGE COMPARATORS

SLCS117A – NOVEMBER 1986 – REVISED OCTOBER 1996

recommended operating conditions

	TLC3704I			UNIT
	MIN	NOM	MAX	
Supply voltage, V_{DD}	3	5	16	V
Common-mode input voltage, V_{IC}	-0.2		$V_{DD} - 1.5$	V
High-level output current, I_{OH}			-20	mA
Low-level output current, I_{OL}			20	mA
Operating free-air temperature, T_A	-40		85	°C

electrical characteristics at specified operating free-air temperature, $V_{DD} = 5\text{ V}$, $V_{IC} = 0$ (unless otherwise noted)

PARAMETER	TEST CONDITIONS	T_A	TLC3704I			UNIT
			MIN	TYP	MAX	
V_{IO} Input offset voltage	$V_{DD} = 5\text{ V to } 10\text{ V}$, $V_{IC} = V_{ICRmin}$, See Note 3	25°C		1.2	5	mV
		-40°C to 85°C			7	
I_{IO} Input offset current	$V_{IC} = 2.5\text{ V}$	25°C		1		pA
		85°C			1	nA
I_{IB} Input bias current	$V_{IC} = 2.5\text{ V}$	25°C		5		pA
		85°C			2	nA
V_{ICR} Common-mode input voltage range		25°C		0 to $V_{DD} - 1$		V
		-40°C to 85°C		0 to $V_{DD} - 1.5$		
CMRR Common-mode rejection ratio	$V_{IC} = V_{ICRmin}$	25°C		84		dB
		85°C		84		
		-40°C		83		
k_{SVR} Supply-voltage rejection ratio	$V_{DD} = 5\text{ V to } 10\text{ V}$	25°C		85		dB
		85°C		85		
		-40°C		83		
V_{OH} High-level output voltage	$V_{ID} = 1\text{ V}$, $I_{OH} = -4\text{ mA}$	25°C	4.5	4.7		V
		85°C	4.3			
V_{OL} Low-level output voltage	$V_{ID} = -1\text{ V}$, $I_{OH} = 4\text{ mA}$	25°C		210	300	mV
		85°C			400	
I_{DD} Supply current (all four comparators)	Outputs low, No load	25°C		35	80	μA
		-40°C to 85°C			125	

NOTE 3: The offset voltage limits given are the maximum values required to drive the output up to 4.5 V or down to 0.3 V.

TLC3704, TLC3704Q

QUAD MICROPOWER LinCMOS™ VOLTAGE COMPARATORS

SLCS117A – NOVEMBER 1986 – REVISED OCTOBER 1996

recommended operating conditions

	TLC3704M			UNIT
	MIN	NOM	MAX	
Supply voltage, V_{DD}	4	5	16	V
Common-mode input voltage, V_{IC}	0	$V_{DD} - 1.5$		V
High-level output current, I_{OH}	– 20			mA
Low-level output current, I_{OL}	20			mA
Operating free-air temperature, T_A	– 55	125		°C

electrical characteristics at specified operating free-air temperature, $V_{DD} = 5$ V, $V_{IC} = 0$ (unless otherwise noted)

PARAMETER	TEST CONDITIONS	T_A	TLC3704M			UNIT
			MIN	TYP	MAX	
V_{IO} Input offset voltage	$V_{DD} = 5$ V to 10 V, $V_{IC} = V_{ICRmin}$, See Note 3	25°C	1.2		5	mV
		–55°C to 125°C			10	
I_{IO} Input offset current	$V_{IC} = 2.5$ V	25°C	1			pA
		125°C			15	nA
I_{IB} Input bias current	$V_{IC} = 2.5$ V	25°C	5			pA
		125°C			30	nA
V_{ICR} Common-mode input voltage range		25°C	0 to $V_{DD} - 1$			V
		–55°C to 125°C	0 to $V_{DD} - 1.5$			
CMRR Common-mode rejection ratio	$V_{IC} = V_{ICRmin}$	25°C	84			dB
		125°C	83			
		–55°C	82			
k_{SVR} Supply-voltage rejection ratio	$V_{DD} = 5$ V to 10 V	25°C	85			dB
		125°C	85			
		–55°C	82			
V_{OH} High-level output voltage	$V_{ID} = 1$ V, $I_{OH} = -4$ mA	25°C	4.5	4.7		V
		125°C	4.2			
V_{OL} Low-level output voltage	$V_{ID} = -1$ V, $I_{OH} = 4$ mA	25°C	210		300	mV
		125°C			500	
I_{DD} Supply current (all four comparators)	Outputs low, No load	25°C	35		80	μA
		–55°C to 125°C			175	

NOTE 3: The offset voltage limits given are the maximum values required to drive the output up to 4.5 V or down to 0.3 V.

TLC3704, TLC3704Q

QUAD MICROPOWER LinCMOS™ VOLTAGE COMPARATORS

SLCS117A – NOVEMBER 1986 – REVISED OCTOBER 1996

recommended operating conditions

	TLC3704Q			UNIT
	MIN	NOM	MAX	
Supply voltage, V_{DD}	3	5	16	V
Common-mode input voltage, V_{IC}	-0.2		$V_{DD} - 1.5$	V
High-level output current, I_{OH}			-20	mA
Low-level output current, I_{OL}			20	mA
Operating free-air temperature, T_A	-40		125	°C

electrical characteristics at specified operating free-air temperature, $V_{DD} = 5\text{ V}$, $V_{IC} = 0$ (unless otherwise noted)

PARAMETER	TEST CONDITIONS	T_A	TLC3704Q			UNIT
			MIN	TYP	MAX	
V_{IO} Input offset voltage	$V_{DD} = 5\text{ V to }10\text{ V}$, $V_{IC} = V_{ICRmin}$, See Note 3	25°C		1.2	5	mV
		-40°C to 125°C			7	
I_{IO} Input offset current	$V_{IC} = 2.5\text{ V}$	25°C		1		pA
		125°C			15	nA
I_{IB} Input bias current	$V_{IC} = 2.5\text{ V}$	25°C		5		pA
		125°C			30	nA
V_{ICR} Common-mode input voltage range		25°C	0 to $V_{DD} - 1$			V
		-40°C to 125°C	0 to $V_{DD} - 1.5$			
CMRR Common-mode rejection ratio	$V_{IC} = V_{ICRmin}$	25°C	84			dB
		125°C	83			
		-40°C	83			
k_{SVR} Supply-voltage rejection ratio	$V_{DD} = 5\text{ V to }10\text{ V}$	25°C	85			dB
		125°C	85			
		-40°C	83			
V_{OH} High-level output voltage	$V_{ID} = 1\text{ V}$, $I_{OH} = -4\text{ mA}$	25°C	4.5	4.7		V
		125°C	4.2			
V_{OL} Low-level output voltage	$V_{ID} = -1\text{ V}$, $I_{OH} = 4\text{ mA}$	25°C	210		300	mV
		125°C	500			
I_{DD} Supply current (all four comparators)	Outputs low, No load	25°C	35		80	μA
		-40°C to 125°C	175			

NOTE 3: The offset voltage limits given are the maximum values required to drive the output up to 4.5 V or down to 0.3 V.

TLC3704, TLC3704Q

QUAD MICROPOWER LinCMOS™ VOLTAGE COMPARATORS

SLCS117A – NOVEMBER 1986 – REVISED OCTOBER 1996

switching characteristics, $V_{DD} = 5\text{ V}$, $T_A = 25^\circ\text{C}$

PARAMETER		TEST CONDITIONS		TLC3704C, TLC3704I TLC3704M, TLC3704Q			UNIT
				MIN	TYP	MAX	
t _{PLH}	Propagation delay time, low-to-high-level output†	f = 10 kHz, C _L = 50 pF	Overdrive = 2 mV	4.5		μs	
			Overdrive = 5 mV	2.7			
			Overdrive = 10 mV	1.9			
			Overdrive = 20 mV	1.4			
			Overdrive = 40 mV	1.1			
V _I = 1.4-V step at IN+			1.1				
t _{PHL}	Propagation delay time, high-to-low-level output†	f = 10 kHz, C _L = 50 pF	Overdrive = 2 mV	4		μs	
			Overdrive = 5 mV	2.3			
			Overdrive = 10 mV	1.5			
			Overdrive = 20 mV	0.95			
			Overdrive = 40 mV	0.65			
V _I = 1.4-V step at IN+			0.15				
t _f	Fall time	f = 10 kHz, C _L = 50 pF	Overdrive = 50 mV	50		ns	
t _r	Rise time	f = 10 kHz, C _L = 50 pF	Overdrive = 50 mV	125		ns	

† Simultaneous switching of inputs causes degradation in output response.

TLC3704, TLC3704Q QUAD MICROPOWER LinCMOS™ VOLTAGE COMPARATORS

SLCS117A – NOVEMBER 1986 – REVISED OCTOBER 1996

PRINCIPLES OF OPERATION

LinCMOS process

The LinCMOS process is a linear polysilicon-gate CMOS process. Primarily designed for single-supply applications, LinCMOS products facilitate the design of a wide range of high-performance analog functions from operational amplifiers to complex mixed-mode converters.

While digital designers are experienced with CMOS, MOS technologies are relatively new for analog designers. This short guide is intended to answer the most frequently asked questions related to the quality and reliability of LinCMOS products. Further questions should be directed to the nearest TI field sales office.

electrostatic discharge

CMOS circuits are prone to gate oxide breakdown when exposed to high voltages even if the exposure is only for very short periods of time. Electrostatic discharge (ESD) is one of the most common causes of damage to CMOS devices. It can occur when a device is handled without proper consideration for environmental electrostatic charges, e.g., during board assembly. If a circuit in which one amplifier from a dual op amp is being used and the unused pins are left open, high voltages tends to develop. If there is no provision for ESD protection, these voltages may eventually punch through the gate oxide and cause the device to fail. To prevent voltage buildup, each pin is protected by internal circuitry.

Standard ESD-protection circuits safely shunt the ESD current by providing a mechanism whereby one or more transistors break down at voltages higher than the normal operating voltages but lower than the breakdown voltage of the input gate. This type of protection scheme is limited by leakage currents which flow through the shunting transistors during normal operation after an ESD voltage has occurred. Although these currents are small, on the order of tens of nanoamps, CMOS amplifiers are often specified to draw input currents as low as tens of picoamps.

To overcome this limitation, TI design engineers developed the patented ESD-protection circuit shown in Figure 1. This circuit can withstand several successive 2-kV ESD pulses, while reducing or eliminating leakage currents that may be drawn through the input pins. A more detailed discussion of the operation of the TI ESD-protection circuit is presented on the next page.

All input and output pins on LinCMOS and Advanced LinCMOS products have associated ESD-protection circuitry that undergoes qualification testing to withstand 2000 V discharged from a 100-pF capacitor through a 1500-Ω resistor (human body model) and 200 V from a 100-pF capacitor with no current-limiting resistor (charged device model). These tests simulate both operator and machine handling of devices during normal test and assembly operations.

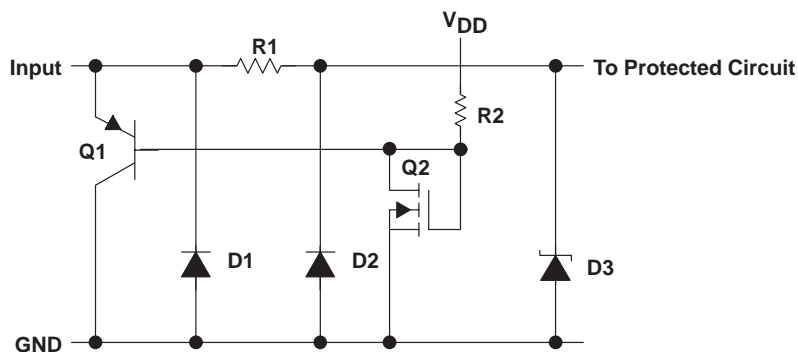

Figure 1. LinCMOS ESD-Protection Schematic

TLC3704, TLC3704Q QUAD MICROPOWER LinCMOS™ VOLTAGE COMPARATORS

SLCS117A – NOVEMBER 1986 – REVISED OCTOBER 1996

PRINCIPLES OF OPERATION

input protection circuit operation

Texas Instruments patented protection circuitry allows for both positive- and negative-going ESD transients. These transients are characterized by extremely fast rise times and usually low energies, and can occur both when the device has all pins open and when it is installed in a circuit.

positive ESD transients

Initial positive charged energy is shunted through Q1 to V_{SS} . Q1 turns on when the voltage at the input rises above the voltage on the V_{DD} pin by a value equal to the V_{BE} of Q1. The base current increases through R2 with input current as Q1 saturates. The base current through R2 forces the voltage at the drain and gate of Q2 to exceed its threshold level ($V_T \sim 22$ to 26 V) and turn Q2 on. The shunted input current through Q1 to V_{SS} is now shunted through the n-channel enhancement-type MOSFET Q2 to V_{SS} . If the voltage on the input pin continues to rise, the breakdown voltage of the zener diode D3 is exceeded and all remaining energy is dissipated in R1 and D3. The breakdown voltage of D3 is designed to be 24 to 27 V, which is well below the gate-oxide voltage of the circuit to be protected.

negative ESD transients

The negative charged ESD transients are shunted directly through D1. Additional energy is dissipated in R1 and D2 as D2 becomes forward biased. The voltage seen by the protected circuit is -0.3 V to -1 V (the forward voltage of D1 and D2).

circuit-design considerations

LinCMOS products are being used in actual circuit environments that have input voltages that exceed the recommended common-mode input voltage range and activate the input protection circuit. Even under normal operation, these conditions occur during circuit power up or power down, and in many cases, when the device is being used for a signal conditioning function. The input voltages can exceed V_{ICR} and not damage the device only if the inputs are current limited. The recommended current limit shown on most product data sheets is ± 5 mA. Figures 2 and 3 show typical characteristics for input voltage versus input current.

Normal operation and correct output state can be expected even when the input voltage exceeds the positive supply voltage. Again, the input current should be externally limited even though internal positive current limiting is achieved in the input protection circuit by the action of Q1. When Q1 is on, it saturates and limit the current to approximately 5-mA collector current by design. When saturated, Q1 base current increases with input current. This base current is forced into the V_{DD} pin and into the device I_{DD} or the V_{DD} supply through R2 producing the current limiting effects shown in Figure 2. This internal limiting lasts only as long as the input voltage is below the V_T of Q2.

When the input voltage exceeds the negative supply voltage, normal operation is affected and output voltage states may not be correct. Also, the isolation between channels of multiple devices (duals and quads) can be severely affected. External current limiting must be used since this current is directly shunted by D1 and D2 and no internal limiting is achieved. If normal output voltage states are required, an external input voltage clamp is required (see Figure 4).

TLC3704, TLC3704Q QUAD MICROPOWER LinCMOS™ VOLTAGE COMPARATORS

SLCS117A – NOVEMBER 1986 – REVISED OCTOBER 1996

PRINCIPLES OF OPERATION

circuit-design considerations (continued)

INPUT CURRENT
vs
INPUT VOLTAGE

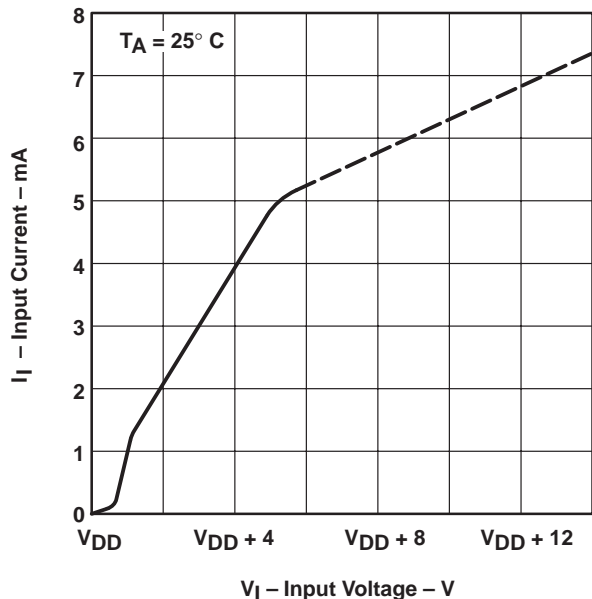

Figure 2

INPUT CURRENT
vs
INPUT VOLTAGE

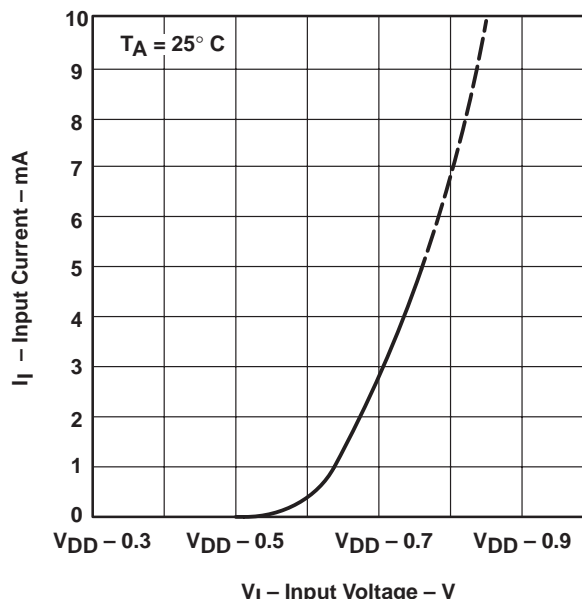
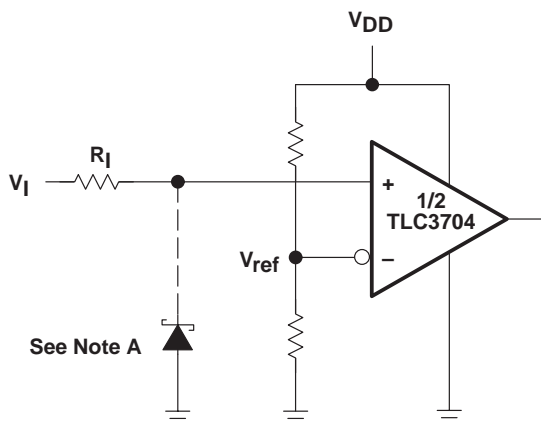

Figure 3



Positive Voltage Input Current Limit :

$$R_I = \frac{V_I - V_{DD} - 0.3 \text{ V}}{5 \text{ mA}}$$

Negative Voltage Input Current Limit :

$$R_I = \frac{-V_I - V_{DD} - (-0.3 \text{ V})}{5 \text{ mA}}$$

NOTE A: If the correct input state is required when the negative input exceeds GND, a Schottky clamp is required.

Figure 4. Typical Input Current-Limiting Configuration for a LinCMOS Comparator

PARAMETER MEASUREMENT INFORMATION

The TLC3704 contains a digital output stage which, if held in the linear region of the transfer curve, can cause damage to the device. Conventional operational amplifier/comparator testing incorporates the use of a servo loop which is designed to force the device output to a level within this linear region. Since the servo-loop method of testing cannot be used, we offer the following alternatives for measuring parameters such as input offset voltage, common-mode rejection, etc.

To verify that the input offset voltage falls within the limits specified, the limit value is applied to the input as shown in Figure 5(a). With the noninverting input positive with respect to the inverting input, the output should be high. With the input polarity reversed, the output should be low.

A similar test can be made to verify the input offset voltage at the common-mode extremes. The supply voltages can be slewed as shown in Figure 5(b) for the V_{ICR} test, rather than changing the input voltages, to provide greater accuracy.

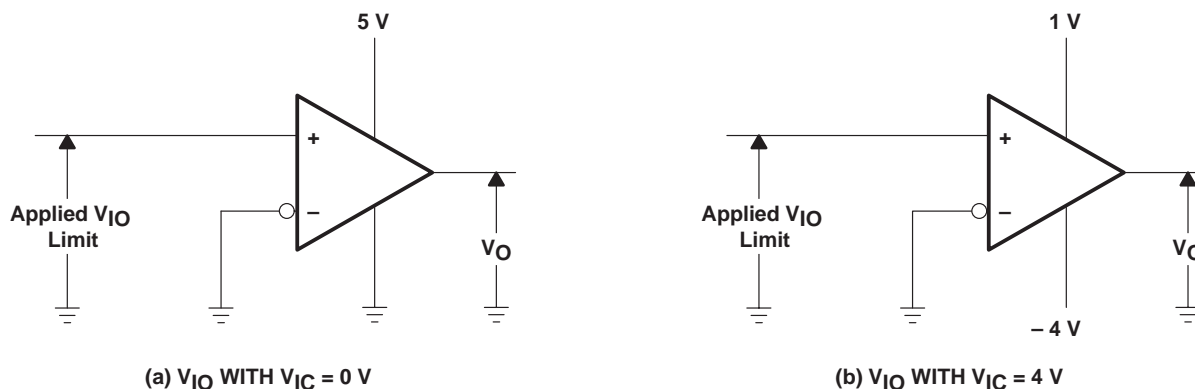

Figure 5. Method for Verifying That Input Offset Voltage Is Within Specified Limits

A close approximation of the input offset voltage can be obtained by using a binary search method to vary the differential input voltage while monitoring the output state. When the applied input voltage differential is equal, but opposite in polarity, to the input offset voltage, the output changes states.

Figure 6 illustrates a practical circuit for direct dc measurement of input offset voltage that does not bias the comparator in the linear region. The circuit consists of a switching mode servo loop in which IC1a generates a triangular waveform of approximately 20-mV amplitude. IC1b acts as a buffer, with C2 and R4 removing any residual d.c. offset. The signal is then applied to the inverting input of the comparator under test, while the noninverting input is driven by the output of the integrator formed by IC1c through the voltage divider formed by R8 and R9. The loop reaches a stable operating point when the output of the comparator under test has a duty cycle of exactly 50%, which can only occur when the incoming triangle wave is sliced symmetrically or when the voltage at the noninverting input exactly equals the input offset voltage.

Voltage divider R8 and R9 provides an increase in the input offset voltage by a factor of 100 to make measurement easier. The values of R5, R7, R8, and R9 can significantly influence the accuracy of the reading; therefore, it is suggested that their tolerance level be one percent or lower.

Measuring the extremely low values of input current requires isolation from all other sources of leakage current and compensation for the leakage of the test socket and board. With a good picoammeter, the socket and board leakage can be measured with no device in the socket. Subsequently, this open socket leakage value can be subtracted from the measurement obtained with a device in the socket to obtain the actual input current of the device.

TLC3704, TLC3704Q QUAD MICROPOWER LinCMOS™ VOLTAGE COMPARATORS

SLCS117A – NOVEMBER 1986 – REVISED OCTOBER 1996

PARAMETER MEASUREMENT INFORMATION

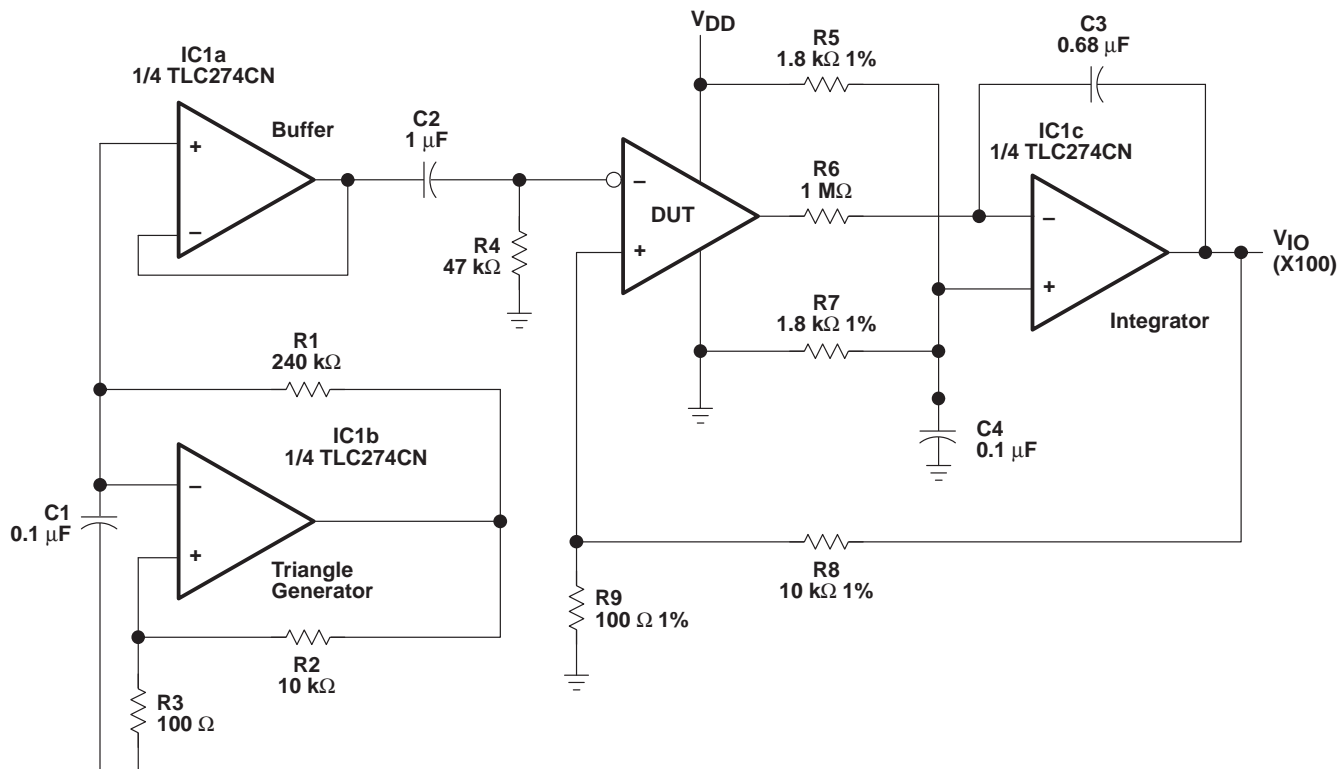

Figure 6. Circuit for Input Offset Voltage Measurement

Response time is defined as the interval between the application of an input step function and the instant when the output reaches 50% of its maximum value. Response time for the low-to-high-level output is measured from the leading edge of the input pulse, while response time for the high-to-low-level output is measured from the trailing edge of the input pulse. Response time measurement at low input signal levels can be greatly affected by the input offset voltage. The offset voltage should be balanced by the adjustment at the inverting input as shown in Figure 7, so that the circuit is just at the transition point. A low signal, for example 105-mV or 5-mV overdrive, causes the output to change state.

TLC3704, TLC3704Q QUAD MICROPOWER LinCMOS™ VOLTAGE COMPARATORS

SLCS117A – NOVEMBER 1986 – REVISED OCTOBER 1996

PARAMETER MEASUREMENT INFORMATION

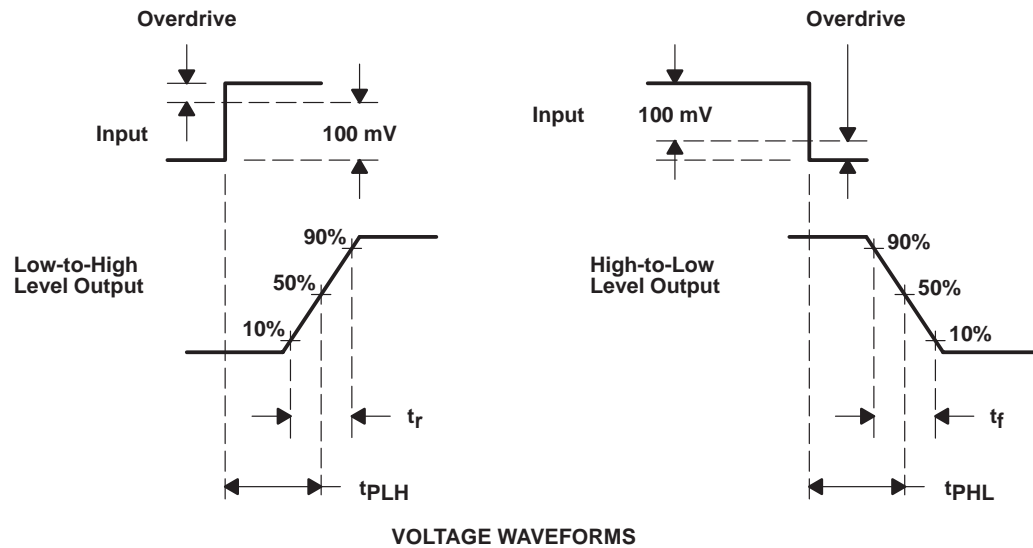
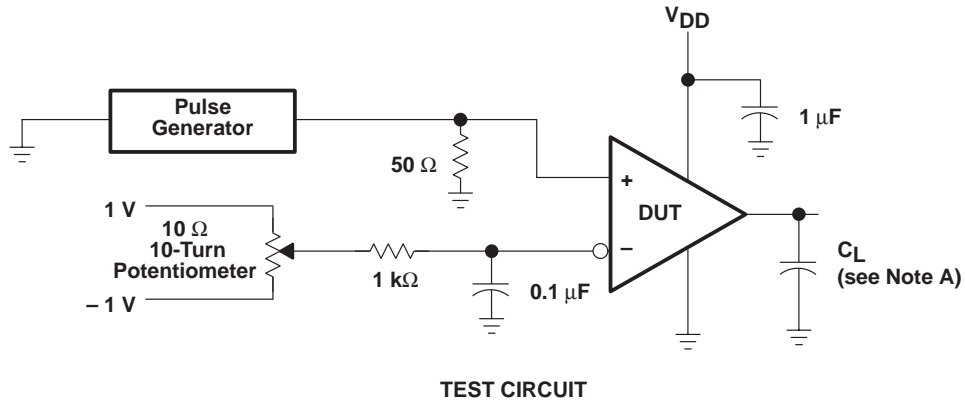

NOTE A: C_L includes probe and jig capacitance.

Figure 7. Response, Rise, and Fall Times Circuit and Voltage Waveforms

TLC3704, TLC3704Q QUAD MICROPOWER LinCMOS™ VOLTAGE COMPARATORS

SLCS117A – NOVEMBER 1986 – REVISED OCTOBER 1996

TYPICAL CHARACTERISTICS

Table of Graphs

		FIGURE	
V_{IO}	Input offset voltage	Distribution	8
I_{IB}	Input bias current	vs Free-air temperature	9
CMRR	Common-mode rejection ratio	vs Free-air temperature	10
k_{SVR}	Supply-voltage rejection ratio	vs Free-air temperature	11
V_{OH}	High-level output current	vs Free-air temperature vs High-level output current	12 13
V_{OL}	Low-level output voltage	vs Low-level output current vs Free-air temperature	14 15
t_t	Transition time	vs Load capacitance	16
	Supply current response	vs Time	17
	Low-to-high-level output response	Low-to-high level output propagation delay time	18
	High-to-low level output response	High-to-low level output propagation delay time	19
t_{PLH}	Low-to-high level output propagation delay time	vs Supply voltage	20
t_{PHL}	High-to-low level output propagation delay time	vs Supply voltage	21
I_{DD}	Supply current	vs Frequency vs Supply voltage vs Free-air temperature	22 23 24

DISTRIBUTION OF INPUT
OFFSET VOLTAGE†

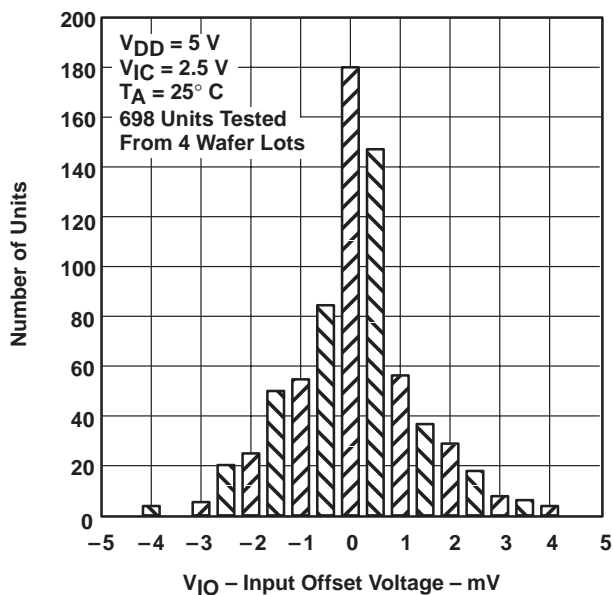

Figure 8

INPUT BIAS CURRENT
vs
FREE-AIR TEMPERATURE†

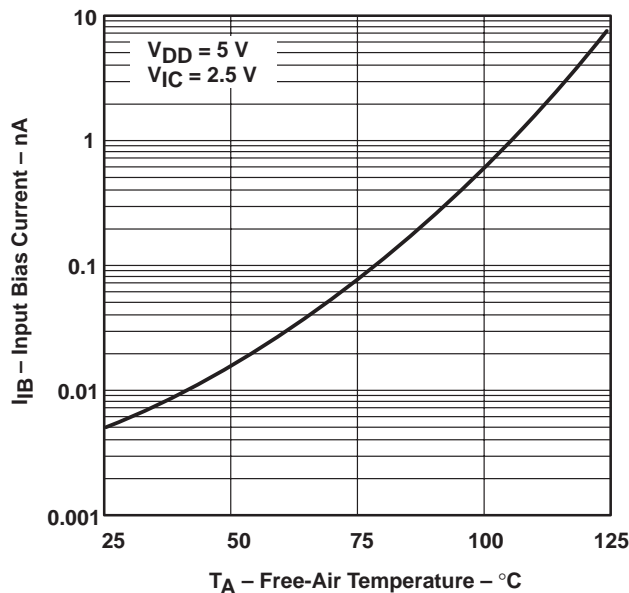

Figure 9

† Data at high and low temperatures are applicable only within the rated operating free-air temperature ranges of the various devices.

TLC3704, TLC3704Q QUAD MICROPOWER LinCMOS™ VOLTAGE COMPARATORS

SLCS117A – NOVEMBER 1986 – REVISED OCTOBER 1996

TYPICAL CHARACTERISTICS†

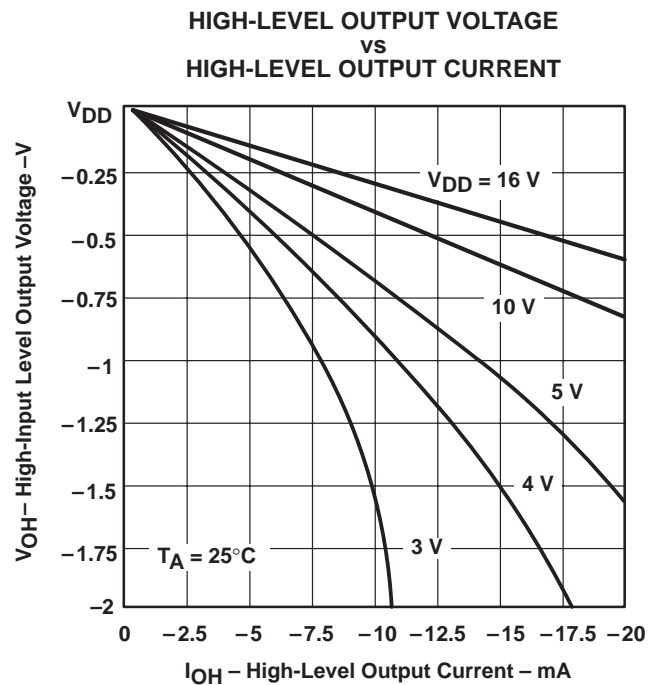
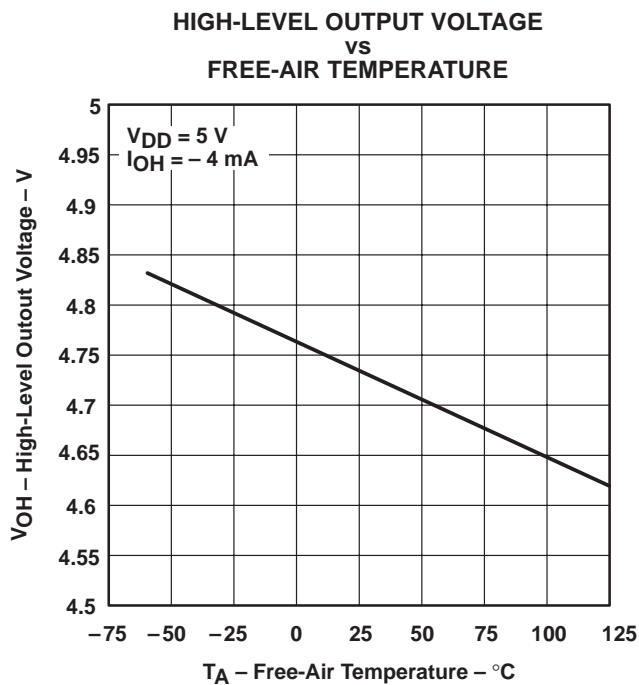
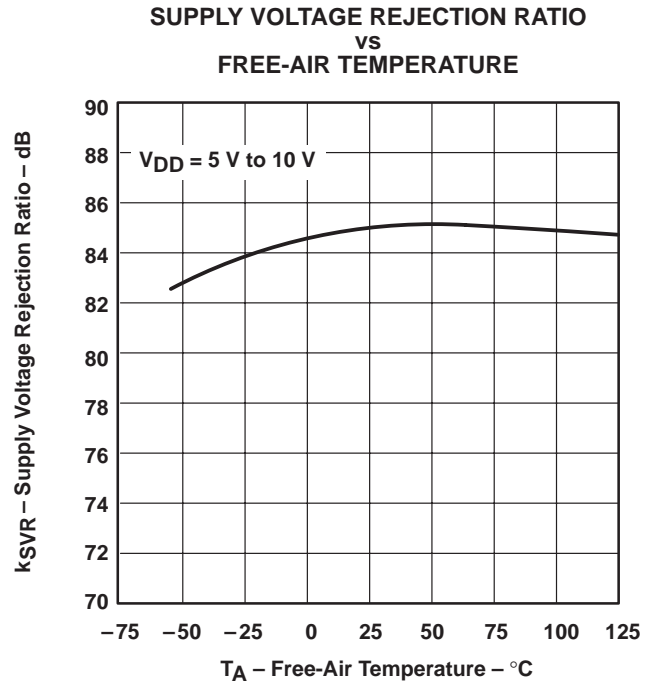
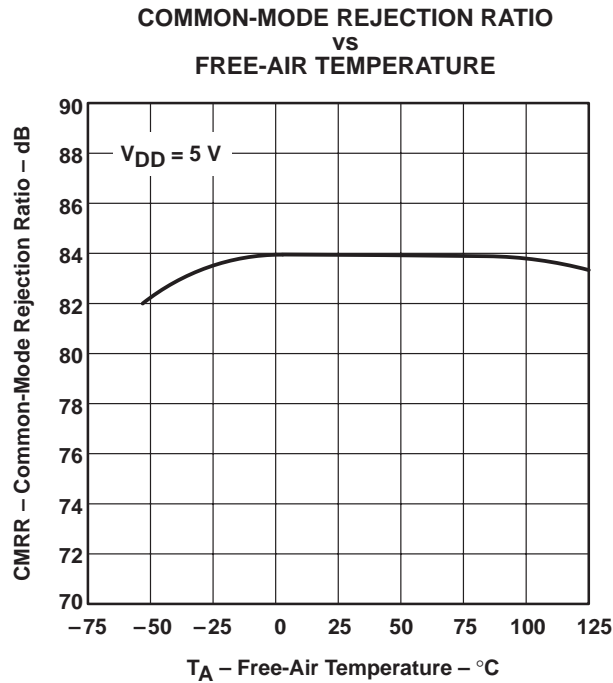

† Data at high and low temperatures are applicable only within the rated operating free-air temperature ranges of the various devices.

TLC3704, TLC3704Q QUAD MICROPOWER LinCMOS™ VOLTAGE COMPARATORS

SLCS117A – NOVEMBER 1986 – REVISED OCTOBER 1996

TYPICAL CHARACTERISTICS†

LOW-LEVEL OUTPUT VOLTAGE
vs
LOW-LEVEL OUTPUT CURRENT

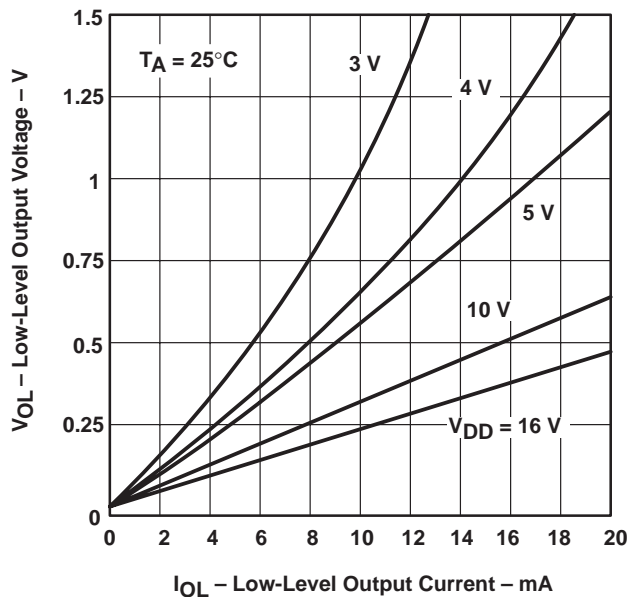

Figure 14

LOW-LEVEL OUTPUT VOLTAGE
vs
FREE-AIR TEMPERATURE

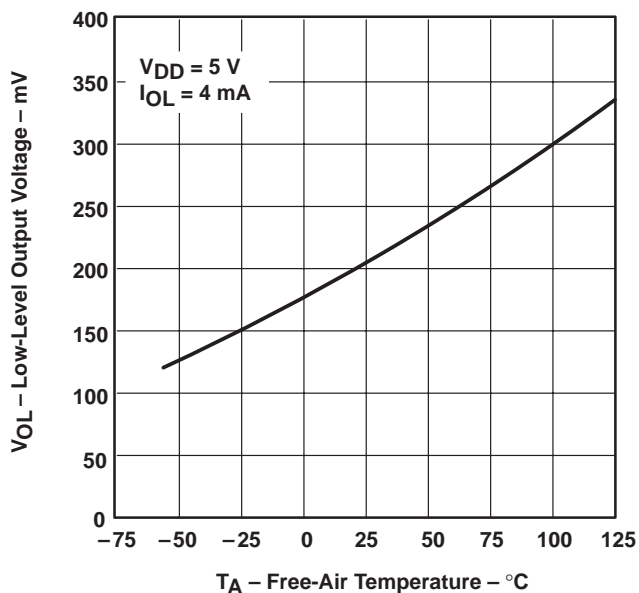

Figure 15

OUTPUT TRANSITION TIME
vs
LOAD CAPACITANCE

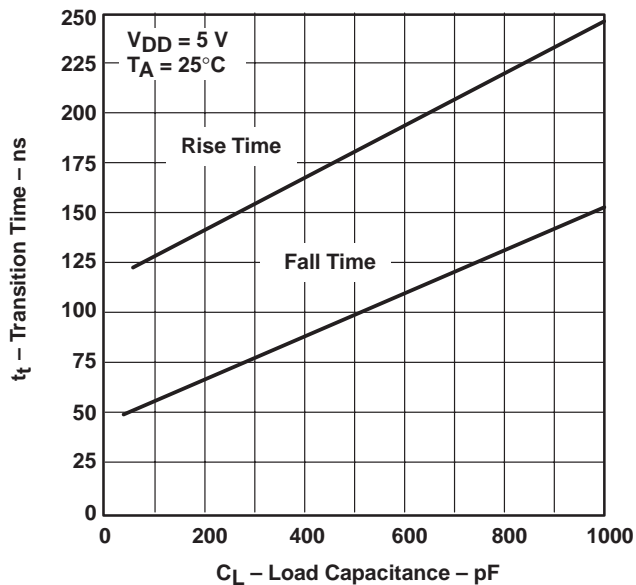

Figure 16

SUPPLY CURRENT RESPONSE
TO AN OUTPUT VOLTAGE TRANSITION

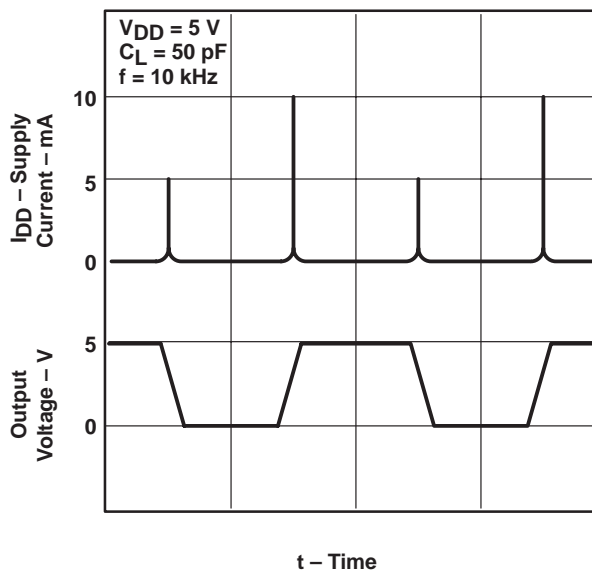

Figure 17

† Data at high and low temperatures are applicable only within the rated operating free-air temperature ranges of the various devices.

TLC3704, TLC3704Q

QUAD MICROPOWER LinCMOS™ VOLTAGE COMPARATORS

SLCS117A – NOVEMBER 1986 – REVISED OCTOBER 1996

TYPICAL CHARACTERISTICS

LOW-TO-HIGH-LEVEL OUTPUT RESPONSE FOR VARIOUS INPUT OVERDRIVES

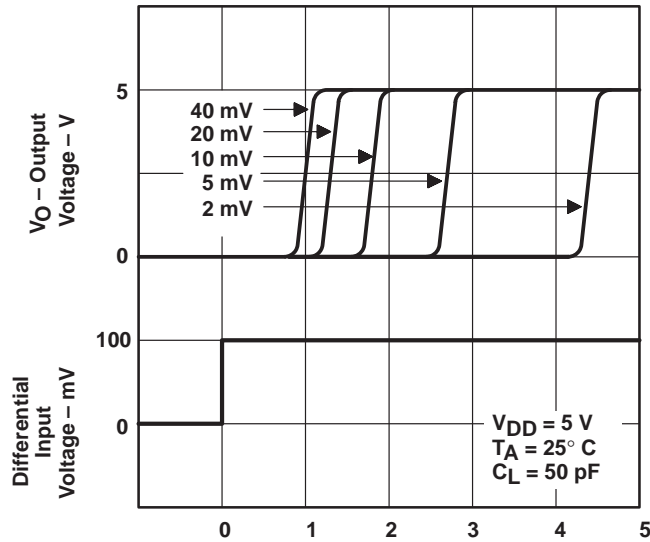

Figure 18

HIGH-TO-LOW-LEVEL OUTPUT RESPONSE FOR VARIOUS INPUT OVERDRIVES

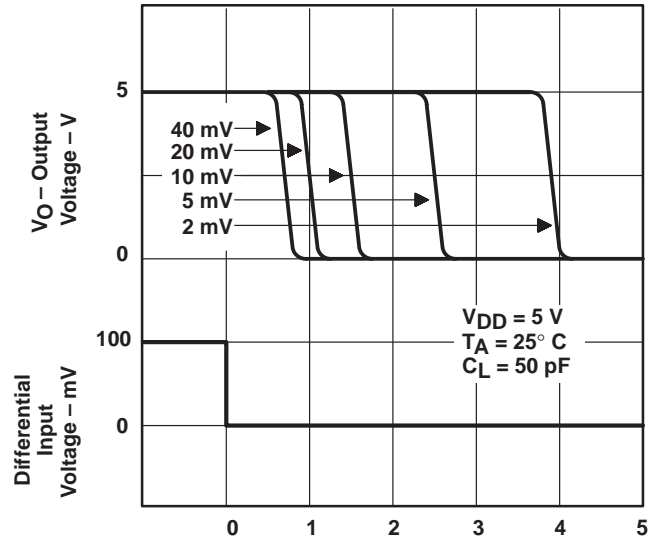

Figure 19

LOW-TO-HIGH-LEVEL OUTPUT RESPONSE TIME VS SUPPLY VOLTAGE

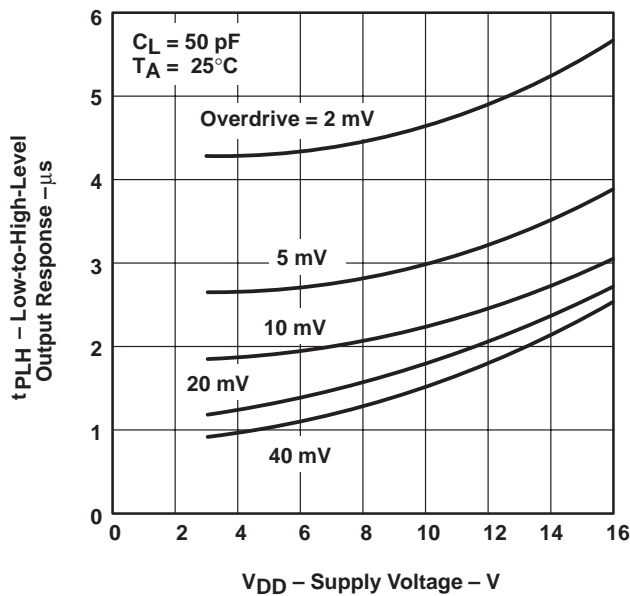

Figure 20

HIGH-TO-LOW-LEVEL OUTPUT RESPONSE TIME VS SUPPLY VOLTAGE

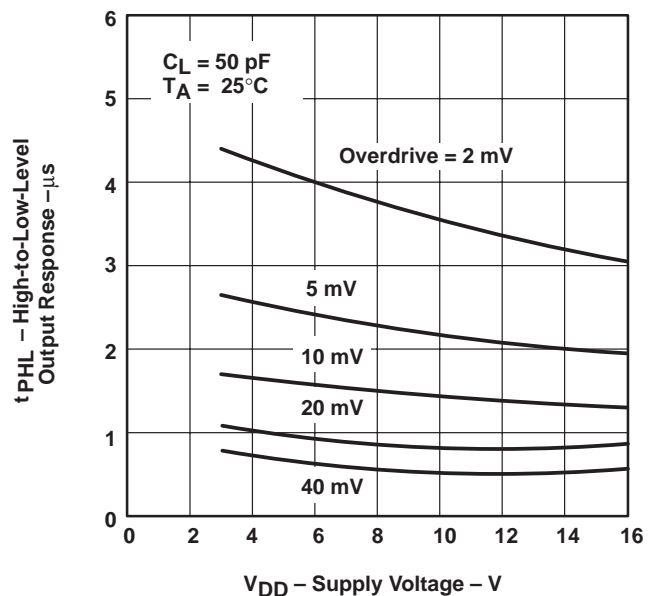

Figure 21

TLC3704, TLC3704Q QUAD MICROPOWER LinCMOS™ VOLTAGE COMPARATORS

SLCS117A – NOVEMBER 1986 – REVISED OCTOBER 1996

TYPICAL CHARACTERISTICS†

**AVERAGE SUPPLY CURRENT
(PER COMPARATOR)
vs
FREQUENCY**

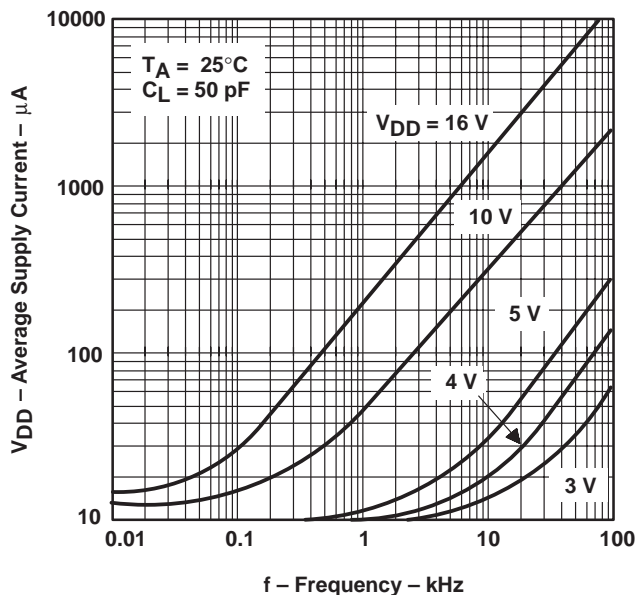

f – Frequency – kHz
Figure 22

**SUPPLY CURRENT
vs
SUPPLY VOLTAGE**

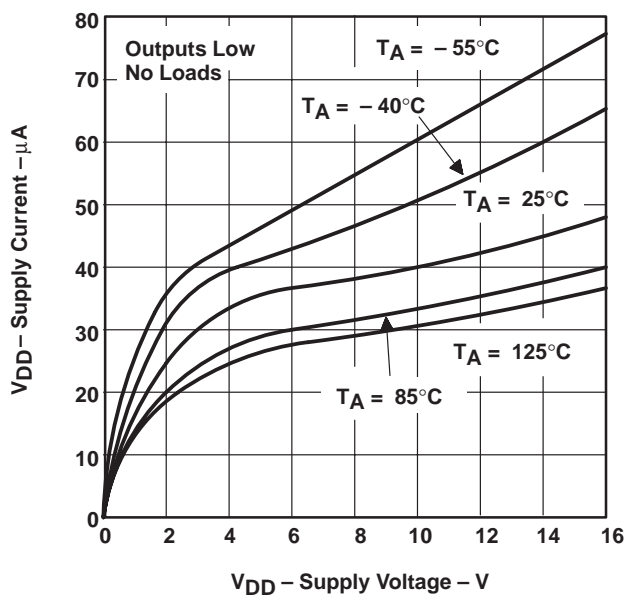

V_{DD} – Supply Voltage – V
Figure 23

**SUPPLY CURRENT
vs
FREE-AIR TEMPERATURE**

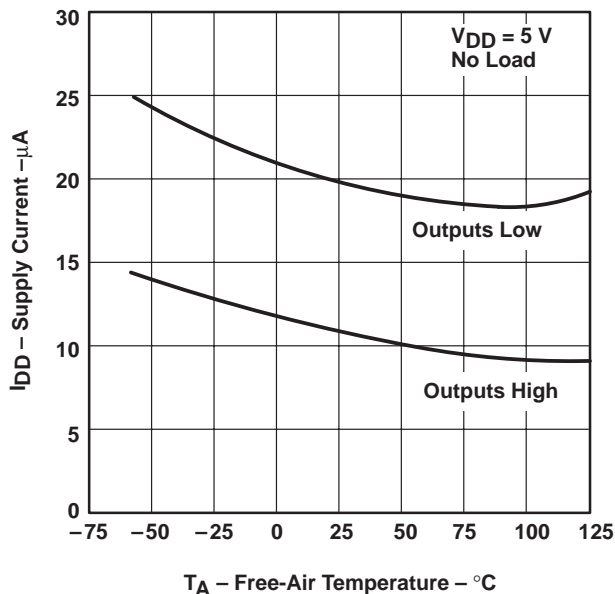

Figure 24

† Data at high and low temperatures are applicable only within the rated operating free-air temperature ranges of the various devices.

TLC3704, TLC3704Q QUAD MICROPOWER LinCMOS™ VOLTAGE COMPARATORS

SLCS117A – NOVEMBER 1986 – REVISED OCTOBER 1996

APPLICATION INFORMATION

The inputs should always remain within the supply rails in order to avoid forward biasing the diodes in the electrostatic discharge (ESD) protection structure. If either input exceeds this range, the device is not damaged as long as the input is limited to less than 5 mA. To maintain the expected output state, the inputs must remain within the common-mode range. For example, at 25°C with $V_{DD} = 5$ V, both inputs must remain between -0.2 V and 4 V to ensure proper device operation. To ensure reliable operation, the supply should be decoupled with a capacitor (0.1 μ F) that is positioned as close to the device as possible.

Output and supply current limitations should be watched carefully since the TLC3704 does not provide current protection. For example, each output can source or sink a maximum of 20 mA; however, the total current to ground can only be an absolute maximum of 60 mA. This prohibits sinking 20 mA from each of the four outputs simultaneously since the total current to ground would be 80 mA.

The TLC3704 has internal ESD-protection circuits that prevents functional failures at voltages up to 2000 V as tested under MIL-STD-883C, Method 3015.2; however, care should be exercised in handling these devices as exposure to ESD may result in the degradation of the device parametric performance.

Table of Applications

	FIGURE
Pulse-width-modulated motor speed controller	25
Enhanced supply supervisor	26
Two-phase nonoverlapping clock generator	27
Micropower switching regulator	28

TLC3704, TLC3704Q QUAD MICROPOWER LinCMOS™ VOLTAGE COMPARATORS

SLCS117A – NOVEMBER 1986 – REVISED OCTOBER 1996

APPLICATION INFORMATION

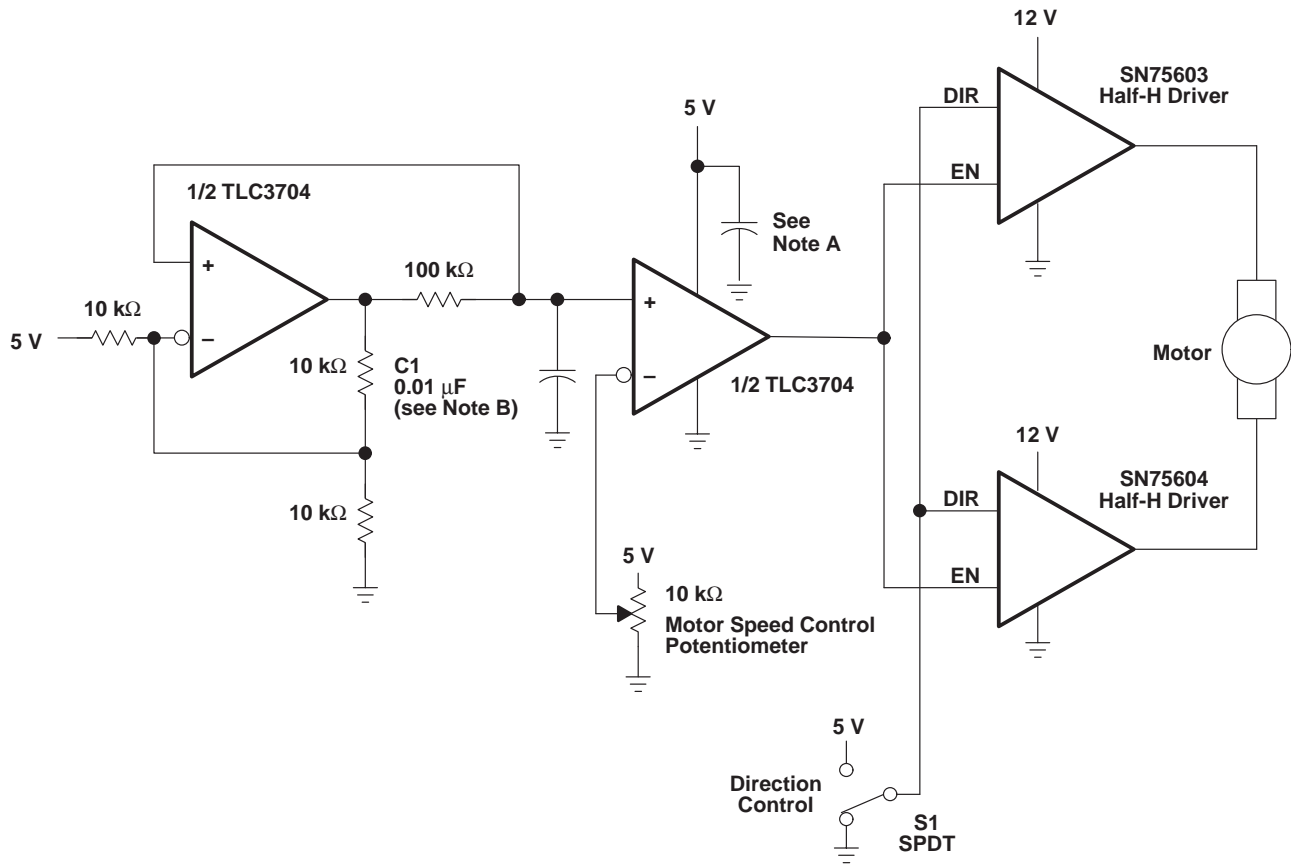

- NOTES: A. The recommended minimum capacitance is 10 μ F to eliminate common ground switching noise.
B. Adjust C1 for change in oscillator frequency

Figure 25. Pulse-Width-Modulated Motor Speed Controller

TLC3704, TLC3704Q QUAD MICROPOWER LinCMOS™ VOLTAGE COMPARATORS

SLCS117A – NOVEMBER 1986 – REVISED OCTOBER 1996

APPLICATION INFORMATION

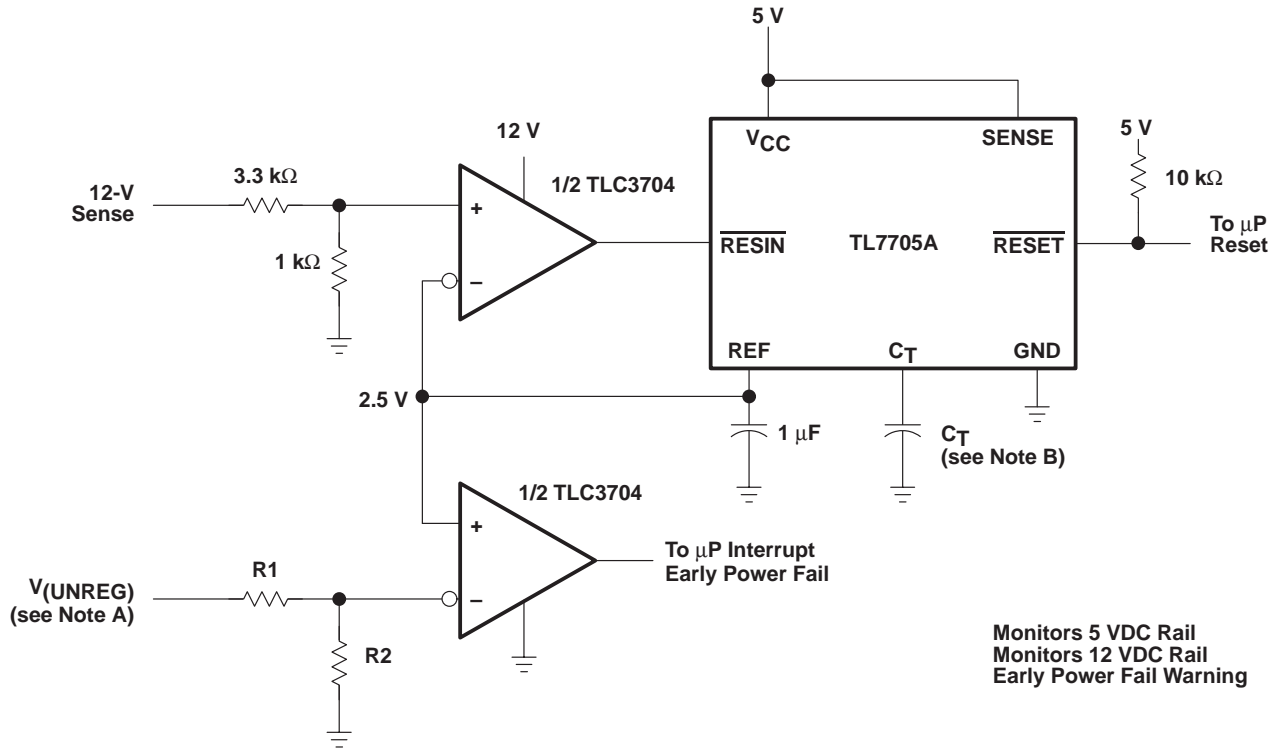

- NOTES: A. $V_{(UNREG)} = 2.5 \frac{(R1 + R2)}{R2}$
 B. The value of C_T determines the time delay of reset.

Figure 26. Enhanced Supply Supervisor

TLC3704, TLC3704Q

QUAD MICROPOWER LinCMOS™ VOLTAGE COMPARATORS

SLCS117A – NOVEMBER 1986 – REVISED OCTOBER 1996

APPLICATION INFORMATION

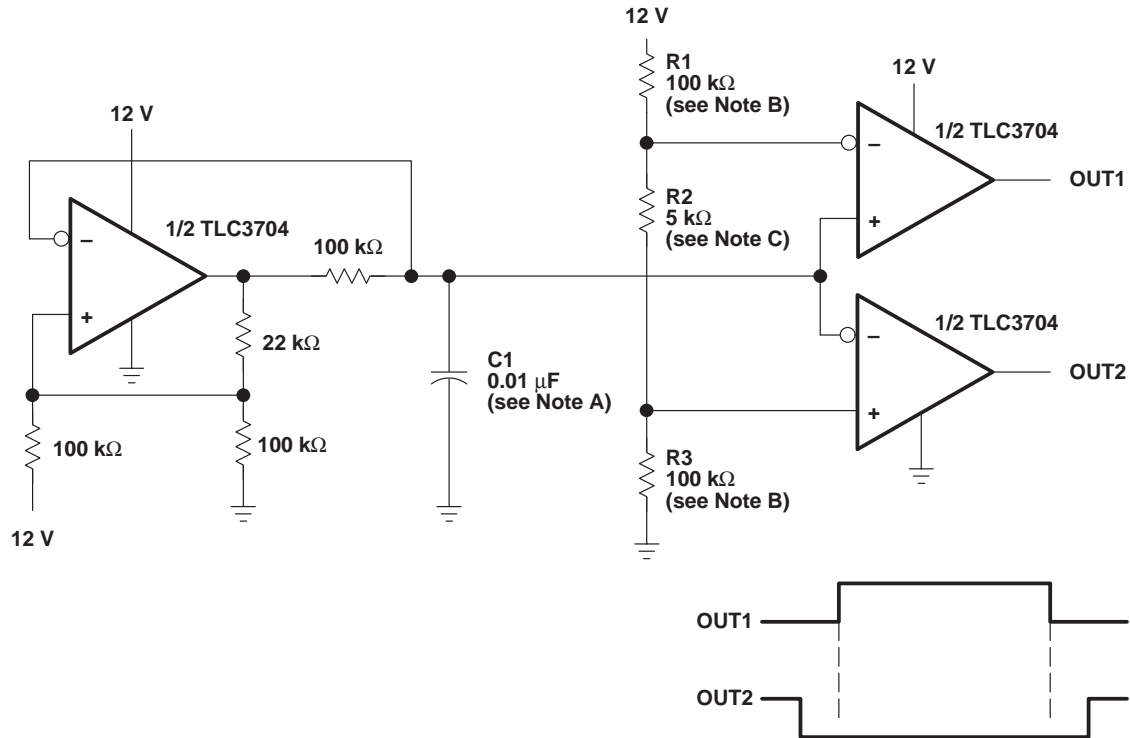

- NOTES: A. Adjust C1 for a change in oscillator frequency where:
 $1/f = 1.85(100 \text{ k}\Omega)C1$
 B. Adjust R1 and R3 to change duty cycle
 C. Adjust R2 to change deadtime

Figure 27. Two-Phase Nonoverlapping Clock Generator

TLC3704, TLC3704Q QUAD MICROPOWER LinCMOS™ VOLTAGE COMPARATORS

SLCS117A – NOVEMBER 1986 – REVISED OCTOBER 1996

APPLICATION INFORMATION

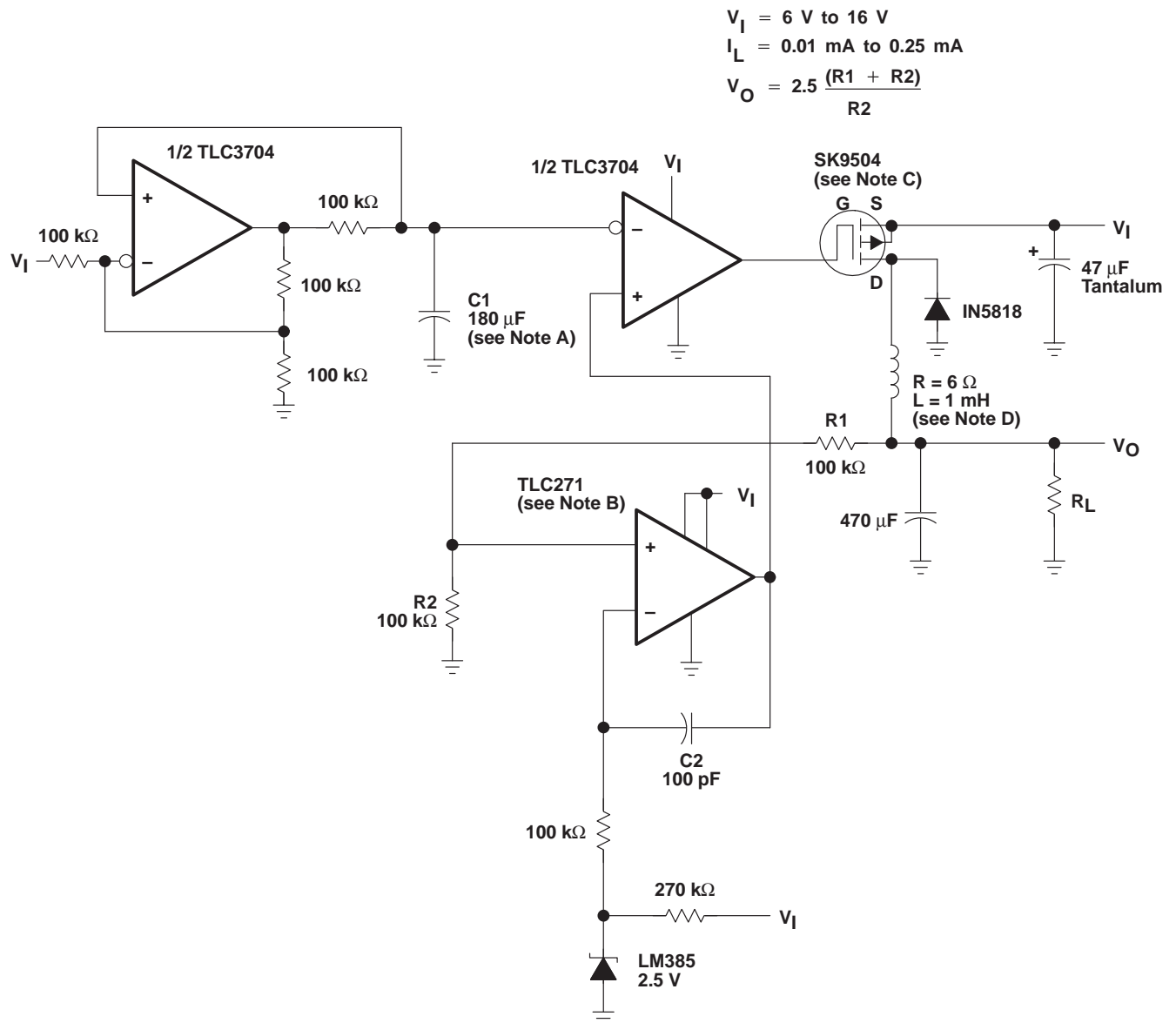

- NOTES: A. Adjust C1 for a change in oscillator frequency
 B. TLC271 – Tie pin 8 to pin 7 for low bias operation
 C. SK9504 – VDS = 40 V
 IDS = 1 A will
 D. To achieve microampere current drive, the inductance of the circuit must be increased.

Figure 28. Micropower Switching Regulator

IMPORTANT NOTICE

Texas Instruments and its subsidiaries (TI) reserve the right to make changes to their products or to discontinue any product or service without notice, and advise customers to obtain the latest version of relevant information to verify, before placing orders, that information being relied on is current and complete. All products are sold subject to the terms and conditions of sale supplied at the time of order acknowledgment, including those pertaining to warranty, patent infringement, and limitation of liability.

TI warrants performance of its semiconductor products to the specifications applicable at the time of sale in accordance with TI's standard warranty. Testing and other quality control techniques are utilized to the extent TI deems necessary to support this warranty. Specific testing of all parameters of each device is not necessarily performed, except those mandated by government requirements.

Customers are responsible for their applications using TI components.

In order to minimize risks associated with the customer's applications, adequate design and operating safeguards must be provided by the customer to minimize inherent or procedural hazards.

TI assumes no liability for applications assistance or customer product design. TI does not warrant or represent that any license, either express or implied, is granted under any patent right, copyright, mask work right, or other intellectual property right of TI covering or relating to any combination, machine, or process in which such semiconductor products or services might be or are used. TI's publication of information regarding any third party's products or services does not constitute TI's approval, warranty or endorsement thereof.