

- Meets or Exceeds the Requirements of ANSI EIA/TIA-422-B and -423-B
- Meets or Exceeds the Requirements of ANSI EIA/TIA-232-E and ITU Recommendation V.28 With External Components
- Meets Federal Standards 1020 and 1030
- Built-in 5-MHz Low-Pass Filter
- Operates From Single 5-V Power Supply
- Wide Common-Mode Voltage Range
- High Input Impedance
- TTL-Compatible Outputs
- 8-Pin Dual-in-Line Package
- Pinout Compatible With the μ A9637 and μ A9639

D OR P PACKAGE
(TOP VIEW)

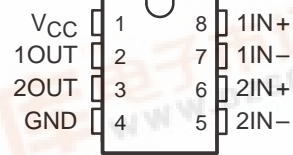

THE SN75146 IS NOT RECOMMENDED FOR NEW DESIGNS.

description

The SN75146 is a dual differential line receiver designed to meet ANSI Standards EIA/TIA-422-B and -423-B. The receiver is designed to have a constant impedance with input voltages of ± 3 V to ± 25 V allowing it to meet the requirements of EIA/TIA-232-E and ITU recommendation V.28 with the addition of an external bias resistor. This receiver is designed for low-speed operation below 355 kHz and has a built-in 5-MHz low-pass filter to attenuate high-frequency noise. The inputs are compatible with either a single-ended or a differential line system and the outputs are TTL compatible. This device operates from a single 5-V power supply and is supplied in both the 8-pin dual-in-line and small-outline packages.

The SN75146 is characterized for operation from 0°C to 70°C.

logic symbol†

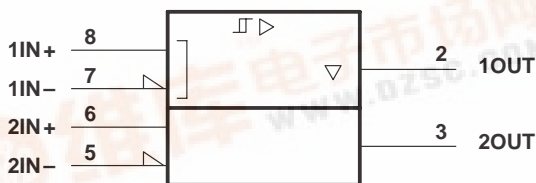

† This symbol is in accordance with ANSI/IEEE Std 91-1984 and IEC Publication 617-12.

logic diagram

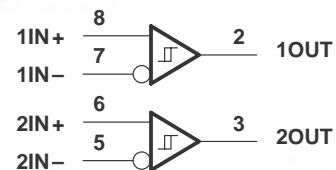

Please be aware that an important notice concerning availability, standard warranty, and use in critical applications of Texas Instruments semiconductor products and disclaimers thereto appears at the end of this data sheet.

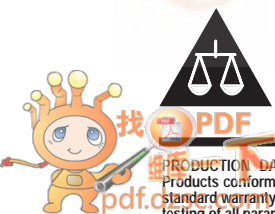

SN75146 DUAL DIFFERENTIAL LINE RECEIVER

SLLS015B – FEBRUARY 1986 – REVISED MAY 1995

schematics of inputs and outputs

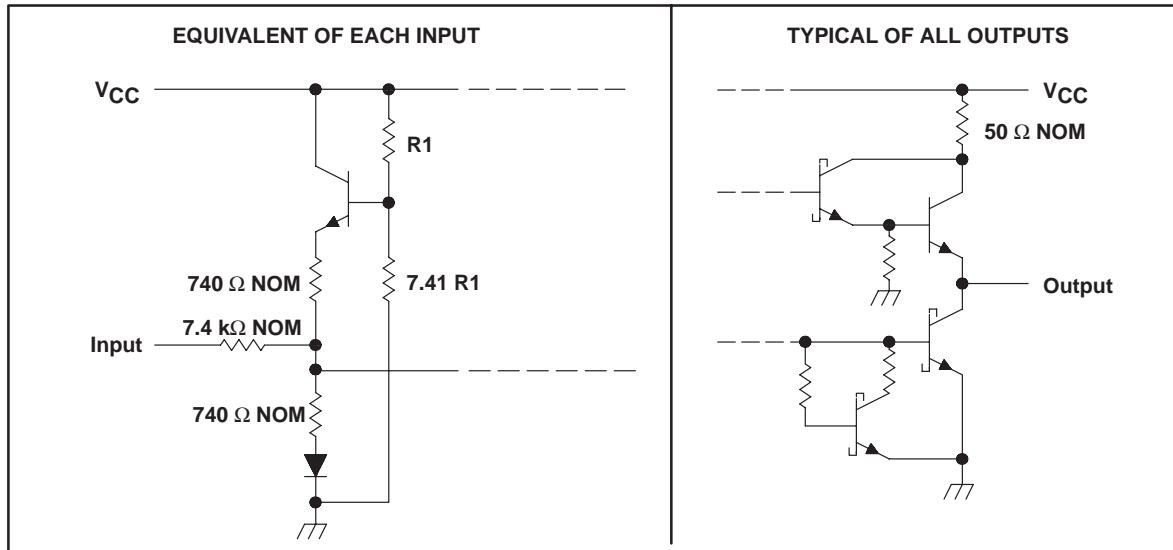

absolute maximum ratings over operating free-air temperature range (unless otherwise noted)†

Supply voltage range, V_{CC} (see Note 1)	−0.5 V to 7 V
Input voltage, V_I	±25 V
Differential input voltage, V_{ID} (see Note 2)	±25 V
Output voltage range, V_O (see Note 1)	−0.5 V to 5.5 V
Low-level output current, I_{OL}	50 mA
Continuous total dissipation	See Dissipation Rating Table
Operating free-air temperature range, T_A	0°C to 70°C
Storage temperature range, T_{stg}	−65°C to 150°C
Lead temperature 1,6 mm (1/16 inch) from case for 10 seconds	260°C

† Stresses beyond those listed under “absolute maximum ratings” may cause permanent damage to the device. These are stress ratings only, and functional operation of the device at these or any other conditions beyond those indicated under “recommended operating conditions” is not implied. Exposure to absolute-maximum-rated conditions for extended periods may affect device reliability.

- NOTES: 1. All voltage values, except differential input voltage, are with respect to the network ground terminal.
2. Differential input voltage is measured at the noninverting input with respect to the corresponding inverting input.

DISSIPATION RATING TABLE

PACKAGE	$T_A \leq 25^\circ\text{C}$ POWER RATING	OPERATING FACTOR ABOVE $T_A = 25^\circ\text{C}$	$T_A = 70^\circ\text{C}$ POWER RATING
D	725 mW	5.8 mW/°C	464 mW
P	1000 mW	8.0 mW/°C	640 mW

recommended operating conditions

	MIN	NOM	MAX	UNIT
Supply voltage, V_{CC}	4.75	5	5.25	V
Common-mode input voltage, V_{IC}			±7	V
Operating free-air temperature, T_A	0	25	70	°C

SN75146 DUAL DIFFERENTIAL LINE RECEIVER

SLLS015B – FEBRUARY 1986 – REVISED MAY 1995

electrical characteristics over recommended ranges of supply voltage, common-mode input voltage, and operating free-air temperature (unless otherwise noted)

PARAMETER	TEST CONDITIONS	MIN	TYP†	MAX	UNIT
V_{IT} Threshold input voltage (V_{IT+} and V_{IT-})		-0.2‡		0.2	V
	See Note 3	-0.4‡		0.4	
V_{hys} Hysteresis ($V_{IT+} - V_{IT-}$)		70			mV
V_{IB} Input bias voltage	$I_I = 0$	2		2.4	V
V_{OH} High-level output voltage	$V_{ID} = 0.2$ V, $I_O = -1$ mA	2.5	3.5		V
V_{OL} Low-level output voltage	$V_{ID} = -0.2$ V, $I_O = 20$ mA		0.35	0.5	V
r_i Input resistance	$V_I = 3$ V to 25 V or $V_I = -3$ V to -25 V, See Note 4	6	7.8	10.5	k Ω
I_I Input current	$V_{CC} = 0$ to 5.5 V, See Note 5	$V_I = 10$ V	1.1	3.25	mA
		$V_I = -10$ V	-1.6	-3.25	
I_{OS} Short-circuit output current§	$V_O = 0$, $V_{ID} = 0.2$ V	-40	-75	-100	mA
I_{CC} Supply current	$V_{ID} = -0.5$ V, No load		35	50	mA

† All typical values are at $V_{CC} = 5$ V, $T_A = 25^\circ\text{C}$.

‡ The algebraic convention, in which the less positive (more negative) limit is designated as minimum, is used in this data sheet for threshold levels only.

§ Only one output should be shorted at a time, and duration of the short circuit should not exceed one second.

NOTES: 3. The expanded threshold parameter is tested with a 500- Ω resistor in series with each input.

4. r_i is defined by $\Delta V_I / \Delta I_I$.

5. The input not under test is grounded.

switching characteristics, $V_{CC} = 5$ V, $T_A = 25^\circ\text{C}$

PARAMETER	TEST CONDITIONS	MIN	TYP	MAX	UNIT
t_{PLH} Propagation delay time, low-to-high-level output	$C_L = 30$ pF, See Figure 1	100	150	300	ns
t_{PHL} Propagation delay time, high-to-low-level output		100	150	300	ns

PARAMETER MEASUREMENT INFORMATION

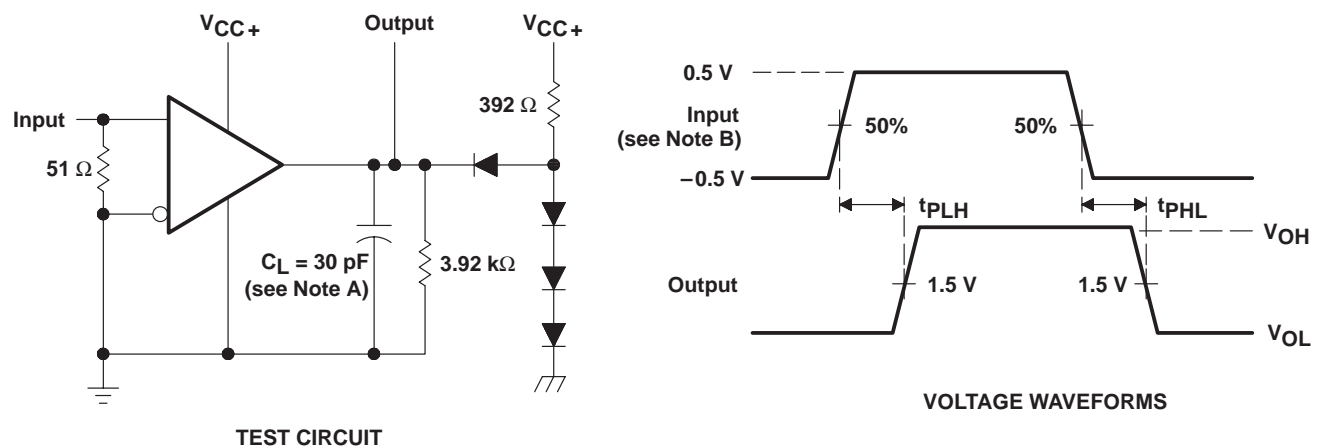

NOTES: A. C_L includes probe and jig capacitance.

B. The input pulse is supplied by a generator having the following characteristics: $t_r \leq 5$ ns, $t_f \leq 5$ ns, $PRR \leq 300$ kHz, duty cycle = 50%.

Figure 1. Test Circuit and Voltage Waveforms

SN75146 DUAL DIFFERENTIAL LINE RECEIVER

SLLS015B – FEBRUARY 1986 – REVISED MAY 1995

TYPICAL CHARACTERISTICS

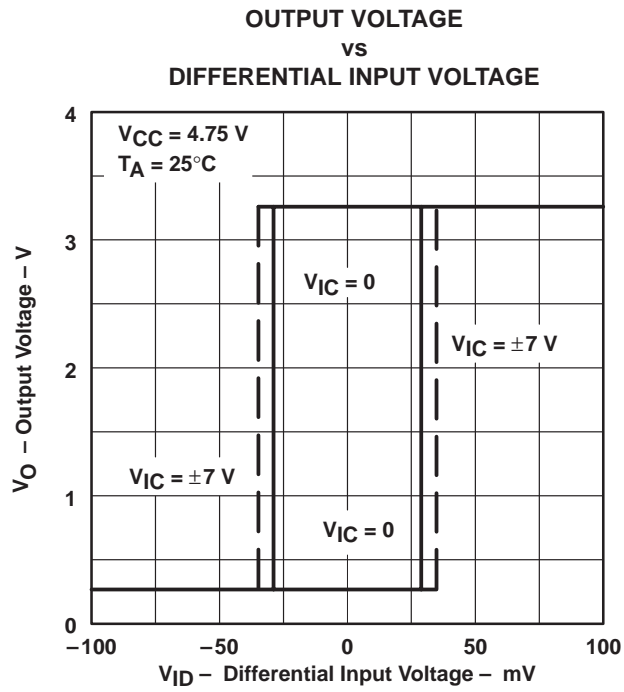

Figure 2

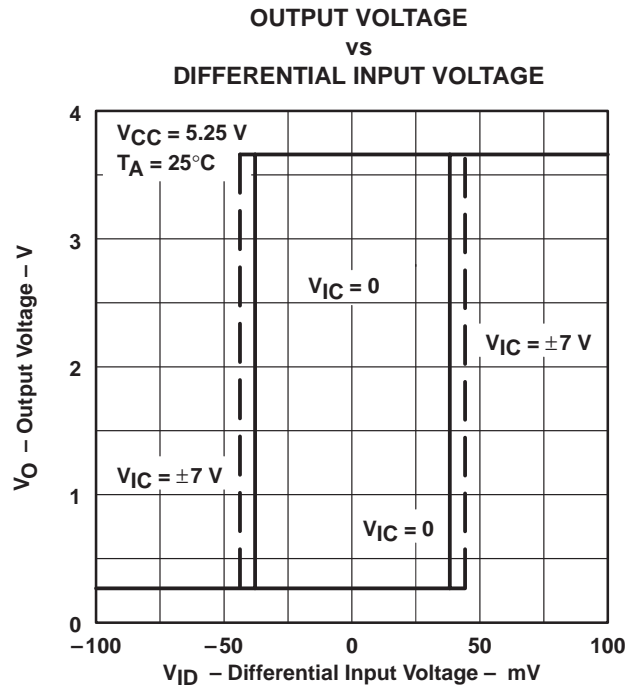
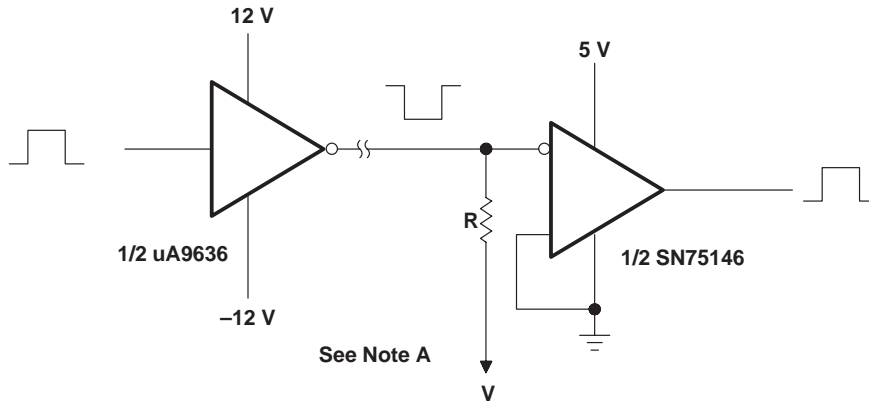

Figure 3

SN75146 DUAL DIFFERENTIAL LINE RECEIVER

SLLS015B – FEBRUARY 1986 – REVISED MAY 1995

APPLICATION INFORMATION



NOTE A: In order to meet the input-impedance and open-circuit-input voltage requirements of ANSI Standard EIA/TIA-232-E and ITU recommendation V.28 and ensure open-circuit-input fail-safe operation, R and V are selected to satisfy the following equations:

$$V = -1.1 - 3.3 \frac{R}{r_i} \text{ volts}$$

$$3 \text{ k}\Omega \leq \frac{R(r_i)}{R + r_i} \leq 7 \text{ k}\Omega$$

Figure 4. EIA/TIA-232-E System Applications

SN75146 DUAL DIFFERENTIAL LINE RECEIVER

SLLS015B – FEBRUARY 1986 – REVISED MAY 1995

APPLICATION INFORMATION

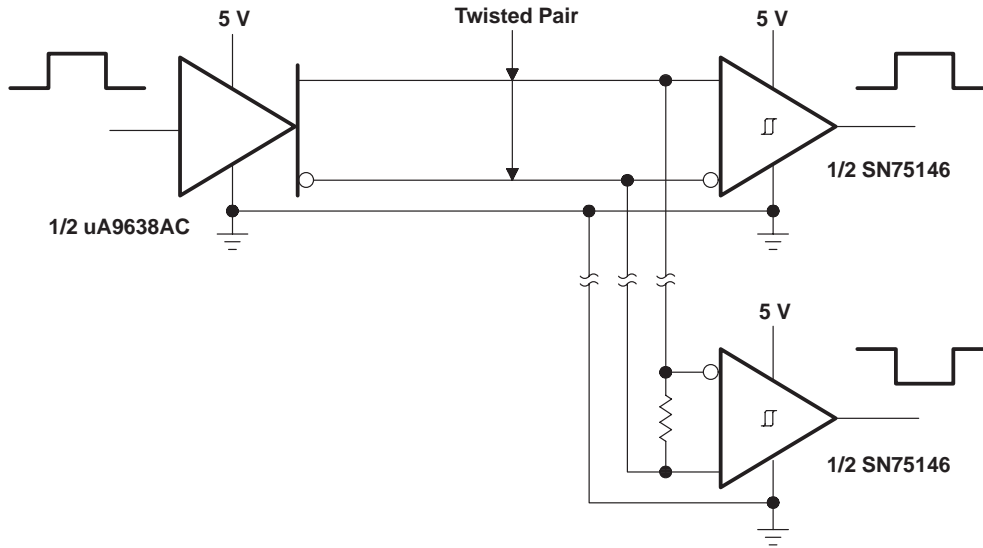

Figure 5. EIA/TIA-422-B System Applications

IMPORTANT NOTICE

Texas Instruments and its subsidiaries (TI) reserve the right to make changes to their products or to discontinue any product or service without notice, and advise customers to obtain the latest version of relevant information to verify, before placing orders, that information being relied on is current and complete. All products are sold subject to the terms and conditions of sale supplied at the time of order acknowledgement, including those pertaining to warranty, patent infringement, and limitation of liability.

TI warrants performance of its semiconductor products to the specifications applicable at the time of sale in accordance with TI's standard warranty. Testing and other quality control techniques are utilized to the extent TI deems necessary to support this warranty. Specific testing of all parameters of each device is not necessarily performed, except those mandated by government requirements.

CERTAIN APPLICATIONS USING SEMICONDUCTOR PRODUCTS MAY INVOLVE POTENTIAL RISKS OF DEATH, PERSONAL INJURY, OR SEVERE PROPERTY OR ENVIRONMENTAL DAMAGE ("CRITICAL APPLICATIONS"). TI SEMICONDUCTOR PRODUCTS ARE NOT DESIGNED, AUTHORIZED, OR WARRANTED TO BE SUITABLE FOR USE IN LIFE-SUPPORT DEVICES OR SYSTEMS OR OTHER CRITICAL APPLICATIONS. INCLUSION OF TI PRODUCTS IN SUCH APPLICATIONS IS UNDERSTOOD TO BE FULLY AT THE CUSTOMER'S RISK.

In order to minimize risks associated with the customer's applications, adequate design and operating safeguards must be provided by the customer to minimize inherent or procedural hazards.

TI assumes no liability for applications assistance or customer product design. TI does not warrant or represent that any license, either express or implied, is granted under any patent right, copyright, mask work right, or other intellectual property right of TI covering or relating to any combination, machine, or process in which such semiconductor products or services might be or are used. TI's publication of information regarding any third party's products or services does not constitute TI's approval, warranty or endorsement thereof.