

- Meets or Exceeds the Requirements of ANSI Standards EIA/TIA-422-B and EIA/TIA-423-B and ITU Recommendation V.10 and V.11
- Operates From Single 5-V Power Supply
- Wide Common-Mode Voltage Range
- High Input Impedance
- TTL-Compatible Outputs
- High-Speed Schottky Circuitry
- 8-Pin Dual-In-Line Package

D or P PACKAGE  
(TOP VIEW)

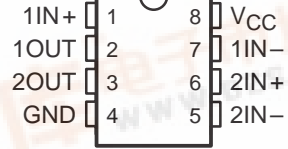

### description

The SN75157 is a dual differential line receiver designed to meet Standards EIA/TIA-422-B and -423-B and ITU V.10 and V.11. It utilizes Schottky circuitry and has TTL-compatible outputs. The inputs are compatible with either a single-ended or a differential-line system. The device operates from a single 5-V power supply and is supplied in 8-pin dual-in-line and small-outline packages.

The SN75157 is characterized for operation from 0°C to 70°C.

### logic symbol†

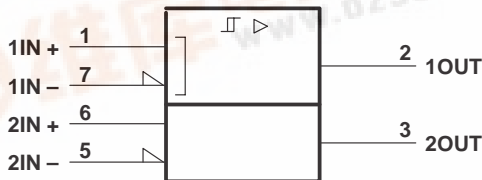

† This symbol is in accordance with ANSI/IEEE Std 91-1984 and IEC Publication 617-12.

### logic diagram (positive logic)

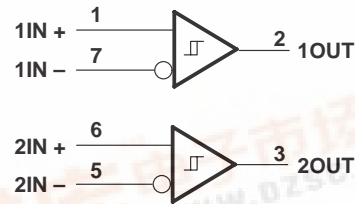

Please be aware that an important notice concerning availability, standard warranty, and use in critical applications of Texas Instruments semiconductor products and disclaimers thereto appears at the end of this data sheet.

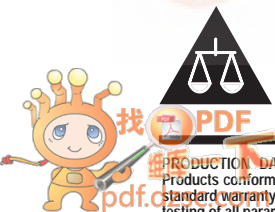

# SN75157 DUAL DIFFERENTIAL LINE RECEIVER

SLLS084C – SEPTEMBER 1980 – REVISED MARCH 1997

## schematics of inputs and outputs

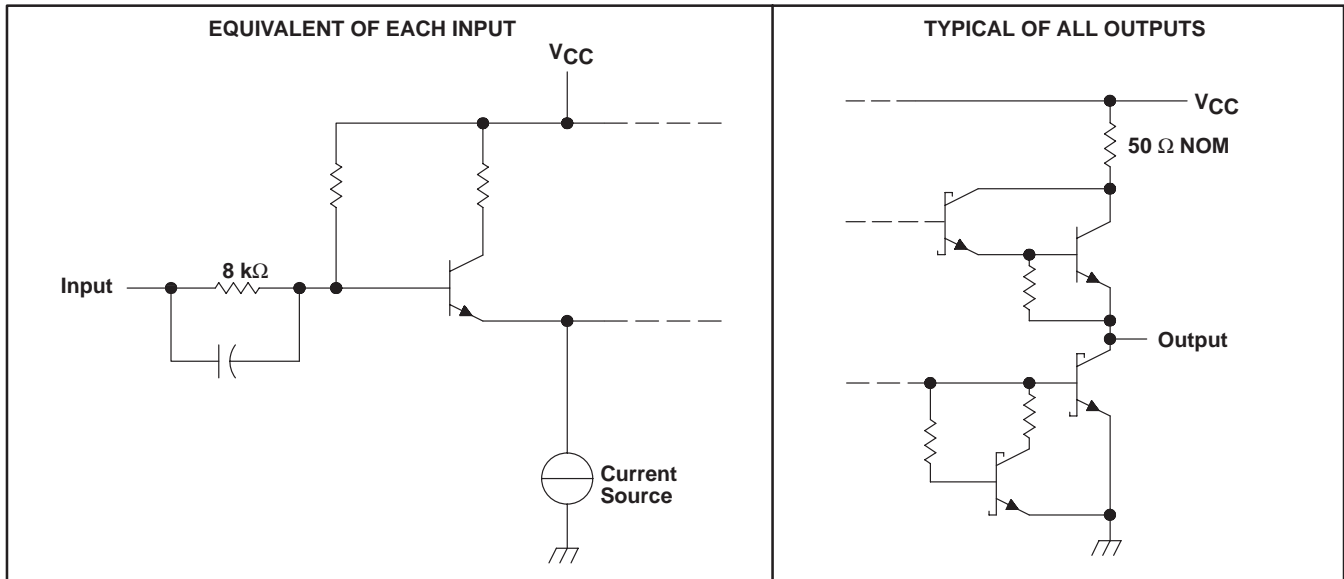

## absolute maximum ratings over operating free-air temperature range (unless otherwise noted)†

Supply voltage range, $V_{CC}$ (see Note 1)	−0.5 V to 7 V
Input voltage, $V_I$	±15 V
Differential input voltage, $V_{ID}$ (see Note 2)	±15 V
Output voltage range, $V_O$ (see Note 1)	−0.5 V to 5.5 V
Low-level output current, $I_{OL}$	50 mA
Continuous total dissipation	See Dissipation Rating Table
Operating free-air temperature range, $T_A$	0°C to 70°C
Storage temperature range, $T_{stg}$	−65°C to 150°C
Lead temperature 1,6 mm (1/16 inch) from case for 10 seconds	260°C

† Stresses beyond those listed under “absolute maximum ratings” may cause permanent damage to the device. These are stress ratings only, and functional operation of the device at these or any other conditions beyond those indicated under “recommended operating conditions” is not implied. Exposure to absolute-maximum-rated conditions for extended periods may affect device reliability.

- NOTES: 1. All voltage values, except differential input voltage, are with respect to the network ground terminal.  
2. Differential input voltage is measured at the noninverting input with respect to the corresponding inverting input.

DISSIPATION RATING TABLE

PACKAGE	$T_A \leq 25^\circ\text{C}$ POWER RATING	OPERATING FACTOR ABOVE $T_A = 25^\circ\text{C}$	$T_A = 70^\circ\text{C}$ POWER RATING
D	725 mW	5.8 mW/°C	464 mW
P	1000 mW	8.0 mW/°C	640 mW

## recommended operating conditions

	MIN	NOM	MAX	UNIT
Supply voltage, $V_{CC}$	4.75	5	5.25	V
Common-mode input voltage, $V_{IC}$			±7	V
Operating free-air temperature, $T_A$	0	25	70	°C

# SN75157 DUAL DIFFERENTIAL LINE RECEIVER

SLLS084C – SEPTEMBER 1980 – REVISED MARCH 1997

**electrical characteristics over recommended ranges of supply voltage, common-mode input voltage, and operating free-air temperature (unless otherwise noted)†**

PARAMETER		TEST CONDITIONS	MIN	TYP‡	MAX	UNIT
$V_{IT}$	Input threshold voltage ( $V_{IT+}$ and $V_{IT-}$ )		-0.2		0.2	V
		See Note 3	-0.4		0.4	
$V_{hys}$	Hysteresis voltage ( $V_{IT+} - V_{IT-}$ )			70		mV
$V_{OH}$	High-level output voltage	$V_{ID} = 0.2$ V, $I_O = -1$ mA	2.5	3.5		V
$V_{OL}$	Low-level output voltage	$V_{ID} = -0.2$ V, $I_O = 20$ mA		0.35	0.5	V
$I_I$	Input current	$V_{CC} = 0$ to 5.5 V, See Note 4	$V_I = 10$ V	1.1	3.25	mA
			$V_I = -10$ V	-1.6	-3.25	
$I_{OS}$	Short-circuit output current§	$V_O = 0$ , $V_{ID} = 0.2$ V	-40	-75	-100	mA
$I_{CC}$	Supply current	$V_{ID} = -0.5$ V, No load		35	50	mA

† The algebraic convention, where the less positive (more negative) limit is designated as minimum, is used in this data sheet for threshold levels only.

‡ All typical values are at  $V_{CC} = 5$  V,  $T_A = 25^\circ\text{C}$ .

§ Only one output should be shorted at a time and duration of the short circuit should not exceed one second.

NOTES: 3. The expanded threshold parameter is tested with a 500- $\Omega$  resistor in series with each input.

4. The input not under test is grounded.

## switching characteristics, $V_{CC} = 5$ V, $T_A = 25^\circ\text{C}$

PARAMETER		TEST CONDITIONS	MIN	TYP	MAX	UNIT
$t_{PLH}$	Propagation delay time, low- to high-level output	$C_L = 15$ pF, See Figure 1		15	25	ns
$t_{PHL}$	Propagation delay time, high- to low-level output			13	25	

## PARAMETER MEASUREMENT INFORMATION

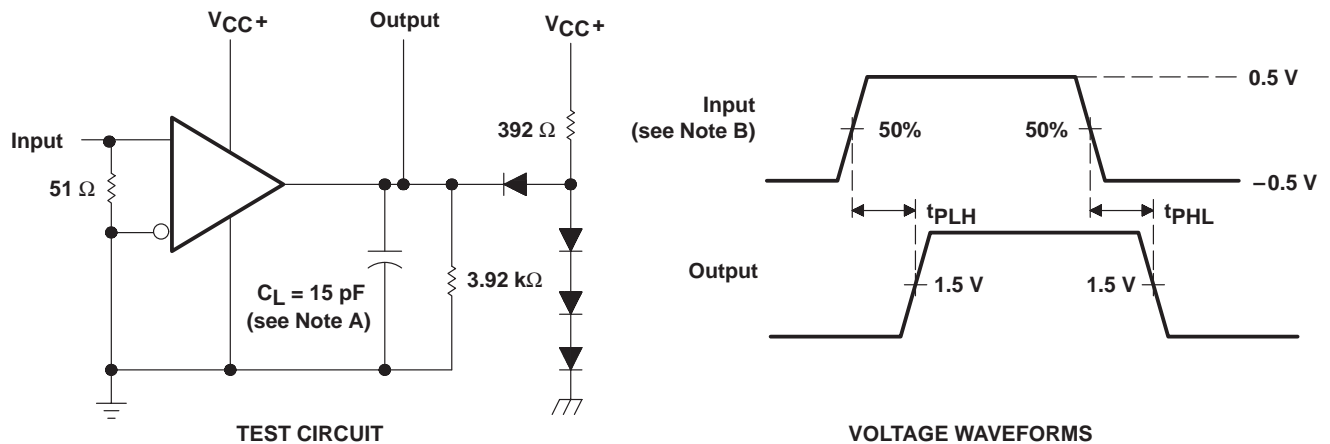

NOTES: A.  $C_L$  includes probe and jig capacitance.

B. The input pulse is supplied by a generator having the following characteristics:  $t_r \leq 5$  ns,  $t_f \leq 5$  ns,  $PRR \leq 5$  MHz, duty cycle = 50%.

**Figure 1. Test Circuit and Voltage Waveforms**

# SN75157 DUAL DIFFERENTIAL LINE RECEIVER

SLLS084C – SEPTEMBER 1980 – REVISED MARCH 1997

## TYPICAL CHARACTERISTICS

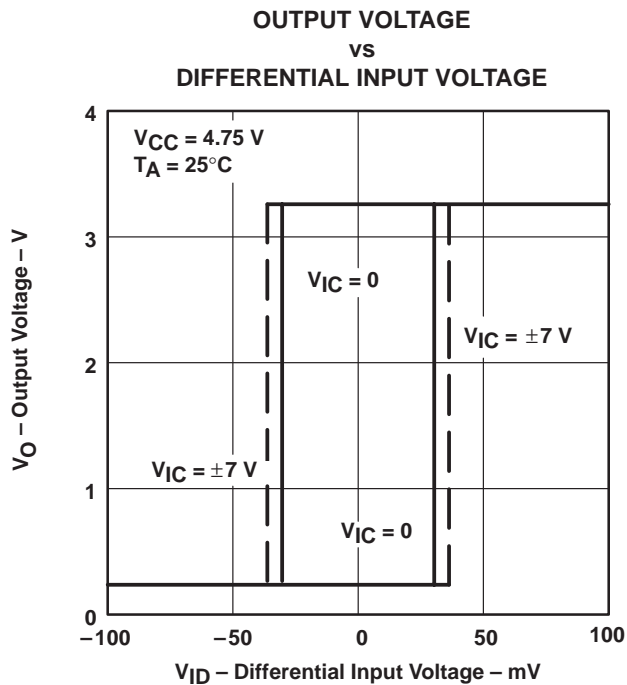

Figure 2

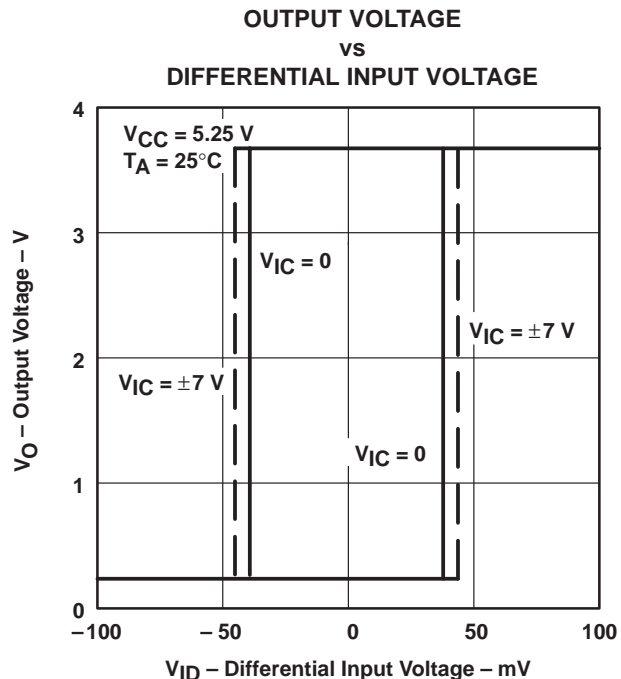

Figure 3

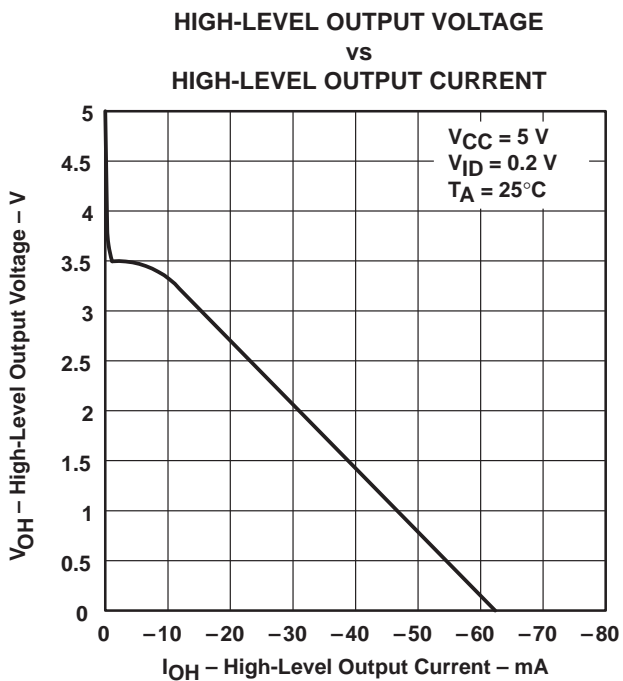

Figure 4

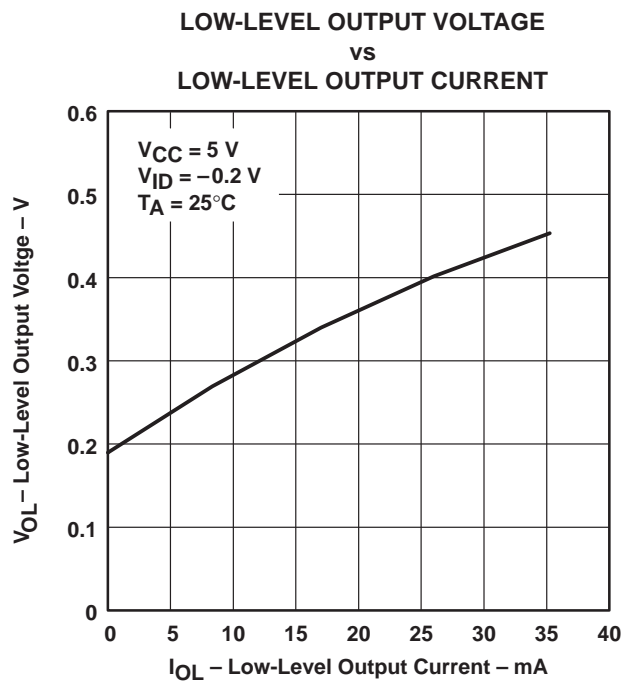

Figure 5

# SN75157 DUAL DIFFERENTIAL LINE RECEIVER

SLLS084C – SEPTEMBER 1980 – REVISED MARCH 1997

## TYPICAL CHARACTERISTICS

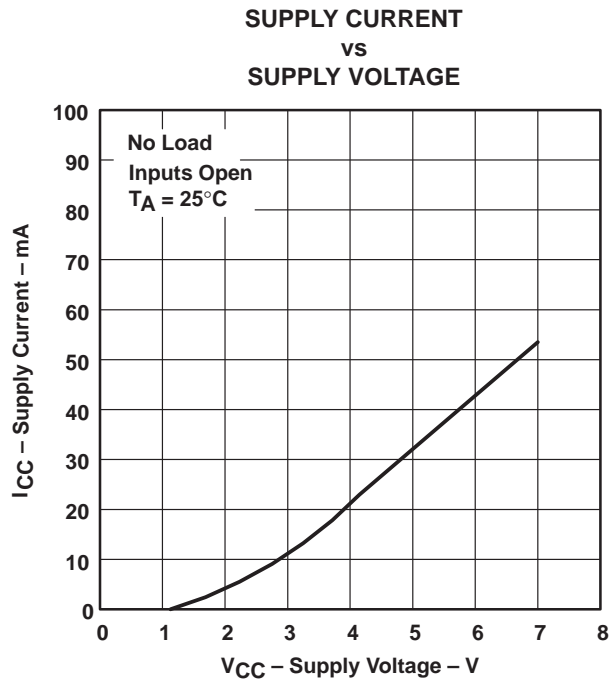

Figure 6

## APPLICATION INFORMATION

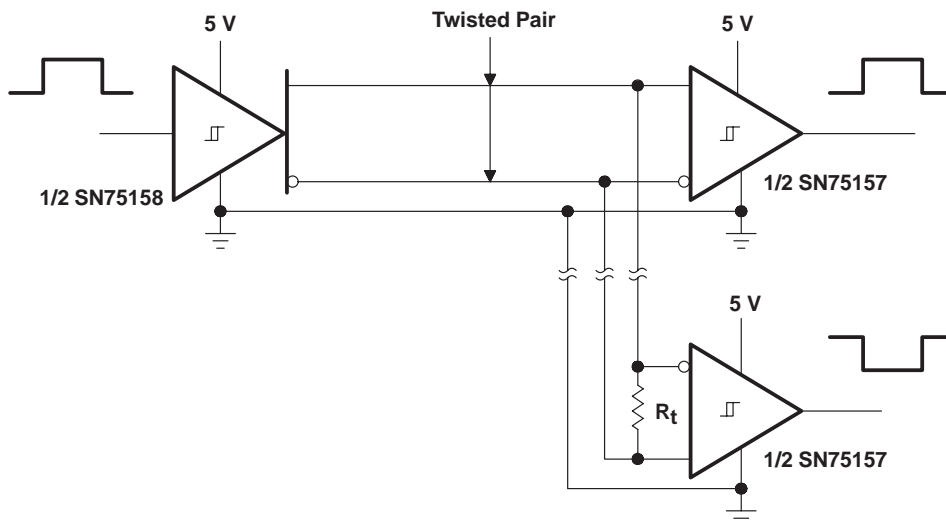

Figure 7. EIA/TIA-422-B System Application

## **IMPORTANT NOTICE**

Texas Instruments and its subsidiaries (TI) reserve the right to make changes to their products or to discontinue any product or service without notice, and advise customers to obtain the latest version of relevant information to verify, before placing orders, that information being relied on is current and complete. All products are sold subject to the terms and conditions of sale supplied at the time of order acknowledgement, including those pertaining to warranty, patent infringement, and limitation of liability.

TI warrants performance of its semiconductor products to the specifications applicable at the time of sale in accordance with TI's standard warranty. Testing and other quality control techniques are utilized to the extent TI deems necessary to support this warranty. Specific testing of all parameters of each device is not necessarily performed, except those mandated by government requirements.

CERTAIN APPLICATIONS USING SEMICONDUCTOR PRODUCTS MAY INVOLVE POTENTIAL RISKS OF DEATH, PERSONAL INJURY, OR SEVERE PROPERTY OR ENVIRONMENTAL DAMAGE ("CRITICAL APPLICATIONS"). TI SEMICONDUCTOR PRODUCTS ARE NOT DESIGNED, AUTHORIZED, OR WARRANTED TO BE SUITABLE FOR USE IN LIFE-SUPPORT DEVICES OR SYSTEMS OR OTHER CRITICAL APPLICATIONS. INCLUSION OF TI PRODUCTS IN SUCH APPLICATIONS IS UNDERSTOOD TO BE FULLY AT THE CUSTOMER'S RISK.

In order to minimize risks associated with the customer's applications, adequate design and operating safeguards must be provided by the customer to minimize inherent or procedural hazards.

TI assumes no liability for applications assistance or customer product design. TI does not warrant or represent that any license, either express or implied, is granted under any patent right, copyright, mask work right, or other intellectual property right of TI covering or relating to any combination, machine, or process in which such semiconductor products or services might be or are used. TI's publication of information regarding any third party's products or services does not constitute TI's approval, warranty or endorsement thereof.