

- Very Low Power Requirements
- Very Low Input Current
- Characterized for Use to 350 mA
- No Output Latch-Up at 50 V (After Conducting 300 mA)
- High-Voltage Outputs (70 V Min)
- Output Clamp Diodes for Transient Suppression (350 mA, 70 V)
- TTL- or MOS-Compatible Diode-Clamped Inputs
- Standard Supply Voltage
- Suitable for Hammer-Driver Applications

description

The SN75446 and SN75447 dual peripheral drivers are designed for use in systems that require high current, high voltage, and fast switching times. The SN75446 and SN75447 provide AND and NAND drivers, respectively. These devices have diode-clamped inputs as well as high-current, high-voltage inductive-clamp diodes on the outputs.

The SN75446 and SN75447 drivers are characterized for operation from 0°C to 70°C.

**D OR P PACKAGE
(TOP VIEW)**

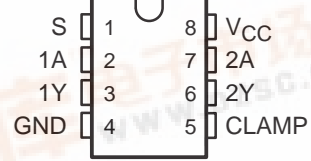

Function Tables

**SN75446
(each AND driver)**

INPUTS		OUTPUT
A	S	Y
H	H	H
L	X	L
X	L	L

**SN75447
(each NAND driver)**

INPUTS		OUTPUT
A	S	Y
H	H	L
L	X	H
X	L	H

H = high level, L = low level
 X = irrelevant

schematics of inputs and outputs

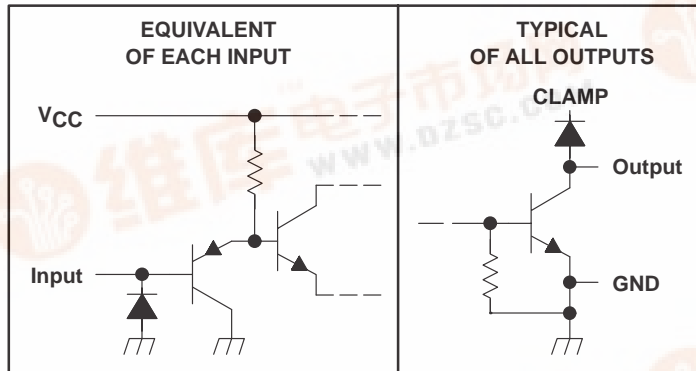

SN75446, SN75447 DUAL PERIPHERAL DRIVERS

SLRS020A – DECEMBER 1978 – REVISED NOVEMBER 1995

logic symbols†

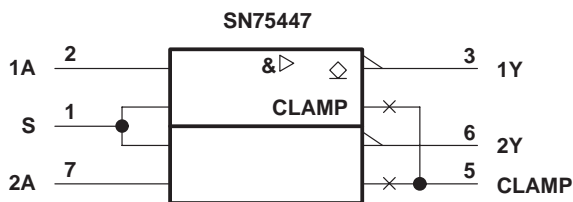
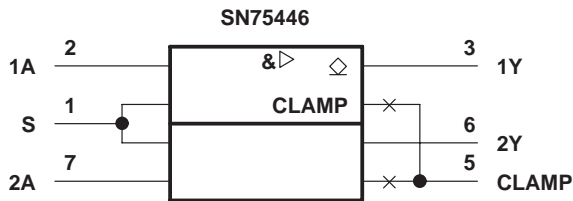

logic diagrams (positive logic)

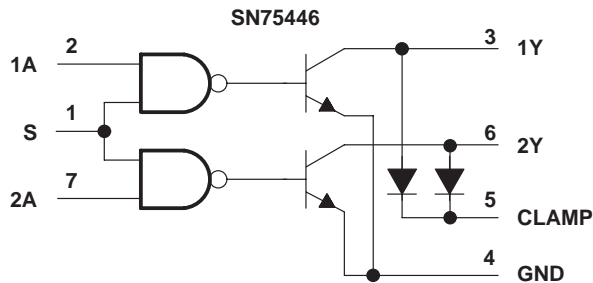

Positive Logic: $Y = \overline{AS}$ or $\overline{A+S}$

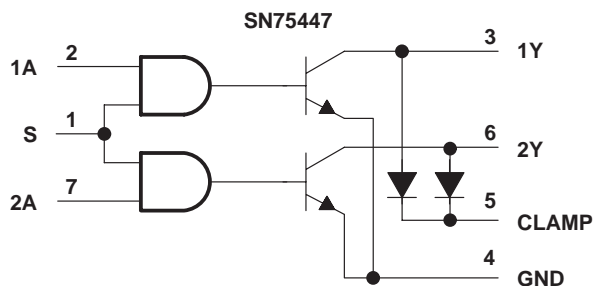

Positive Logic: $Y = \overline{AS}$ or $\overline{A+S}$

† This symbol is in accordance with ANSI/IEEE Std 91-1984 and IEC publication 617-12.

absolute maximum ratings over operating free-air temperature range (unless otherwise noted)‡

Supply voltage, V_{CC} (see Note 1)	7 V
Input voltage, V_I	5.5 V
Output current, I_O (see Note 2)	400 mA
Output clamp-diode current	400 mA
Continuous total power dissipation	See Dissipation Rating Table
Operating free-air temperature range, T_A	0°C to 70°C
Storage temperature range, T_{stg}	-65°C to 150°C
Lead temperature 1,6 mm (1/16 inch) from case for 10 seconds	260°C

‡ Stresses beyond those listed under "absolute maximum ratings" may cause permanent damage to the device. These are stress ratings only, and functional operation of the device at these or any other conditions beyond those indicated under "recommended operating conditions" is not implied. Exposure to absolute-maximum-rated conditions for extended periods may affect device reliability.

- NOTES:
1. Voltage values are with respect to network GND.
 2. Both halves of this dual circuit may conduct rated current simultaneously; however, power dissipation averaged over a short time interval must fall within the continuous dissipation ratings.

DISSIPATION RATING TABLE

PACKAGE	$T_A \leq 25^\circ\text{C}$ POWER RATING	DERATING FACTOR ABOVE $T_A = 25^\circ\text{C}$	$T_A = 70^\circ\text{C}$ POWER RATING
D	725 mW	5.8 mW/°C	464 mW
P	1000 mW	8.0 mW/°C	640 mW

SN75446, SN75447 DUAL PERIPHERAL DRIVERS

SLRS020A – DECEMBER 1978 – REVISED NOVEMBER 1995

recommended operating conditions

	MIN	NOM	MAX	UNIT
Supply voltage, V_{CC}	4.75	5	5.25	V
High-level input voltage, V_{IH}	2			V
Low-level input voltage, V_{IL}			0.8	V
Operating free-air temperature range, T_A	0		70	°C

electrical characteristics over recommended operating free-air temperature range

PARAMETER		TEST CONDITIONS		MIN	TYP†	MAX	UNIT
V_{IK}	Input clamp voltage	$I_I = -12$ mA		-0.9	-1.5		V
V_{OL}	Low-level output voltage	$V_{CC} = 4.75$ V, $V_{IH} = 2$ V, $V_{IL} = 0.8$ V	$I_{OL} = 100$ mA	0.1	0.3		V
			$I_{OL} = 200$ mA	0.22	0.45		
			$I_{OL} = 300$ mA	0.45	0.65		
			$I_{OL} = 350$ mA	0.55	0.75		
$V_{O(BR)}$	Output breakdown voltage	$V_{CC} = 4.75$ V,	$I_{OH} = 100$ μ A	70	100		V
$V_{R(K)}$	Output clamp-diode reverse voltage	$V_{CC} = 4.75$ V,	$I_R = 100$ μ A	70	100		V
$V_{F(K)}$	Output clamp-diode forward voltage	$V_{CC} = 4.75$ V,	$I_F = 350$ mA	0.6	1.2	1.6	V
I_{OH}	High-level output current	$V_{CC} = 4.75$ V, $V_{IL} = 0.8$ V,	$V_{IH} = 2$ V, $V_{OH} = 70$ V		1	100	μ A
I_{IH}	High-level input current	$V_{CC} = 5.25$ V,	$V_I = 5.25$ V		0.01	10	μ A
I_{IL}	Low-level input current	A input	$V_{CC} = 5.25$ V, $V_I = 0.8$ V		-0.5	-10	μ A
		S input			-1	-20	
I_{CCH}	Supply current, outputs high	SN75446	$V_{CC} = 5.25$ V	$V_I = 5$ V	11	18	mA
		SN75447		$V_I = 0$	11	18	
I_{CCL}	Supply current, outputs low	SN75446	$V_{CC} = 5.25$ V	$V_I = 0$	11	18	mA
		SN75447		$V_I = 5$ V	11	18	

† All typical values are at $V_{CC} = 5$ V, $T_A = 25^\circ\text{C}$.

switching characteristics, $V_{CC} = 5$ V, $T_A = 25^\circ\text{C}$

PARAMETER		TEST CONDITIONS		MIN	TYP	MAX	UNIT
t_{PLH}	Propagation delay time, low-to-high-level output	$C_L = 15$ pF, See Figure 1	$R_L = 100$ Ω ,		300	750	ns
t_{PHL}	Propagation delay time, high-to-low-level output				200	500	ns
t_{TLH}	Transition time, low-to-high-level output				50	100	ns
t_{THL}	Transition time, high-to-low-level output				50	100	ns
V_{OH}	High-level output voltage after switching	$V_S = 55$ V, See Figure 2	$I_O \approx 300$ mA,	$V_S - 0.018$			V

SN75446, SN75447 DUAL PERIPHERAL DRIVERS

SLRS020A – DECEMBER 1978 – REVISED NOVEMBER 1995

PARAMETER MEASUREMENT INFORMATION

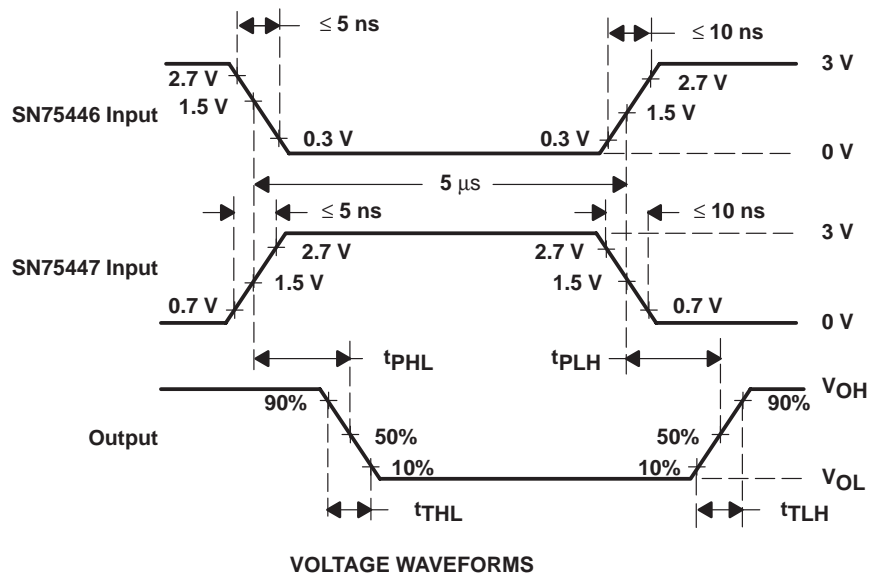
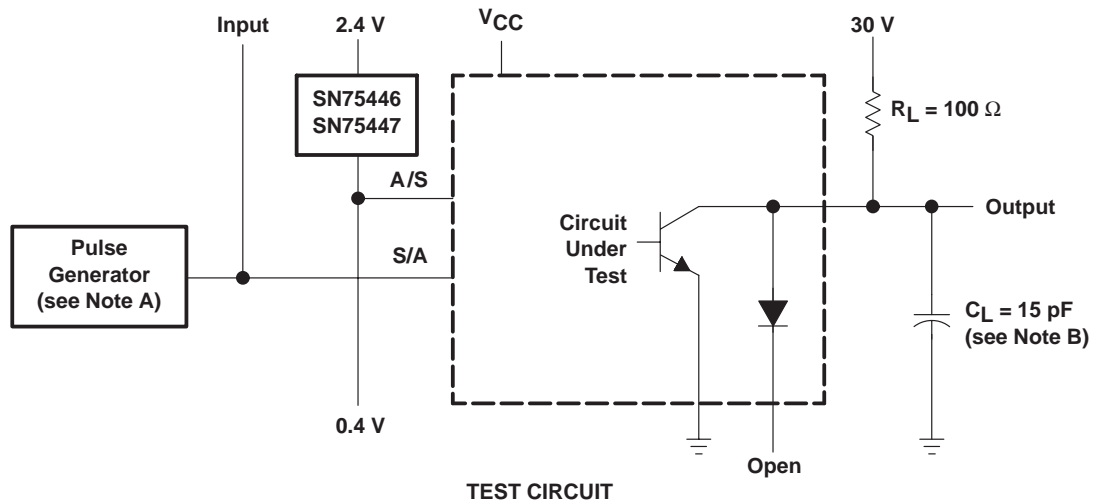

- NOTES: A. The pulse generator has the following characteristics: PRR = 100 kHz, $Z_O = 50 \Omega$.
B. C_L includes probe and jig capacitance.

Figure 1. Test Circuit and Voltage Waveforms, Switching Characteristics

PARAMETER MEASUREMENT INFORMATION

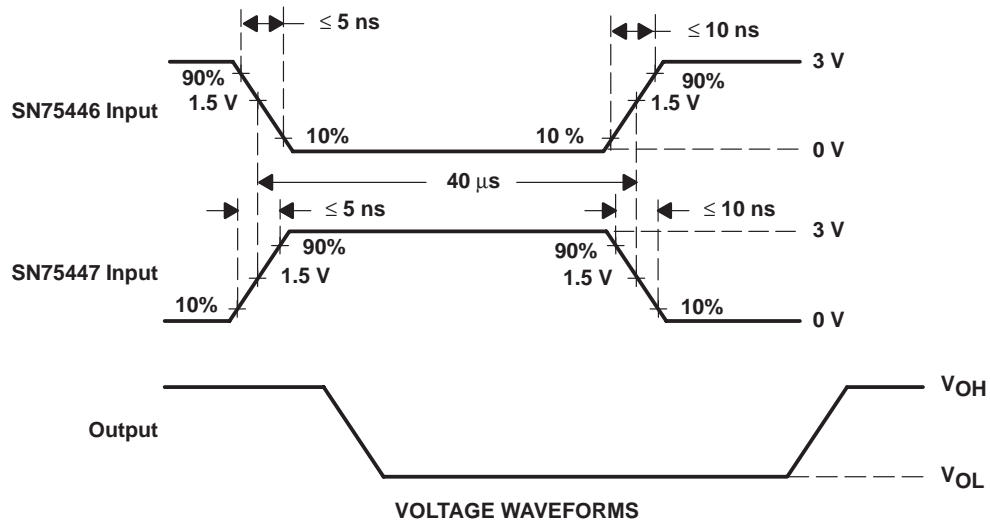
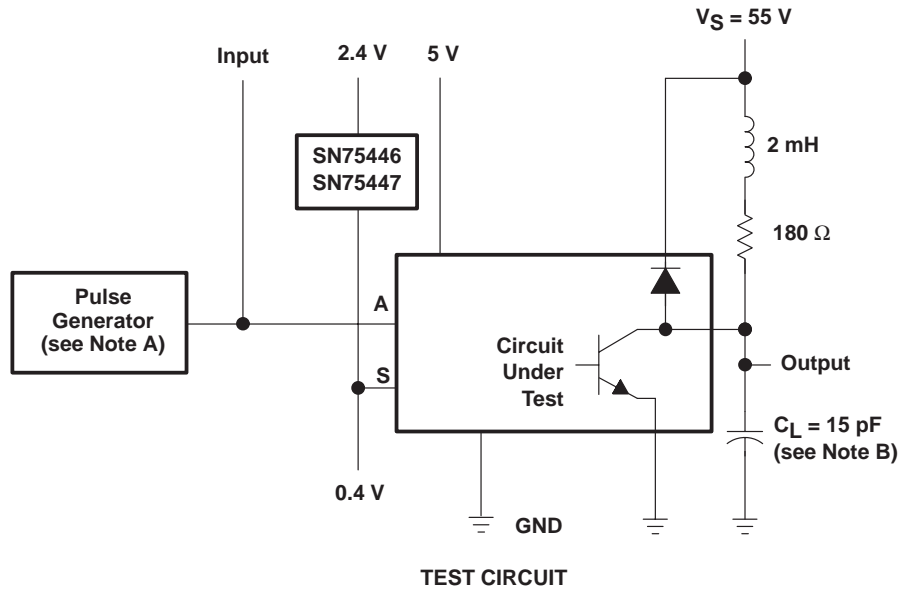

- NOTES: A. The pulse generator has the following characteristics: PRR = 12.5 kHz, $Z_O = 50 \Omega$.
 B. C_L includes probe and jig capacitance.

Figure 2. Latch-Up Test Circuit and Voltage Waveforms

IMPORTANT NOTICE

Texas Instruments and its subsidiaries (TI) reserve the right to make changes to their products or to discontinue any product or service without notice, and advise customers to obtain the latest version of relevant information to verify, before placing orders, that information being relied on is current and complete. All products are sold subject to the terms and conditions of sale supplied at the time of order acknowledgement, including those pertaining to warranty, patent infringement, and limitation of liability.

TI warrants performance of its semiconductor products to the specifications applicable at the time of sale in accordance with TI's standard warranty. Testing and other quality control techniques are utilized to the extent TI deems necessary to support this warranty. Specific testing of all parameters of each device is not necessarily performed, except those mandated by government requirements.

CERTAIN APPLICATIONS USING SEMICONDUCTOR PRODUCTS MAY INVOLVE POTENTIAL RISKS OF DEATH, PERSONAL INJURY, OR SEVERE PROPERTY OR ENVIRONMENTAL DAMAGE ("CRITICAL APPLICATIONS"). TI SEMICONDUCTOR PRODUCTS ARE NOT DESIGNED, AUTHORIZED, OR WARRANTED TO BE SUITABLE FOR USE IN LIFE-SUPPORT DEVICES OR SYSTEMS OR OTHER CRITICAL APPLICATIONS. INCLUSION OF TI PRODUCTS IN SUCH APPLICATIONS IS UNDERSTOOD TO BE FULLY AT THE CUSTOMER'S RISK.

In order to minimize risks associated with the customer's applications, adequate design and operating safeguards must be provided by the customer to minimize inherent or procedural hazards.

TI assumes no liability for applications assistance or customer product design. TI does not warrant or represent that any license, either express or implied, is granted under any patent right, copyright, mask work right, or other intellectual property right of TI covering or relating to any combination, machine, or process in which such semiconductor products or services might be or are used. TI's publication of information regarding any third party's products or services does not constitute TI's approval, warranty or endorsement thereof.