



UCC39151

# 15V Programmable Hot Swap Power Manager

## FEATURES

- Integrated 0.15Ω Power MOSFET
- 7V to 15V Operation
- Digital Programmable Current Limit from 0A to 3A
- Programmable ON Time
- Programmable Start Delay
- Fixed 2% Duty Cycle
- Thermal Shutdown
- Fault Output Indicator
- Maximum Output Current can be set to 1A above the Programmed Fault Level or to a full 4A
- Power SOIC and TSSOP, Low Thermal Resistance Packaging

## DESCRIPTION

The UCC39151 Programmable Hot Swap Power Manager provides complete power management, hot swap capability, and circuit breaker functions. The only external component required to operate the device, other than power supply bypassing, is the fault timing capacitor,  $C_T$ . All control and housekeeping functions are integrated, and externally programmable. These include the fault current level, maximum output sourcing current, maximum fault time, and startup delay. In the event of a constant fault, the Internal fixed 2% duty cycle ratio limits average output power.

The internal 4 bit DAC allows programming of the fault level current from 0A to 3A with 0.25A resolution. The IMAX control pin sets the maximum sourcing current to 1A above the trip level or to a full 4A of output current for fast output capacitor charging.

When the output current is below the fault level, the output MOSFET is switched ON with a nominal ON resistance of 0.15Ω. When the output current exceeds the fault level, but is less than the maximum sourcing level, the output remains switched ON, but the fault timer starts, charging  $C_T$ . Once  $C_T$  charges to a preset threshold, the switch is turned OFF, and remains OFF for 50 times the programmed fault time. When the output current reaches the maximum sourcing level, the MOSFET transitions from a switch to a constant current source.

(continued)

## BLOCK DIAGRAM

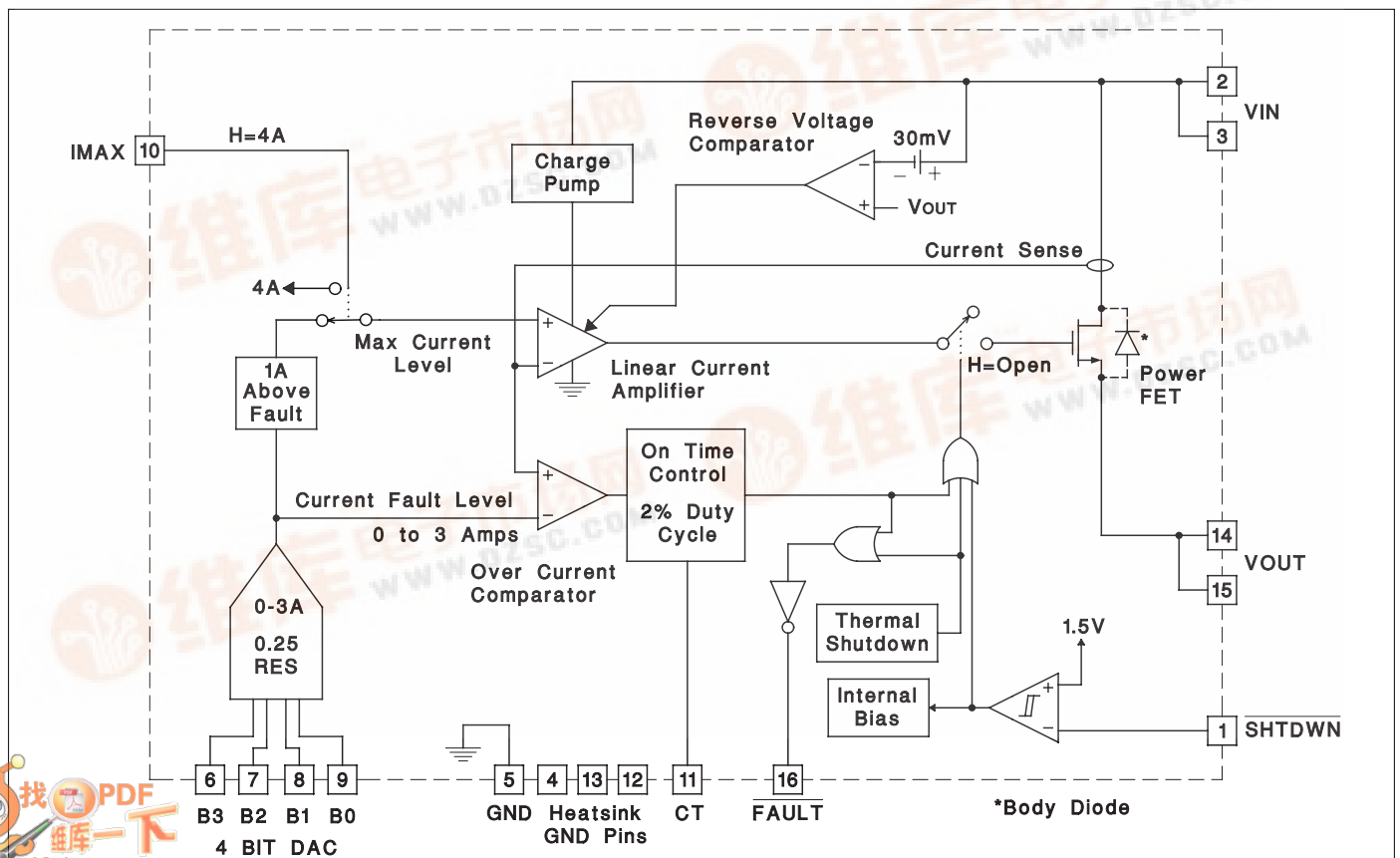

Note: Pin numbers refer to DIL-16 and SOIC-16 packages.

**ABSOLUTE MAXIMUM RATINGS**

V <sub>IN</sub> .....	+15.5 Volts
V <sub>OUT</sub> – V <sub>IN</sub> .....	0.3V
FAULT Sink Current.....	50mA
FAULT Voltage.....	–0.3 to 8V
Output Current.....	Self Limiting
TTL Input Voltage.....	–0.3 to V <sub>IN</sub>
Storage Temperature.....	–65°C to +150°C
Junction Temperature.....	–55°C to +150°C
Lead Temperature (Soldering, 10 sec.).....	+300°C

*Currents are positive into, negative out of the specified terminal. Consult Packaging Section of Databook for thermal limitations and considerations of packages.*

**DESCRIPTION (cont.)**

The UCC39151 can be put into sleep mode, drawing only 20mA of supply current. Other features include an open drain Fault Output Indicator, Thermal Shutdown, Undervoltage Lockout, 7V to 15V operation, and low thermal resistance SOIC and TSSOP Power Packages.

**CONNECTION DIAGRAMS**

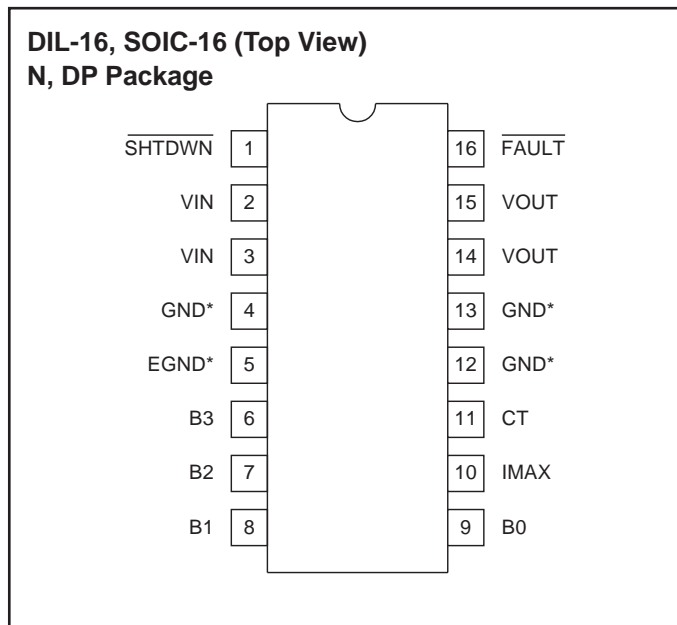

*\*Pin 5 serves as lowest impedance to the electrical ground; Pins 4, 12, and 13 serve as heat sink/ground. These pins should be connected to large etch areas to help dissipate heat. For N Package, pins 4, 12, and 13 are N/C.*

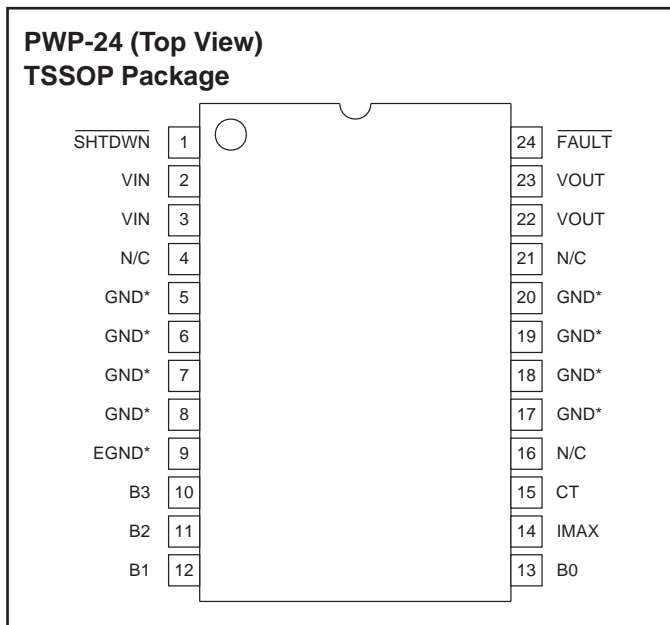

*\*Pin 9 serves as lowest impedance to the electrical ground; other GND pins serve as heat sink/ground. These pins should be connected to large etch areas to help dissipate heat.*

**ELECTRICAL CHARACTERISTICS** Unless otherwise stated, these specifications apply for T<sub>A</sub> = 0°C to 70°C for the UCC39151, V<sub>IN</sub> = 12V, I<sub>MAX</sub> = 0.4V, SHTDWN = 2.4V, T<sub>A</sub> = T<sub>J</sub>.

PARAMETER	TEST CONDITIONS	MIN	TYP	MAX	UNITS
<b>Supply Section</b>					
Voltage Input Range		7.0		15.0	V
Supply Current			1.0	2.0	mA
Sleep Mode Current	SHTDWN = 0.2V, No load		100	150	μA
Output Leakage	SHTDWN = 0.2V			20	mA
<b>Output Section</b>					
Voltage Drop	I <sub>OUT</sub> = 1A (10V to 12V)		0.15	0.3	V
	I <sub>OUT</sub> = 2A (10V to 12V)		0.3	0.6	V
	I <sub>OUT</sub> = 3A (10V to 12V)		0.45	0.9	V
	I <sub>OUT</sub> = 1A, V <sub>IN</sub> = 7V and 15V		0.2	0.4	V
	I <sub>OUT</sub> = 2A, V <sub>IN</sub> = 7V and 15V		0.4	0.8	V
	I <sub>OUT</sub> = 3A, V <sub>IN</sub> = 7V, 12V Max.		0.6	1.2	V

**ELECTRICAL CHARACTERISTICS** Unless otherwise stated, these specifications apply for  $T_A = 0^\circ\text{C}$  to  $70^\circ\text{C}$  for the UCC39151,  $V_{IN} = 12\text{V}$ ,  $I_{MAX} = 0.4\text{V}$ ,  $SHTDWN = 2.4\text{V}$ ,  $T_A = T_J$ .

PARAMETER	TEST CONDITIONS	MIN	TYP	MAX	UNITS
<b>Output Section (continued)</b>					
Initial Startup Time	(Note 2)		100		$\mu\text{s}$
Short Circuit Response	(Note 2)		100		ns
<b>DAC Section</b>					
Trip Current	Code = 0000-0011 (Device Off)				
	Code = 0100	0.07	0.25	0.45	A
	Code = 0101	0.32	0.50	0.7	A
	Code = 0110	0.50	0.75	0.98	A
	Code = 0111	0.75	1.00	1.3	A
	Code = 1000	1.0	1.25	1.6	A
	Code = 1001	1.25	1.50	1.85	A
	Code = 1010	1.5	1.75	2.15	A
	Code = 1011	1.70	2.00	2.4	A
	Code = 1100	1.90	2.25	2.7	A
	Code = 1101	2.1	2.50	2.95	A
	Code = 1110	2.30	2.75	3.25	A
	Code = 1111	2.50	3.0	3.5	A
Max Output Current Over Trip (Current Source Mode)	Code = 0100 to 1111, $I_{MAX} = 0\text{V}$	0.35	1.0	1.65	A
Max Output Current (Current Source Mode)	Code = 0100 to 1111, $I_{MAX} = 2.4\text{V}$	3.0	4.0	5.2	A
<b>Fault Output Section</b>					
CT Charge Current	$V_{CT} = 1.0\text{V}$	-83	-62	-47	$\mu\text{A}$
CT Discharge Current	$V_{CT} = 1.0\text{V}$	0.8	1.2	1.8	$\mu\text{A}$
Output Duty Cycle	$V_{OUT} = 0\text{V}$	1.0	1.9	3.3	%
CT Fault Threshold		1.2	1.5	1.7	V
CT Reset Threshold		0.4	0.5	0.6	V
<b>Shutdown Section</b>					
Shutdown Threshold		1.1	1.5	1.9	V
Shutdown Hysteresis			150		mV
Input Current			100	500	nA
<b>Open Drain Output Section</b>					
High Level Output Current	$\overline{\text{FAULT}} = 5\text{V}$			250	$\mu\text{A}$
Low Level Output Voltage	$I_{OUT} = 5\text{mA}$		0.2	0.8	V
<b>TTL Input DC Characteristics Section</b>					
TTL Input Voltage High		2.0			V
TTL Input Voltage Low				0.8	V
TTL Input High Current	$V_{IH} = 2.4\text{V}$		3	10	$\mu\text{A}$
TTL Input Low Current	$V_{IL} = 0.4\text{V}$			1	$\mu\text{A}$

Note 1: All voltages are with respect to Ground. Current is positive into and negative out of the specified terminal.

Note 2: Guaranteed by design. Not 100% tested in production.

**PIN DESCRIPTIONS**

**B0, B1, B2, B3:** These pins provide digital input to the DAC, which sets the fault current threshold. They can be used to provide a digital soft-start and adaptive current limiting.

**CT:** A capacitor connected to ground sets the maximum fault time. The maximum fault time must be more than the time required to charge the external capacitance in one cycle. The maximum fault time is defined as:

$$T_{FAULT} = 16.1 \cdot 10^3 \cdot C_T$$

Once the fault time is reached the output will shutdown for a time given by:

$$T_{SD} = 833 \cdot 10^3 \cdot C_T$$

this equates to a 1.9% duty cycle.

**FAULT:** Open drain output, which pulls low upon any fault or interrupt condition, Fault, or Thermal Shutdown.

**IMAX:** When this pin is set to a logic low, the maximum sourcing current will always be 1A above the programmed fault level. When set to a logic high, the maximum sourcing current will be a constant 4A for applications which require fast charging of load capacitance.

**SHTDWN:** When this pin is brought to a logic low, the IC is put into a sleep mode drawing typically less than 100µA of I<sub>CC</sub> (with V<sub>OUT</sub> unloaded). The input threshold is hysteretic, allowing the user to program a startup delay with an external RC circuit.

**VIN:** Input voltage to the UCC39151. The recommended voltage range is 7V to 15V. Both VIN pins should be connected together and connected to power source.

**VOUT:** Output voltage from the UCC39151. Both VOUT pins should be connected together and connected to the load. When switched:

$$V_{OUT} \approx V_{IN} - (0.15\Omega \cdot I_{OUT})$$

V<sub>OUT</sub> must not exceed V<sub>IN</sub> by more than 0.3V.

**APPLICATIONS INFORMATION**

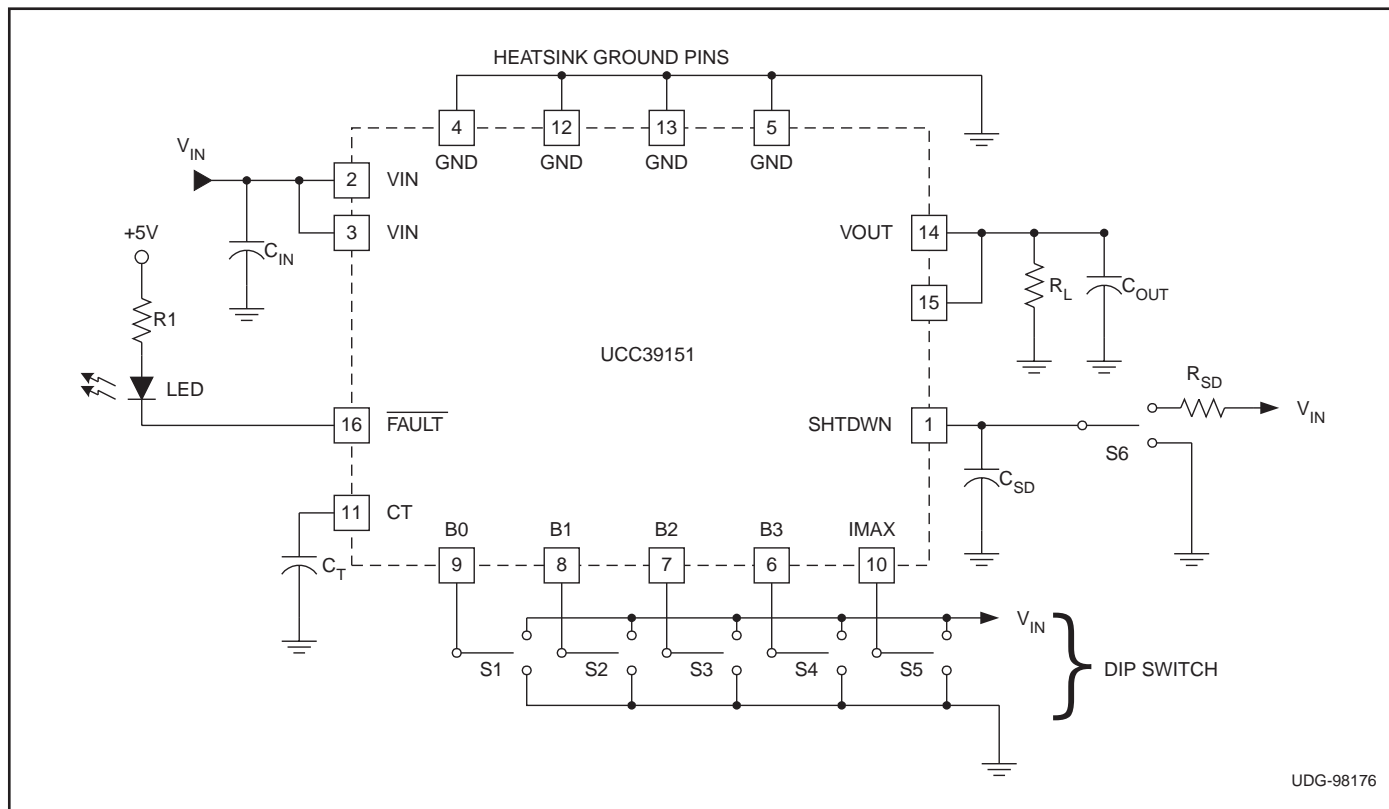

UDG-98176

Figure 1. Evaluation circuit.

APPLICATION INFORMATION (cont.)

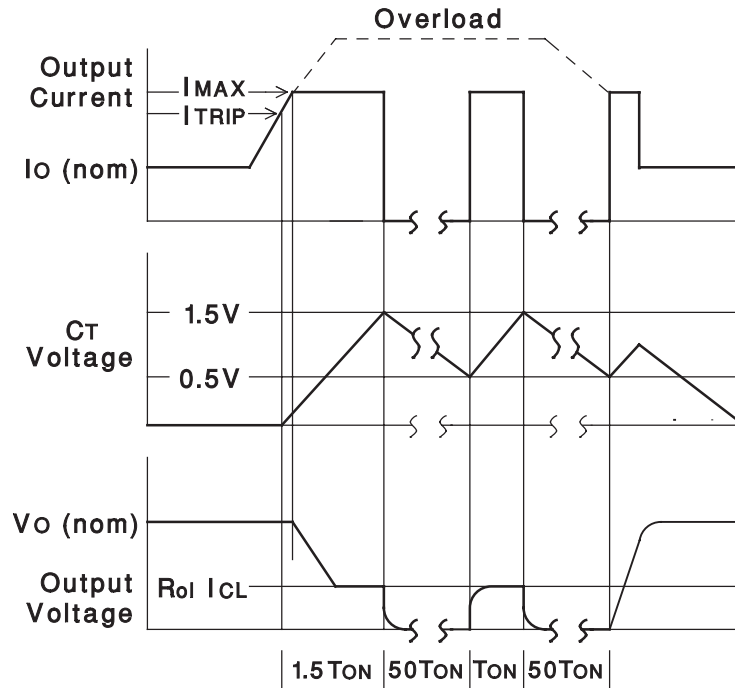

UDG-94138

**Estimating Maximum Load Capacitance**

For hot swap applications, the rate at which the total output capacitance can be charged depends on the maximum output current available and the nature of the load. For a constant-current, current-limited application, the output will come up if the load asks for less than the maximum available short-circuit current.

To guarantee recovery of a duty-cycle from a short-circuited load condition, there is a maximum total output capacitance which can be charged for a given unit ON time (Fault time). The design value of ON or Fault time can be adjusted by changing the timing capacitor  $C_T$ .

For worst-case constant-current load of value just less than the trip limit;  $C_{OUT(max)}$  can be estimated from:

$$C_{OUT(max)} \approx (I_{MAX} - I_{LOAD}) \cdot \left( \frac{16.1 \cdot 10^3 \cdot C_T}{V_{OUT}} \right)$$

Where  $V_{OUT}$  is the output voltage.

For a resistive load of value  $R_L$ , the value of  $C_{OUT(max)}$  can be estimated from:

$$C_{OUT(max)} \approx \left( \frac{16.1 \cdot 10^3 \cdot C_T}{R_L \cdot \ln \left[ \frac{1}{1 - \frac{V_{OUT}}{I_{MAX} \cdot R_L}} \right]} \right)$$

Long  $C_T$  times must consider the maximum temperature. Thermal shutdown protection may be the limiting Fault time.

Figure 2. Load current, timing capacitor voltage, and output voltage of the UCC39151 under fault conditions.

**SAFETY RECOMMENDATIONS**

Although the UCC39151 is designed to provide system protection for all fault conditions, all integrated circuits can ultimately fail short. For this reason, if the UCC39151 is intended for use in safety critical applications where UL or some other safety rating is required, a redundant safety device such as a fuse should be placed

in series with the device. The UCC39151 will prevent the fuse from blowing for virtually all fault conditions, increasing system reliability and reducing maintenance cost, in addition to providing the hot swap benefits of the device.

## **IMPORTANT NOTICE**

Texas Instruments and its subsidiaries (TI) reserve the right to make changes to their products or to discontinue any product or service without notice, and advise customers to obtain the latest version of relevant information to verify, before placing orders, that information being relied on is current and complete. All products are sold subject to the terms and conditions of sale supplied at the time of order acknowledgement, including those pertaining to warranty, patent infringement, and limitation of liability.

TI warrants performance of its semiconductor products to the specifications applicable at the time of sale in accordance with TI's standard warranty. Testing and other quality control techniques are utilized to the extent TI deems necessary to support this warranty. Specific testing of all parameters of each device is not necessarily performed, except those mandated by government requirements.

**CERTAIN APPLICATIONS USING SEMICONDUCTOR PRODUCTS MAY INVOLVE POTENTIAL RISKS OF DEATH, PERSONAL INJURY, OR SEVERE PROPERTY OR ENVIRONMENTAL DAMAGE ("CRITICAL APPLICATIONS"). TI SEMICONDUCTOR PRODUCTS ARE NOT DESIGNED, AUTHORIZED, OR WARRANTED TO BE SUITABLE FOR USE IN LIFE-SUPPORT DEVICES OR SYSTEMS OR OTHER CRITICAL APPLICATIONS. INCLUSION OF TI PRODUCTS IN SUCH APPLICATIONS IS UNDERSTOOD TO BE FULLY AT THE CUSTOMER'S RISK.**

In order to minimize risks associated with the customer's applications, adequate design and operating safeguards must be provided by the customer to minimize inherent or procedural hazards.

TI assumes no liability for applications assistance or customer product design. TI does not warrant or represent that any license, either express or implied, is granted under any patent right, copyright, mask work right, or other intellectual property right of TI covering or relating to any combination, machine, or process in which such semiconductor products or services might be or are used. TI's publication of information regarding any third party's products or services does not constitute TI's approval, warranty or endorsement thereof.