



# Multimode SCSI 15 Line Terminator with Reverse Disconnect

## FEATURES

- Auto Selection Single Ended (SE) or Low Voltage Differential (LVD) Termination
- Meets SCSI-1, SCSI-2, SCSI-3, SPI, Ultra (Fast-20), Ultra2 (SPI-2 LVD) and Ultra3 Standards
- 2.7V to 5.25V Operation
- Differential Failsafe Bias
- Thermal packaging for low junction temperature and better MTBF.

## DESCRIPTION

The UCC5639 Multimode SCSI Terminator provides a smooth transition into the next generation of the SCSI Parallel Interface (SPI-2). It automatically senses the bus, via DIFFB, and switches the termination to either single ended (SE) or low voltage differential (LVD) SCSI, dependent on which type of devices are connected to the bus. The UCC5639 can not be used on a HVD, EIA485, differential SCSI bus. If the UCC5639 detects a HVD SCSI device, it switches to a high impedance state.

The Multimode terminator contains all functions required to terminate and auto detect and switch modes for SPI-2 bus architectures. Single Ended and Differential impedances and currents are trimmed for maximum effectiveness. Fail Safe biasing is provided to insure signal integrity. Device/Bus type detection circuitry is integrated into the terminator to provide automatic switching of termination between single ended and LVD SCSI and a high impedance for HVD SCSI. The multimode function provides all the performance analog functions necessary to implement SPI-2 termination in a single monolithic device.

The UCC5639 is offered in a 48 pin LQFP package for a temperature range of 0°C to 70°C.

## BLOCK DIAGRAM

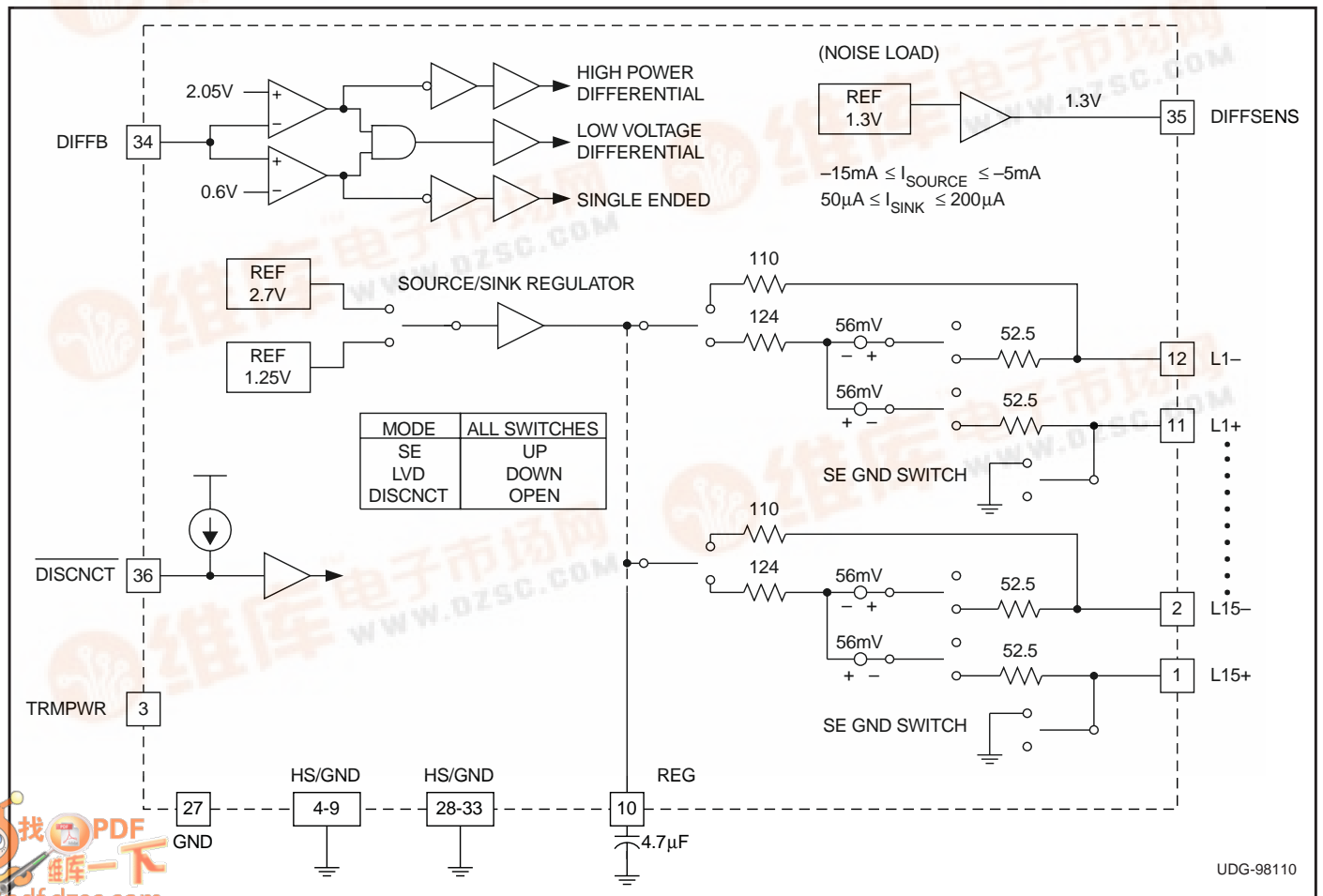

**ABSOLUTE MAXIMUM RATINGS**

TRMPWR Voltage	+6V
Signal Line Voltage	0V to TRMPWR
Package Dissipation	2W
Storage Temperature	-65°C to +150°C
Junction Temperature	-55°C to +150°C
Lead Temperature (Soldering, 10 sec.)	+300°C
Recommended Operating Conditions	2.7V to 5.25V

Currents are positive into negative out of the specified terminal.  
 Note: Consult Packaging Section of Databook for thermal limitations and considerations of package.

**RECOMMENDED OPERATING CONDITIONS**

TRMPWR Voltage	2.7V to 5.25V
Temperature Ranges	0°C to +70°C

**CONNECTION DIAGRAMS**

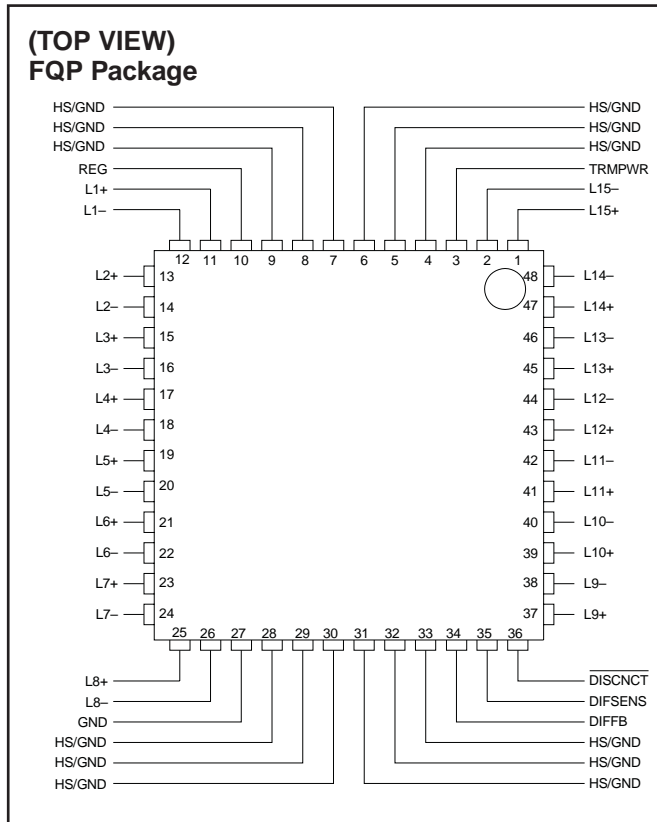

**ELECTRICAL CHARACTERISTICS** Unless otherwise stated, these specifications apply for  $T_A = T_J = 0^\circ\text{C}$  to  $70^\circ\text{C}$ , TRMPWR = 3.3V.

PARAMETER	TEST CONDITIONS	MIN	TYP	MAX	UNITS
<b>TRMPWR Supply Current Section</b>					
TRMPWR Supply Current	LVD Mode		20	25	mA
	SE Mode		1.6	10	mA
	Disabled Terminator		250	400	$\mu\text{A}$
<b>Regulator Section</b>					
1.25V Regulator	LVD Mode	1.15	1.25	1.35	V
1.25V Regulator Source Current	$V_{\text{REG}} = 0\text{V}$	-375	-700	-1000	mA
1.25V Regulator Sink Current	$V_{\text{REG}} = 3.3\text{V}$	170	300	700	mA
1.3V Regulator	DIFSENS	1.2	1.3	1.4	V
1.3V Regulator Source Current	$V_{\text{REG}} = 0\text{V}$	-15		-5	mA
1.3V Regulator Sink Current	$V_{\text{REG}} = 3.3\text{V}$	50		200	$\mu\text{A}$
2.7V Regulator	SE Mode	2.5	2.7	3.0	V
2.7V Regulator Source Current	$V_{\text{REG}} = 0\text{V}$	-375	-700	-1000	mA
2.7V Regulator Sink Current	$V_{\text{REG}} = 3.3\text{V}$	170	300	700	mA
<b>Differential Termination Section</b>					
Differential Impedance		100	105	110	$\Omega$
Common Mode Impedance	(Note 2)	110	150	165	$\Omega$
Differential Bias Voltage		100		125	mV
Common Mode Bias		1.15	1.25	1.35	V
Output Capacitance	Single Ended Measurement to Ground (Note 1)			3	pF

**ELECTRICAL CHARACTERISTICS** Unless otherwise stated, these specifications apply for T<sub>A</sub> = T<sub>J</sub> = 0°C to 70°C, TRMPWR = 3.3V.

PARAMETER	TEST CONDITIONS	MIN	TYP	MAX	UNITS
<b>Single Ended Termination Section</b>					
Impedance	$Z = (V_{LX} - 0.2V) / I_{LX}$ , (Note 3)	102.3	110	117.7	Ω
Termination Current	Signal Level 0.2V, All Lines Low	-21	-24	-25.4	mA
	Signal Level 0.5V	-18		-22.4	mA
Output Leakage				400	nA
Output Capacitance	Single Ended Measurement to Ground (Note 1)			3	pF
Single Ended GND SE Impedance	I = 10mA		20	60	Ω
<b>Disconnect and Diff Buffer Input Section</b>					
DISCNCT Threshold		0.8		2.0	V
DISCNCT Input Current			10	30	μA
Diff Buffer Single Ended to LVD Threshold		0.5		0.7	V
Diff Buffer LVD to HPD Threshold		1.9		2.2	V
DIFFB Input Current		-10		10	μA

**Note 1:** Guaranteed by design. Not 100% tested in production.

**Note 2:**  $Z_{CM} = \frac{1.2V}{[I_{(VCM+0.6V)} - I_{(VCM-0.6V)}]}$  where VCM=voltage measured with L+ tied to L- and zero current applied

**Note 3:** V<sub>LX</sub>= Output voltage for each terminator minus output pin (L1- through L15-) with each pin unloaded.  
 I<sub>LX</sub> = Output current for each terminator minus output pin (L1- through L15-) with the minus output pin forced to 0.2V.

**PIN DESCRIPTIONS**

**DIFFB:** Diff sense filter pin should be connected at a 0.1μF capacitor.

**DIFSENS:** The SCSI bus Diff Sense line to detect what types of devices are connected to the SCSI bus.

**DISCNCT:** Disconnect pin shuts down the terminator when it is not at the end of the bus. The disconnect pin high enables the terminator.

**LINE<sub>n-</sub>:** Signal line active line for single ended or negative line in differential applications for the SCSI bus.

**LINE<sub>n+</sub>:** Ground line for single ended or positive line for differential applications for the SCSI bus.

**REG:** Regulator bypass pin, must be connected to a 4.7μF capacitor.

**TRMPWR:** V<sub>IN</sub> 2.7V to 5.25V supply.

## APPLICATION INFORMATION

The UCC5639 is a Multi-mode active terminator with selectable single ended (SE) and low voltage differential (LVD) SCSI termination integrated into a monolithic component. Mode selection is accomplished with the "diff sense" signal.

The diff sense signal is a three level signal, which is driven at each end of the bus by one active terminator. A LVD or multi-mode terminator drives the diff sense line to 1.3 V. If diff sense is at 1.3 V, then bus is in LVD mode. If a single ended SCSI device is plugged into the bus, the diff sense line is shorted to ground. With diff sense shorted to ground, the terminator changes to single ended mode to accommodate the SE device. If a HVD device is plugged in to the bus, the diff sense line is pulled high and the terminator shuts down.

The diff sense line is driven and monitored by the terminator through a 50Hz noise filter at the DIFFB input pin. A set of comparators, that allow for ground shifts, determine the bus status as follows. Any diff sense signal below 0.5V is single ended, between 0.7V and 1.9V is LVD and above 2.2V is HVD.

In the single ended mode, a multi-mode terminator has a 110 $\Omega$  terminating resistor connected to a 2.7V termination voltage regulator. The 2.7V regulator is used on all Unitorde terminators designed for 3.3V systems. This requires the terminator to operate in specification down to 2.7V TRMPWR voltage to allow for the 3.3V supply tolerance, an unidirectional fusing device and cable drop. At each L+ pin, a ground driver drives the pin to ground, while in single ended mode. The ground driver is specially designed so it will not effect the capacitive balance of the bus when the device is in LVD or disconnect mode. The device requirements call for 0.5pF balance on the lines of a differential pair. The terminator capacitance has to be a small part of the capacitance imbalance.

Layout is very critical for Ultra2 and Ultra3 systems. Multi-layer boards need to adhere to the 120 $\Omega$  impedance standard, including connector and feed-through. This is normally done on the outer layers with 4 mil etch

and 4 mil spacing between the runs within a pair, and a minimum of 8 mil spacing to the next pair. This spacing between the pairs reduces potential crosstalk. Beware of feed-throughs and each through hole connection adds a lot of capacitance. Standard power and ground plane spacing yields about 1pF to each plane. Each feed-through will add about 2.5pF to 3.5pF. Enlarging the clearance holes on both power and ground planes can reduce the capacitance and opening up the power and ground planes under the connector can reduce the capacitance for through hole connector applications. Microstrip technology is normally too low of impedance and should not be used. It is designed for 50 $\Omega$  rather than 120 $\Omega$  differential systems.

Capacitance balance is critical for Ultra2 and Ultra3. The balance capacitance standard is 0.5pF per line with the balance between pairs of 2pF. The components are designed with very tight balance, typically 0.1pF between pins in a pair and 0.3pF between pairs. Layout balance is critical, feed-throughs and etch length must be balanced, preferably no feed-throughs would be used. Capacitance for devices should be measured in the typical application, material and components above and below the circuit board effect the capacitance.

Multi-mode terminators need to consider power dissipation; the UCC5639 is offered in a power package with heat sink ground pins. These heat sink/ground pins are directly connected to the die mount paddle under the die and conduct heat from the die to reduce the junction temperature. These pins need to be connected to etch area or a feed-through per pin connecting to the ground plane layer on a multi-layer board.

In 3.3V TRMPWR systems, the UCC3912 should be used to replace the fuse and diode. This reduces the voltage drop, allowing for cable drop to the far end terminator. 3.3V battery systems normally have a 10% tolerance. The UCC3912 is 150mV drop under LVD loads, allowing 150mV drop in the cable system. All Unitorde LVD and multi-mode terminators are designed for 3.3V systems, operating down to 2.7V.

TYPICAL APPLICATION

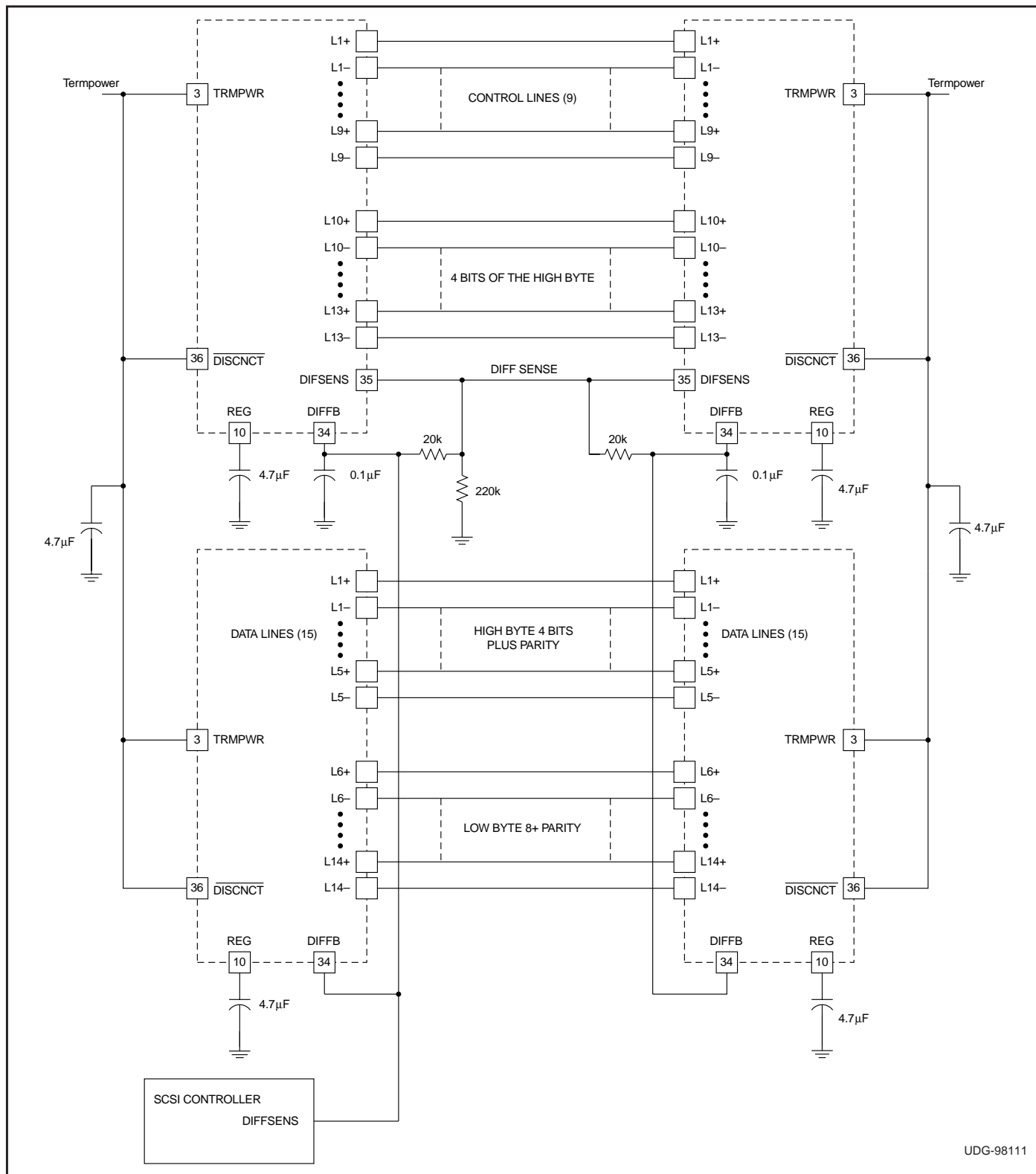

**Note:** A 220k resistor is added to ground to insure the transceivers will come up in single-ended mode when no terminator is enabled. The controller DIFSENS ties to the DIFFFB pin on the terminators, only one RC network should be on a device.

## **IMPORTANT NOTICE**

Texas Instruments and its subsidiaries (TI) reserve the right to make changes to their products or to discontinue any product or service without notice, and advise customers to obtain the latest version of relevant information to verify, before placing orders, that information being relied on is current and complete. All products are sold subject to the terms and conditions of sale supplied at the time of order acknowledgement, including those pertaining to warranty, patent infringement, and limitation of liability.

TI warrants performance of its semiconductor products to the specifications applicable at the time of sale in accordance with TI's standard warranty. Testing and other quality control techniques are utilized to the extent TI deems necessary to support this warranty. Specific testing of all parameters of each device is not necessarily performed, except those mandated by government requirements.

**CERTAIN APPLICATIONS USING SEMICONDUCTOR PRODUCTS MAY INVOLVE POTENTIAL RISKS OF DEATH, PERSONAL INJURY, OR SEVERE PROPERTY OR ENVIRONMENTAL DAMAGE ("CRITICAL APPLICATIONS"). TI SEMICONDUCTOR PRODUCTS ARE NOT DESIGNED, AUTHORIZED, OR WARRANTED TO BE SUITABLE FOR USE IN LIFE-SUPPORT DEVICES OR SYSTEMS OR OTHER CRITICAL APPLICATIONS. INCLUSION OF TI PRODUCTS IN SUCH APPLICATIONS IS UNDERSTOOD TO BE FULLY AT THE CUSTOMER'S RISK.**

In order to minimize risks associated with the customer's applications, adequate design and operating safeguards must be provided by the customer to minimize inherent or procedural hazards.

TI assumes no liability for applications assistance or customer product design. TI does not warrant or represent that any license, either express or implied, is granted under any patent right, copyright, mask work right, or other intellectual property right of TI covering or relating to any combination, machine, or process in which such semiconductor products or services might be or are used. TI's publication of information regarding any third party's products or services does not constitute TI's approval, warranty or endorsement thereof.