



# Low Voltage Differential (LVD/SE) SCSI 9 Line Terminator

## FEATURES

- Auto Selection Multi-Mode Single Ended or Low Voltage Differential Termination
- 3.0V to 5.25V Operation
- Differential Failsafe Bias
- Thermal Packaging for Low Junction Temperature and Better MTBF
- Master/Slave Inputs
- Supports Active Negation
- 3pF Channel Capacitance

## DESCRIPTION

The UCC5510 Multi-Mode Low Voltage Differential and Single Ended Terminator is specially designed for automatic termination of Single-Ended or Low Voltage Differential SCSI Bus. The Multi-Mode operation of this device allows for a transition system design for the next generation SCSI Parallel Interface (SPI-2). Compliant with SPI-2, with SPI and Fast-20 the UCC5510 incorporates all the functions necessary to properly terminate the SCSI Bus and has internal thermal shut down and short circuit limiting.

## BLOCK DIAGRAM

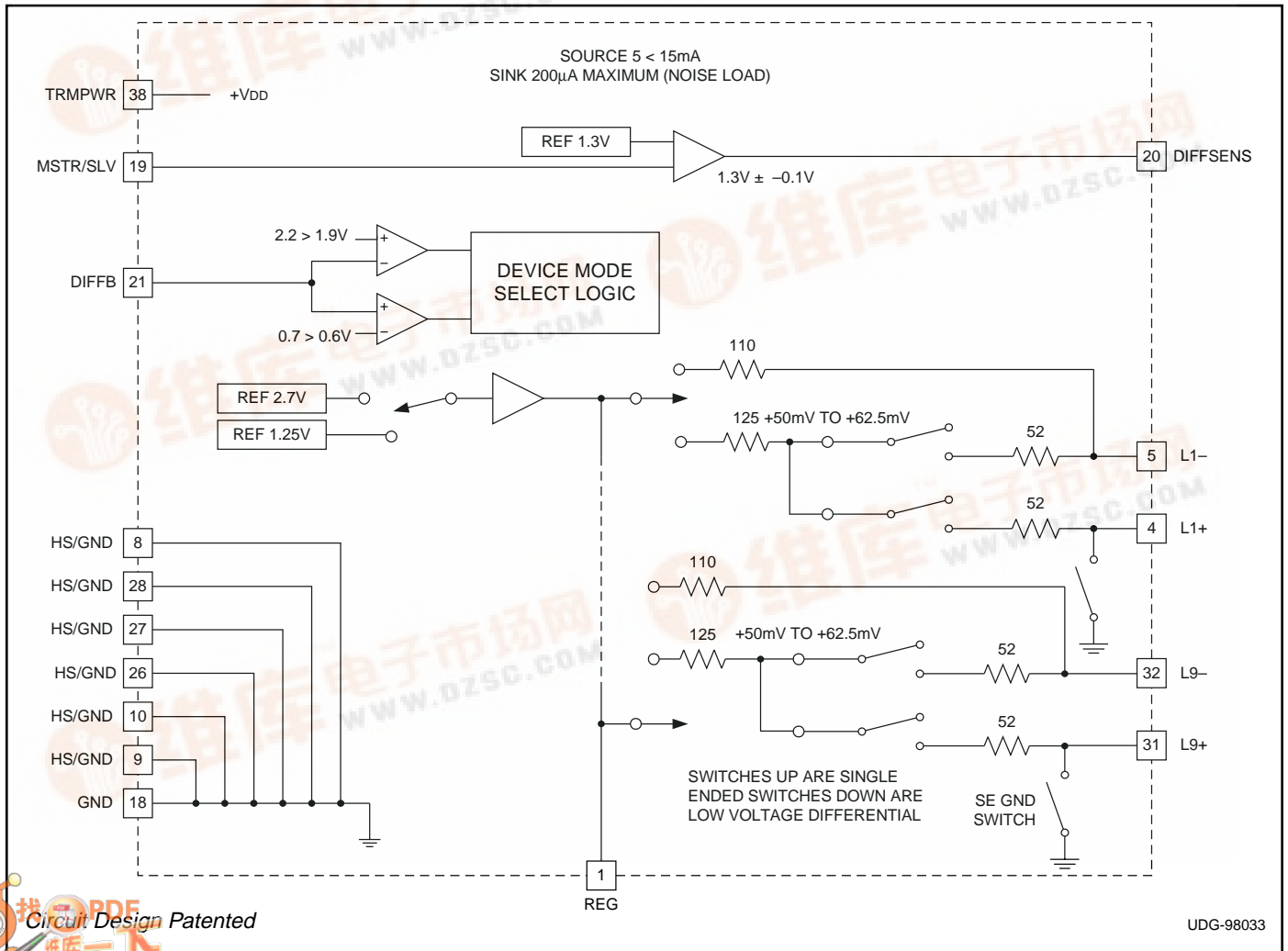

**ABSOLUTE MAXIMUM RATINGS**

TRMPWR Voltage	6V
Signal Line Voltage	0V to TRMPWR
Package Power Dissipation	2W
Storage Temperature	-65°C to +150°C
Junction Temperature	-55°C to +150°C
Lead Temperature (Soldering, 10sec.)	+300°C

**RECOMMENDED OPERATING CONDITIONS**

TRMPWR Voltage	3.0V TO 5.25V
----------------	---------------

All voltages are with respect to pin 1. Currents are positive into, negative out of the specified terminal. Consult Packaging Section of the Databook for thermal limitations and considerations of packages.

**CONNECTION DIAGRAM**

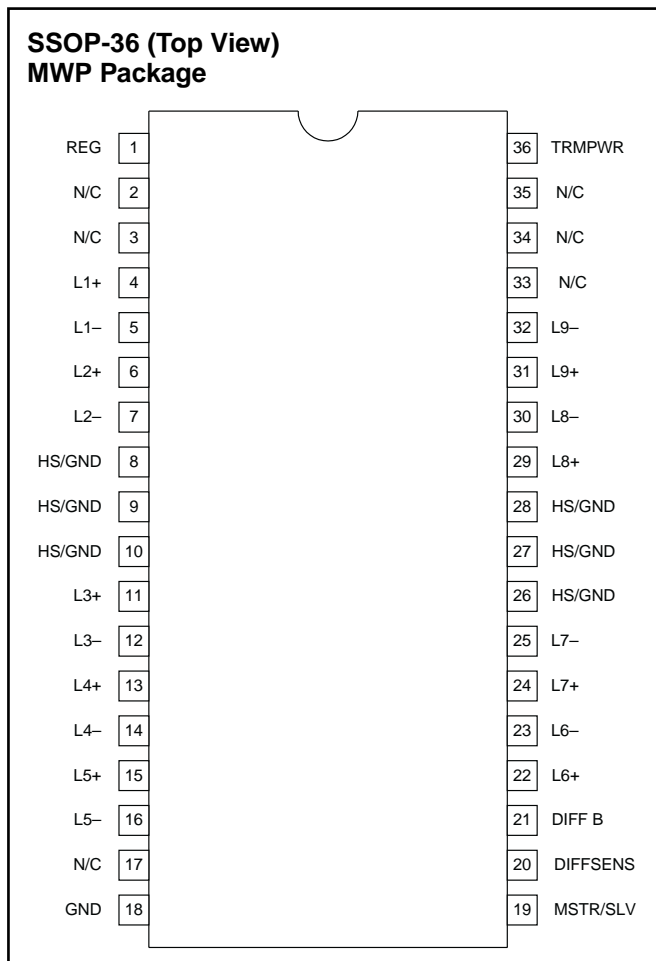

**ELECTRICAL CHARACTERISTICS:** Unless otherwise specified, TA = 0°C to 70°C, TRMPWR = 3.3V.

PARAMETER	TEST CONDITIONS	MIN	TYP	MAX	UNITS
<b>TRMPWR Supply Current Section</b>					
TRMPWR Supply Current				20	mA
	Disable Terminator, in DISCNCT mode.			35	µA
<b>Regulator Section</b>					
1.25V Regulator	LVD Mode	1.15	1.25	1.35	V
1.25V Regulator Source Current	LVD Mode, Differential Sense Floating	-80	-100		mA
1.25V Regulator Sink Current	LVD Mode, Differential Sense Floating	80	100		mA
1.3V Regulator	DIFFSENS	1.2	1.3	1.4	V
1.3V Regulator Source Current	DIFFSENS	-5		-15	mA
1.3V Regulator Sink Current	DIFFSENS	50		200	µA
2.7V Regulator	Single Ended Mode	2.5	2.7	3	V
2.7V Regulator Source Current	Single Ended Mode	-200	-400	-800	mA
2.7V Regulator Sink Current	Single Ended Mode	100	200	400	mA
2.7V Regulator Dropout Voltage	V <sub>TRMPWR</sub> - (V <sub>REG</sub> - 3.0 Min)			200	mV

**ELECTRICAL CHARACTERISTICS:** Unless otherwise specified, TA = 0°C to 70°C, TRMPWR = 3.3V.

PARAMETER	TEST CONDITIONS	MIN	TYP	MAX	UNITS
<b>Differential Termination Section</b>					
Differential Impedance		100	105	110	Ω
Common Mode Impedance		110	125	165	Ω
Differential Bias Voltage	Drivers Tri-stated	100		125	mV
Common Mode Bias			1.25		V
Output Capacitance	Single Ended Measurement to Ground (Note 1)			3	pF
<b>Single Ended Termination Section</b>					
Impedance		102.3	110	117.7	Ω
Termination Current	Signal Level 0.2V	-21	-23	-24	mA
	Signal Level 0.5V			-22.4	mA
Output Leakage	Disabled, TRMPWR = 0V to 5.25V			400	nA
Output Capacitance	Single Ended Measurement to Ground (Note 1)			3	pF
Single Ended GND SW Impedance				60	Ω
<b>Differential Sense (DIFF B) Input Sections</b>					
DIFFB Single Ended Threshold		0.6		0.7	V
DIFFB Sense LVD Threshold		1.9		2.2	V
DIFFB Input Current	V <sub>DIFFB</sub> = 0V and 3.3V	-10		10	μA
<b>Master/Slave (MSTR/SLV) Input Section</b>					
MSTR/SLV Threshold		0.8		2	V
MSTR/SLV Input Current		-30		30	μA

Note 1: Guaranteed by design. Not 100% tested in production.

## PIN DESCRIPTIONS

**DIFFB:** DIFF SENSE filter pin should be connected to a 0.1μF capacitor to GND and 20k resistor to SCSI/Bus DIFF SENSE Line.

**DIFFSENS:** The SCSI bus DIFF SENSE line is driven to 1.3V to detect what type of devices are connected to the SCSI bus.

**HS/GND:** Heat Sink GND. Connect to large area PC board traces to increase power dissipation capability.

**GND:** Power Supply Return.

**L1– thru L9–:** Signal line/active line for single ended or

negative line in differential applications for the SCSI bus.

**L1+ thru L9+:** Ground line for single ended or positive line for differential applications for the SCSI bus.

**MSTR/SLV:** Mode select for the non-controlling terminator. MSTR enables the 1.3V regulator, when the terminator is enabled. **Note:** This function will be removed on further generations of the multimode terminators.

**REG:** Regulator bypass, must be connected to a 4.7μF capacitor.

**TRMPWR:** V<sub>IN</sub> 3.0V to 5.25V supply.

APPLICATION INFORMATION

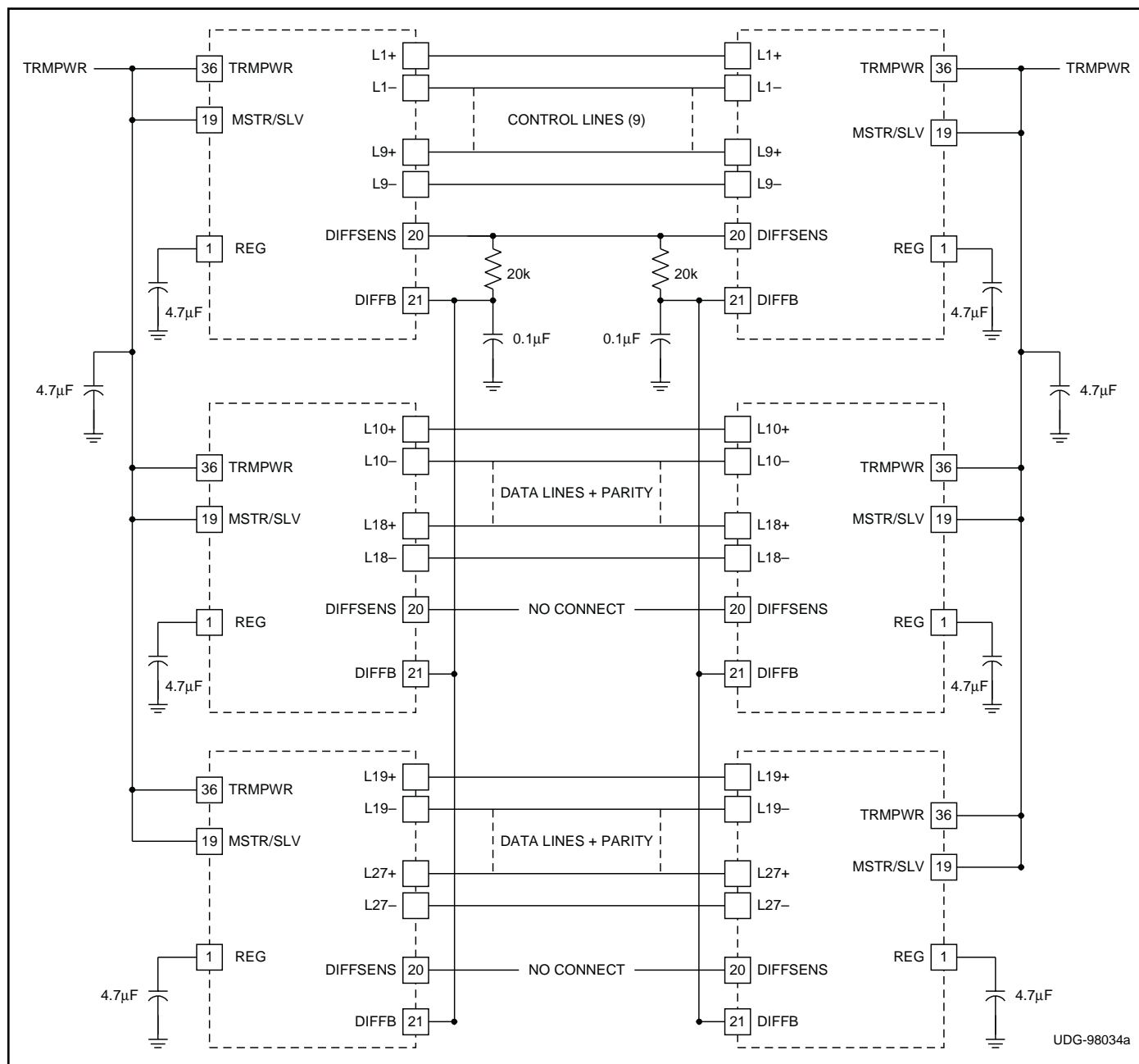

Figure 1. Application Drawing

The master is selected by placing TRMPWR on MSTR/SLV and enabling the 1.3V regulator. The master is the only terminator connected directly to the DIFFSENS bus line. All the other terminators receive a mode signal by connecting the DIFFFB pins together.

The balancing capacitor is very important during high speed operation. The typical capacitor balance between the positive (+) and negative (-) signals is 0.1pF, except

in the MWP package where between L8 and L9 the balance is 0.23pF and 0.4pF respectively. The negative (-) signal line has a higher capacitance than the positive (+) signal line. The FQP package has typically 0.2pF less capacitance than the MWP package, where the typical balance is 0.1pF except for L8 and L3, where the balance is 0.4pF.

*Note: The master/slave function will not be included in future Unitorde terminators.*

## **IMPORTANT NOTICE**

Texas Instruments and its subsidiaries (TI) reserve the right to make changes to their products or to discontinue any product or service without notice, and advise customers to obtain the latest version of relevant information to verify, before placing orders, that information being relied on is current and complete. All products are sold subject to the terms and conditions of sale supplied at the time of order acknowledgment, including those pertaining to warranty, patent infringement, and limitation of liability.

TI warrants performance of its semiconductor products to the specifications applicable at the time of sale in accordance with TI's standard warranty. Testing and other quality control techniques are utilized to the extent TI deems necessary to support this warranty. Specific testing of all parameters of each device is not necessarily performed, except those mandated by government requirements.

Customers are responsible for their applications using TI components.

In order to minimize risks associated with the customer's applications, adequate design and operating safeguards must be provided by the customer to minimize inherent or procedural hazards.

TI assumes no liability for applications assistance or customer product design. TI does not warrant or represent that any license, either express or implied, is granted under any patent right, copyright, mask work right, or other intellectual property right of TI covering or relating to any combination, machine, or process in which such semiconductor products or services might be or are used. TI's publication of information regarding any third party's products or services does not constitute TI's approval, warranty or endorsement thereof.