

# 9-Line 3-5 Volt SCSI Active Terminator, Reverse Disconnect

## FEATURES

- Complies with SCSI, SCSI-2 and SCSI-3 Standards
- 2.7V to 7V Operation
- 1.8pF Channel Capacitance during Disconnect
- 1µA Supply Current in Disconnect Mode
- 110 Ohm/2.5k Programmable Termination
- Completely Meets SCSI Hot Plugging
- -400mA Sourcing Current for Termination
- +400mA Sinking Current for Active Negation Drivers
- Trimmed Termination Current to 4%
- Trimmed Impedance to 7%
- Current Limit and Thermal Shutdown Protection

## DESCRIPTION

The UCC5606 provides 9 lines of active termination for a SCSI (Small Computer Systems Interface) parallel bus. The SCSI standard recommends active termination at both ends of the cable segment.

The UCC5606 is ideal for high performance 3.3V SCSI systems. The key features contributing to such low operating voltage are the 0.1V drop out regulator and the 2.7V reference. The reduced reference voltage was necessary to accommodate the lower termination current dictated in the SCSI-3 specification. During disconnect the supply current is typically only 1µA, which makes the IC attractive for battery powered systems.

The UCC5606 is designed with an ultra low channel capacitance of 1.8pF, which eliminates effects on signal integrity from disconnected terminators at interim points on the bus.

The UCC5606 can be programmed for either a 110 ohm or 2.5k ohm termination. The 110 ohm termination is used for standard SCSI bus lengths and the 2.5k ohm termination is typically used in short bus applications. When driving the TTL compatible DISCNCT pin directly, the 110 ohm termination is connected when the DISCNCT pin is driven high, and disconnected when low. When the DISCNCT pin is driven through an impedance between 80k and 150k, the 2.5k ohm termination is connected when the DISCNCT pin is driven high, and disconnected when driven low.

**continued**

## BLOCK DIAGRAM

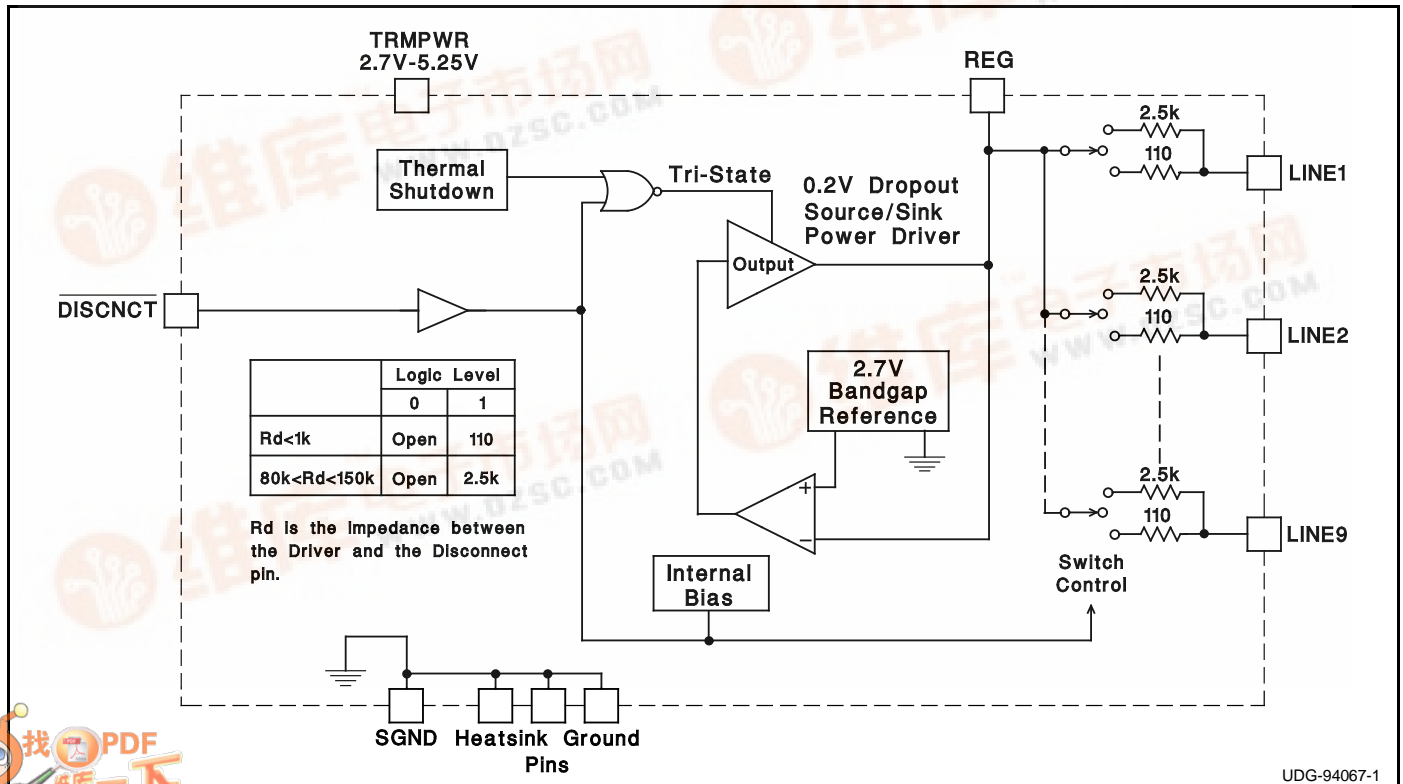

**Description Continued**

The power amplifier output stage allows the UCC5606 to source full termination current and sink active negation current when all termination lines are actively negated.

The UCC5606 is pin for pin compatible with Unitrode's other 9 line SCSI terminators, except that DISCNCT is now active low, allowing lower capacitance and lower voltage upgrades to existing systems. The UCC5606, as with all Unitrode terminators, is completely hot pluggable and appears as high impedance at the terminating channels with VTRMPWR = 0V or open.

Internal circuit trimming is utilized, first to trim the 110 ohm termination impedance to a 7% tolerance, and then most importantly, to trim the output current to a 4% tolerance, as close to the max SCSI-3 spec as possible, which maximizes noise margin in fast SCSI operation.

Other features include thermal shutdown and current limit.

This device is offered in low thermal resistance versions of the industry standard 16 pin narrow body SOIC, 16 pin ZIP (Zig-Zag In Line package), 24 pin TSSOP and 28 pin PLCC.

**ABSOLUTE MAXIMUM RATINGS**

Tempwr Voltage	..... +7V
Signal Line Voltage	..... 0V to +7V
Regulator Output Current	..... 0.6A
Storage Temperature	..... -65°C to +150°C
Operating Temperature	..... -55°C to +150°C
Lead Temperature (Soldering, 10 Sec.)	..... +300°C

*Unless otherwise specified all voltages are with respect to Ground. Currents are positive into, negative out of the specified terminal.*

*Consult Packaging Section of Unitrode Integrated Circuits data book for thermal limitations and considerations of packages.*

**RECOMMENDED OPERATING CONDITIONS**

Tempwr Voltage	..... 2.7V to 5.25V
Signal Line Voltage	..... 0V to +5V
Disconnect Input Voltage	..... 0V to Tempwr

**CONNECTION DIAGRAMS**

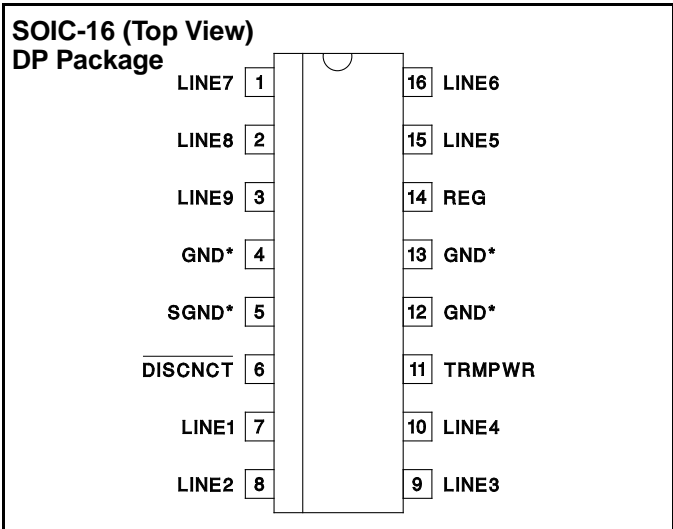
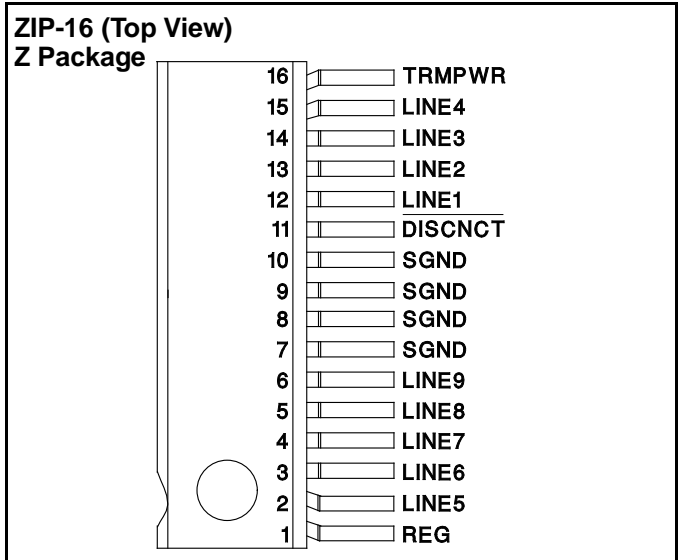

\* DP package pin 5 serves as signal ground; pins 4, 12, 13 serve as heatsink/ground.

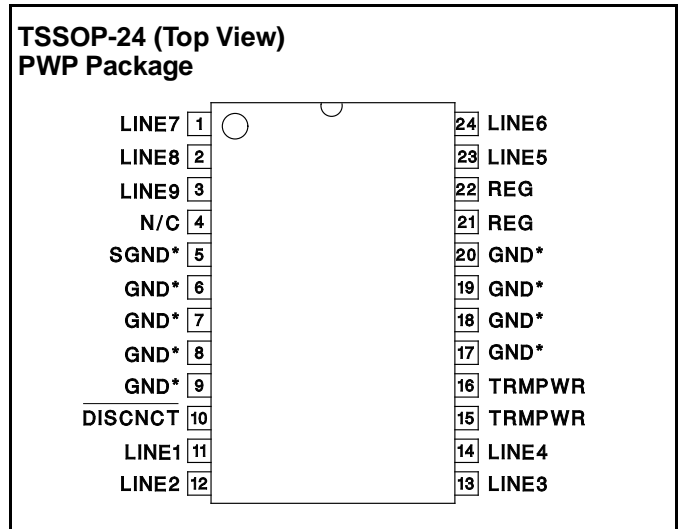

\* PWP package pin 5 serves as signal ground; pins 6, 7, 8, 9, 17, 18, 19, and 20 serve as heatsink/ground.

**CONNECTION DIAGRAMS (cont.)**

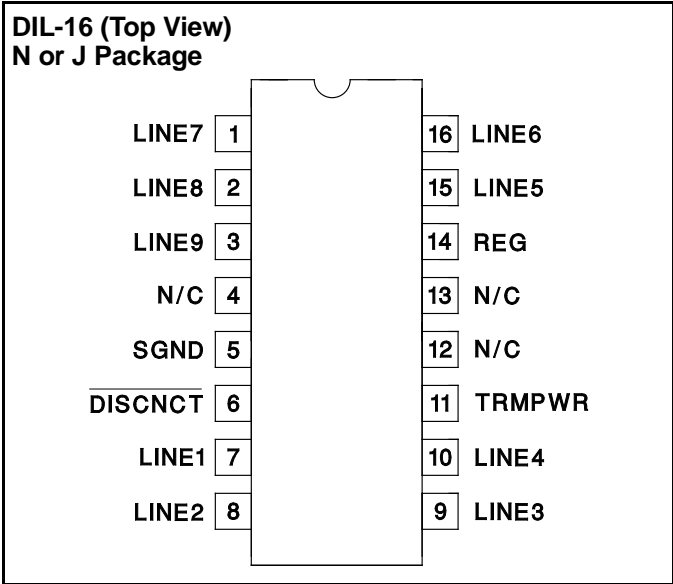

Note: Drawings are not to scale.

**ELECTRICAL CHARACTERISTICS** Unless otherwise stated, these specifications apply for TA = 0°C to 70°C. TRMPWR = 3.3V, DISCNCT = 3.3V, RDISCNCT = 0 ohms. TA = TJ.

PARAMETER	TEST CONDITIONS	MIN	TYP	MAX	UNITS
<b>Supply Current Section</b>					
Tempwr Supply Current	All termination lines = Open		1	2	mA
	All termination lines = 0.2V		210	218	mA
Power Down Mode	DISCNCT = 0V		0.5	5	µA
<b>Output Section (110 ohms - Terminator Lines)</b>					
Terminator Impedance		102.3	110	117.7	Ohms
Output High Voltage	TRMPWR = 3V (Note 1)	2.5	2.7	3.0	V
Max Output Current	VLINE = 0.2V, TJ = 25°C	-22.1	-23	-24	mA
	VLINE = 0.2V	-21	-23	-24	mA
	VLINE = 0.2V, TRMPWR = 3V, TJ = 25°C (Note 1)	-20.2	-23	-24	mA
	VLINE = 0.2V, TRMPWR = 3V (Note 1)	-19	-23	-24	mA
	VLINE = 0.5V			-22.4	mA
Output Leakage	DISCNCT = 0V, TRMPWR = 0V to 5.25V		10	400	nA
Output Capacitance	DISCNCT = 0V, DP Package (Note 2)		1.8	2.5	pF
<b>Output Section (2.5k ohms - Terminator Lines) (RDISCNCT = 80k ohms)</b>					
Terminator Impedance		2	2.5	3	kΩ
Output High Voltage	TRMPWR = 3V (Note 1)	2.5	2.7	3.0	V
Max Output Current	VLINE = 0.2V	-0.7	-1	-1.4	mA
	VLINE = 0.2V, TRMPWR = 3V (Note 1)	-0.6	-1	-1.5	mA
Output Leakage	DISCNCT = 0V, TRMPWR = 0 to 5.25V		10	400	nA
Output Capacitance	DISCNCT = 0V, DP Package (Note 2)		1.8	2.5	pF
<b>Regulator Section</b>					
Regulator Output Voltage	5.25V > TRMPWR > 3V	2.5	2.7	3.0	V
Drop Out Voltage	All Termination Lines = 0.2V		0.1	0.2	V

**ELECTRICAL CHARACTERISTICS (cont.)** Unless otherwise stated, these specifications apply for  $T_A=0^{\circ}\text{C}$  to  $70^{\circ}\text{C}$ .  
 $\text{TRMPWR} = 3.3\text{V}$ ,  $\text{DISCNCT} = 3.3\text{V}$ ,  $\text{RDISCNCT} = 0$  ohms.  $T_A = T_J$ .

PARAMETER	TEST CONDITIONS	MIN	TYP	MAX	UNITS
<b>Regulator Section (cont.)</b>					
Short Circuit Current	$V_{\text{REG}} = 0\text{V}$	-200	-400	-800	mA
Sinking Current Capability	$V_{\text{REG}} = 3\text{V}$	200	400	800	mA
Thermal Shutdown	(Note 2)		170		$^{\circ}\text{C}$
Thermal Shutdown Hysteresis	(Note 2)		10		$^{\circ}\text{C}$
<b>Disconnect Section</b>					
Disconnect Threshold	$\text{RDISCNCT} = 0$ & $80\text{k}$	0.8	1.5	2.0	V
Input Current	$\text{DISCNCT} = 3.3\text{V}$		30	50	$\mu\text{A}$

Note 1: Measuring each termination line while other 8 are low (0.2V).  
 Note 2: Guaranteed by design. Not 100% tested in production.

**APPLICATION INFORMATION**

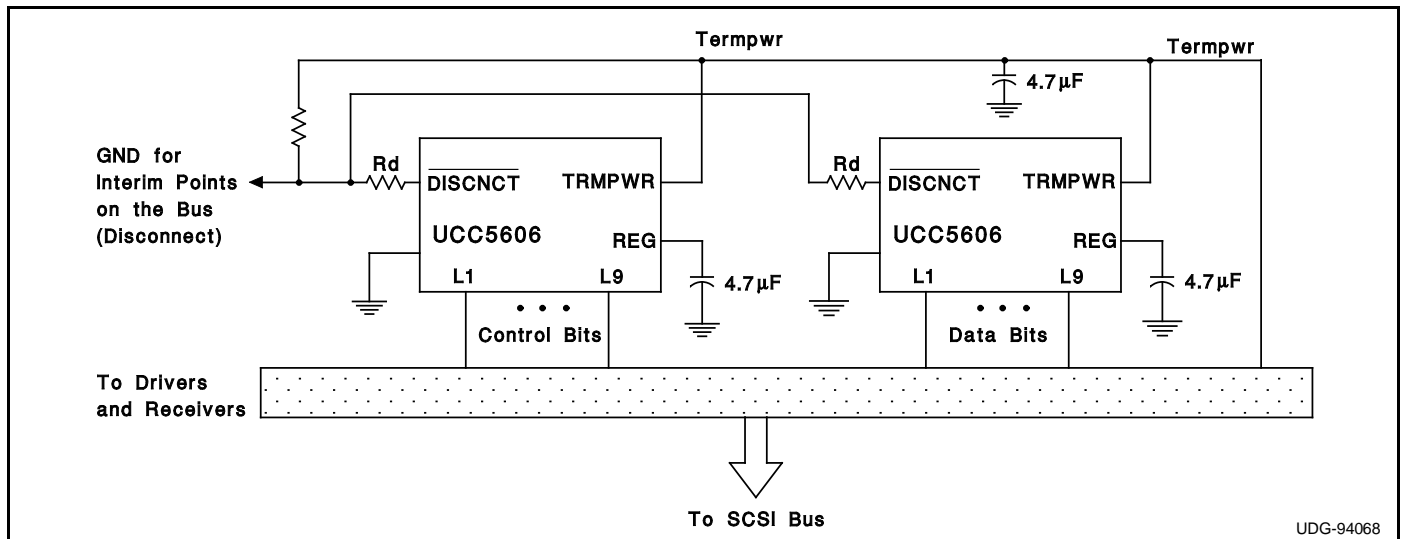

Figure 1: Typical SCSI Bus Configurations Utilizing 2 UCC5606 Devices

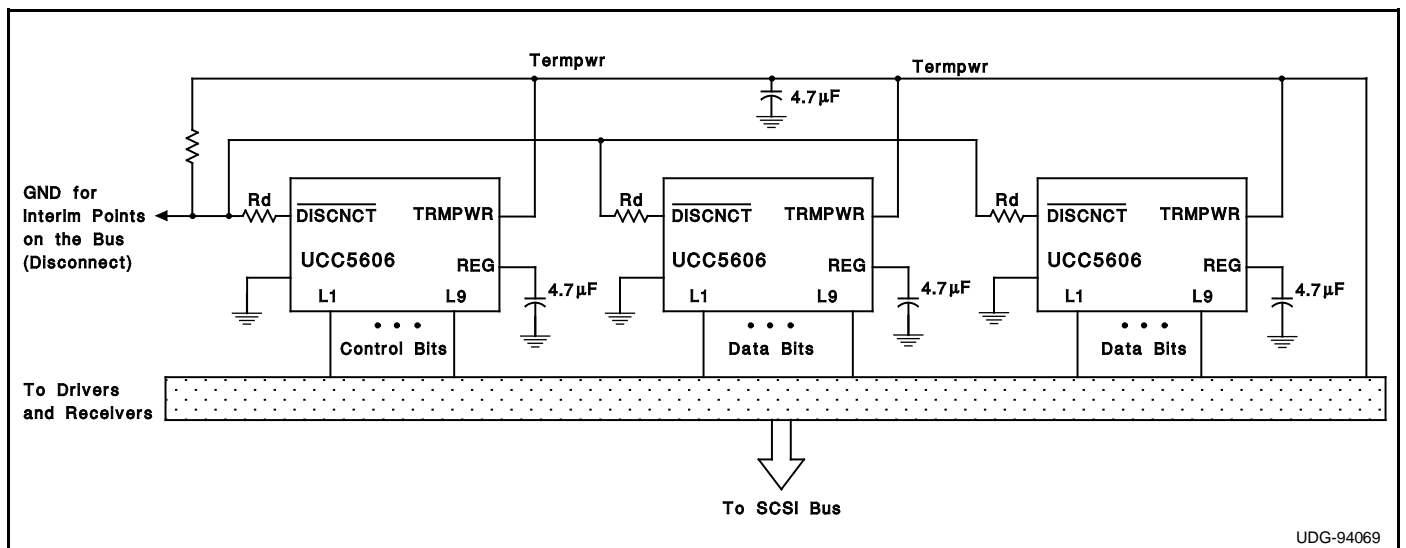

Figure 2: Typical Wide SCSI Bus Configurations Utilizing 3 UCC5606 Devices.

## **IMPORTANT NOTICE**

Texas Instruments and its subsidiaries (TI) reserve the right to make changes to their products or to discontinue any product or service without notice, and advise customers to obtain the latest version of relevant information to verify, before placing orders, that information being relied on is current and complete. All products are sold subject to the terms and conditions of sale supplied at the time of order acknowledgement, including those pertaining to warranty, patent infringement, and limitation of liability.

TI warrants performance of its semiconductor products to the specifications applicable at the time of sale in accordance with TI's standard warranty. Testing and other quality control techniques are utilized to the extent TI deems necessary to support this warranty. Specific testing of all parameters of each device is not necessarily performed, except those mandated by government requirements.

**CERTAIN APPLICATIONS USING SEMICONDUCTOR PRODUCTS MAY INVOLVE POTENTIAL RISKS OF DEATH, PERSONAL INJURY, OR SEVERE PROPERTY OR ENVIRONMENTAL DAMAGE ("CRITICAL APPLICATIONS"). TI SEMICONDUCTOR PRODUCTS ARE NOT DESIGNED, AUTHORIZED, OR WARRANTED TO BE SUITABLE FOR USE IN LIFE-SUPPORT DEVICES OR SYSTEMS OR OTHER CRITICAL APPLICATIONS. INCLUSION OF TI PRODUCTS IN SUCH APPLICATIONS IS UNDERSTOOD TO BE FULLY AT THE CUSTOMER'S RISK.**

In order to minimize risks associated with the customer's applications, adequate design and operating safeguards must be provided by the customer to minimize inherent or procedural hazards.

TI assumes no liability for applications assistance or customer product design. TI does not warrant or represent that any license, either express or implied, is granted under any patent right, copyright, mask work right, or other intellectual property right of TI covering or relating to any combination, machine, or process in which such semiconductor products or services might be or are used. TI's publication of information regarding any third party's products or services does not constitute TI's approval, warranty or endorsement thereof.