



UC1620  
UC3620

## Switchmode Driver for 3- $\phi$ Brushless DC Motors

### FEATURES

- 2A Continuous, 3A Peak Output Current
- 8V to 40V Operation
- Internal High Gain Amplifier for Velocity Control Applications
- TTL Compatible Hall Inputs
- Mask Programmable Decode Logic
- Pulse-by-Pulse Current Limiting
- Internal Thermal Shutdown Protection
- Under-Voltage Lockout
- Available in SP Hermetic Package

### DESCRIPTION

The UC3620 is a brushless DC motor driver capable of decoding and driving all 3 windings of a 3-phase brushless DC motor. In addition, an on-board current comparator, oscillator, and high gain Op-Amp provide all necessary circuitry for implementing a high performance, chopped mode servo amplifier. Full protection, including thermal shutdown, pulse-by-pulse current limiting, and under-voltage lockout aid in the simple implementation of reliable designs. Both conducted and radiated EMI have been greatly reduced by limiting the output dv/dt to 150V/ $\mu$ s for any load condition.

The UC1620SP is characterized for operation over the full military temperature range of -55°C to +125°C, while the UC3620SP is characterized for 0°C to +70°C.

### BLOCK DIAGRAM

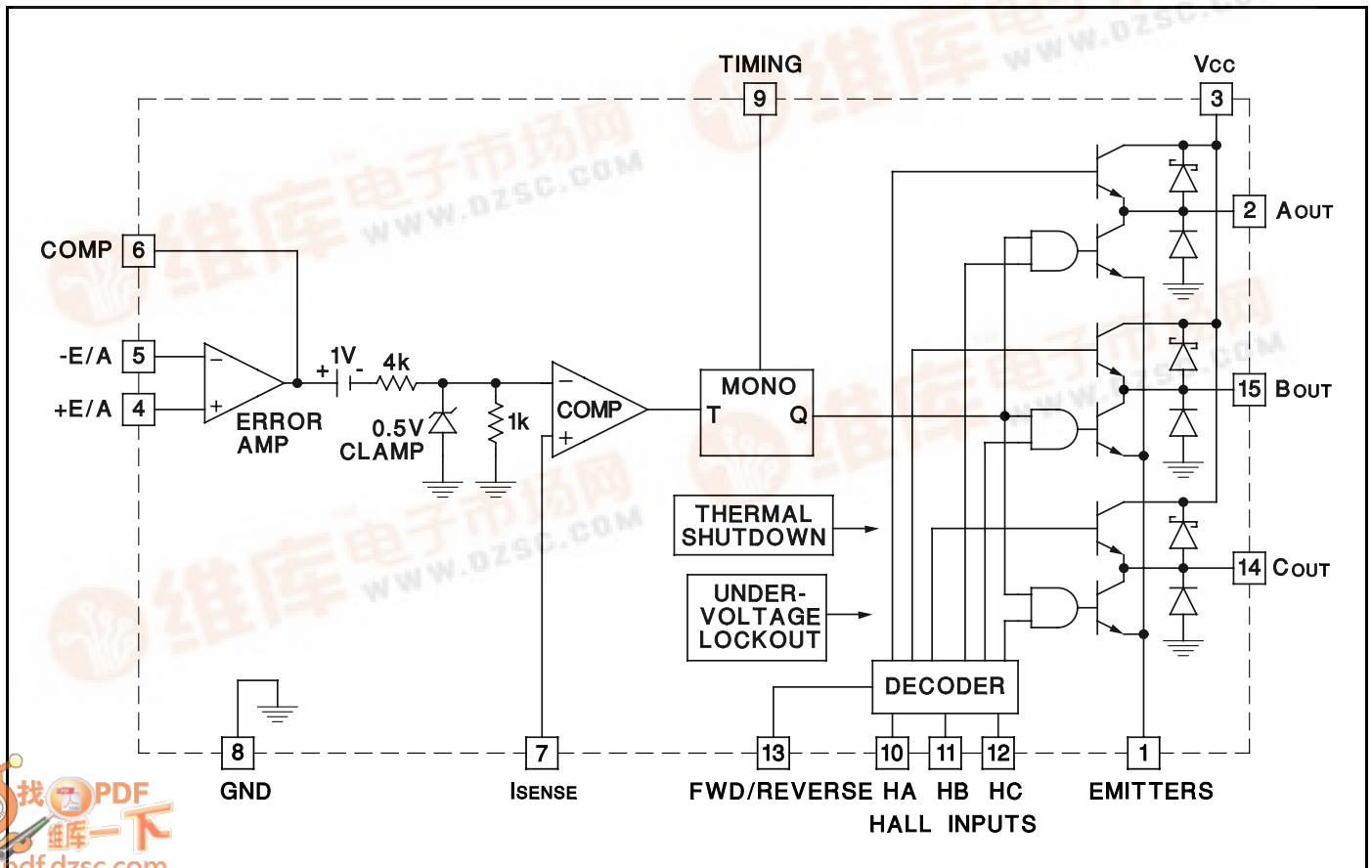

**ABSOLUTE MAXIMUM RATINGS** (Note 1)

Supply Voltage, Vcc	40V
Output Current, Source or Sink	
Non-Repetitive (t = 100µsec), Io	3A
Repetitive (80% on - 20% off; tON = 10ms)	2.5A
DC Operation	2A
Analog Inputs	-0.3 to +Vcc
Logic Inputs	-0.3 to +Vcc
Total Power Dissipation (at TCASE = 75° C)	
for SP Package (Note 2)	15W
Storage Temperature	-65°C to +150°C
Operating Junction Temperature	-55°C to +150°C

Note 1: All voltages are with respect to ground. Currents are positive into, negative out of the specified terminal.

Note 2: Consult Packaging Section of Databook for thermal limitations and considerations of package.

**CONNECTION DIAGRAMS**

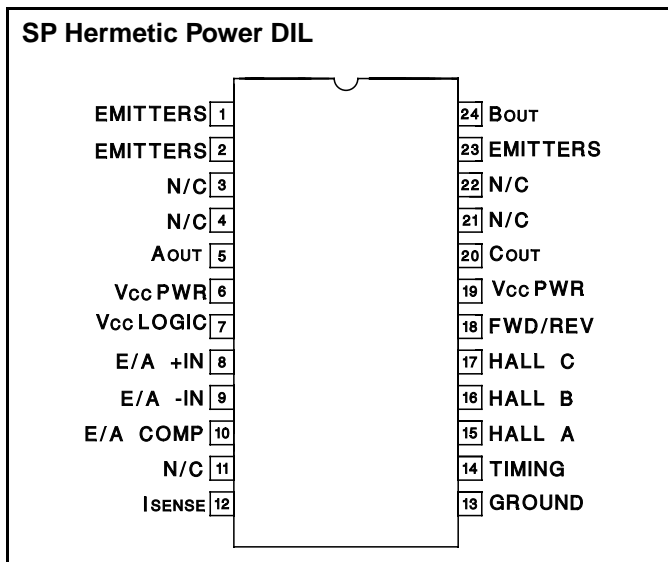

**ELECTRICAL CHARACTERISTICS:** Unless otherwise stated, these specifications apply for TA = 0°C to 70°C for 3620; TA = 55°C to +125°C for UC1620; VCC = 20V, RT = 20V, RT = 10k, CT = -2.2nF. TA=TJ.

PARAMETER	TEST CONDITIONS	UC3620			UC1620			UNIT
		MIN	TYP	MAX	MIN	TYP	MAX	
<b>Error Amplifier Section</b>								
Input Offset Voltage			1.5	10		1.5	10	mV
Input Bias Current			-.25	-2.0		-.25	-2.0	µA
Input Offset Current			15	250		15	250	nA
Common Mode Range	Vcc = 8V to 40V	0		VIN-2	0		VIN-2	V
Open Loop Gain	ΔVCOMP = 1V to 4V	80	100		75	100		dB
Unity Gain Bandwidth	TJ = 25°C, Note 2		0.8			0.8		MHz
Output Sink Current	VCOMP = 1V		2			2		mA
Output Source Current	VCOMP = 4V		8			8		mA
<b>Current Sense Section</b>								
Input Bias Current			-2.0	-5		-2.0	-5	µA
Internal Clamp		.425	0.5	.575	.405	0.5	.595	V
Divider Gain		.180	0.2	.220	.170	0.2	.230	V/V
Internal Offset Voltage		.8	1.0	1.2	.75	1.0	1.25	V
<b>Timing Section</b>								
Output Off Time		18	20	22	17	20	23	µs
Upper Mono Threshold			5.0			5.0		V
Lower Mono Threshold			2.0			2.0		V
<b>Decoder Section</b>								
High-Level Input Voltage		2.2			2.5			V
Low-Level Input Voltage				0.8			0.8	V
High-Level Input Current				10			10	µA
Low-Level Input Current		-10			-10			µA
<b>Output Section</b>								
Output Leakage Current	Vcc = 40V			500			1500	µA
VF1 Schottky Diode	Io = 2A		1.5	2.0		1.5	2.0	V
VF1 Substrate Diode	Io = 2A		2.2	3.0		2.2	3.0	V
Total Output Voltage Drop	Io = 2A, Note 3		3.0	3.6		3.0	3.6	V

**ELECTRICAL CHARACTERISTICS:** Unless otherwise stated, these specifications apply for  $T_A = 0^\circ\text{C}$  to  $70^\circ\text{C}$  for 3620;  $T_A = 55^\circ\text{C}$  to  $+125^\circ\text{C}$  for UC1620;  $V_{CC} = 20\text{V}$ ,  $R_T = 20\text{V}$ ,  $R_T = 10\text{k}$ ,  $C_T = -2.2\text{nF}$ .  $T_A = T_J$ .

PARAMETER	TEST CONDITIONS	UC3620			UC1620			UNIT
		MIN	TYP	MAX	MIN	TYP	MAX	
<b>Output Section (cont.)</b>								
Output Rise Time	$R_L = 44\Omega$		150			150		ns
Output Fall Time	$R_L = 44\Omega$		150			150		ns
<b>Under Voltage Lockout</b>								
Startup Threshold				8.0			8.0	V
Threshold Hysteresis			0.5			0.5		V
<b>Thermal Shutdown</b>								
Junction Temperature	Note 2	150		180	150		180	$^\circ\text{C}$
<b>Total Standby Current</b>								
Supply Current			32	55		32	55	mA

Note 2: These parameters, although guaranteed over the recommended operating conditions, are not 100% tested in production.  
Note 3: The total voltage drop is defined as the sum of both top and bottom side driver.

**TABLE 1**

STEP	FWD/REV	Ha	Hb	Hc	AOUT	BOUT	COUT
1	1	1	0	1	H	L	O
2	1	1	0	0	H	O	L
3	1	1	1	0	O	H	L
4	1	0	1	0	L	H	O
5	1	0	1	1	L	O	H
6	1	0	0	1	O	L	H
1	0	1	0	1	L	H	O
2	0	1	0	0	L	O	H
3	0	1	1	0	O	L	H
4	0	0	1	0	H	L	O
5	0	0	1	1	H	O	L
6	0	0	0	1	O	H	L

H = HIGH OUTPUT  
L = LOW OUTPUT  
O = OPEN OUTPUT

**CIRCUIT DESCRIPTION**

The UC3620 is designed for implementation of a complete 3- $\phi$  brushless DC servo drive using a minimum number of external components. Below is a functional description of each major circuit feature.

**DECODER**

Table 1 shows the decoding scheme used in the UC3620 to decode and drive each of three high current totem pole output stages. A forward/reverse signal, pin 13, is used to provide direction. At any point in time, one driver is sourcing, one driver is sinking, and the remaining driver is off or tri-stated. Pulse width modulation is accomplished by turning the sink driver off during the monostable reset time, producing a fixed off-time chop mode. Controlled output rise and fall times help reduce electrical switching noise while maintaining relatively small switching losses.

Hall lines require pull-up resistors.

**CURRENT SENSING**

Referring to Figure 1, emitter current is sensed across  $R_s$  and fed back through a low pass filter to the current sense pin 7. This filter is required to eliminate false triggering of the monostable due to leading edge current spikes. Actual filter values, although somewhat dependent on external loads, will generally be in the  $1\text{k}\Omega$  and  $1000\text{pF}$  range.

**TIMING**

An R-C time constant on pin 9 is used by the monostable to generate a fixed off time at the outputs according to the formula:

$$T_{OFF} = .916RTCT$$

As the peak current in the emitters approaches the value at the minus (-) input of the on-board comparator, the monostable is triggered, causing the outputs to be turned

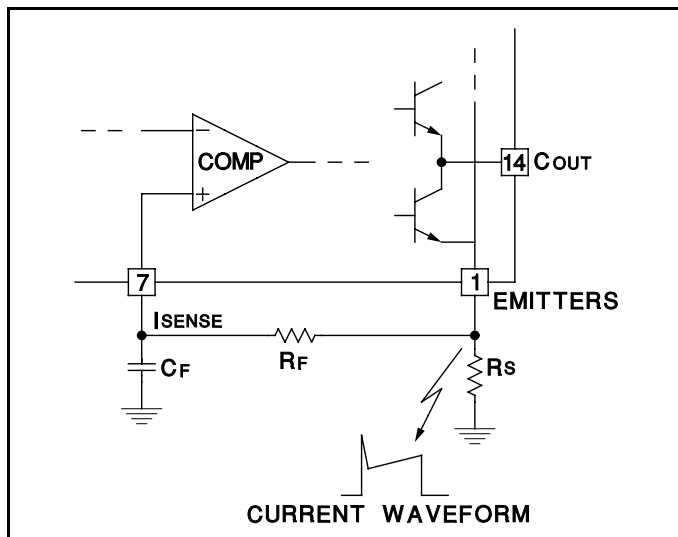

Figure 1. Current Sense Filter

### CIRCUIT DESCRIPTION (cont.)

off. On time is determined by the amount of time required for motor current to increase to the value required to re-trip the monostable. A timing sequence of these events is shown in Figure 2.

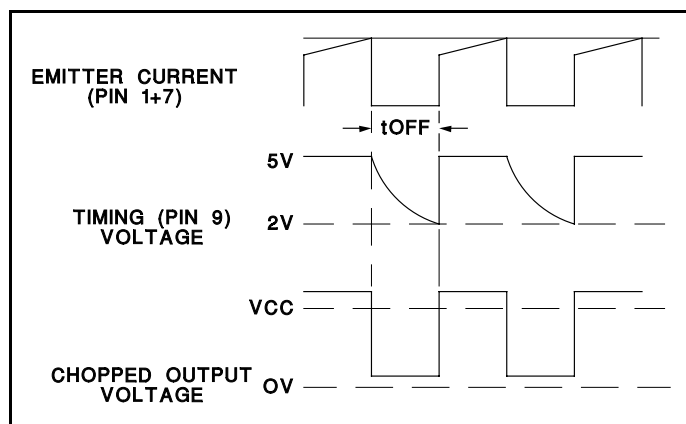

Figure 2. Chopped Mode Timing Diagram

### CURRENT LIMIT

Since peak current is being controlled at all times by the internal comparator, a simple voltage clamp at its negative (-) input will limit peak current to a maximum value. A fixed 0.5V internal clamp has been included on the UC3620, and any current spike in the output which generates a sensed voltage greater than 0.5V will immediately shut down the outputs. Actual peak current values may be programmed by selecting the appropriate value of  $R_s$  according to the formula:

$$R_s = \frac{0.5}{I_{CURRENTLIMIT}}$$

Since peak current is being controlled at all times by the internal comparator, a simple voltage clamp at its nega-

tive (-) input will limit peak current to a maximum value. A fixed 0.5V internal clamp has been included on the UC3620, and any current spike in the output which generates a sensed voltage greater than 0.5V will immediately shut down the outputs. Actual peak current values may be programmed by selecting the appropriate value of  $R_s$  according to the formula:

$$R_s = \frac{0.5}{I_{CURRENTLIMIT}}$$

### ERROR AMPLIFIER LIMIT

A high performance, on-board error amplifier is included to facilitate implementing closed loop motor control. Error voltage generation and loop compensation are easily accomplished by appropriately configuring the gain and feedback of this amplifier. To provide a larger dynamic signal range at the output of the error amplifier, a divide by 5 resistor network is used to reduce the error signal level before applying to the internal comparator. In addition, a one volt offset has been introduced at the output of the error amplifier to guarantee control down to zero current in the output stages. Since this offset is divided by the open loop gain of the feedback loop, it has virtually no effect on closed loop performance.

### PROTECTION FUNCTIONS

Protective functions including under-voltage lockout, peak current limiting, and thermal shutdown, provide an extremely rugged device capable of surviving under many types of fault conditions. Under-voltage lockout guarantees the outputs will be off or tri-stated until  $V_{CC}$  is sufficient for proper operation of the chip. Current limiting limits the peak current for a stalled or shorted motor, whereas thermal shutdown will tri-state the outputs if a temperature above 150°C is reached.





## **IMPORTANT NOTICE**

Texas Instruments and its subsidiaries (TI) reserve the right to make changes to their products or to discontinue any product or service without notice, and advise customers to obtain the latest version of relevant information to verify, before placing orders, that information being relied on is current and complete. All products are sold subject to the terms and conditions of sale supplied at the time of order acknowledgement, including those pertaining to warranty, patent infringement, and limitation of liability.

TI warrants performance of its semiconductor products to the specifications applicable at the time of sale in accordance with TI's standard warranty. Testing and other quality control techniques are utilized to the extent TI deems necessary to support this warranty. Specific testing of all parameters of each device is not necessarily performed, except those mandated by government requirements.

**CERTAIN APPLICATIONS USING SEMICONDUCTOR PRODUCTS MAY INVOLVE POTENTIAL RISKS OF DEATH, PERSONAL INJURY, OR SEVERE PROPERTY OR ENVIRONMENTAL DAMAGE ("CRITICAL APPLICATIONS"). TI SEMICONDUCTOR PRODUCTS ARE NOT DESIGNED, AUTHORIZED, OR WARRANTED TO BE SUITABLE FOR USE IN LIFE-SUPPORT DEVICES OR SYSTEMS OR OTHER CRITICAL APPLICATIONS. INCLUSION OF TI PRODUCTS IN SUCH APPLICATIONS IS UNDERSTOOD TO BE FULLY AT THE CUSTOMER'S RISK.**

In order to minimize risks associated with the customer's applications, adequate design and operating safeguards must be provided by the customer to minimize inherent or procedural hazards.

TI assumes no liability for applications assistance or customer product design. TI does not warrant or represent that any license, either express or implied, is granted under any patent right, copyright, mask work right, or other intellectual property right of TI covering or relating to any combination, machine, or process in which such semiconductor products or services might be or are used. TI's publication of information regarding any third party's products or services does not constitute TI's approval, warranty or endorsement thereof.