



IrDA 115.2kbps Transceiver

PRELIMINARY

FEATURES

- Supports IrDA Standard to 115kbps Data Rates
- 3V to 5V Operation
- Wide Dynamic Receiver Range from 200nA to 50mA Typical
- IrDA Compliant I/O
- 500mA LED Driver
- Very Low Quiescent Current in Active Mode (250µA Typical)
- Ultra Low Quiescent Current in Sleep Mode (0.5µA Typical)
- Compatible with IrDA Detector Diodes

DESCRIPTION

The UCC5342 IrDA (Infrared Data Association) Transceiver supports the analog section of the IrDA standard. The receiver has a limiting transresistance amplifier to detect a current signal from a PIN diode and drives RXX pulses to a UART. The amplifier is capable of input currents ranging from 200nA to 50mA. The amplifier is bandpass limited to reduce interference from other IR sources.

The output of the receiver is designed to drive CMOS and TTL levels, for direct interfacing to IrDA compliant UARTs and Super I/O devices. Internal resistors are provided for decoupling the detector diode supply, thus minimizing the number of external components required.

The transmitter portion of the chip has a low impedance open drain MOSFET output. It is capable of sinking 300mA from an output LED at 3V, and 500mA at 5V.

BLOCK DIAGRAM

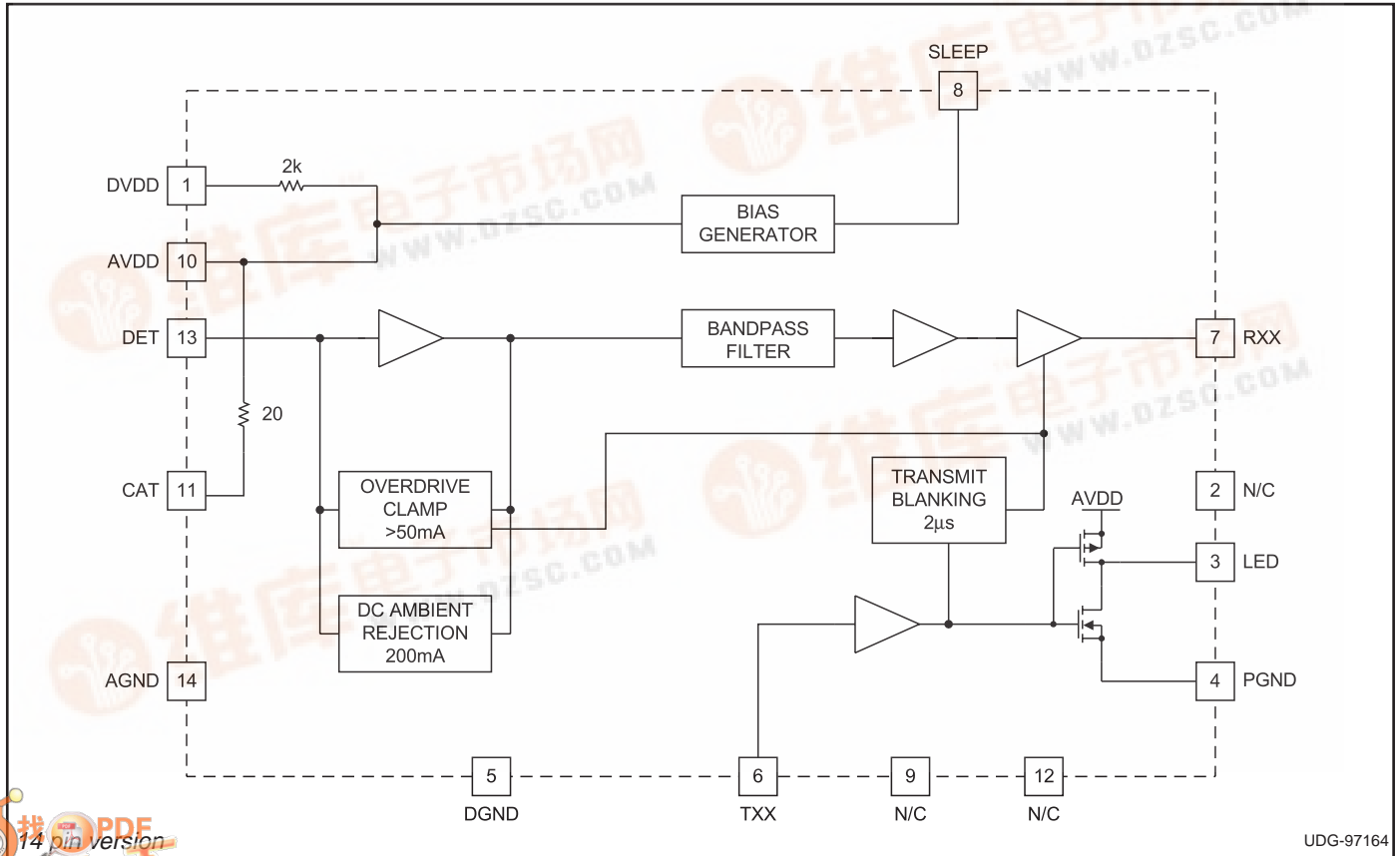

ABSOLUTE MAXIMUM RATINGS

AVDD, DVDD, CAT -0.3V to 7V
 SLEEP, DET, TXX, LED,
 DVDD, CAT -0.3V to AVDD + 0.3V
 IRXX -10mA to 10 mA
 IDET 250mA
 ILED 1A
 Storage Temperature -65°C to +150°C
 Junction Temperature -55°C to +150°C
 Lead Temperature (Soldering, 10sec.) +300°C

All voltages are with respect to respect to AGND. DGND and PGND must be connected to AGND. Currents are positive into, negative out of the specified terminal. Consult Packaging Section of the Databook for thermal limitations and considerations of packages.

CONNECTION DIAGRAM

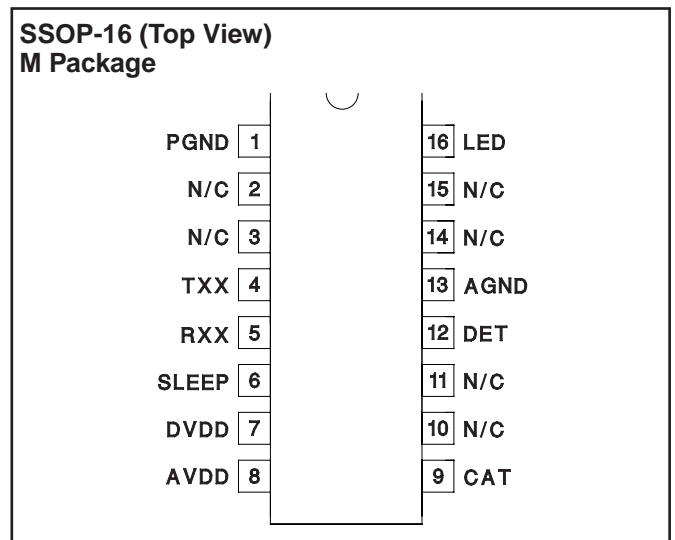
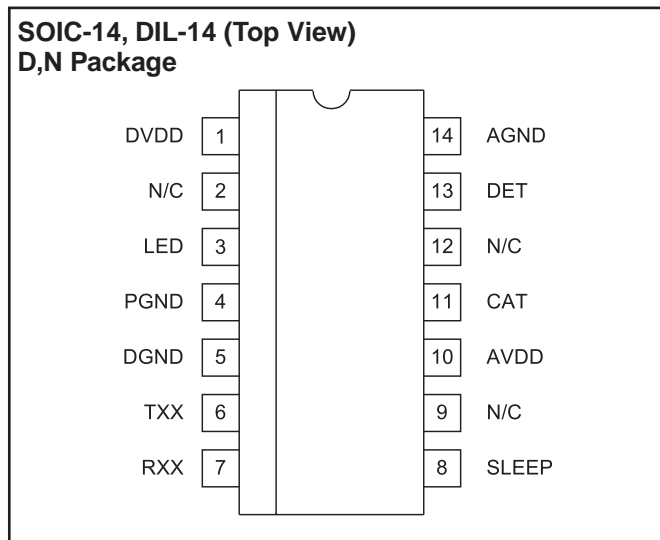

ELECTRICAL CHARACTERISTICS: Unless otherwise specified, TA = 0°C to 70°C, AVDD = 3.0V to 5.5V, CAVDD = 100nF, CDVDD = 100nF, CCAT = 4.7µF + 100nF, CRXX = 40pF, CDET < 56pF. TA = TJ.

PARAMETER	TEST CONDITION	MIN	TYP	MAX	UNITS
Supply Current Section					
IDD	No Output Load, SLEEP ≤ 0.5V		250	350	µA
IDD	SLEEP ≥ AVDD - 0.5V, TXX ≤ 0.5V		0.5	3	µA
RDVDD	AVDD to DVDD	1.0	2	3.0	kΩ
RCAT	AVDD to CAT	10	20	32	Ω
Receiver Section					
Input Referred Noise	(Note 1)		10		$\frac{\mu A}{\sqrt{Hz}}$
Detection Threshold	1.6µs Input Pulse, 1µs ≤ RXX ≤ 8µs		200	400	nA
Signal to Noise Ratio	IDET = 200nA (Note 1)		11.8		
Lower Band Limit	(Note 1)		50		kHz
Upper Band Limit	(Note 1)		1		MHz
Output Pulse Width	IDET = 400nApk to 20mApk, 0 to 200µADC, 1.6µs Input Pulse	1.0		8.0	µs
RXX Output (VOL)	IRXX = 800µA		200	400	mV
RXX Output (VOH)	IRXX = -100µA, DVDD - RXX		200	400	mV
RXX Rise Time	From 10% to 90% of DVDD		150	200	ns
RXX Fall Time	From 90% to 10% of DVDD		100	150	ns

ELECTRICAL CHARACTERISTICS (cont.): Unless otherwise specified, $T_A = 0^{\circ}\text{C}$ to 70°C , $AVDD = 3.0\text{V}$ to 5.5V , $CAVDD = 100\text{nF}$, $CDVDD = 100\text{nF}$, $CCAT = 4.7\mu\text{F} + 100\text{nF}$, $CRXX = 40\text{pF}$, $CDET < 56\text{pF}$. $T_A = T_J$.

PARAMETER	TEST CONDITION	MIN	TYP	MAX	UNITS
Transmitter Section					
I_{TXX}	$TXX = 0$ to $AVDD$	-10		10	μA
$TXX (V_{IH})$			2	2.5	V
$TXX (V_{IL})$		0.8	1		V
LED	$TXX = AVDD = 4.5\text{V}$, $I_{LED} = 500\text{mA}$		0.3	0.6	V
	$TXX = AVDD = 3.0\text{V}$, $I_{LED} = 300\text{mA}$		0.3	0.6	V
$AVDD - LED$	$TXX = 0$, $AVDD = 3.0\text{V}$, $I_{LED} = -1\text{mA}$		0.2	0.6	V

Note 1: Guaranteed by design. Not 100% tested in production.

PIN DESCRIPTIONS

AGND: Ground reference for analog circuits. Connect to circuit board ground plane.

AVDD: Supply pin for analog circuits. Bypass to AGND with a 100nF or 1 μF ceramic capacitor.

CAT: Filtered supply for PIN diode cathode. Internally connected to AVDD with a 20 Ω resistor. Bypass to AGND with a 4.7 μF capacitor plus a 100nF ceramic capacitor.

DET: Input to receiver amplifier. Connect to PIN diode anode. Shield with a AVDD and/or AGND from all other signals, especially RXX.

DGND: Ground pin for digital circuits. Connect to circuit board ground plane.

DVDD: Supply pin for digital circuits. Internally connected

to AVDD with a 2k Ω resistor. Bypass to DGND with a 100nF or 1 μF ceramic capacitor.

LED: Open drain of transmitter output transistor. Connect to an external IrDA compliant light emitting diode via an external resistor.

PGND: Source of transmitter output transistor. Connect to circuit board ground plane.

RXX: Output of the detect amplifier and buffer. Connect to UART. Avoid coupling the RXX signal to DET.

SLEEP: Sleep mode select pin. A logic high on SLEEP puts the chip into sleep mode, reducing I_{DD} to 0.5 μA typical.

TXX: Input from UART to transmit LED driver.

APPLICATION INFORMATION

Ground Plane

There are 3 ground connections shown on the application drawing, representing the sensitive analog ground, the 'dirty' digital ground and the high current transmitter ground. These 3 points can simply be geographic groupings of connections to a ground plane. If a ground plane is not used, other provision to isolate the analog and digital ground currents should be provided. The use of a ground plane is strongly recommended.

DET Considerations

DET is flanked by AGND and an unconnected pin. This should be used to good advantage by fully enclosing the DET circuit board trace with AGND in order to shield leakage noise from DET. The DET circuit board trace length should be minimized. Since the PIN diode connected to DET is capacitive, noise coupling to the cathode of the diode will be coupled directly to DET. For this reason, the 100nF capacitor on CAT should be located physically close to the cathode of the PIN diode.

There is natural parasitic coupling from RXX to DET. RXX should be routed to minimize the parasitic capacitive coupling from RXX to DET.

Analog Power Supply Decoupling

The UCC3542 has a highly sensitive amplifier section capable of detecting extremely low current levels (200nA typical). Achieving this sensitivity requires quiet analog power supply rails. A 100nF high frequency capacitor in close proximity to AVDD and AGND is required for quiet analog rails.

The transmitter section of the chip runs from the AVDD supply and draws high peak currents (~500mA in a typical application). A bulk capacitor may be required close to the AVDD and AGND pins if the connection length to the power supply is long, or if the supply is relatively high impedance. This bulk capacitor is in addition to the 100nF high frequency capacitor mentioned above. The bypass capacitors on CAT and AVDD should present very low equivalent series resistance and inductance to the circuit.

APPLICATION INFORMATION (cont.)

Digital Power Supply

DVDD is fed directly from AVDD through an internal 2k resistor. The DVDD bypass capacitor handles all transient current produced by the digital section of the chip. If more drive is required from RXX, than the internal 2k resistor will allow, an external resistor can shunt it. This technique should always be accompanied by increasing

the value of the decoupling capacitor on DVDD and AVDD.

Economy Application

The diagram of the economy application shows only one bypass capacitor. This application is suitable where maximum sensitivity is not required and where the power supply feeding AVDD is relatively clean and low impedance.

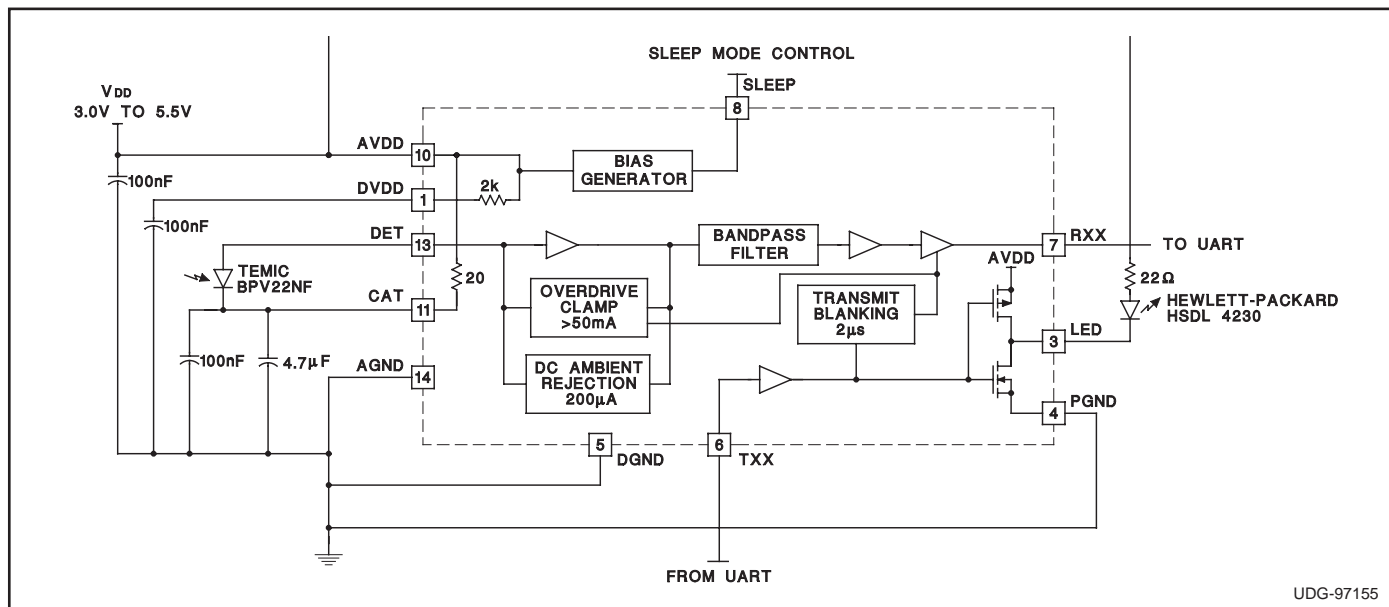

Figure 1. Typical Application of the UCC5342

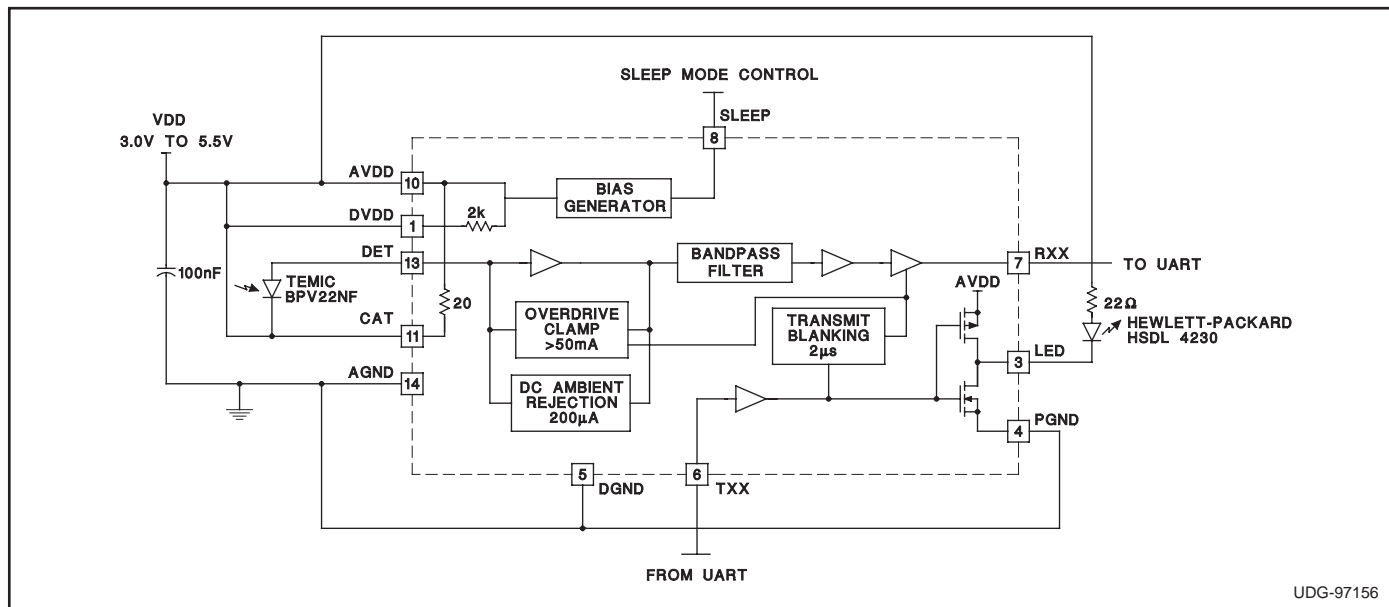

Figure 2. Economy Application of the UCC5342

IMPORTANT NOTICE

Texas Instruments and its subsidiaries (TI) reserve the right to make changes to their products or to discontinue any product or service without notice, and advise customers to obtain the latest version of relevant information to verify, before placing orders, that information being relied on is current and complete. All products are sold subject to the terms and conditions of sale supplied at the time of order acknowledgement, including those pertaining to warranty, patent infringement, and limitation of liability.

TI warrants performance of its semiconductor products to the specifications applicable at the time of sale in accordance with TI's standard warranty. Testing and other quality control techniques are utilized to the extent TI deems necessary to support this warranty. Specific testing of all parameters of each device is not necessarily performed, except those mandated by government requirements.

CERTAIN APPLICATIONS USING SEMICONDUCTOR PRODUCTS MAY INVOLVE POTENTIAL RISKS OF DEATH, PERSONAL INJURY, OR SEVERE PROPERTY OR ENVIRONMENTAL DAMAGE ("CRITICAL APPLICATIONS"). TI SEMICONDUCTOR PRODUCTS ARE NOT DESIGNED, AUTHORIZED, OR WARRANTED TO BE SUITABLE FOR USE IN LIFE-SUPPORT DEVICES OR SYSTEMS OR OTHER CRITICAL APPLICATIONS. INCLUSION OF TI PRODUCTS IN SUCH APPLICATIONS IS UNDERSTOOD TO BE FULLY AT THE CUSTOMER'S RISK.

In order to minimize risks associated with the customer's applications, adequate design and operating safeguards must be provided by the customer to minimize inherent or procedural hazards.

TI assumes no liability for applications assistance or customer product design. TI does not warrant or represent that any license, either express or implied, is granted under any patent right, copyright, mask work right, or other intellectual property right of TI covering or relating to any combination, machine, or process in which such semiconductor products or services might be or are used. TI's publication of information regarding any third party's products or services does not constitute TI's approval, warranty or endorsement thereof.