



UCC5340
PRELIMINARY

IrDA Receiver

FEATURES

- Micro Power, 90 μ A Typical Operating Current
- 3.3V or 5V Operation
- 8-Pin SOIC Package
- 1 cm to 1 Meter IrDA Link Compliance
- Directly Interfaces to IrDA Compatible UARTS and Super I/O Chips
- Supports Data Rates from 2400 to 115.2KBits/Second
- CMOS/TTL Compatible Output
- ASK Modulation Compatible
- Drop in compatible with Irvine Sensor SIR2

DESCRIPTION

The UCC5340 is a dual voltage, micropower, IrDA (Infrared Data Association) compliant receiver. It's high gain photodiode input amplifier incorporates a unique limiting circuit which permits operation over a very wide dynamic input range. The integrated bandpass filter includes additional limiting circuitry, further reducing device recovery time requirements, allowing the UCC5340 to directly interface with IrDA compatible detector diodes.

The output is capable of driving a 40pF load at CMOS/TTL levels for direct interfacing to IrDA compliant UARTs or Super I/O devices over a 2400BPS to 115.2kBPS range.

A control pin is provided to allow operation with either 3.3V or 5V supplies. The circuit requires only 90 μ A (nominal) operating current in either configuration. An internal 2k Ω resistor is provided for decoupling the detector supply, to minimize the number of external components required.

BLOCK DIAGRAM

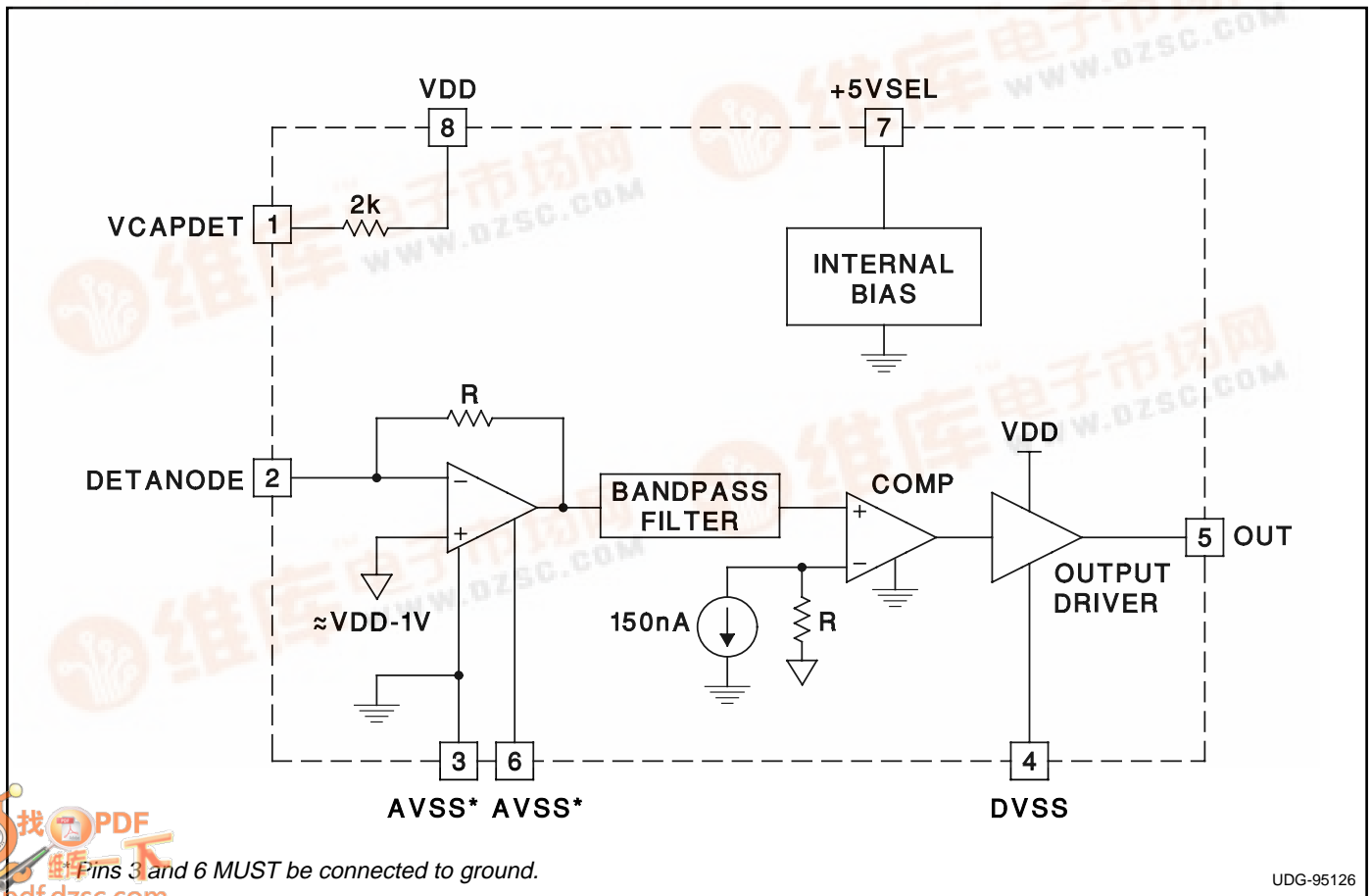

ABSOLUTE MAXIMUM RATINGS

VDD	−0.3V TO +6V
Voltage at +5VSEL (r.t. GND)	−0.3V to VDD
Input Source Current to DETANODE	20mA
Package Power Dissipation	25mW
Operating Temperature Range	0°C to +70°C
Storage Temperature Range	−55°C to +125°C

Currents are positive into, negative out of the specified terminal.
Consult Packaging Section of Databook for thermal limitations and considerations of packages.

RECOMMENDED OPERATING CONDITIONS

VCC Voltage	3.0V to 5.5V
-------------	--------------

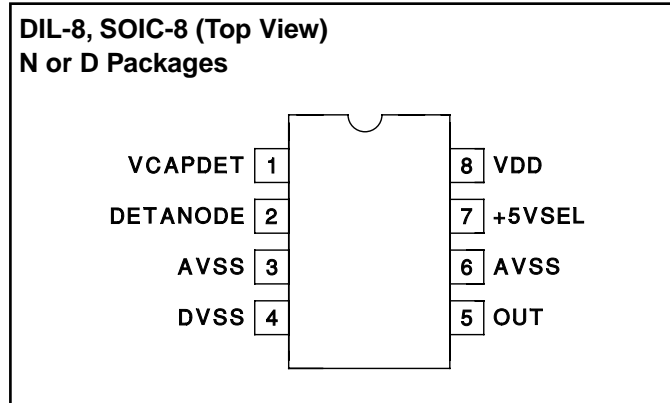
CONNECTION DIAGRAM

ELECTRICAL CHARACTERISTICS Unless otherwise specified, $3.0V \leq VDD \leq 3.5V$ and $+5VSEL = GND$, or $4.5V \leq VDD \leq 5.5V$ and $+5VSEL = VDD$, $C_{DETECTOR} < 56pF$, $C_{LOAD} = 40pF$, $0^\circ C < T_A < 70^\circ C$, $T_A = T_J$.

PARAMETER	TEST CONDITIONS	MIN	TYP	MAX	UNITS
Supply Current, I _{DD}	No Load, I _{DETECTOR} = 1μA		90	150	μA
Detector Decoupling Resistance, R _{DD}			2.0	3.0	kΩ
+5VSEL Input Leakage		−10		10	μA
Detector Amplifier					
I _{PDmax}	VDD = 3V	3	4		mA
	VDD = 5V	5			mA
Input Resistance, R _{IN}	I _{DETECTOR} = 1μA			20	kΩ
Detection Threshold	1μA DC Ambient Background Current		150		nA
Noise Current, I _N (rti)	Bandwidth = 0 to 650kHz			6	nA(rms)
Signal to Noise Ratio	I _{DETECTOR} = 400nA	12			
Lower Bandwidth		20	40		kHz
Upper Bandwidth		0.65	1		MHz
Digital Output					
Output High, V _{OH}	I _{LOAD} = −100μA	2.4			V
Output Low, V _{OL}	I _{LOAD} = 0.8mA			0.4	V
AC Parameters					
Rise Time, T _r			100	200	ns
Fall Time, T _f			100	200	ns
Pulse Width, T _w	T _w , Input = 1.6μs, I _{DETECTOR} = 400nA		2		μs
Pulse Jitter, T _j				200	ns
Pulse Delay, T _d				2	μs

PIN DESCRIPTIONS

+5VSEL: +5 volt selection, strap to DVSS for 3.3 Volt or to +5 Volts for 5 Volt Operation.

AVSS: Analog Ground, VSS.

DETANODE: High side input of the transimpedance amplifier, Photodiode input.

DVSS: Digital Ground, VSS.

OUT: TTL compatible output to the IrDA Compliant UART/Super I/O.

VCAPDET: Low side of the transimpedance amplifier input, Photodiode input. It should be bypassed to AVSS with a 10μF capacitor.

VDD: +5 or +3.3 Volts supply.

APPLICATIONS INFORMATION

TYPICAL APPLICATION

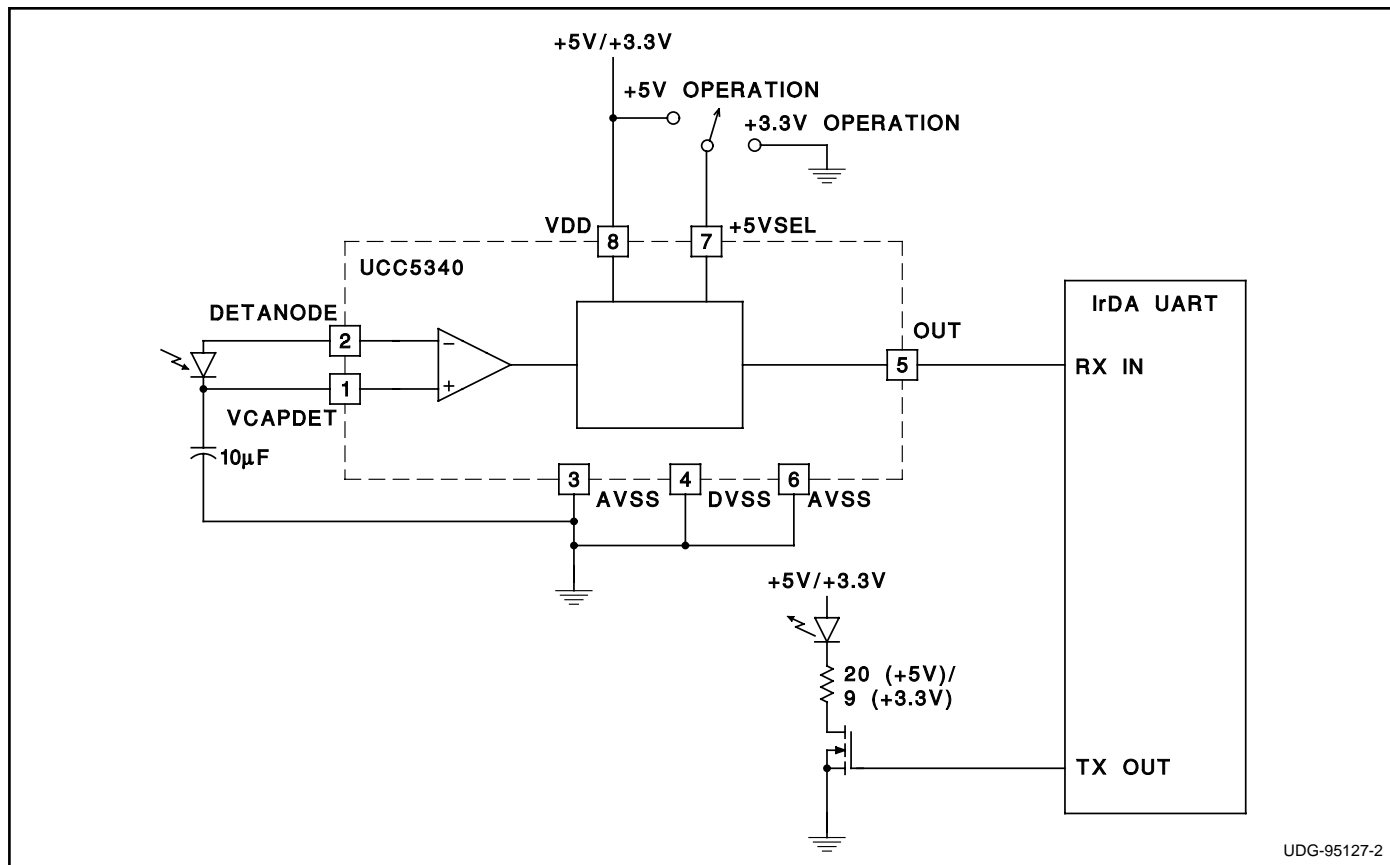

IrDA Character as it Relates to the UART Character

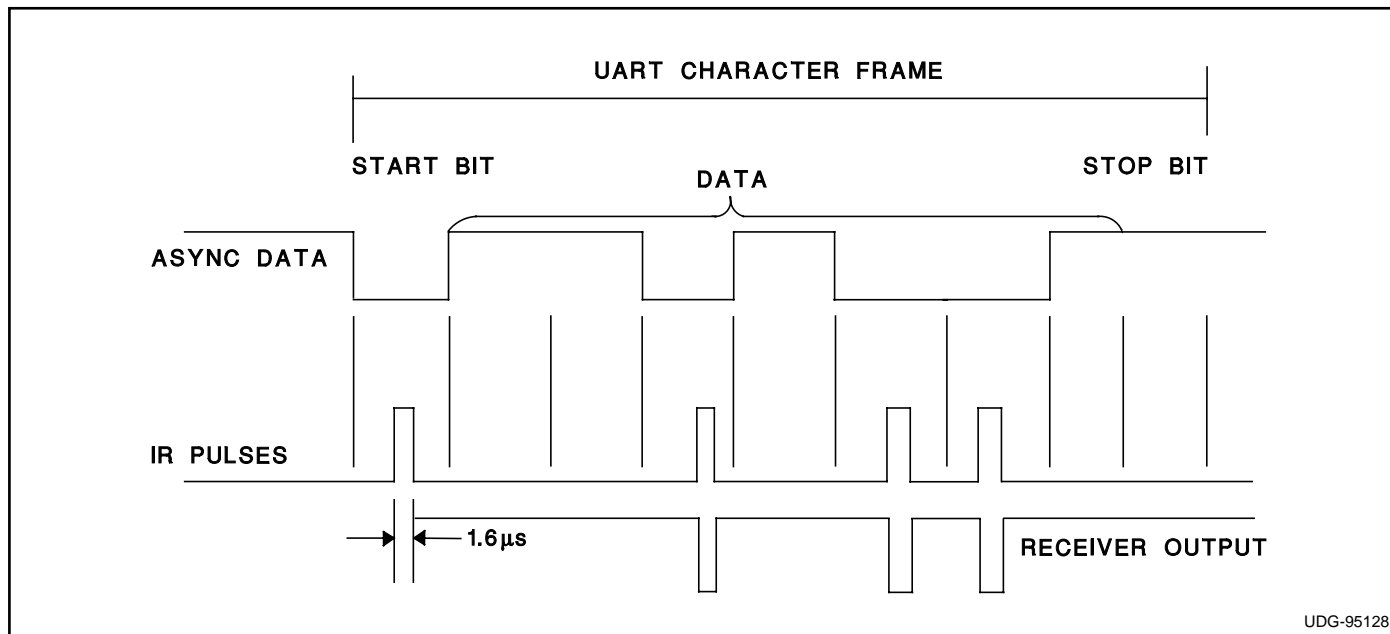

APPLICATIONS INFORMATION (cont.)

The IrDA stream is a 1.6 microsecond or 3/16 th of a bit time pulse for each zero or start bit. The IrDA receiver must pick up the start bit to frame the character.

The start bit must be passed to the UART to start the framing. This is critical to get the Start bit, the IR receiver can not be in saturation from the last information transfered from the system. This requires a fast receiver AGC system, amplifiers, and filters that are not in saturation.

The receiver has to work over a very wide ambient IR level, from sunlit rooms to dark rooms. There is a wide range of background noise and ambient levels that must

be filtered out.

The receiver sees the light from the transmit side which can be at a much higher level than the received signal from another unit. The receiver must come out of saturation fast to recover to pick up the first start bit.

Units that are designed for low power will only use the 1.6 microsecond transmit pulse, others that are not concerned with power may use the 3/16 th of the bit time over the range of 2400, 9600, 19.2k, 38.4k, 57.6k, and 115.2k BPS. The shortest pulse width allowed is 1.41 microseconds, the longest pulse at 2400 BPS is 88.55 microseconds.

IrDA Standard for Speed and Tolerance

Bit Rate	Bit Rate Tolerance	Pulse Width Minimum	Pulse width 3/16 Nominal	Pulse Width Maximum
Kbits/second	% of Bit Rate	microseconds	microseconds	microseconds
2.4	± 0.87	1.41	78.13	88.55
9.6	± 0.87	1.41	19.53	22.13
19.2	± 0.87	1.41	9.77	11.07
38.4	± 0.87	1.41	4.88	5.96
57.6	± 0.87	1.41	3.26	4.34
115.2	± 0.87	1.41	1.63	2.71

APPLICATIONS HINTS

The UCC5340 low pass filter input should be bypassed with a 10µF low ESR tantalum capacitor positioned as close to VCAPDET as possible. Connections to the photodiode input should be short, surrounded by ground, and as direct as possible to reduce stray capacitance and noise pickup. To obtain maximum performance, a sepa-

rate ground plane and metal EMI shield are recommended. The optical port surface of the transmit LED and photodiode should be positioned at least one centimeter away from an IR optical window and equipment case to insure that direct sunlight does not impinge onto the photodiode surface.

IMPORTANT NOTICE

Texas Instruments and its subsidiaries (TI) reserve the right to make changes to their products or to discontinue any product or service without notice, and advise customers to obtain the latest version of relevant information to verify, before placing orders, that information being relied on is current and complete. All products are sold subject to the terms and conditions of sale supplied at the time of order acknowledgment, including those pertaining to warranty, patent infringement, and limitation of liability.

TI warrants performance of its semiconductor products to the specifications applicable at the time of sale in accordance with TI's standard warranty. Testing and other quality control techniques are utilized to the extent TI deems necessary to support this warranty. Specific testing of all parameters of each device is not necessarily performed, except those mandated by government requirements.

Customers are responsible for their applications using TI components.

In order to minimize risks associated with the customer's applications, adequate design and operating safeguards must be provided by the customer to minimize inherent or procedural hazards.

TI assumes no liability for applications assistance or customer product design. TI does not warrant or represent that any license, either express or implied, is granted under any patent right, copyright, mask work right, or other intellectual property right of TI covering or relating to any combination, machine, or process in which such semiconductor products or services might be or are used. TI's publication of information regarding any third party's products or services does not constitute TI's approval, warranty or endorsement thereof.