

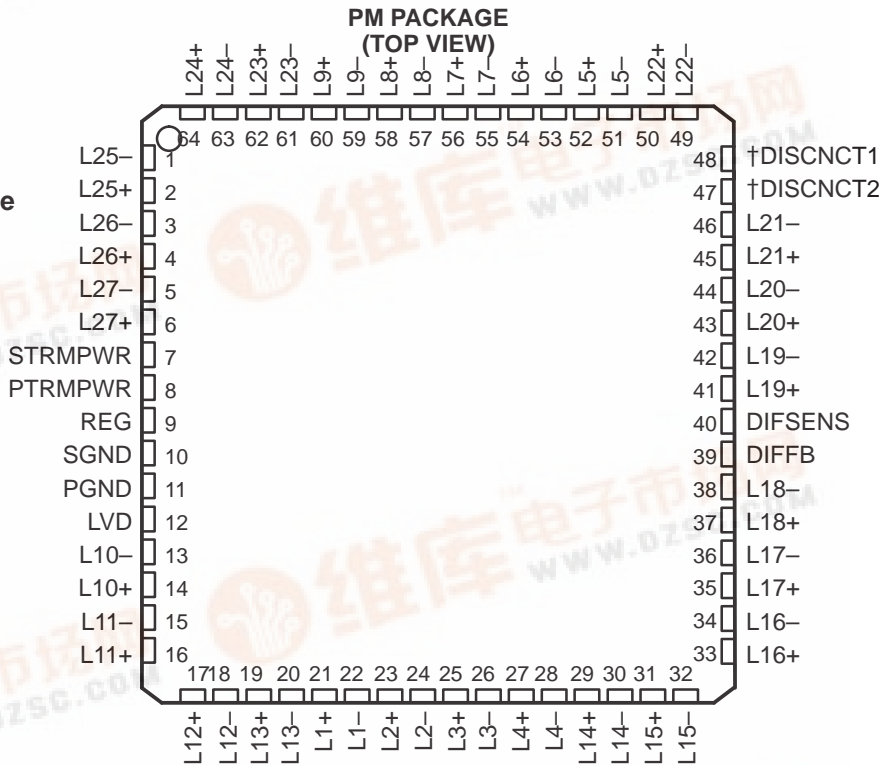

- **SCSI SPI-2, SPI-3, Ultra160 Compliance**
- **Smallest Footprint**
- **Lowest Channel Capacitance, 2 pF**
- **Less than 0.5-pF Capacitance Differential Between Pairs**
- **2.7 V to 5.25 V Operation**
- **Differential Failsafe Bias**
- **64-Pin Low Profile QFP**



description

†For the UCC5647, Pin 47 is DISCNCT1 and Pin 48 is DISCNCT2.

The UCC5646 is a twenty-seven line active terminator for low-voltage-differential (LVD) SCSI networks. This LVD SCSI-only design allows the user to reach peak bus performance, while reducing system cost. The device is designed as an active Y-terminator to improve the frequency response of the LVD SCSI Bus. Designed with a 2-pF (typical) channel capacitance, the UCC5646 allows for minimal bus loading for a maximum number of peripherals. With the UCC5646, the designer is able to comply with the Ultra2, Ultra3, and Ultra160 specifications. The UCC5646 also provides a much-needed system migration path for the ever improving SCSI system standards.

This device is available in the 64-pin low-profile QFP package for ease of layout use.

Single-ended (SE) and high-voltage differential (HVD) SCSI drivers are not supported.

AVAILABLE OPTIONS

TA	DISCONNECT STATUS	PACKAGED DEVICES†
		LOW PROFILE QFP (PM)
0°C to 70°C	REGULAR	UCC5646PM
	REVERSE	UCC5647PM

† The PM package is available taped and reeled. Add TR suffix to device type (e.g. UCC5646PMTR) to order quantities of 1000 devices per reel.

Please be aware that an important notice concerning availability, standard warranty, and use in critical applications of Texas Instruments semiconductor products and disclaimers thereto appears at the end of this data sheet.



UCC5646, UCC5647
27-LINE 3-V – 5-V LVD TERMINATOR
FOR WIDE ULTRA2 AND ULTRA3 SCSI
 SLUS386A – FEBRUARY 2000 – REVISED JUNE 2000

block diagram

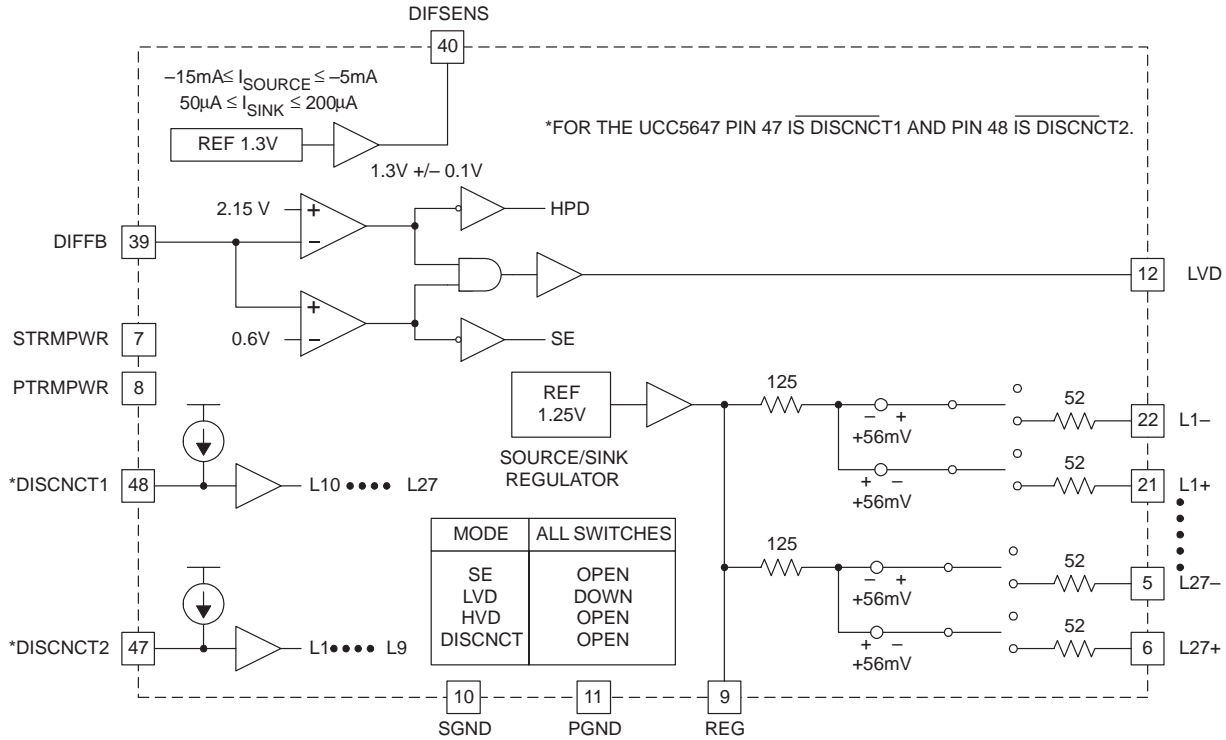

absolute maximum ratings over operating free-air temperature range (unless otherwise noted)†‡

Input voltage V_{IN} (STRMPWR, PTRMPWR)	6 V
Signal line input voltage	0 V to 5 V
Regulator output current	0.75 A
Storage temperature range, T_{stg}	-55°C to 150°C
Operating virtual junction temperature range, T_J	-55°C to 150°C
Lead temperature (soldering, 10 seconds)	300°C

† Stresses beyond those listed under “absolute maximum ratings” may cause permanent damage to the device. These are stress ratings only, and functional operation of the device at these or any other conditions beyond those indicated under “recommended operating conditions” is not implied. Exposure to absolute-maximum-rated conditions for extended periods may affect device reliability.

‡ Unless otherwise indicated, voltages are reference to ground and currents are positive into and negative out of the specified terminals. Consult *Packaging Section* of the Databook for thermal limitations and considerations of packages. All voltages are referenced to GND.

UCC5646, UCC5647
27-LINE 3-V – 5-V LVD TERMINATOR
FOR WIDE ULTRA2 AND ULTRA3 SCSI
 SLUS386A – FEBRUARY 2000 – REVISED JUNE 2000

electrical characteristics over recommended operating free-air temperature range, $xTRMPWR = 2.7\text{ V to }5.25\text{ V}$, $T_A = 0^\circ\text{C to }70^\circ\text{C}$, $DISCNCT1 = DISCNCT2 = 0\text{ V}$ for UCC5646, $DISCNCT1 = DISCNCT2 = \text{open}$ for UCC5647, $T_A = T_J$. (unless otherwise noted)

PARAMETER	TEST CONDITIONS	MIN	TYP	MAX	UNIT
xTRMPWR Supply Current Section					
xTRMPWR supply current	LVD mode			65	mA
	Disabled terminator			500	μA
1.25 V Regulator Section					
1.25 V regulator	$0.5\text{ V} \leq V_{CM} \leq 2.0\text{ V}$, See Note 1	1.15	1.25	1.35	V
Regulator source current	$V_{REG} = 0\text{ V}$		-300	-240	mA
Regulator sink current	$V_{REG} = 3.0\text{ V}$	240	300		mA
1.3 V (DIFSENS) Regulator Section					
1.3 V regulator	$-5\text{ mA} \leq I_{DIFSENS} \leq 50\text{ }\mu\text{A}$	1.2	1.3	1.4	V
Short-circuit source current	$V_{DIFSENS} = 0\text{ V}$	-5	-8	-15	mA
Short-circuit sink current	$V_{DIFSENS} = 2.75\text{ V}$	50		200	μA
Differential Termination Section (Applies to each line pair 1–27)					
Differential bias voltage		100		125	mV
Differential impedance		100	105	110	Ω
Common-mode bias voltage	L+ and L– shorted together	1.15	1.25	1.35	V
Common-mode impedance	L+ and L– shorted together, See Note 2	110	140	165	Ω
Disconnected Termination Section					
Output leakage current			10	400	nA
Output capacitance	SE measurement to GND, See Note 3			3	pF
Disconnect Control (DISCNCT1) or (DISCNCT2) and DIFFB Input Section					
DISCNCT threshold voltage		0.8	1.5	2.0	V
DISCNCT input current	$V_{DISCNCT} = 0\text{ V and }2.0\text{ V}$	-30		-10	μA
DIFFB SE to LVD threshold voltage		0.5	0.6	0.7	V
DIFFB LVD to HPD threshold voltage		1.9	2.05	2.2	V
DIFFB Input current	$0\text{ V} \leq V_{DIFFB} \leq 2.75\text{ V}$,	-10		10	μA
Low-Voltage Differential (LVD) Status Bit Section					
Source current	$V_{LOAD} = 2.4\text{ V}$		-6	-4	mA
Sink current	$V_{LOAD} = 0.4\text{ V}$	2	5		mA
Thermal Shutdown Section					
Thermal shutdown threshold	For increasing temperature	140	155	170	$^\circ\text{C}$
Thermal shutdown hysteresis			10		$^\circ\text{C}$

NOTE 1: V_{CM} is applied to all L+ and L– lines simultaneously.

NOTE 2: $Z_{CM} = \frac{2.0\text{ V} - 0.5\text{ V}}{I_{VCM(max)} - I_{VCM(max)}}$, $V_{CM(max)} = 2.0\text{ V}$, $V_{CM(min)} = 0.5\text{ V}$

NOTE 3: Ensured by design, not production tested.

UCC5646, UCC5647
27-LINE 3-V – 5-V LVD TERMINATOR
FOR WIDE ULTRA2 AND ULTRA3 SCSI
SLUS386A – FEBRUARY 2000 – REVISED JUNE 2000

pin descriptions

STRMPWR: 2.7 V to 5.25 V power supply for all circuitry except the 1.25-V regulator.

SGND: Ground reference for all circuitry except the 1.25-V regulator.

PTRMPWR: 2.7 V to 5.25 V power supply for the 1.25-V regulator.

PGND: Ground reference for the 1.25-V regulator.

REG: Output of the internal 1.25-V regulator; must be connected to a 4.7- μ F bypass capacitor and a high-frequency, low-ESR 0.01- μ F capacitor to GND.

DIFSENS: Drives the SCSI bus DIFF SENSE line to 1.3 V to detect what types of devices are tied to the bus.

DIFFB: DIFF SENSE input pin. Connect through a 20-k Ω resistor to DIFSENS and through a 0.1- μ F capacitor to GND. Input to comparators that detect what type of drives are connected to the SCSI bus.

DISCNCT1: Disconnect one controls termination lines 10–27 (control and low byte).

DISCNCT2: Disconnect two controls termination lines 1–9 (high byte).

LVD: TTL compatible status bit indicating when low-voltage-differential voltage is present on DIFFB.

L1– thru L27–: Negative lines for the SCSI bus.

L1+ thru L27+: Positive lines for the SCSI bus.

UCC5646, UCC5647
27-LINE 3-V - 5-V LVD TERMINATOR
FOR WIDE ULTRA2 AND ULTRA3 SCSI
 SLUS386A - FEBRUARY 2000 - REVISED JUNE 2000

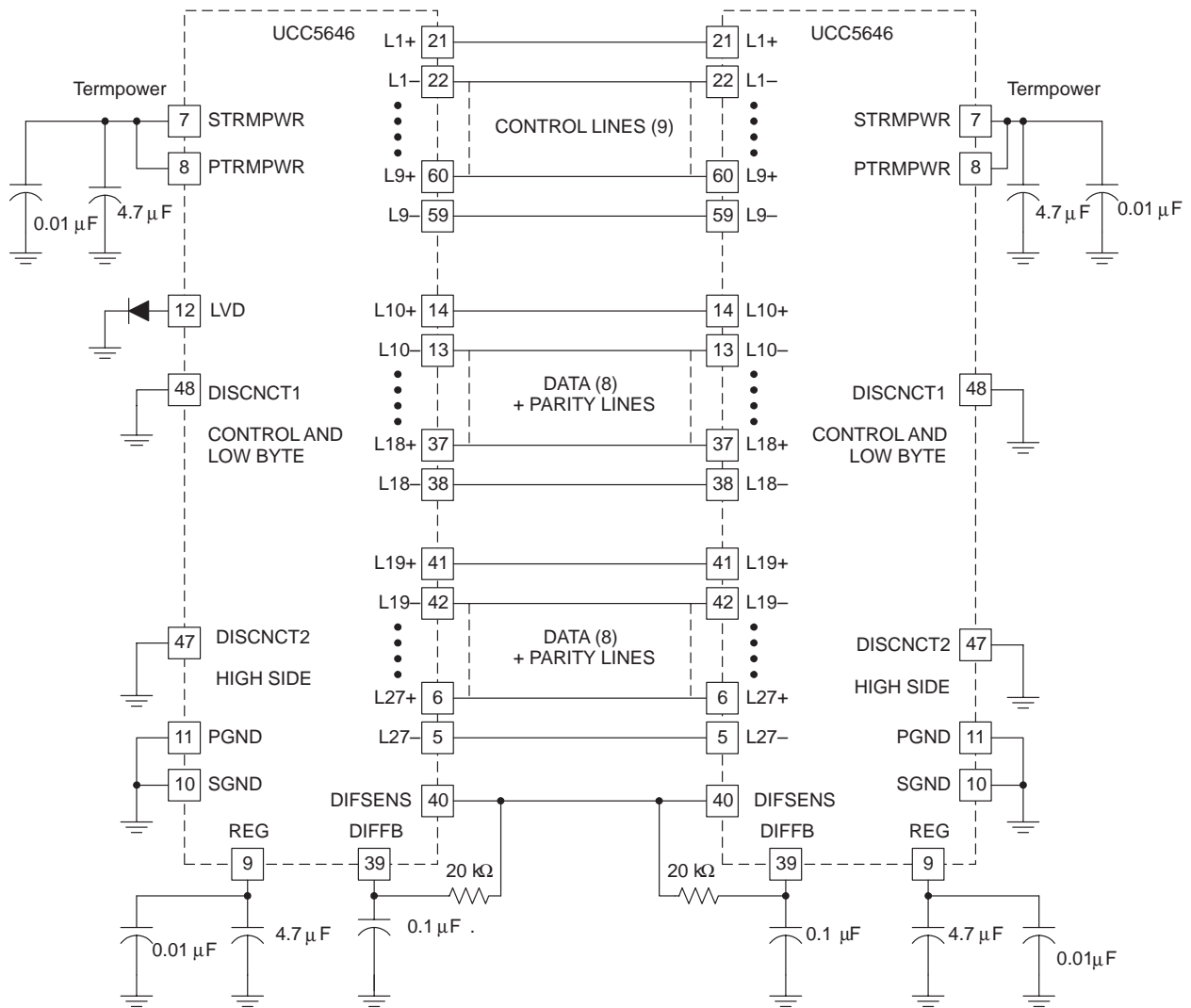

Figure 1. Typical Application Diagram

IMPORTANT NOTICE

Texas Instruments and its subsidiaries (TI) reserve the right to make changes to their products or to discontinue any product or service without notice, and advise customers to obtain the latest version of relevant information to verify, before placing orders, that information being relied on is current and complete. All products are sold subject to the terms and conditions of sale supplied at the time of order acknowledgment, including those pertaining to warranty, patent infringement, and limitation of liability.

TI warrants performance of its semiconductor products to the specifications applicable at the time of sale in accordance with TI's standard warranty. Testing and other quality control techniques are utilized to the extent TI deems necessary to support this warranty. Specific testing of all parameters of each device is not necessarily performed, except those mandated by government requirements.

Customers are responsible for their applications using TI components.

In order to minimize risks associated with the customer's applications, adequate design and operating safeguards must be provided by the customer to minimize inherent or procedural hazards.

TI assumes no liability for applications assistance or customer product design. TI does not warrant or represent that any license, either express or implied, is granted under any patent right, copyright, mask work right, or other intellectual property right of TI covering or relating to any combination, machine, or process in which such semiconductor products or services might be or are used. TI's publication of information regarding any third party's products or services does not constitute TI's approval, warranty or endorsement thereof.