

THS8133A THS8133A TRIPLE 10-BIT, 80 MSPS VIDEO D/A CONVERTER WITH TRI-LEVEL SYNC GENERATION

SLVS204B – APRIL 1999 – REVISED OCTOBER 1999

features

- Triple 10-bit D/A Converters
- Minimum 80 MSPS Operation
- Direct Drive of Doubly-Terminated 75-Ω Load Into Standard Video Levels
- 3×10 Bit 4:4:4, 2×10 Bit 4:2:2 or 1×10 Bit 4:2:2 (ITU-BT.656) Multiplexed YPbPr/GBR Input Modes
- Bi-Level (EIA) or Tri-Level (SMPTE) Sync Generation With 7:3 Video/Sync Ratio
- Integrated Insertion of Sync-On-Green/Luminance or Sync-On-All Channels
- Configurable Blanking Level
- Internal Voltage Reference

applications

- High-Definition Television (HDTV) Set-Top Boxes/Receivers
- High-Resolution Image Processing
- Desktop Publishing
- Direct Digital Synthesis/I-Q Modulation

TQFP-48 PowerPAD™ PACKAGE
(TOP VIEW)

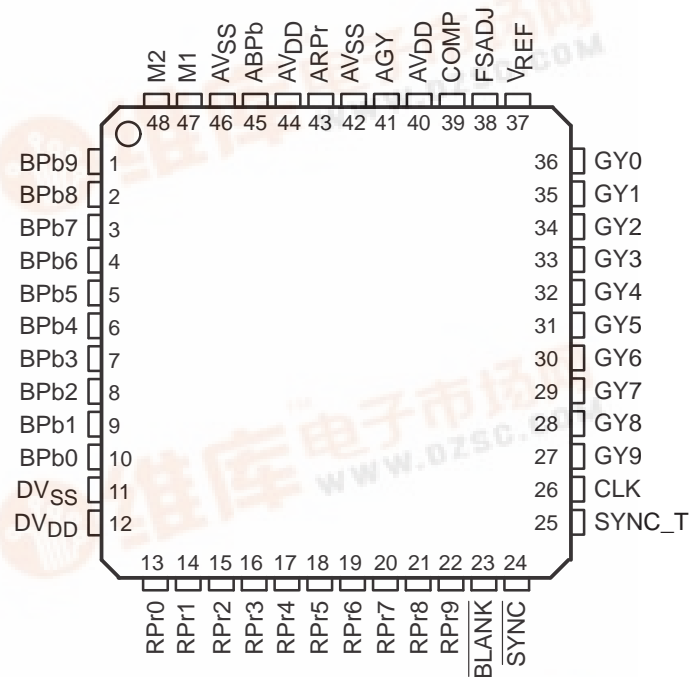

See ALSO: THS8134 (8 bit, pin-compatible)

description

The THS8133 is a general-purpose triple high-speed D/A converter (DAC) optimized for use in video/graphics applications. The device operates from a 5-V analog supply and a 3-V to 5-V range digital supply. The THS8133 has a sampling rate up to 80 MSPS. The device consists of three 10-bit D/A converters and additional circuitry for bi-level/tri-level sync and blanking level generation in video applications.

THS8133 is also well suited in applications where multiple well-matched and synchronously operating DACs are needed; for example, I-Q modulation and direct-digital synthesis in communications equipment.

The current-steering DACs can be directly terminated in resistive loads to produce voltage outputs. The device provides a flexible configuration of maximum output current drive. Its output drivers are specifically designed to produce standard video output levels when directly connected to a single-ended doubly-terminated 75 Ω coaxial cable. Full-scale video/sync are generated in a 7:3 ratio, compliant with SMPTE standards for GBR and YPbPr signals.

Furthermore, the THS8133 can generate both a traditional bi-level sync or a tri-level sync signal, as per the SMPTE standards, via a digital control interface. The sync signal is inserted on one of the analog output channels (sync-on-green/luminance) or on all output channels. Also, a blanking control signal sets the outputs to defined levels during the nonactive video window.

Finally the input format can be either 3×10 bit 4:4:4, 2×10 bit 4:2:2, or 1×10 bit 4:2:2. This enables a direct interface to a wide range of video DSP/ASICs including parts generating ITU-BT.656 formatted output data.

Please be aware that an important notice concerning availability, standard warranty, and use in critical applications of Texas Instruments semiconductor products and disclaimers thereto appears at the end of this data sheet.

PowerPAD is a trademark of Texas Instruments Incorporated.

PRODUCTION DATA information is current as of publication date. Products conform to specifications per the terms of Texas Instruments standard warranty. Production processing does not necessarily include testing of all parameters.

Copyright © 1999, Texas Instruments Incorporated

THS8133, THS8133A

TRIPLE 10-BIT, 80 MSPS VIDEO D/A CONVERTER

WITH TRI-LEVEL SYNC GENERATION

SLVS204B – APRIL 1999 – REVISED OCTOBER 1999

AVAILABLE OPTIONS

T _A	PACKAGE
	TQFP-48 PowerPAD
0°C to 70°C	THS8133CPHP
	THS8133ACPHP†

† The imbalance between DACs applies to all possible pairs of the three DACs. K_{IMBAL} is assured over full temperature range. In parts labeled THS8133CPHP, K_{IMBAL}(SYNC) is assured at 25°C. In parts labeled THS8133ACPHP, K_{IMBAL}(SYNC) is assured over the full temperature range.

Terminal Functions

TERMINAL NAME	PIN	I/O	DESCRIPTION
ABPb	45	O	Analog red, green and blue respectively Pr, Y and Pb current outputs, capable of directly driving a doubly terminated 75-Ω coaxial cable.
AGY	41	O	
ARPr	43	O	
AV _{DD}	40,44	I	Analog power supply (5 V ±10%). All AV _{DD} terminals must be connected.
AV _{SS}	42,46	I	Analog ground
BLANK	23	I	Blanking control input, active low. A rising edge on CLK latches BLANK. When asserted, the ARPr, AGY and ABPb outputs are driven to the blanking level, irrespective of the value on the data inputs. SYNC takes precedence over BLANK, so asserting SYNC (low) while BLANK is active (low) will result in sync generation.
BPb0–BPb9	10–1	I	Blue or Pb pixel data input bus. Index 0 denotes the least significant bit. Refer to functional description for different operating modes.
CLK	26	I	Clock input. A rising edge on CLK latches RPr0-9, GY0-9, BPb0-9, BLANK, SYNC, and SYNC_T. The M2 input is latched by a rising edge on CLK also, but only when additional conditions are satisfied, as explained in its terminal description.
COMP	39	O	Compensation terminal. A 0.1 μF capacitor must be connected between COMP and AV _{DD} .
DV _{DD}	12	I	Digital power supply (3-V to 5-V range)
DV _{SS}	11	I	Digital ground
FSADJ	38	I	Full-scale adjust control. The full-scale current drive on each of the output channels is determined by the value of a resistor R _{FS} connected between this terminal and AV _{SS} . The nominal value of R _{FS} is 430 Ω, corresponding to 26.67 mA full-scale current. The relationship between R _{FS} and the full-scale current level for each operation mode is explained in the functional description.
GY0–GY9	36–27	I	Green or Y pixel data input bus. Index 0 denotes the least significant bit. Refer to functional description for different operating modes.
M1	47	I	Operation mode control 1. M1 is directly interpreted by the device (it is not latched by CLK). M1 configures device according to Table 1.
M2	48	I	Operation mode control 2. The second rising edge on CLK after a transition on SYNC latches M2. The interpretation is dependent on the polarity of the last SYNC transition: SYNC L to H: latched as M2_INT SYNC H to L: latched as INS3_INT Together with M1, M2_INT configures the device as shown in Table 1. When INS3_INT is high, the sync output is inserted on all DAC outputs; a low will insert it only on the AGY output. See also Figure 2 and Table 2. The value of M2 at powerup is undetermined. Therefore at least 1 L →H transition on SYNC is required to set M2.
RPr0–RPr9	13–22	I	Red or Pr pixel data input bus. Index 0 denotes the least significant bit. Refer to functional description for different operating modes.
SYNC	24	I	Sync control input, active low. A rising edge on CLK latches SYNC. When asserted, only the AGY output (INS3_INT=L, see terminal M2) or ARPr, AGY and ABPb outputs (INS3_INT=H, see terminal M2) are driven to the sync level, irrespective of the values on the data or BLANK inputs. Consequently, SYNC should remain low for the whole duration of sync, which is in the case of a tri-level sync both the negative and positive portion (see Figure 7).

THS8133, THS8133A
TRIPLE 10-BIT, 80 MSPS VIDEO D/A CONVERTER
WITH TRI-LEVEL SYNC GENERATION
 SLVS204B – APRIL 1999 – REVISED OCTOBER 1999

Terminal Functions (Continued)

TERMINAL NAME	PIN	I/O	DESCRIPTION
SYNC_T	25	I	Sync tri-level control, active high. A rising edge on CLK latches SYNC_T. When asserted, a positive sync (higher than blanking level) is generated when SYNC is low. When disabled, a negative sync (lower than blanking level) is generated when SYNC is low. When generating a tri-level (negative-to-positive) sync, a L → H transition on this signal positions the start of the positive transition. See Figure 6 for timing control. The value on SYNC_T is ignored when SYNC is not asserted (high).
VREF	37	I/O	Voltage reference for DACs. An internal voltage reference of nominally 1.35 V is provided, which requires an external 0.1 μF ceramic capacitor between VREF and AVSS. However, the internal reference can be overdriven by an externally supplied reference voltage.

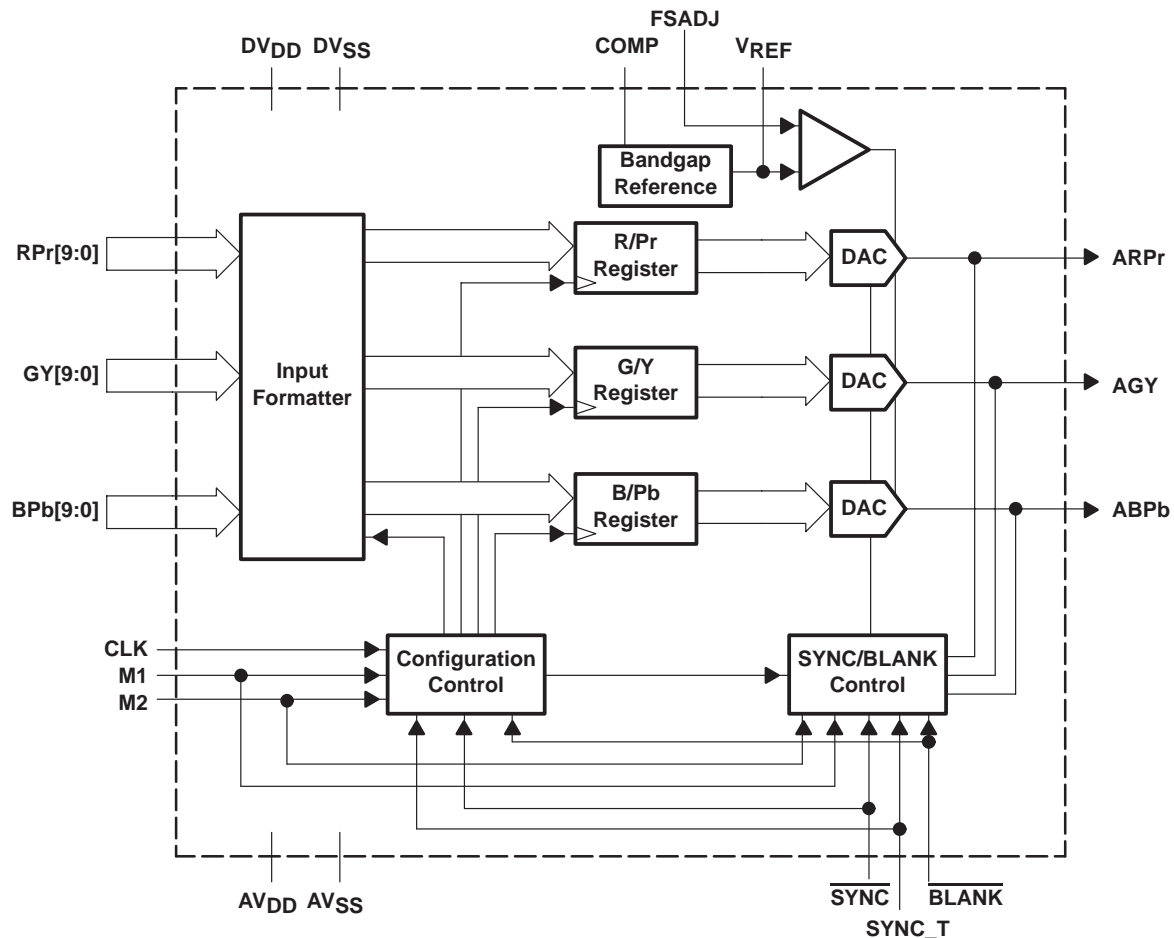

Figure 1. THS8133 Block Diagram

functional description

device configuration

Input data to the device can be supplied from a 3x10b GBR/YPbPr input port. If the device is configured to take data from all three channels, the data is clocked in at each rising edge of CLK. All three DACs operate at the full clock speed of CLK.

THS8133, THS8133A

TRIPLE 10-BIT, 80 MSPS VIDEO D/A CONVERTER

WITH TRI-LEVEL SYNC GENERATION

SLVS204B – APRIL 1999 – REVISED OCTOBER 1999

device configuration (continued)

In the case of 4:2:2 sampled data (for YPbPr) the device can be fed over either a 2x10 bit or 1x10 bit multiplexed input port. An internal demultiplexer will route input samples to the appropriate DAC: Y at the rate of CLK, Pb and Pr each at rate of one-half CLK.

According to ITU-BT.656 the sample sequence is Pb-Y-Pr over a 1x10 bit interface (Y-port). The sample sequence starts at the first rising edge of CLK after $\overline{\text{BLANK}}$ has been taken high (inactive). In this case the frequency of CLK is two times the Y conversion speed and four times the conversion speed of both Pr and Pb.

With a 2x10 bit input interface, both the Y-port and the Pr-port are sampled on every CLK rising edge. The Pr-port carries the sample sequence Pb-Pr. The sample sequence starts at the first rising edge of CLK after $\overline{\text{BLANK}}$ has been taken high (inactive). In this case the frequency of CLK is equal to the conversion speed of Y and 2x the conversion speed of both Pr and Pb.

The device's operation mode is set by the M1 and M2 mode selection terminals, according to Table 1. The operation mode also determines the blanking level, as explained below in the sync/blanking generation sections.

Table 1. THS8133 Configuration

M1	M2_INT†	CONFIGURATION	DESCRIPTION
L	L	GBR 3x10b-4:4:4	GBR mode 4:4:4. Data clocked in on each rising edge of CLK from G, B, and R input channels. Blanking level corresponds to input code 0 of the DAC on all output channels.
L	H	YPbPr 3x10b-4:4:4	YPbPr mode 4:4:4. Data clocked in on each rising edge of CLK from Y, Pb and Pr input channels. Blanking level corresponds to input code 0 of the DAC on the AGY channel and to input code 512 of the DAC on the ABPb and ARPr channels when sync is inserted on all three channels (INS3_INT=H) (see Note 1).
H	L	YPbPr 2x10b-4:2:2	YPbPr mode 4:2:2 2x10 bit. Data clocked in on each rising edge of CLK from Y & Pr input channels. A sample sequence of Pb-Pr-... should be applied to the Pr port. At the first rising edge of CLK after $\overline{\text{BLANK}}$ is taken high, Pb should be present on this port. Blanking level corresponds to input code 0 of the DAC on the AGY channel and to input code 512 of the DAC on the ABPr and ARPb channels (see Note 1).
H	H	YPbPr 1x10b-4:2:2	YPbPr mode 4:2:2 1x10 bit (ITU-BT.656 compliant). Data clocked in on each rising edge of CLK from Y input channel. Blanking level corresponds to input code 0 of the DAC on the AGY channel and to input code 512 of the DAC on the ABPb and ARPr channels when sync is inserted on all three channels (INS3_INT=H) (see Note 1).

† M2_INT is the logic level on M2 registered on the second rising CLK edge after a L → H transition on SYNC, as explained in Table 2.

NOTE 1: When sync is inserted on only the Y channel (INS3_INT=L), blanking level corresponds to input code 0 on all channels.

Table 2. INS3_INT/M2_INT Selection on M2

LAST EVENT ON SYNC	SYNC_T	M1	M2 (see Note 2)	DESCRIPTION
H→L	L or H	X	INS3_INT	Sync Insertion Active: $\overline{\text{SYNC}}$ low enables sync generation on 1 (INS3_INT=L) or all 3 (INS3_INT=H) DAC outputs. SYNC_T determines the sync polarity.
L→H	X	X	M2_INT	Device mode programming active: The DAC outputs reflect the DAC inputs ($\overline{\text{BLANK}}=H$) or are forced to the blanking level ($\overline{\text{BLANK}}=L$). M2 is interpreted according to Table 1.

X = don't care

NOTE 2: M1 and M2 start configuring the device as soon as they are interpreted, which is continuously for M1 (static pin) or on the second rising edge on CLK after a transition on SYNC for M2. M2 is interpreted as either INS3_INT or M2_INT, as shown in Table 2.

programming example

Configuration of the device will normally be static in a given application. If M2_INT and INS3_INT need to be both low or high, the M2 pin is simply tied low or high. If M2_INT and INS3_INT need to have different levels, these can be easily derived from the signal on the SYNC pin, as shown in Table 3 and Figure 2.

Table 3. Generating M2 From SYNC

In order to have:		Apply to M2:
M2_INT	INS3_INT	
L	H	... $\overline{\text{SYNC}}$ delayed by 2 CLK periods
H	L	...inverted $\overline{\text{SYNC}}$ delayed by 2 CLK periods

The input formats and latencies are shown in Figures 3–5 for each operation mode.

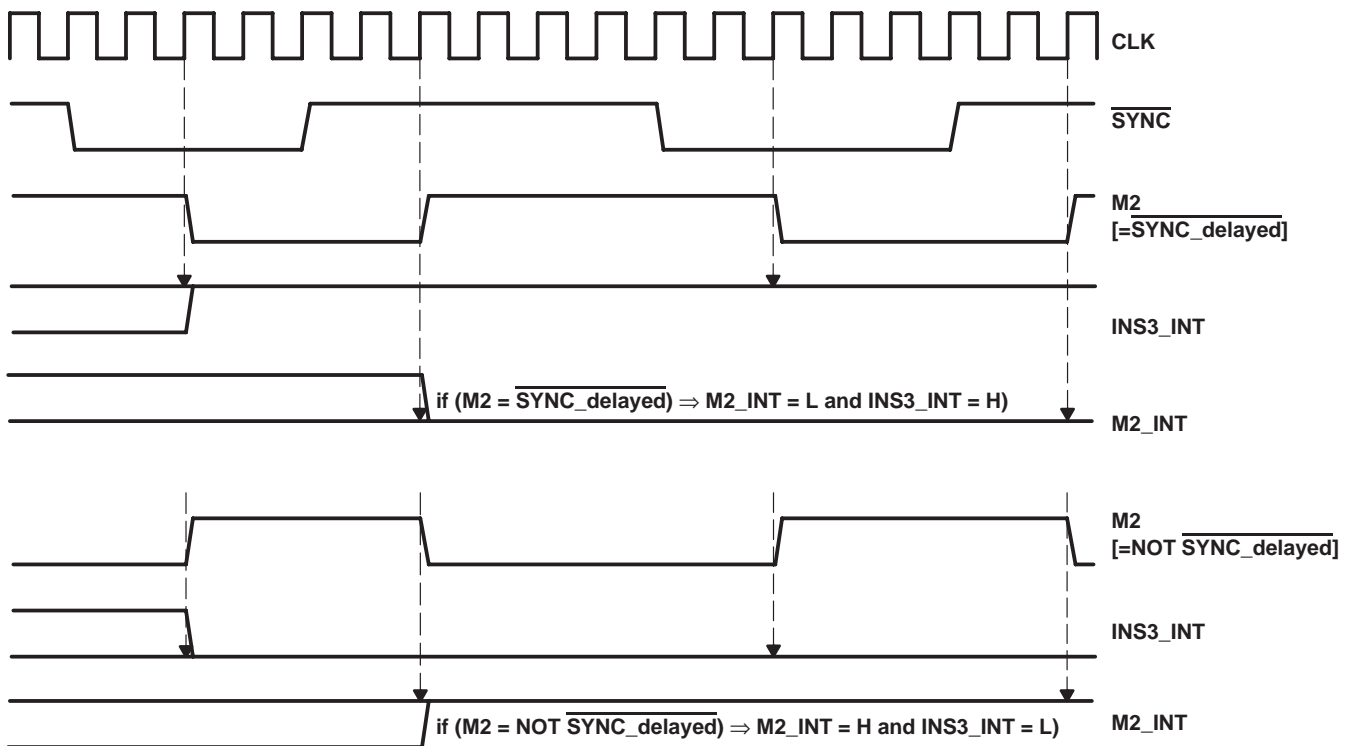

Figure 2. Generating INS3_INT and M2_INT from M2

THS8133, THS8133A TRIPLE 10-BIT, 80 MSPS VIDEO D/A CONVERTER WITH TRI-LEVEL SYNC GENERATION

SLVS204B – APRIL 1999 – REVISED OCTOBER 1999

programming example (continued)

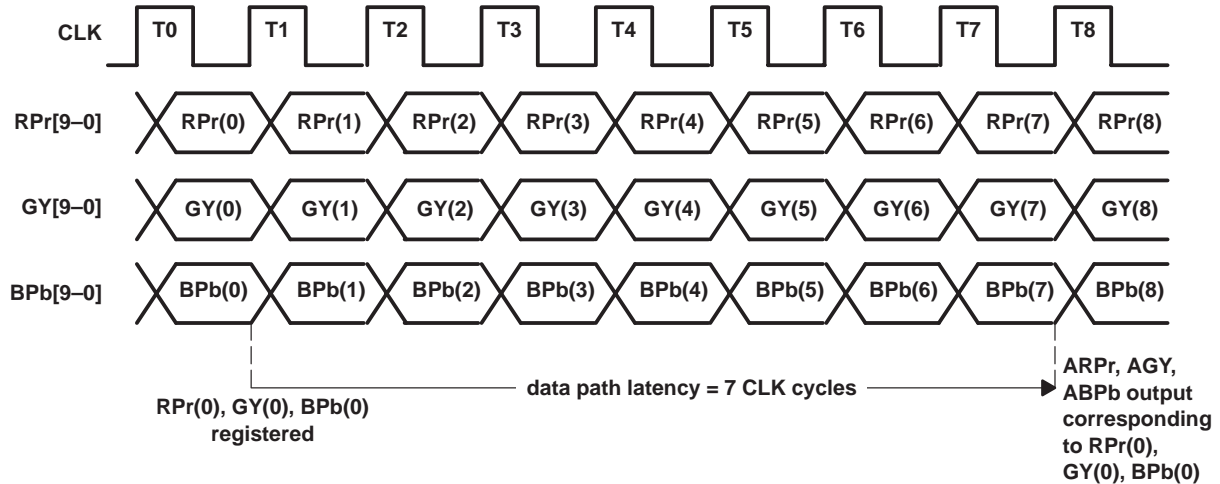

Figure 3. Input Format and Latency YPbPr 4:4:4 and GBR 4:4:4 Modes

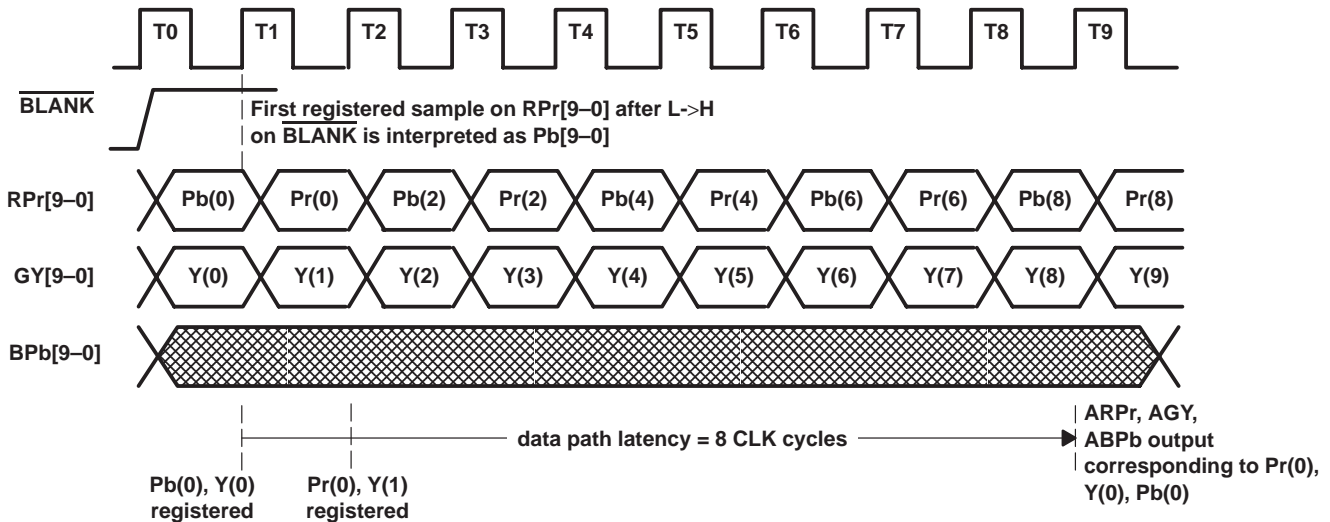

Figure 4. Input Format and Latency YPbPr 4:2:2 2x10 Bit Mode

programming example (continued)

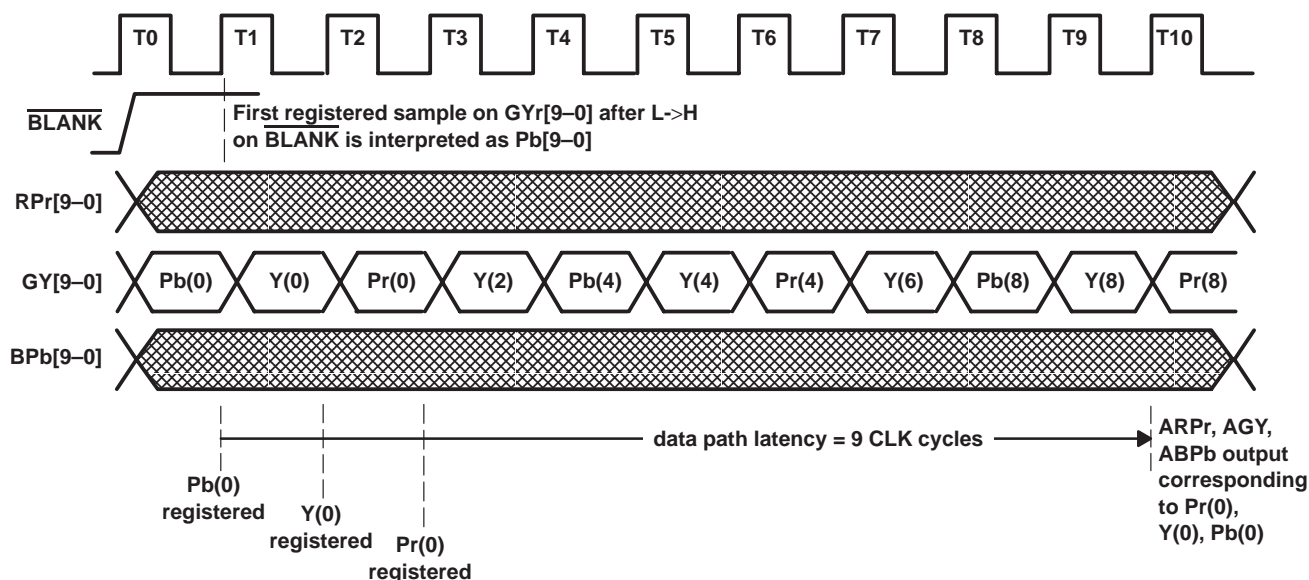

Figure 5. Input Format and Latency YPbPr 4:2:2 1×10 Bit Mode

sync generation

Additional control inputs $\overline{\text{SYNC}}$ and SYNC_T enable the superposition of an additional current onto the AGY channel or on all three channels, depending on the setting of INS3_INT. By combining the $\overline{\text{SYNC}}$ and SYNC_T control inputs, either bi-level negative going pulses or tri-level pulses can be generated. Depending on the timing controls for these signals, both horizontal and vertical sync signals can be generated. Assertion of $\overline{\text{SYNC}}$ (active low) will identify the sync period, while assertion of SYNC_T (active high) within this period will identify the positive excursion of a tri-level sync.

Refer to the application information section for practical examples on the use of these control inputs for sync generation.

blanking generation

An additional control input $\overline{\text{BLANK}}$ is provided that will fix the output amplitude on all channels to the blanking level, irrespective of the value on the data input ports. However, sync generation has precedence over blanking; that is, if $\overline{\text{SYNC}}$ is low, the level of $\overline{\text{BLANK}}$ is *don't care*. The absolute amplitude of the blanking level with respect to active video is determined by the GBR or YPbPr operation mode of the device. Refer to the application information section for practical examples on the use of this control input for blank generation.

Figure 6 shows how to control $\overline{\text{SYNC}}$, SYNC_T, and $\overline{\text{BLANK}}$ signals to generate tri-level sync levels and blanking at the DAC output. A bi-level (negative) sync is generated similarly by avoiding the positive transition on SYNC_T during $\overline{\text{SYNC}}$ low.

THS8133, THS8133A TRIPLE 10-BIT, 80 MSPS VIDEO D/A CONVERTER WITH TRI-LEVEL SYNC GENERATION

SLVS204B – APRIL 1999 – REVISED OCTOBER 1999

blanking generation (continued)

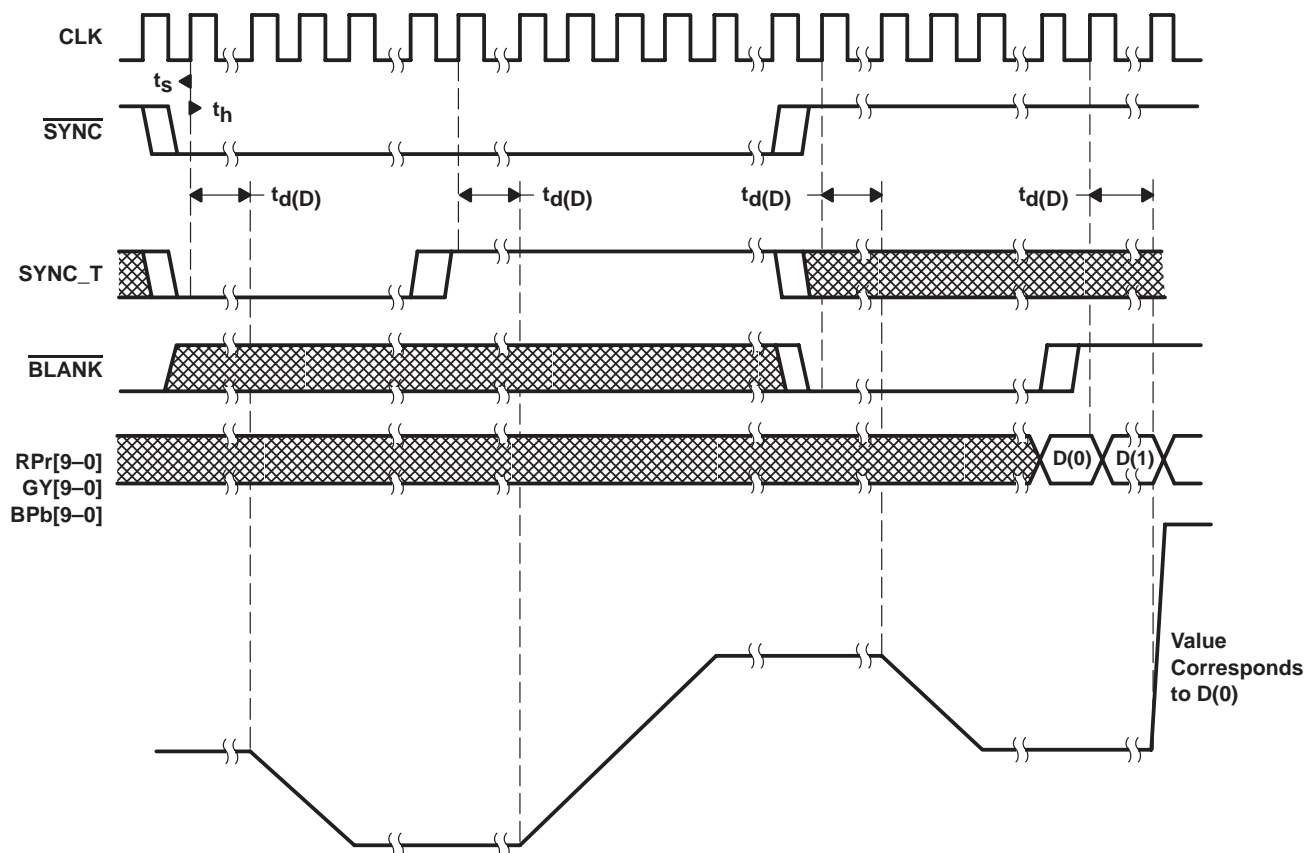

Figure 6. Sync and Blanking Generation

DAC operation

The analog output drivers generate a current of which the drive level can be user-modified by choice of an appropriate resistor value R_{FS} , connected to the FSADJ terminal. Refer to the paragraph on output amplitude control for details on how the output drive is affected by the operation mode of the device.

All current sources derive their amplitudes from an internal generator that produces a 1.35 V reference level. All current source amplitudes (video, blanking, sync) also come from this reference so that the relative amplitudes of sync/blank/video are always equal to their nominal relationships. For increased stability on the absolute levels, the user can overdrive the reference by directly driving the V_{REF} input terminal.

output amplitude control

The current drive on all three output channels and on the internal sync generator is controlled by a resistor R_{FS} that must be connected between FSADJ and AV_{SS} . In all operation modes the relative amplitudes of the current drivers are maintained irrespective of the R_{FS} value, as long as a maximum current drive capability is not exceeded.

The sync generator is composed of different current sources that are internally routed to a corresponding DAC output. Depending on the setting of $INS3_INT$ during \overline{SYNC} low, the sync current drive is added to either only the green channel output (sync-on-green) if $INS3_INT = L$ or all three channel outputs $INS3_INT = H$. In either case the relative current levels, as defined below, are maintained.

THS8133, THS8133A

TRIPLE 10-BIT, 80 MSPS VIDEO D/A CONVERTER WITH TRI-LEVEL SYNC GENERATION

SLVS204B – APRIL 1999 – REVISED OCTOBER 1999

output amplitude control (continued)

The exact relationship between R_{FS} and the current drive level on each channel is dependent on the operation mode of the device (see Table 4). In GBR mode, the output drive is identical on the three channels, while in YPbPr mode, a level shift is implemented on Pb and Pr channels. Refer to the application information section for details on the current drive levels in each mode.

The device has an internal voltage reference derived from a bandgap reference of 1.35 V. The relationship between the full-scale current drive level and R_{FS} is given by:

$$I_{FS} [A] = \alpha \times V_{REF} [V] \div R_{FS} [\Omega]$$

where α is dependent on the operation mode of the device.

Typical operation modes are shown in Table 4 for the nominal R_{FS} value. This value will produce the full-scale current levels mentioned in Table 4 and, when terminated, voltages of standard video levels, as shown in the applications section. The resistor value is variable provided the maximum current level on each of the DAC outputs is not exceeded.

Table 4. THS8133 Nominal Full-Scale Currents

OPERATION MODE DESCRIPTION	M1	M2_INT	INS3_INT	AGY		ARPr		ABPb	
				I_{FS} (mA)	α	I_{FS} (mA)	α	I_{FS} (mA)	α
GBR with sync-on-green	L	L	L	26.67 [†]	1461/172	18.67 [‡]	1023/172	18.67	1023/172
GBR with sync-on-all	L	L	H	26.67	1461/172	26.67	1461/172	26.67	1461/172
YPbPr with sync-on-Y	(L,H), (H,L) or (HH), according to Tables 1 and 2		L	26.67	1461/172	18.67	1023/172	18.67	1023/172
YPbPr with sync-on-all			H	26.67	1461/172	18.67	1023/172	18.67	1023/172

[†] $I_{FS} = 1461/172 \times 1.35/430$

[‡] $I_{FS} = 1023/172 \times 1.35/430$

absolute maximum ratings over operating free-air temperature (unless otherwise noted)[†]

Supply voltage: AV_{DD} to AV_{SS} , DV_{DD} to DV_{SS}	-0.5 V to 7 V
AV_{DD} to DV_{DD} , AV_{SS} to DV_{SS}	-0.5 V to 0.5 V
Digital input voltage range to DV_{SS}	-0.5 V to $DV_{DD} + 0.5$ V
Operating free-air temperature range, T_A	0°C to 70°C
Storage temperature range, T_{stg}	-55°C to 150°C

[†] Stresses beyond those listed under “absolute maximum ratings” may cause permanent damage to the device. These are stress ratings only, and functional operation of the device at these or any other conditions beyond those indicated under “recommended operating conditions” is not implied. Exposure to absolute-maximum-rated conditions for extended periods may affect device reliability.

recommended operating conditions over operating free-air temperature range, T_A

power supply

		MIN	NOM	MAX	UNIT
Supply voltage	AV_{DD}	4.75	5	5.25	V
	DV_{DD}	3	3.3/5	5.25	

THS8133, THS8133A

TRIPLE 10-BIT, 80 MSPS VIDEO D/A CONVERTER

WITH TRI-LEVEL SYNC GENERATION

SLVS204B – APRIL 1999 – REVISED OCTOBER 1999

recommended operating conditions over operating free-air temperature range, T_A (continued)

digital and reference inputs

		MIN	NOM	MAX	UNIT
High-level input voltage, V _{IH}	DV _{DD} = 3.3 V	2		DV _{DD}	V
	DV _{DD} = 5 V	2.4		DV _{DD}	
Low-level input voltage, V _{IL}		DV _{SS}		0.8	V
Clock frequency, f _{clk}		0		80	MHz
Pulse duration, clock high, t _w (CLKH)		5			ns
Pulse duration, clock low, t _w (CLKL)		5			ns
Reference input voltage, † V _{ref(I)} (see Note 3)			1.35	1.62	V
FSADJ resistor, R _(FS) (see Note 3)		360	430		Ω

† Voltage reference input applies to the externally applied voltage (overdrive condition). Internally a 2 kΩ resistor isolates the internal reference from the externally applied voltage, if any.

NOTE 3: The combination of V_{ref} and R_{FS} can be chosen at will as long as the maximum full-scale DAC output current I_(FS) does not exceed 120% of its nominal value. Therefore, at fixed R_(FS) = R_(FSnom), V_{ref} should not be higher than the maximum value mentioned and at fixed V_{ref} = V_{ref(nom)}, R_(FS) should not be less than the minimum value mentioned.

electrical characteristics over recommended operating conditions with f_{CLK} = 80 MSPS and use of internal reference voltage V_{ref}, with R_(FS) = R_(FSnom) (unless otherwise noted)

power supply (1 MHz, –1 dBFS digital sine simultaneously applied to all 3 channels)

PARAMETER		TEST CONDITIONS	MIN	TYP	MAX	UNIT
I _{DD}	Operating supply current	AV _{DD} = DV _{DD} = 5 V		134	142	mA
		AV _{DD} = 5 V, DV _{DD} = 3.3		114	121	
P _D	Power dissipation	AV _{DD} = DV _{DD} = 5 V		670	710	mW
		AV _{DD} = 5 V, DV _{DD} = 3.3		525	565	

digital inputs – dc characteristics

PARAMETER		TEST CONDITIONS	MIN	TYP	MAX	UNIT
I _{IH}	High-level input current	AV _{DD} = DV _{DD} = 5 V Digital inputs and CLK at 0 V for I _{IL} ; Digital inputs and CLK at 5 V for I _{IH}			1	μA
I _{IL}	Low-level input current				–1	μA
I _{IL} (CLK)	Low-level input current, CLK				1	μA
I _{IH} (CLK)	High-level input current, CLK		–1			
C _I	Input capacitance	T _A = 25°C		7		pF
t _s	Data and control inputs setup time		3			ns
t _H	Data and control inputs hold time		0			ns
t _d (D)	Digital process delay from first registered color component of pixel‡ (see Figures 3–5)	RGB and YPbPr 4:4:4		7		CLK periods
		YPbPr 4:2:2 2×10 bit		8		
		YPbPr 4:2:2 1×10 bit		9		

‡ This parameter is assured by design and not production tested. The digital process delay is defined as the number of CLK cycles required for the first registered color component of a pixel, starting from the time of registering it on the input bus, to propagate through all processing and appear at the DAC output drivers. The remaining delay through the IC is the analog delay t_{d(A)} of the analog output drivers.

THS8133, THS8133A
TRIPLE 10-BIT, 80 MSPS VIDEO D/A CONVERTER
WITH TRI-LEVEL SYNC GENERATION
 SLVS204B – APRIL 1999 – REVISED OCTOBER 1999

electrical characteristics over recommended operating conditions with $f_{CLK} = 80$ MSPS and use of internal reference voltage V_{ref} , with $R_{(FS)} = R_{(FSnom)}$ (unless otherwise noted) (continued)

analog (DAC) outputs

PARAMETER		TEST CONDITIONS	MIN	TYP	MAX	UNIT	
DAC resolution			10	10		bits	
INL	Integral nonlinearity	Static, best fit		±0.6	±1.2	LSB	
DNL	Differential nonlinearity	Static		-0.25/0.5	±1	LSB	
PSRR	Power supply ripple rejection ratio of DAC output (full scale)	f = 100 kHz (see Note 4)		37		dB	
		f = 1 MHz (see Note 4)		43			
XTALK	Crosstalk between channels	f up to 30 MHz, (see Note 5)			-55	dB	
$V_{O(ref)}$	Voltage reference output		1.30	1.35	1.40	V	
$r_o(VREF)$	V_{REF} output resistance		7K	11K	15K	W	
$G_{(DAC)}$	DAC gain factor		See Table 4				
Imbalance between DACs, (K_{IMBAL})		See Note 6			±5%		
Imbalance between positive and negative sync, ($K_{IMBAL(SYNC)}$)		See Note 6			±2%		
$V_{O(DAC)}$	DAC output compliance voltage (sync+video)	$R_L = 37.5 \Omega$, See Note 7		1	1.2	V	
		$R_L = 75 \Omega$, See Note 7		2	2.4		
$I_{(FS)}$	GBR sync-on-green and YPbPr sync-on-Y/sync-on-all	Internal reference	AGY	24	26.67	28	mA
			ABPb and ARPr	17.3	18.67	19.7	
		External reference	AGY	24.9	26.67	27.2	
			ABPb and ARPr	17.5	18.67	19.3	
	GBR sync-on-all	Internal reference	AGY	24	26.67	28	mA
			ABPb and ARPr	24	26.67	28	
External reference	AGY	24.9	26.67	27.2			
	ABPb and ARPr	24.9	26.67	27.2			
r_o	DAC output resistance	See Note 10	57		92	k Ω	
C_O	DAC output capacitance (pin capacitance)			8		pF	
$t_r(DAC)$	DAC output current risetime	10% to 90% of full scale		2		ns	
$t_f(DAC)$	DAC output current falltime	10% to 90% of full scale		2		ns	
$t_d(A)$	Analog output delay	Measured from $CLK=V_{IH(min)}$ to 50% of full-scale transition, See Note 8			9	ns	
t_S	Analog output settling time	Measured from 50% of full scale transition on output to output settling, within 2%, See Note 9		5	9	ns	
SNR	Signal -to-noise ratio	1 MHz, -1 dBFS digital sine input, measured from 0 MHz to 8.8 MHz		57.5		dB	
SFDR	Spurious-free dynamic range	1MHz, -1 dBFS digital sine input, measured from 0 MHz to 8.8 MHz		64		dB	
BW(1 dB)	Bandwidth	See Note 11		40		MHz	

- NOTES:
- PSRR is measured with a 0.1 μ F capacitor between the COMP and AVDD terminal; with a 0.1 μ F capacitor connected between the V_{REF} terminal and AVSS. The ripple amplitude is within the range 100 mVp-p to 500 mVp-p with the DAC output set to full scale and a double-terminated 75 Ω (=37.5 Ω) load. PSRR is defined as $20 \times \log(\text{ripple voltage at DAC output}/\text{ripple voltage at AVDD input})$. Limits from characterization only.
 - Crosstalk spec applies to each possible pair of the 3 DAC outputs. Limits from characterization only.
 - The imbalance between DACs applies to all possible pairs of the three DACs. K_{IMBAL} is assured over full temperature range. In parts labeled THS8133CPHP, $K_{IMBAL(SYNC)}$ is assured at 25°C. In parts labeled THS8133ACPHP, $K_{IMBAL(SYNC)}$ is assured over the full temperature range.
 - Nominal values at $R_{(FS)} = R_{(FSnom)}$: Maximum values at $R_{(FS)} = R_{(FSnom)} \div 1.2$. Maximum limits from characterization only.
 - This value excludes the digital process delay, $t_d(D)$. Limit from characterization only.
 - Maximum limit from characterization only
 - Limit from characterization only
 - This bandwidth relates to the output amplitude variation in excess of the droop from the \sin/x sampled system. Since the output is a sample-and-hold signal, a $\sin(\pi \times F_{IN} + F_{CLK}) + (\pi \times F_{IN} + F_{CLK})$ roll-off is observed, which accounts e.g. at $F_{IN} = 40$ MHz and $F_{CLK} = 80$ MSPS for -3.92 dB signal drop (*sync droop*). The total DAC output variation (*device droop*) consists of this and an additional amount (*excess droop*) caused by the output impedance of the device, as shown in Table 5.

THS8133, THS8133A
TRIPLE 10-BIT, 80 MSPS VIDEO D/A CONVERTER
WITH TRI-LEVEL SYNC GENERATION

SLVS204B – APRIL 1999 – REVISED OCTOBER 1999

performance plots of AGY output channel at 80 MSPS and use of internal reference

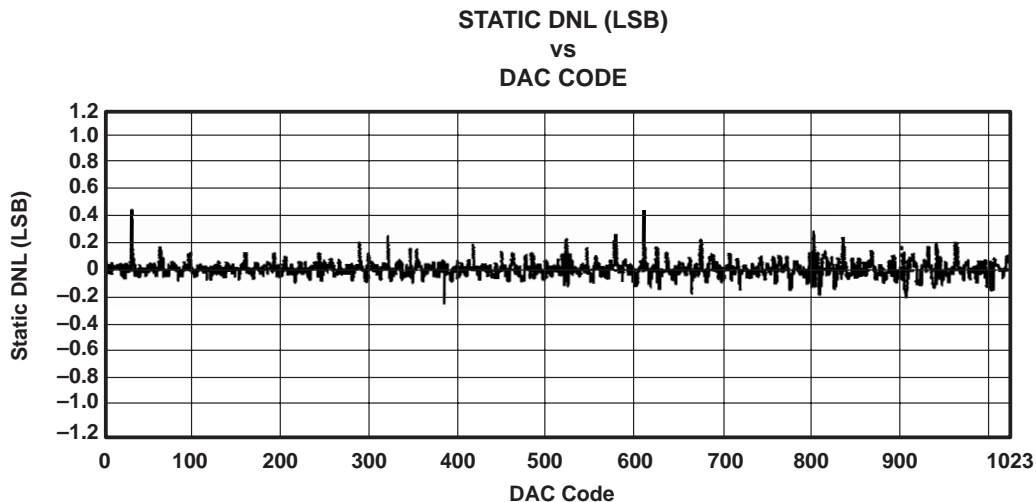

Figure 7. Static DNL

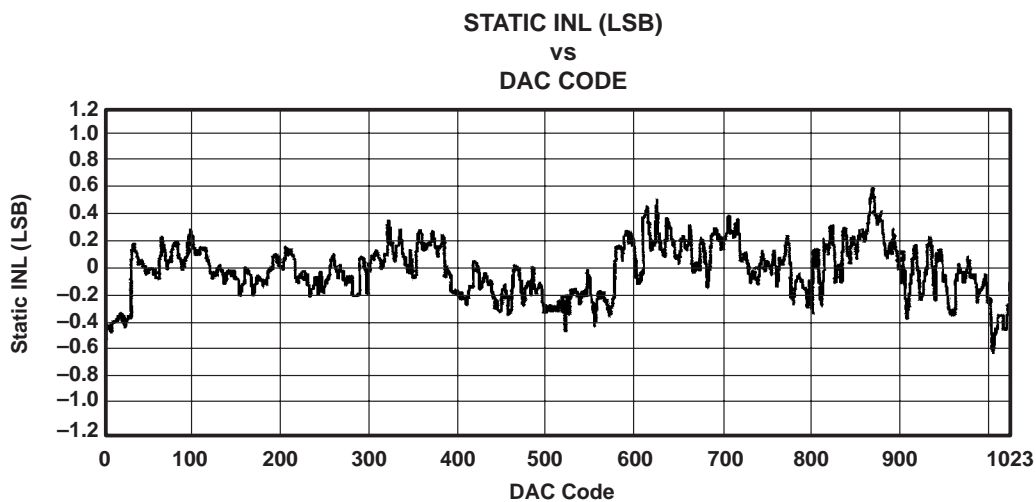

Figure 8. Static INL

performance plots of AGY output channel at 80 MSPS and use of internal reference (continued)

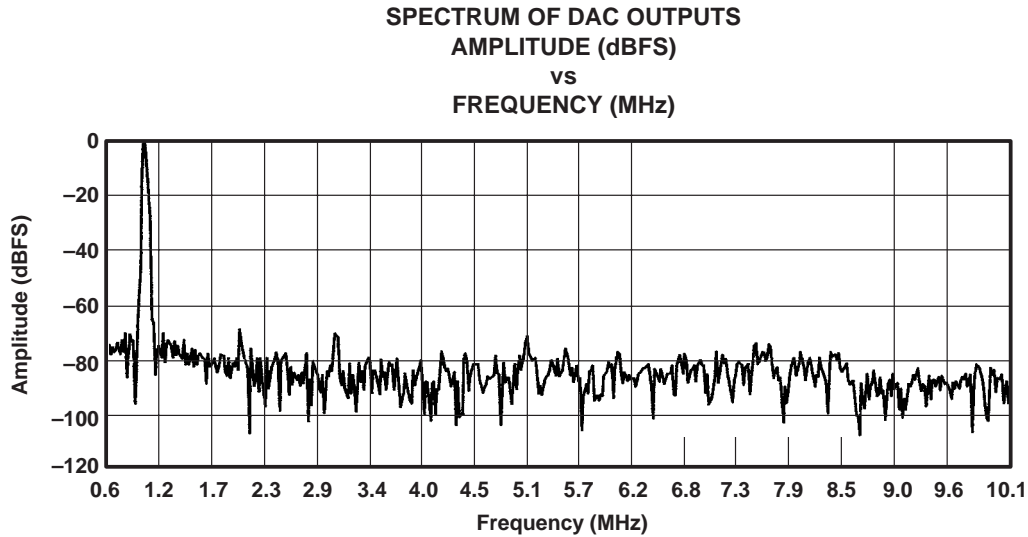

Figure 9. Spectral Plot for 1.02 MHz Digital Sine Input at 80 MSPS

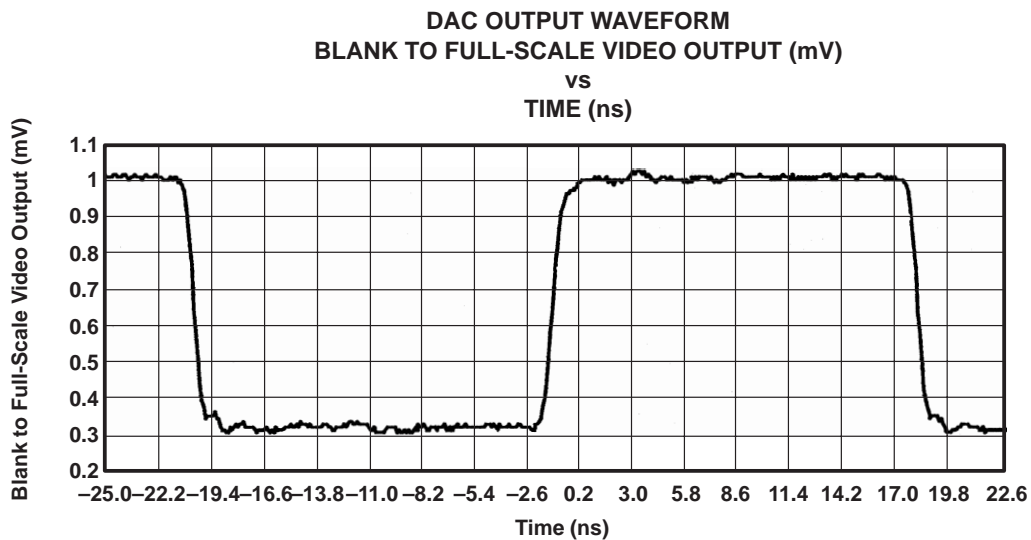

Figure 10. DAC Output Waveform (rise/fall and settling times)

Table 5. DAC Output Amplitude Variation Over Varying F_{in} at $F_{clk} = 80$ MSPS

F_{in} (kHz)	F_{clk} (MSPS)	SYNC DROOP (dB)	EXCESS DROOP (dB)
500	80	0	0
5000	80	-0.056	-0.02
10000	80	-0.22	-0.08
20000	80	-0.91	-0.29
30000	80	-2.11	-0.39
40000	80	-3.92	-0.40

THS8133, THS8133A
TRIPLE 10-BIT, 80 MSPS VIDEO D/A CONVERTER
WITH TRI-LEVEL SYNC GENERATION

SLVS204B – APRIL 1999 – REVISED OCTOBER 1999

APPLICATION INFORMATION

configuring THS8133 for generating SMPTE compliant signals

Table 6 lists the standards that relate to the definition of analog interfaces for component video signals.

Table 6. Relevant Video Standards

STANDARD	TITLE	SCOPE
SMPTE 253M	3-channel RGB Analog Video Interface	Component analog video for studio applications using 525 lines, 59.94 fields, 2:1 interlace and 4:3 or 16:9 aspect ratio.
SMPTE 274M	1920x1080 Scanning and Analog and Parallel Digital Interfaces for Multiple-Picture Rates	Definition of image format of 1920x1080 pixels inside a total raster of 1125 lines, with an aspect ratio of 16:9. Interlaced format used for 1080i display definition of the ATSC HDTV standard.
SMPTE 296M	1280x720 Scanning, Analog and Digital Representation and Analog Interface	Definition of image format of 1280x720 pixels inside a total raster of 750 lines, with an aspect ratio of 16:9. Progressive format used for 720P display definition of the ATSC HDTV standard.

THS8133 can be used to generate output signals compliant to each of these standards. The configuration for each is detailed below. In each of the cases the current output of each DAC can be converted into standard-compliant voltage levels by connecting a double terminated 75Ω load, as shown in the top part of Figure 11.

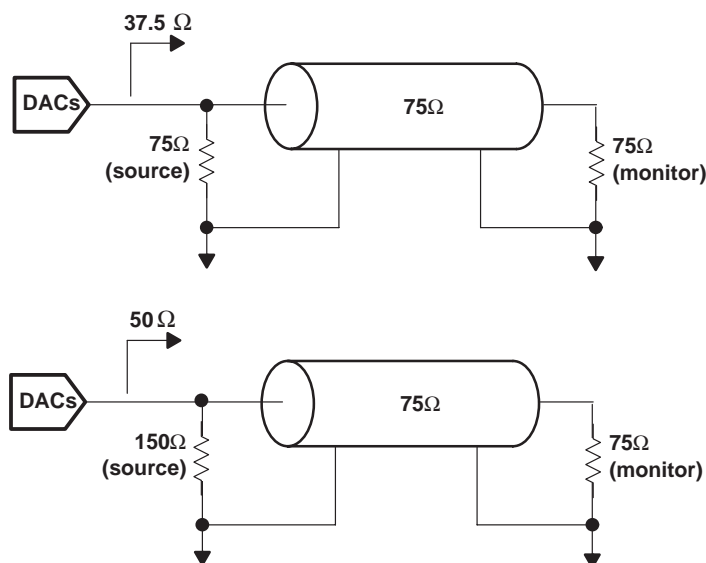

Figure 11. Typical Video Loads

The use of THS8133 for each of these standards is discussed next.

SMPTE 253M

This standard defines a component analog video interface using GBR color signals carried on parallel channels for the interconnection of television equipment. The scanning structure is typically 525 lines, 59.94 fields, 2:1 interlace and 4:3 or 16:9 aspect ratio. The analog signals of this standard are suitable for the generation of, or they can be generated from, digital video signals compliant to SMPTE 125M and SMPTE 267M by A/D or D/A conversion respectively. Furthermore SMPTE 253M signals can be the input to NTSC composite encoders compliant with SMPTE 170M. Table 7 lists the scope of the standards mentioned.

APPLICATION INFORMATION

SMPTE 253M (continued)

Table 7. Video Standards Compatible with SMPTE 253M

STANDARD	TITLE
SMPTE 125M	Component Video Signal 4:2:2 – Bit-Parallel Digital Interface
SMPTE 267M	Bit-Parallel Digital Interface – Component Video Signal 4:2:2 16x9 Aspect Ratio
SMPTE 170M	Composite Analog Video Signal – NTSC for Studio Applications

The SMPTE 253M standard defines a GBR component set with positive going signals and a maximum peak level of 700 mV from blanking level. The green signal has a negative-going sync pulse of amplitude 300 mV from blanking level. The dc offset, as defined by the blanking level of the signal, is $0.0\text{ V} \pm 1.0\text{ V}$. Figure 12 shows the waveform of the green channel, onto which the horizontal sync is inserted.

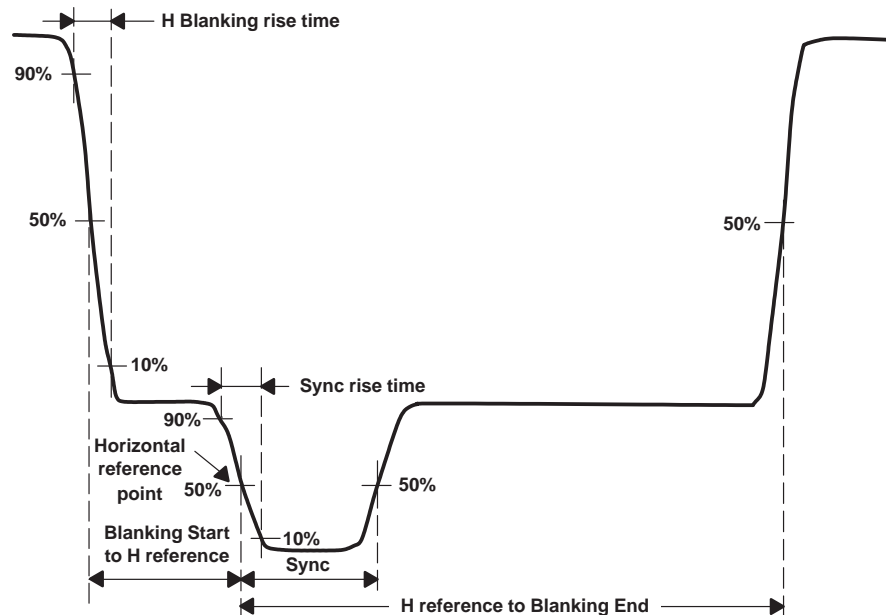

Figure 12. SMPTE 253M Line Waveform (green channel)

For this mode, the INS3_INT control should be kept low to enable sync-on-green only and the device is put in GBR 4:4:4 mode. This corresponds to the GBR with sync-on-green operation mode of Table 1.

Table 8 lists the THS8133 output currents that will produce compliant signals to this standard after proper termination, together with the required input signals.

Table 8. THS8133 Signals for SMPTE 253M Compliant Operation

LEVEL	AGY		ARPr, ABPb		SYNC	SYNC_T	BLANK	DAC INPUT
	(mA)	(V)	(mA)	(V)				
White	26.67	1.000	18.67	0.7000	1	X	1	3FF _h
Video	video+8.00	video+0.3	video	video	1	X	1	data
Black	8.00	0.3000	0	0	1	X	1	000 _h
Blank	8.00	0.3000	0	0	1	X	0	xxx _h
Sync	0	0	0	0	0	0	x	xxx _h

THS8133, THS8133A TRIPLE 10-BIT, 80 MSPS VIDEO D/A CONVERTER WITH TRI-LEVEL SYNC GENERATION

SLVS204B – APRIL 1999 – REVISED OCTOBER 1999

APPLICATION INFORMATION

SMPTE 253M (continued)

$\overline{\text{BLANK}}$ can be tied high in this mode if the data input is kept to 000h during the blanking time, since black and blanking level are at identical levels. Furthermore the SYNC_T terminal remains low, since only a bi-level sync is generated.

SMPTE 274M

This standard defines a raster scanning format of 1920×1080 pixels inside a total raster of 1125 lines and an aspect ratio of 16:9, GBR and YPbPr color encoding formats and both analog and digital interfaces for GBR and YPbPr formats.

With respect to the analog interface, SMPTE 274M defines the position of the start of each line at the positive zero-crossing of a tri-level sync pulse. The sync pulse has a negative-going transition on a fixed number of clock cycles preceding this instant and another negative transition on a fixed number of clock cycles following this instant, as shown in Figure 13. The positive peak of sync is 300 mV; the negative peak of sync –300 mV.

The interface can carry both GBR or YPbPr signals. The tri-level horizontal sync is inserted on all analog outputs and has identical absolute amplitude levels in all cases. For Y, black corresponds to a level of 0 V and peak white is 700 mV. Pb and Pr on the other hand have amplitudes between –350 mV and 350 mV.

The relative amplitudes of the current sources are identical to the case of SMPTE 253M. However, in this case a tri-level sync needs to be generated instead of a bi-level negative sync, and it needs to be present on all three component outputs. THS8133 supports the tri-level sync via an additional internal current source, activated by asserting SYNC_T. The sync insertion on all outputs is under the control of the INS3_INT pin. When asserted (high), the sync is inserted on all three output channels.

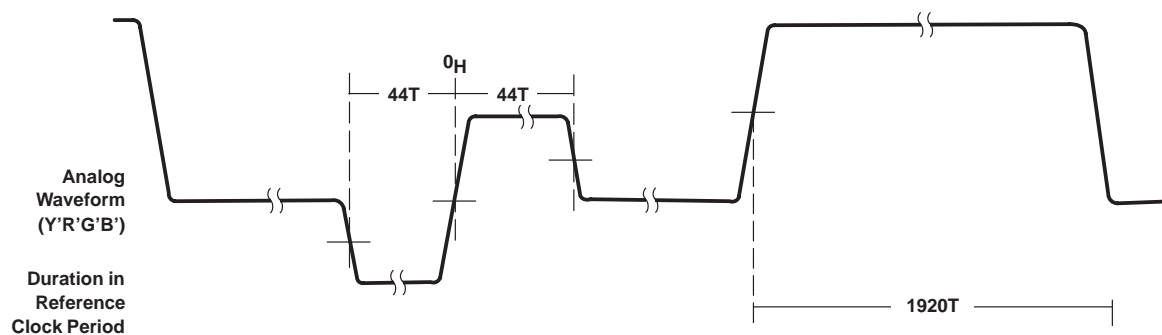

Figure 13. SMPTE 274M Line Waveform†

† This figure is for illustration purposes only. Consult the latest SMPTE 274M standard when designing a compliant system.

Figure 14 shows the relative amplitudes of video and horizontal/vertical sync. The level of vertical sync (broad pulse) is identical to the negative excursion of horizontal sync and therefore can be generated by the same current source on THS8133 by appropriately asserting the sync control inputs.

APPLICATION INFORMATION

SMPTE 274M (continued)

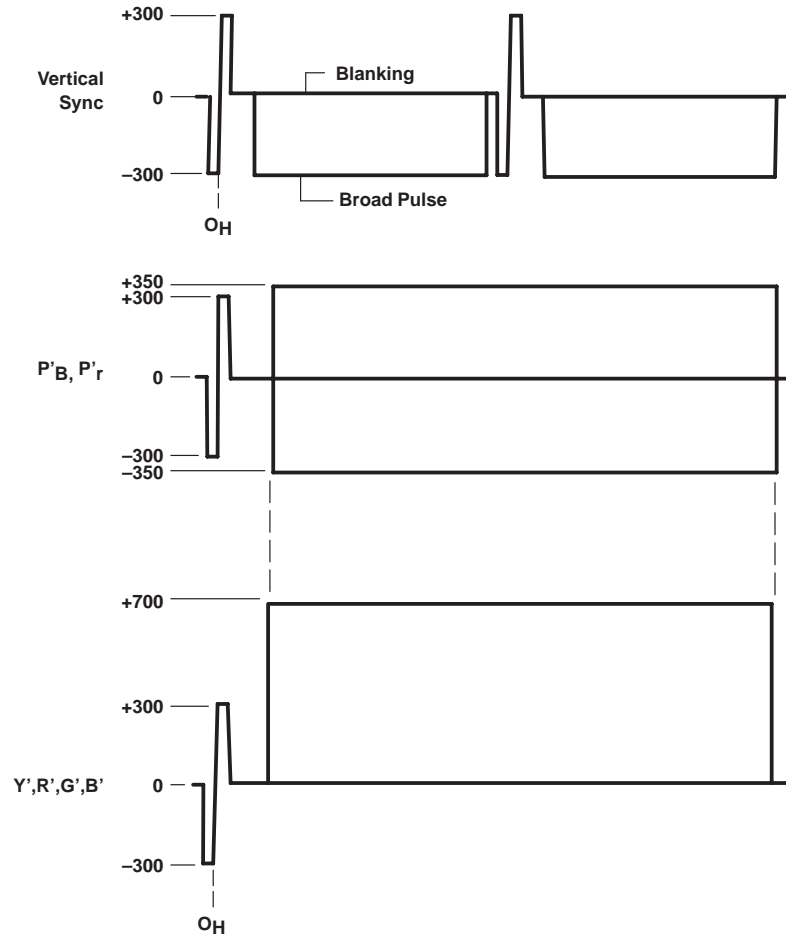

Figure 14. SMPTE 274M Analog Interface Horizontal Timing Details[†]

[†] This figure is for illustration purposes only. Consult the latest SMPTE 274M standard when designing a compliant system.

For GBR operation, Table 9 lists the THS8133 full-scale output currents that produce compliant signals to the standard after proper termination. These amplitudes are valid also in YPbPr mode for the Y channel. For GBR operation, the device needs to be configured with INS3_INT high, corresponding to the GBR with sync-on-all operation mode of Table 1.

THS8133, THS8133A
TRIPLE 10-BIT, 80 MSPS VIDEO D/A CONVERTER
WITH TRI-LEVEL SYNC GENERATION

SLVS204B – APRIL 1999 – REVISED OCTOBER 1999

APPLICATION INFORMATION

SMPTE 274M (continued)

Table 9. THS8133 Signals for SMPTE 274M Compliant Operation on GBR and Y Channels

LEVEL	GBRY		SYNC	SYNC_T	BLANK	DAC INPUT
	(mA)	(V)				
White	26.67	1.000	1	X	1	3FF _h
Video	video+8.00	video+0.3	1	X	1	data
Sync Pos	16.00	0.600	0	1	X	xxx _h
Black	8.00	0.3000	1	X	1	000 _h
Blank	8.00	0.3000	1	X	0	xxx _h
Sync Neg	0	0	0	0	X	xxx _h

In the YPbPr mode of this standard, the sync is centered around the center span of the video amplitude levels, as shown in Figure 14. So the current for Pb and Pr is down-shifted with respect to Y to accommodate the minimum data level at 0 mA. Thus, an input code of 00h corresponds now to an output drive of 0 mA while the negative sync level is at 1.33 mA, corresponding to 50 mV. The Pb and Pr data input format is offset binary.

Table 10 lists the THS8133 full-scale output currents for Pb and Pr channels in the YPbPr operation mode of the device. The operation mode corresponds to YPbPr with sync-on-all of Table 1.

Table 10. THS8133 Signals for SMPTE 274M Compliant Operation on Pb and Pr Channels

LEVEL	Pb, Pr		SYNC	SYNC_T	BLANK	DAC INPUT
	(mA)	(V)				
Max	18.67	0.7000	1	X	1	3FF _h
Video	video	video	1	X	1	data
Sync Pos	17.33	0.650	0	1	X	xxx _h
Blank	9.33	0.350	1	X	0	xxx _h
Sync Neg	1.33	0.050	0	0	x	xxx _h
Min	0	0	1	X	1	000 _h

SMPTE 296M

This standard defines a raster scanning format of 1280x720 and an aspect ratio of 16:9, the analog and digital representation, and the definition of an analog interface. Both GBR and YPbPr component color encoding can be used.

With respect to the sync and video level definition, this standard is analogous to SMPTE 274M with the use of a tri-level sync pulse. Therefore, for the generation of output signals compliant to this standard, refer to the configuration of THS8133 for SMPTE 274M.

APPLICATION INFORMATION

comparison to EIA RS-343/RS-170 levels

Traditionally, video amplitude levels are specified according to the EIA RS-343 or RS-170 standards. RS-343 uses a bi-level negative going sync. Also, there is a difference between the reference blanking and black video level. Figure 15 shows the relative amplitudes and the current drives that would be needed to generate compliant relative amplitudes with a double-terminated 75-Ω load, as is specified for RS-343. RS-170 compliant levels can be reached using the same current sources but a different 150-Ω source termination resistor, which brings the load to $150 \parallel 75 \Omega = 50 \Omega$. In this case a blank-to-white level of approximately 1 V is reached ($0.714 \text{ V} \times 50 \div 37.5$) as required by RS-170.

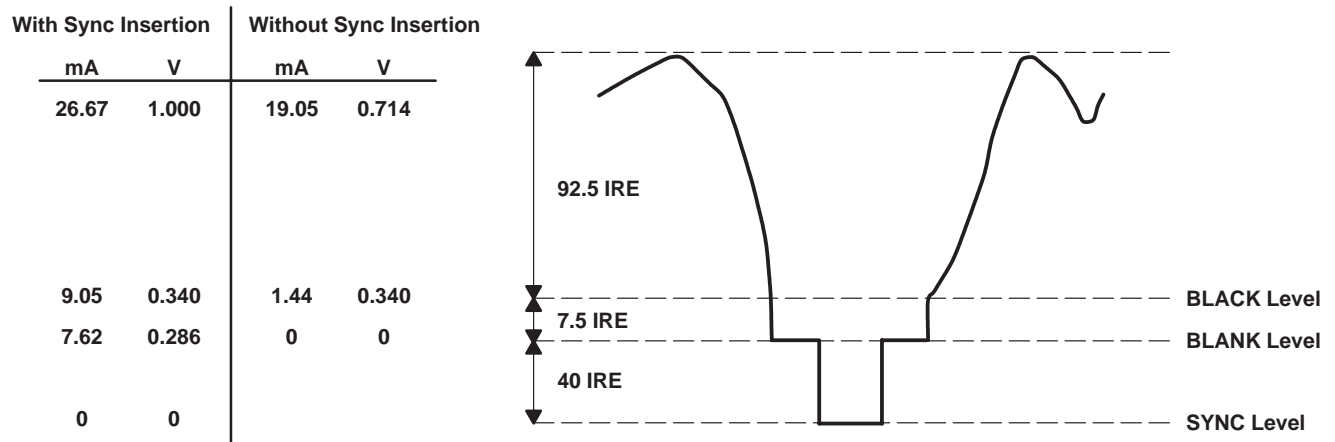

Figure 15. RS-343 Video Definition

The video signal contains 140 IRE, equal to 1 Vpp. This is split into 40 IRE for the composite sync, 7.5 IRE for blanking-to-black and 92.5 IRE for the active video portion.

designing with PowerPAD™

The THS8133 is housed in a high-performance, thermally enhanced, 48-pin PowerPAD package (TI package designator: 48PHP). Use of the PowerPAD package does not require any special considerations except to note that the PowerPAD which is an exposed die pad on the bottom of the device, is a metallic thermal and electrical conductor. Therefore, if not implementing the PowerPAD PCB features, solder masks (or other assembly techniques) may be required to prevent any inadvertent shorting by the exposed PowerPAD of connection etches or vias under the package. The recommended option, however, is not to run any etches or signal vias under the device, but to have only a grounded thermal land as explained below. Although the actual size of the exposed die pad may vary, the minimum size required for the keepout area for the 48-pin PHP PowerPAD package is 7 mm × 7 mm.

It is recommended that there be a thermal land, which is an area of solder-tinned-copper, underneath the PowerPAD package. The thermal land will vary in size, depending on the PowerPAD package being used, the PCB construction, and the amount of heat that needs to be removed. In addition, the thermal land may or may not contain numerous thermal vias, depending on PCB construction.

More information on this package and other requirements for using thermal lands and thermal vias are detailed in the TI application note *PowerPAD™ Thermally Enhanced Package Application Report*, TI literature number SLMA002, available via the TI Web pages beginning at URL: <http://www.ti.com>.

THS8133, THS8133A
TRIPLE 10-BIT, 80 MSPS VIDEO D/A CONVERTER
WITH TRI-LEVEL SYNC GENERATION

SLVS204B – APRIL 1999 – REVISED OCTOBER 1999

designing with PowerPAD™ (continued)

For the THS8133 this thermal land should be grounded to the low impedance ground plane of the device. This improves not only thermal performance but also the electrical grounding of the device. It is also recommended that the device ground terminal landing pads be connected directly to the grounded thermal land. The land size should be as large as possible without shorting device signal terminals. The thermal land may be soldered to the exposed PowerPAD using standard reflow soldering techniques.

While the thermal land may be electrically floated and configured to remove heat to an external heat sink, it is recommended that the thermal land be connected to the low impedance ground plane for the device.

Table 11 lists a comparison for thermal resistances between the PowerPAD package (48PHP) used for this device and a regular 48-pin TQFP package (48PFB).

Table 11. Junction-Ambient and Junction-Case Thermal Resistances

48PHP PowerPAD vs 48PFB REGULAR TQFP	AIRFLOW IN lfm			
	0	150	250	500
θ_{JA} (°C/W) 48PHP	29.1	23.1	21.6	19.9
θ_{JC} (°C/W) 48PHP	1.14			
θ_{JA} (°C/W) 48PFB	97.5	78.3	71.6	63.5
θ_{JC} (°C/W) 48PFB	19.6			

THS8133, THS8133A
TRIPLE 10-BIT, 80 MSPS VIDEO D/A CONVERTER
WITH TRI-LEVEL SYNC GENERATION
 SLVS204B – APRIL 1999 – REVISED OCTOBER 1999

MECHANICAL DATA

PHP (S-PQFP-G48)

PowerPAD™ PLASTIC QUAD FLATPACK

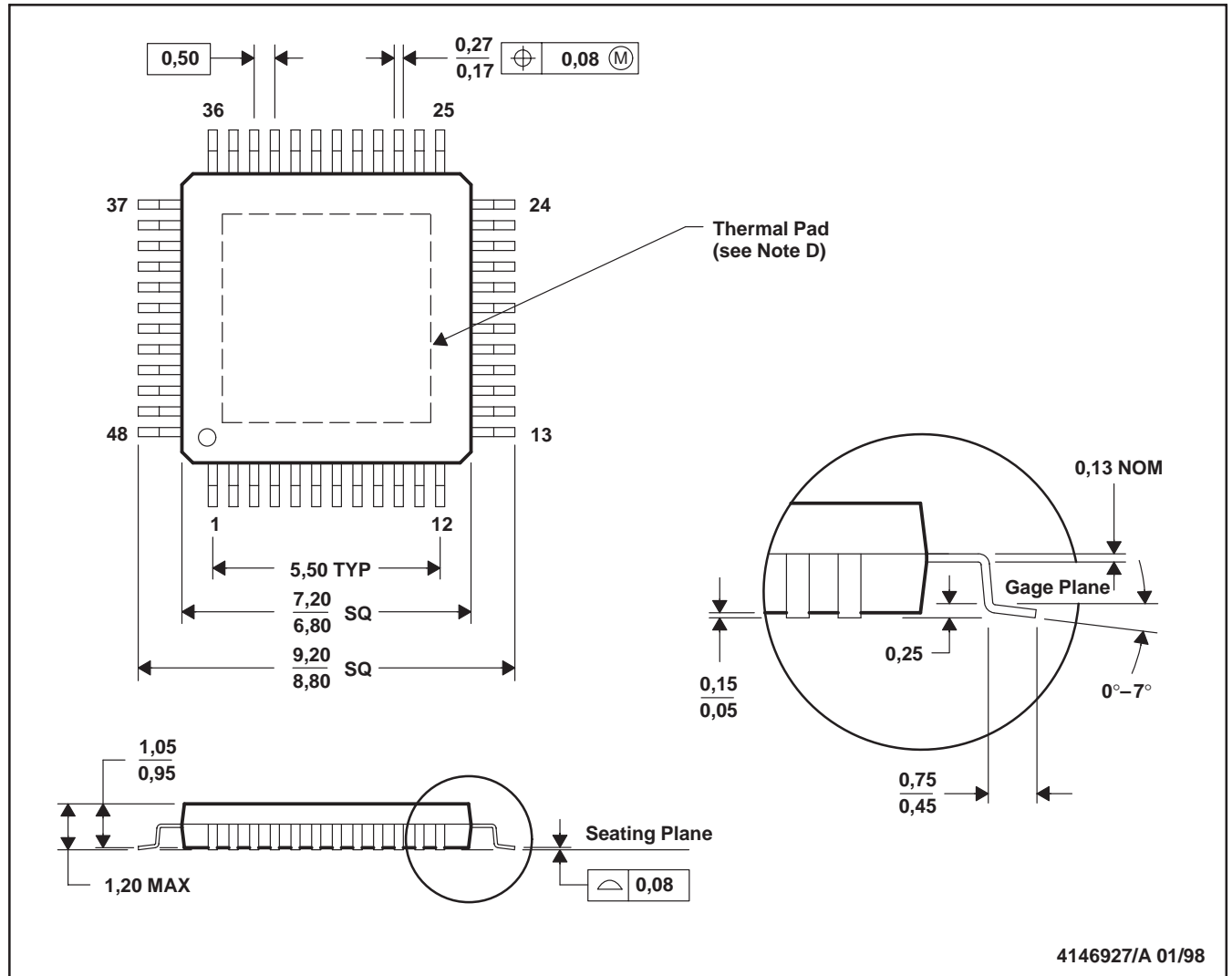

- NOTES:
- A. All linear dimensions are in millimeters.
 - B. This drawing is subject to change without notice.
 - C. Body dimensions do not include mold flash or protrusions.
 - D. The package thermal performance may be enhanced by bonding the thermal pad to an external thermal plane. This pad is electrically and thermally connected to the backside of the die and possibly selected leads.
 - E. Falls within JEDEC MO-153

IMPORTANT NOTICE

Texas Instruments and its subsidiaries (TI) reserve the right to make changes to their products or to discontinue any product or service without notice, and advise customers to obtain the latest version of relevant information to verify, before placing orders, that information being relied on is current and complete. All products are sold subject to the terms and conditions of sale supplied at the time of order acknowledgement, including those pertaining to warranty, patent infringement, and limitation of liability.

TI warrants performance of its semiconductor products to the specifications applicable at the time of sale in accordance with TI's standard warranty. Testing and other quality control techniques are utilized to the extent TI deems necessary to support this warranty. Specific testing of all parameters of each device is not necessarily performed, except those mandated by government requirements.

CERTAIN APPLICATIONS USING SEMICONDUCTOR PRODUCTS MAY INVOLVE POTENTIAL RISKS OF DEATH, PERSONAL INJURY, OR SEVERE PROPERTY OR ENVIRONMENTAL DAMAGE ("CRITICAL APPLICATIONS"). TI SEMICONDUCTOR PRODUCTS ARE NOT DESIGNED, AUTHORIZED, OR WARRANTED TO BE SUITABLE FOR USE IN LIFE-SUPPORT DEVICES OR SYSTEMS OR OTHER CRITICAL APPLICATIONS. INCLUSION OF TI PRODUCTS IN SUCH APPLICATIONS IS UNDERSTOOD TO BE FULLY AT THE CUSTOMER'S RISK.

In order to minimize risks associated with the customer's applications, adequate design and operating safeguards must be provided by the customer to minimize inherent or procedural hazards.

TI assumes no liability for applications assistance or customer product design. TI does not warrant or represent that any license, either express or implied, is granted under any patent right, copyright, mask work right, or other intellectual property right of TI covering or relating to any combination, machine, or process in which such semiconductor products or services might be or are used. TI's publication of information regarding any third party's products or services does not constitute TI's approval, warranty or endorsement thereof.