

# 2SC3020

## NPN EPITAXIAL PLANAR TYPE

### DESCRIPTION

2SC3020 is a silicon NPN epitaxial planar type transistor designed for UHF power amplifier applications.

### FEATURES

- High gain:  $G_{pe} \geq 10\text{dB}$ , @  $f = 520\text{MHz}$ ,  $V_{CC} = 12.5\text{V}$ ,  $P_{in} = 0.3\text{W}$ .
- High ruggedness: Ability to withstand more than 20:1 load VSWR (all phase) when operated at  $V_{CC} = 15.2\text{V}$ ,  $f = 520\text{MHz}$ ,  $P_O = 3\text{W}$ .
- Emitter ballasted construction.
- Low thermal resistance:  $R_{th} = 15 \text{ }^\circ\text{C/W}$  ( $T_C = 25^\circ\text{C}$ )
- Convenient flange type ceramic package.

### APPLICATION

For drive stage and output stage of 400MHz band mobile radio.

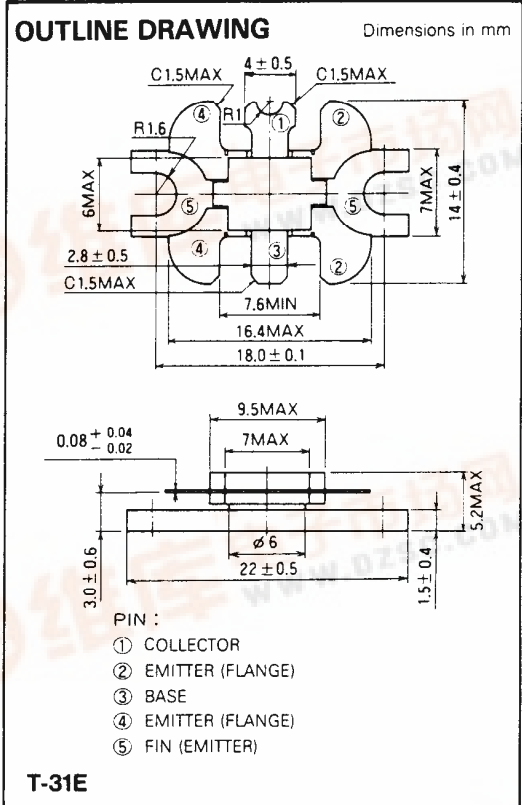

### ABSOLUTE MAXIMUM RATINGS ( $T_C = 25^\circ\text{C}$ )

Symbol	Parameter	Conditions	Ratings	Unit
$V_{CBO}$	Collector to base voltage		35	V
$V_{EBO}$	Emitter to base voltage		4.0	V
$V_{CEO}$	Collector to emitter voltage	$R_{BE} = \infty$	17	V
$I_C$	Collector current		1	A
$P_C$	Collector dissipation	$T_C = 25^\circ\text{C}$	10	W
$T_j$	Junction temperature		175	$^\circ\text{C}$
$T_{stg}$	Storage temperature		-55 to 175	$^\circ\text{C}$

Note. Above parameters are guaranteed independently.

### ELECTRICAL CHARACTERISTICS ( $T_C = 25^\circ\text{C}$ )

Symbol	Parameter	Test conditions	Limits			Unit
			Min	Typ	Max	
$V_{(BR)EBO}$	Emitter to base breakdown voltage	$I_E = 1\text{mA}$ , $I_C = 0$	4.0			V
$V_{(BR)CBO}$	Collector to base breakdown voltage	$I_C = 10\text{mA}$ , $I_E = 0$	35			V
$V_{(BR)CEO}$	Collector to emitter breakdown voltage	$I_C = 10\text{mA}$ , $R_{BE} = \infty$	17			V
$I_{CBO}$	Collector cut off current	$V_{CB} = 15\text{V}$ , $I_E = 0$			300	$\mu\text{A}$
$I_{EBO}$	Emitter cut off current	$V_{EB} = 3.0\text{V}$ , $I_C = 0$			300	$\mu\text{A}$
$h_{FE}$	DC forward current gain *	$V_{CE} = 10\text{V}$ , $I_C = 0.1\text{A}$	20	50	180	--
$P_O$	Power Output	$V_{CC} = 12.5\text{V}$ , $P_{in} = 0.3\text{W}$ , $f = 520\text{MHz}$	3.0	3.3		W
$\eta_C$	Collector efficiency		50	55		%

Note: \* Pulse test,  $P_W = 150\mu\text{s}$ , duty = 5%.

Above parameters, ratings, limits and conditions are subject to change.



MITSUBISHI RF POWER TRANSISTOR  
**2SC3020**

**NPN EPITAXIAL PLANAR TYPE**

**TEST CIRCUIT (f = 520MHz)**

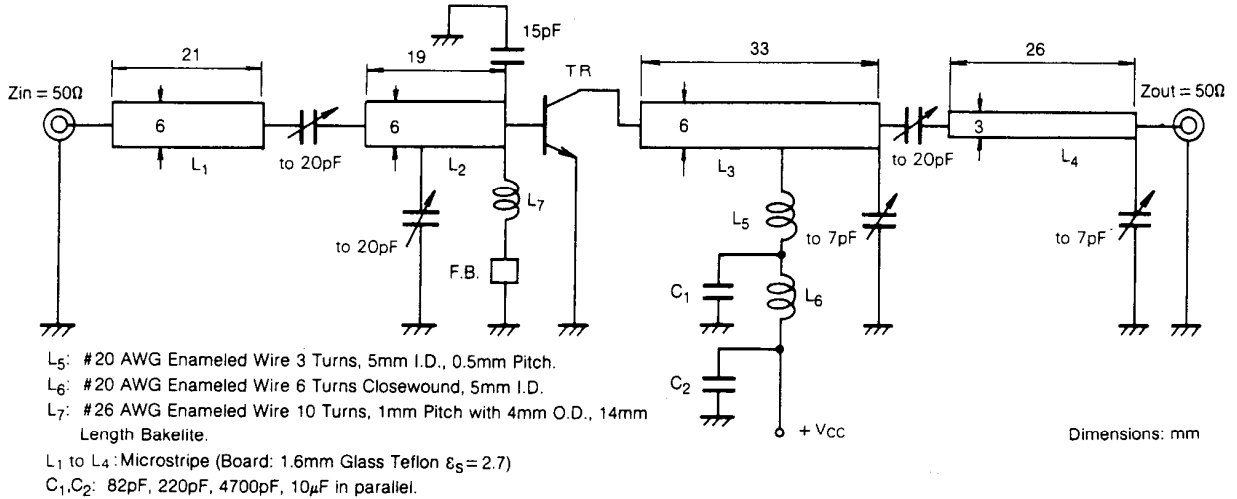

**TYPICAL PERFORMANCE DATA**

**COLLECTOR DISSIPATION VS. CASE TEMPERATURE CHARACTERISTICS**

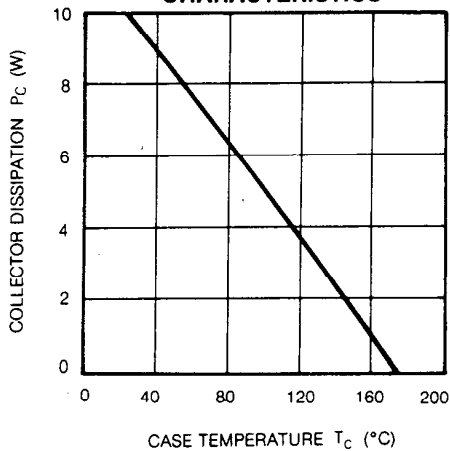

**COLLECTOR OUTPUT CAPACITANCE VS. COLLECTOR TO BASE VOLTAGE**

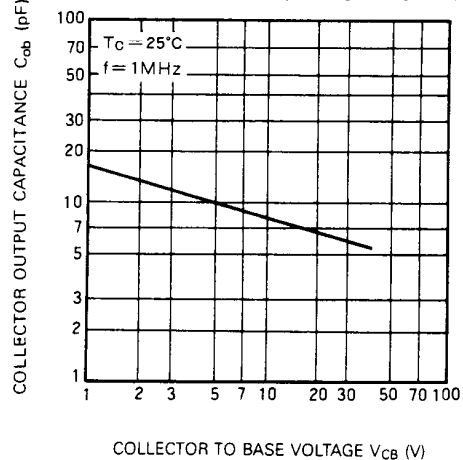

**DC CURRENT GAIN VS. COLLECTOR CURRENT**

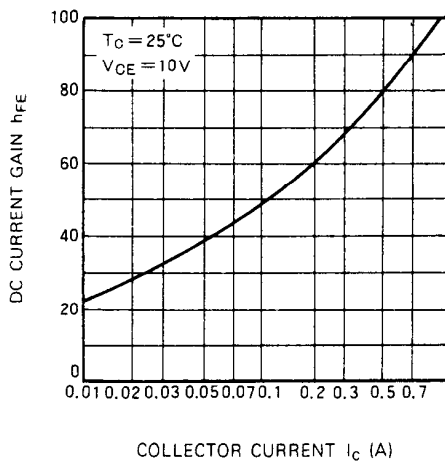

**OUTPUT POWER, COLLECTOR EFFICIENCY VS. INPUT POWER CHARACTERISTICS**

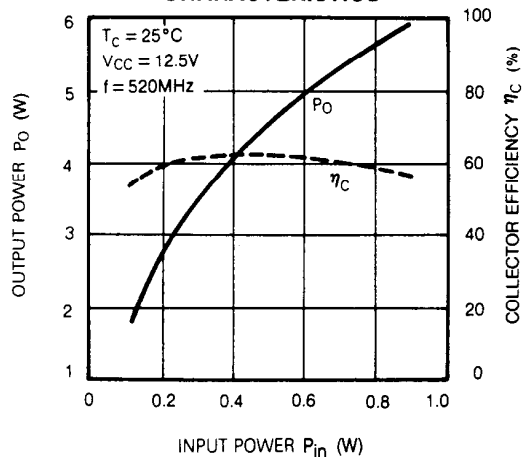

**OUTPUT POWER VS. COLLECTOR SUPPLY VOLTAGE CHARACTERISTICS**

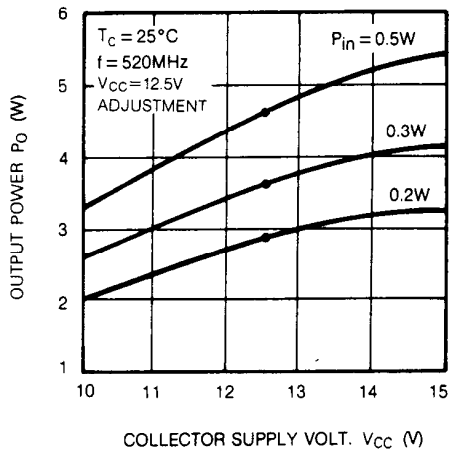

**SERIES INPUT AND OUTPUT IMPEDANCE VS. FREQUENCY CHARACTERISTICS**

