



Monolithic 1.5A, 1.25MHz Step-Down Switching Regulator

November 2000

FEATURES

- 1.5A Switch in a Small MSOP-8 Package
- Constant 1.25MHz Switching Frequency
- Wide Operating Voltage Range: 3V to 25V
- High Efficiency 0.22Ω Switch
- 1.2V Feedback Reference Voltage
- Uses Low Profile Surface Mount Components
- Low Shutdown Current: 6μA
- Synchronizable to 2MHz
- Current Mode Loop Control
- Constant Maximum Switch Current Rating at All Duty Cycles*

APPLICATIONS

- DSL Modems
- Portable Computers
- Wall Adapters
- Battery-Powered Systems
- Distributed Power

DESCRIPTION

The LT[®]1767 is a 1.25MHz monolithic buck mode switching regulator. A high efficiency 1.5A, 0.22Ω switch is included on the die together with all the control circuitry required to complete a high frequency, current mode switching regulator. Current mode control provides fast transient response and excellent loop stability.

New design techniques achieve high efficiency at high switching frequencies over a wide operating range. A low dropout internal regulator maintains consistent performance over a wide range of inputs from 24V systems to Li-Ion batteries. An operating supply current of 1mA improves efficiency, especially at lower output currents. Shutdown reduces quiescent current to 6μA. Maximum switch current remains constant at all duty cycles. Slope compensation no longer affects current limit. Synchronization allows an external logic level signal to increase the internal oscillator from 1.4MHz to 2MHz.

The LT1767 is available in an 8-pin MSOP fused leadframe package. Full cycle-by-cycle short-circuit protection and thermal shutdown are provided. High frequency operation allows the reduction of input and output filtering components and permits the use of chip inductors.

LT, LTC and LT are registered trademarks of Linear Technology Corporation.

*Patent Pending

TYPICAL APPLICATION

5V to 3.3V Step-Down Converter

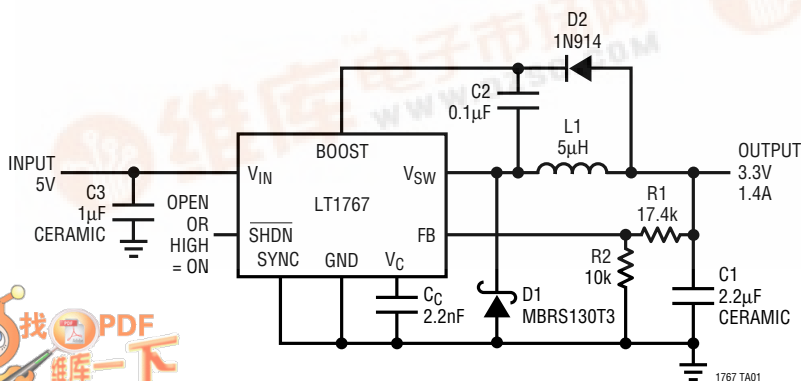

Efficiency vs Load Current

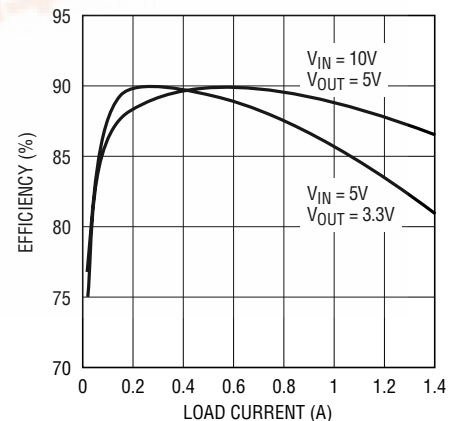

LT1767

ABSOLUTE MAXIMUM RATINGS

(Note 1)

Input Voltage	25V
BOOST Pin Above SW	20V
Max BOOST Pin Voltage	35V
SHDN Pin	25V
FB Pin Voltage	6V
FB Pin Current	1mA
SYNC Pin Current	1mA
Operating Junction Temperature Range (Note 2)	
LT1767E	-40°C to 125°C
Storage Temperature Range	-65°C to 150°C
Lead Temperature (Soldering, 10 sec).....	300°C

PACKAGE/ORDER INFORMATION

<p>TOP VIEW</p> <p>BOOST 1 □ 8 SYNC □ VIN 2 □ 7 VC □ SW 3 □ 6 FB □ GND 4 □ 5 SHDN □</p> <p>MS8 PACKAGE 8-LEAD PLASTIC MSOP</p> <p>$T_{JMAX} = 125^{\circ}\text{C}$, $\theta_{JA} = 110^{\circ}\text{C/W}$</p> <p>GROUND PIN CONNECTED TO LARGE COPPER AREA</p>	ORDER PART NUMBER
	LT1767EMS8
	MS8 PART MARKING
	LTLS

Consult factory for Industrial and Military grade parts.

ELECTRICAL CHARACTERISTICS

The ● denotes the specifications which apply over the full operating temperature range, otherwise specifications are at $T_A = 25^{\circ}\text{C}$. $V_{IN} = 15\text{V}$, $V_C = 0.8\text{V}$, Boost = $V_{IN} + 5\text{V}$, SHDN, SYNC and switch open unless otherwise noted.

PARAMETER	CONDITION	MIN	TYP	MAX	UNITS	
Maximum Switch Current Limit	$T_A = 0^{\circ}\text{C}$ to 125°C	1.5	2	3	A	
	$T_A = < 0^{\circ}\text{C}$	1.3		3	A	
Oscillator Frequency	$3.3\text{V} < V_{IN} < 25\text{V}$		1.1	1.25	1.4	MHz
		●	1.1		1.5	MHz
Switch On Voltage Drop	$I_{SW} = -1.5\text{A}$, $0^{\circ}\text{C} \leq T_A \leq 125^{\circ}\text{C}$ $I_{SW} = -1.3\text{A}$, $T_A < 0^{\circ}\text{C}$			330	380	mV
		●			500	mV
V_{IN} Undervoltage Lockout	(Note 3)	●	2.47	2.6	2.73	V
V_{IN} Supply Current		●		1	1.3	mA
Shutdown Supply Current	$V_{SHDN} = 0\text{V}$, $V_{IN} = 25\text{V}$, $V_{SW} = 0\text{V}$			6	20	μA
		●			45	μA
Feedback Voltage	$3\text{V} < V_{IN} < 25\text{V}$, $0.4\text{V} < V_C < 1\text{V}$		1.18	1.2	1.22	V
		●	1.17		1.23	V
FB Input Current		●		-0.25	-0.5	μA
FB to V_C Voltage Gain	$0.4\text{V} < V_C < 1\text{V}$		150	350		
FB to V_C Transconductance	$\Delta I_{VC} = \pm 10\mu\text{A}$	●	500	850	1300	μMho
V_C Pin Source Current	$V_{FB} = V_{NOM} - 17\%$	●	80	120	160	μA
V_C Pin Sink Current	$V_{FB} = V_{NOM} + 17\%$	●	70	110	180	μA
V_C Pin to Switch Current Transconductance				2.5		A/V
V_C Pin Minimum Switching Threshold	Duty Cycle = 0%			0.35		V
V_C Pin 1.5A I_{SW} Threshold				0.9		V

ELECTRICAL CHARACTERISTICS

The ● denotes the specifications which apply over the full operating temperature range, otherwise specifications are at $T_A = 25^\circ\text{C}$. $V_{IN} = 15\text{V}$, $V_C = 0.8\text{V}$, Boost = $V_{IN} + 5\text{V}$, SHDN, SYNC and switch open unless otherwise noted.

PARAMETER	CONDITION		MIN	TYP	MAX	UNITS
Maximum Switch Duty Cycle	$V_C = 1.2\text{V}$, $I_{SW} = 400\text{mA}$	●	85	90		%
			80			%
Minimum Boost Voltage Above Switch	$I_{SW} = 1.5\text{A}$	●		1.8	2.7	V
Boost Current	$I_{SW} = 0.5\text{A}$ (Note 4)	●		10	15	mA
	$I_{SW} = 1.5\text{A}$ (Note 4)	●		30	45	mA
SHDN Threshold Voltage		●	1.27	1.33	1.40	V
SHDN Threshold Current Hysteresis		●	4	7	10	μA
SHDN Input Current (Shutting Down)	SHDN = 30mV Above Threshold	●	-7	-10	-13	μA
SYNC Threshold Voltage				1.5	2.2	V
SYNC Input Frequency			1.4		2	MHz
SYNC Pin Resistance	$I_{SYNC} = 1\text{mA}$			20		k Ω

Note 1: Absolute Maximum Ratings are those values beyond which the life of a device may be impaired.

Note 2: The LT1767E is guaranteed to meet performance specifications from 0°C to 125°C . Specifications over the -40°C to 125°C operating junction temperature range are assured by design, characterization and correlation with statistical process controls.

Note 3: Minimum input voltage is defined as the voltage where the internal regulator enters lockout. Actual minimum input voltage to maintain a regulated output will depend on output voltage and load current. See Applications Information.

Note 4: Current flows into the BOOST pin only during the on period of the switch cycle.

TYPICAL PERFORMANCE CHARACTERISTICS

FB vs Temperature

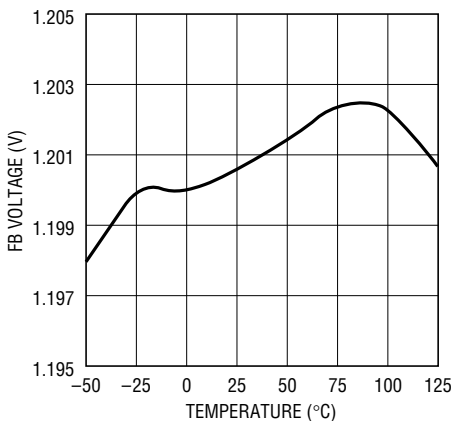

1767 G01

Switch On Voltage Drop

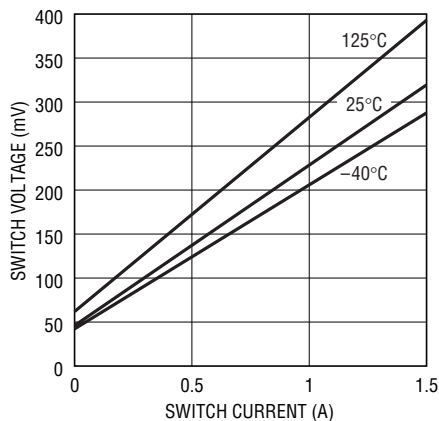

1767 G02

Oscillator Frequency

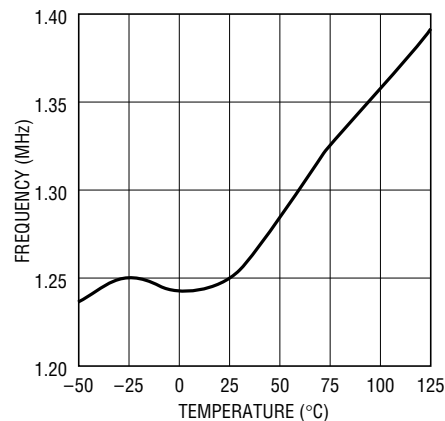

1767 G06

TYPICAL PERFORMANCE CHARACTERISTICS

SHDN Threshold vs Temperature

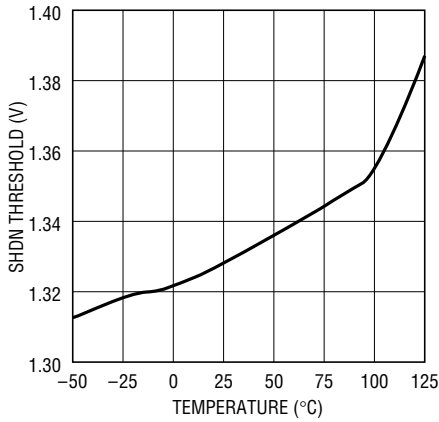

1767 G04

SHDN Supply Current vs V_{IN}

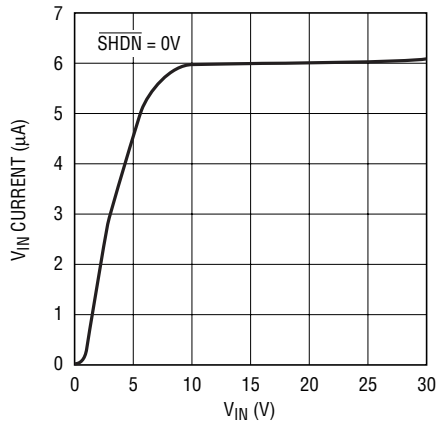

1767 G05

SHDN I_p Current vs Temperature

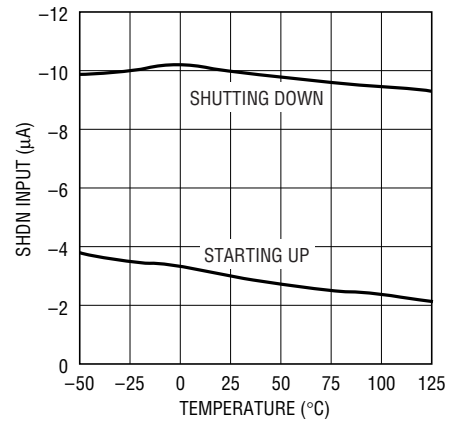

1767 G03

Minimum Input Voltage for 2.5V Out

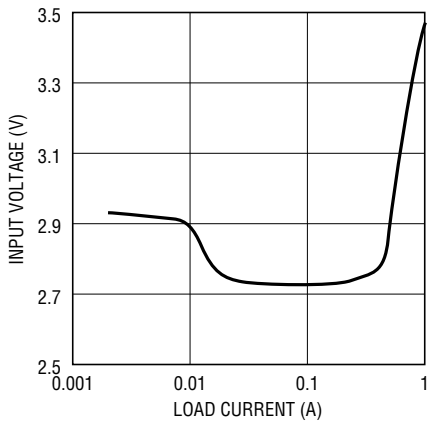

1767 G07

SHDN Supply Current

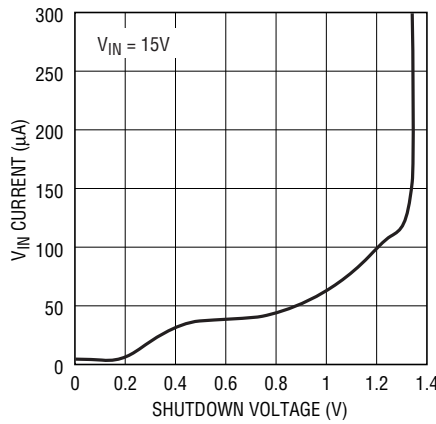

1767 G08

Input Supply Current

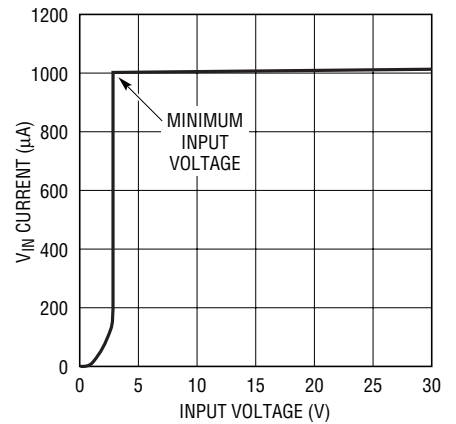

1767 G09

Current Limit Foldback

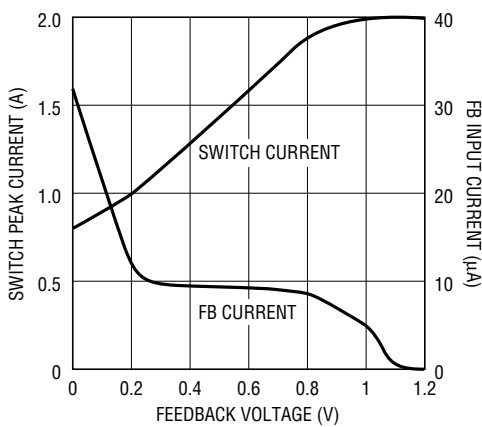

1767 G10

Maximum Load Current, $V_{OUT} = 5V$

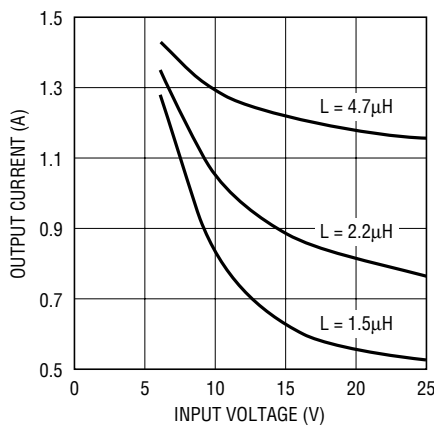

1767 G11

Maximum Load Current, $V_{OUT} = 2.5V$

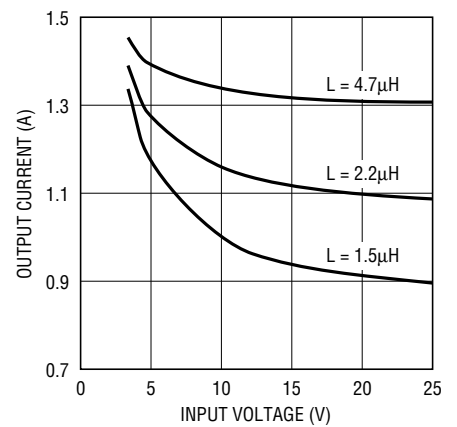

1767 G12

PIN FUNCTIONS

FB: The feedback pin is used to set output voltage using an external voltage divider that generates 1.2V at the pin with the desired output voltage. If required, the current limit can be reduced during start up or short-circuit when the FB pin is below 0.5V (see the Current Limit Foldback graph in the Typical Performance Characteristics section). An impedance of less than 5k Ω at the FB pin is needed for this feature to operate.

BOOST: The BOOST pin is used to provide a drive voltage, higher than the input voltage, to the internal bipolar NPN power switch. Without this added voltage, the typical switch voltage loss would be about 1.5V. The additional boost voltage allows the switch to saturate and voltage loss approximates that of a 0.22 Ω FET structure.

V_{IN}: This is the collector of the on-chip power NPN switch. This pin powers the internal circuitry and internal regulator. At NPN switch on and off, high di/dt edges occur on this pin. Keep the external bypass capacitor and catch diode close to this pin. All trace inductance on this path will create a voltage spike at switch off, adding to the V_{CE} voltage across the internal NPN.

GND: The GND pin acts as the reference for the regulated output, so load regulation will suffer if the “ground” end of the load is not at the same voltage as the GND pin of the IC. This condition will occur when load current or other currents flow through metal paths between the GND pin and the load ground point. Keep the ground path short between the GND pin and the load and use a ground plane when possible. Keep the path between the input bypass and the GND pin short. The GND pin of the package is directly attached to the internal tab. This pin should be attached to a large copper area to improve thermal resistance.

V_{SW}: The switch pin is the emitter of the on-chip power NPN switch. This pin is driven up to the input pin voltage during switch on time. Inductor current drives the switch pin negative during switch off time. Negative voltage must be clamped with an external catch diode with a V_{BR} < 0.8V.

SYNC: The sync pin is used to synchronize the internal oscillator to an external signal. It is directly logic compatible and can be driven with any signal between 20% and 80% duty cycle. The synchronizing range is equal to *initial* operating frequency, up to 2MHz. See Synchronization section in Applications Information for details. When not in use, this pin should be grounded.

SHDN: The shutdown pin is used to turn off the regulator and to reduce input drain current to a few microamperes. The 1.33V threshold can function as an accurate under-voltage lockout (UVLO), preventing the regulator from operating until the input voltage has reached a predetermined level. Float or pull high to put the regulator in the operating mode.

V_C: The V_C pin is the output of the error amplifier and the input of the peak switch current comparator. It is normally used for frequency compensation, but can do double duty as a current clamp or control loop override. This pin sits at about 0.4V for very light loads and 0.9V at maximum load. It can be driven to ground to shut off the output.

BLOCK DIAGRAM

The LT1767 is a constant frequency, current mode buck converter. This means that there is an internal clock and two feedback loops that control the duty cycle of the power switch. In addition to the normal error amplifier, there is a current sense amplifier that monitors switch current on a cycle-by-cycle basis. A switch cycle starts with an oscillator pulse which sets the R_S flip-flop to turn the switch on. When switch current reaches a level set by the inverting input of the comparator, the flip-flop is reset and the switch turns off. Output voltage control is obtained by using the output of the error amplifier to set the switch current trip point. This technique means that the error amplifier commands current to be delivered to the output rather than voltage. A voltage fed system will have low phase shift up to the resonant frequency of the inductor

and output capacitor, then an abrupt 180° shift will occur. The current fed system will have 90° phase shift at a much lower frequency, but will not have the additional 90° shift until well beyond the LC resonant frequency. This makes it much easier to frequency compensate the feedback loop and also gives much quicker transient response.

High switch efficiency is attained by using the BOOST pin to provide a voltage to the switch driver which is higher than the input voltage, allowing switch to be saturated. This boosted voltage is generated with an external capacitor and diode. A comparator connected to the shutdown pin disables the internal regulator, reducing supply current.

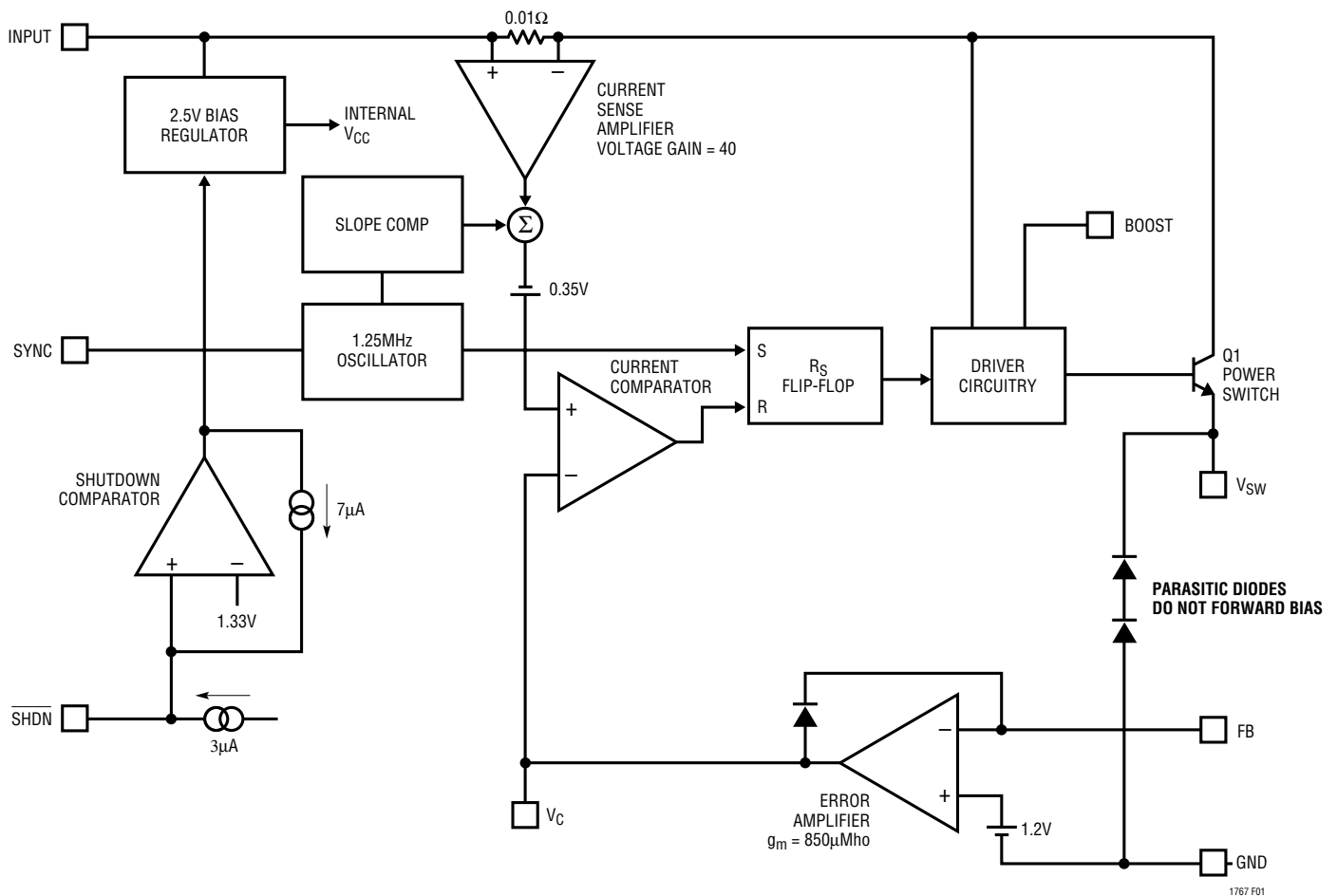

Figure 1. Block Diagram

APPLICATIONS INFORMATION

FB RESISTOR NETWORK

The suggested resistor (R2) from FB to ground is 10k. This reduces the contribution of FB input bias current to output voltage to less than 0.25%. The formula for the resistor (R1) from V_{OUT} to FB is:

$$R1 = \frac{R2(V_{OUT} - 1.2)}{1.2 - R2(0.25\mu A)}$$

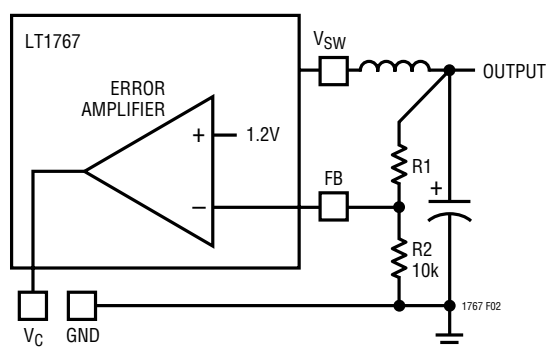

Figure 2. Feedback Network

INPUT CAPACITOR

Step-down regulators draw current from the input supply in pulses. The rise and fall times of these pulses are very fast. The input capacitor is required to reduce the voltage ripple this causes at the input of LT1767 and force the switching current into a tight local loop, thereby minimizing EMI. The RMS ripple current can be calculated from:

$$I_{RIPPLE(RMS)} = I_{OUT} \sqrt{V_{OUT}(V_{IN} - V_{OUT}) / V_{IN}^2}$$

Higher value, lower cost ceramic capacitors are now available in smaller case sizes. These are ideal for input bypassing since their high frequency capacitive nature removes most ripple current rating and turn-on surge problems. At higher switching frequency, the energy storage requirement of the input capacitor is reduced so values in the range of 1 μ F to 4.7 μ F are suitable for most applications. Y5V or similar type ceramics can be used since the absolute value of capacitance is less important and has no significant effect on loop stability. If operation

is required close to the minimum input required by the output or the LT1767, a larger value may be required. This is to prevent excessive ripple causing dips below the minimum operating voltage resulting in erratic operation.

If tantalum capacitors are used, values in the 22 μ F to 470 μ F range are generally needed to minimize ESR and meet ripple current and surge ratings. Care should be taken to ensure the ripple and surge ratings are not exceeded. The AVX TPS and Kemet T495 series are surge rated. AVX recommends derating capacitor operating voltage by 2:1 for high surge applications.

OUTPUT CAPACITOR

Unlike the input capacitor, RMS ripple current in the output capacitor is normally low enough that ripple current rating is not an issue. The current waveform is triangular, with an RMS value given by:

$$I_{RIPPLE(RMS)} = \frac{0.29(V_{OUT})(V_{IN} - V_{OUT})}{(L)(f)(V_{IN})}$$

The LT1767 will operate with both ceramic and tantalum output capacitors. Ceramic capacitors are generally chosen for their small size, very low ESR (effective series resistance), and good high frequency operation, reducing output ripple voltage. Their low ESR removes a useful zero in the loop frequency response, common to tantalum capacitors. To compensate for this, the V_C loop compensation pole frequency must typically be reduced by a factor of 10. Typical ceramic output capacitors are in the 1 μ F to 10 μ F range. Since the absolute value of capacitance defines the pole frequency of the output stage, an X7R or X5R type ceramic, which have good temperature stability, is recommended.

Tantalum capacitors are usually chosen for their bulk capacitance properties, useful in high transient load applications. ESR rather than absolute value defines output ripple at 1.25MHz. Typical LT1767 applications require a tantalum capacitor with less than 0.3 Ω ESR at 22 μ F to 500 μ F, see Table 2.

APPLICATIONS INFORMATION

Table 2. Surface Mount Solid Tantalum Capacitor ESR and Ripple Current

E Case Size	ESR (Max, Ω)	Ripple Current (A)
AVX TPS, Sprague 593D	0.1 to 0.3	0.7 to 1.1
AVX TAJ	0.7 to 0.9	0.4
D Case Size		
AVX TPS, Sprague 593D	0.1 to 0.3	0.7 to 1.1
C Case Size		
AVX TPS	0.2 (typ)	0.5 (typ)

Figure 3 shows a comparison of output ripple for a ceramic and tantalum capacitor at 200mA ripple current.

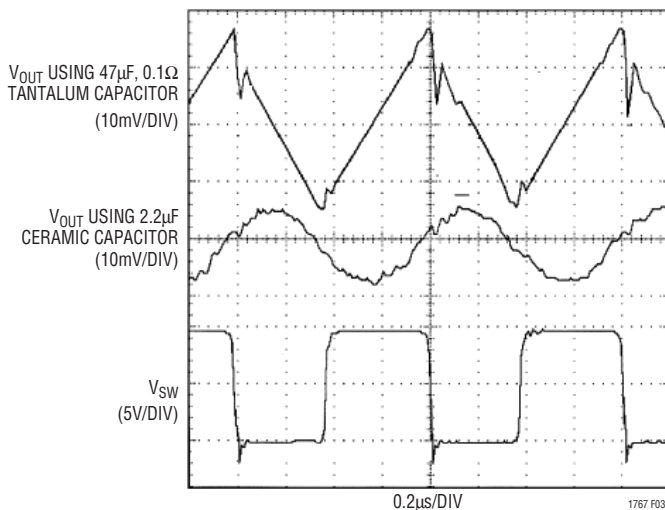

Figure 3. Output Ripple Voltage Waveform

INDUCTOR CHOICE AND MAXIMUM OUTPUT CURRENT

Maximum output current for a buck converter is equal to the maximum switch rating (I_P) minus one half peak to peak inductor current. In past designs, the maximum switch current has been reduced by the introduction of slope compensation. Slope compensation is required at duty cycles above 50% to prevent an affect called subharmonic oscillation (see Application Note 19 for details). The LT1767 has a new circuit technique that maintains a constant switch current rating at all duty cycles. (Patent Pending)

For most applications, the output inductor will be in the $1\mu\text{H}$ to $10\mu\text{H}$ range. Lower values are chosen to reduce the physical size of the inductor, higher values allow higher

output currents due to reduced peak to peak ripple current. The following formula gives maximum output current for continuous mode operation, implying that the peak to peak ripple (2x the term on the right) is less than the maximum switch current.

$$I_{\text{OUT(MAX)}} = I_P - \frac{(V_{\text{OUT}})(V_{\text{IN}} - V_{\text{OUT}})}{2(L)(f)(V_{\text{IN}})}$$

Continuous Mode

For $V_{\text{IN}} = 8\text{V}$, $V_{\text{OUT}} = 5\text{V}$ and $L = 3.3\mu\text{H}$,

$$I_{\text{OUT(MAX)}} = 1.5 - \frac{(5)(8 - 5)}{2(3.3 \cdot 10^{-6})(1.25 \cdot 10^6)(8)}$$

$$= 1.5 - 0.23 = 1.27\text{ A}$$

Note that the worst case (minimum output current available) condition is at the maximum input voltage. For the same circuit at 15V, maximum output current would be only 1.1A.

When choosing an inductor, consider maximum load current, core and copper losses, allowable component height, output voltage ripple, EMI, fault current in the inductor, saturation, and of course, cost. The following procedure is suggested as a way of handling these somewhat complicated and conflicting requirements.

1. Choose a value in microhenries from the graphs of maximum load current. Choosing a small inductor with lighter loads may result in discontinuous mode of operation, but the LT1767 is designed to work well in either mode.

Assume that the average inductor current is equal to load current and decide whether or not the inductor must withstand continuous fault conditions. If maximum load current is 0.5A, for instance, a 0.5A inductor may not survive a continuous 2A overload condition. Also, the instantaneous application of input or release from shutdown, at high input voltages, may cause saturation of the inductor. In these applications, the soft-start circuit shown in Figure 10 should be used.

2. Calculate peak inductor current at full load current to ensure that the inductor will not saturate. Peak current can be significantly higher than output current, especially with smaller inductors and lighter loads, so don't

APPLICATIONS INFORMATION

omit this step. Powdered iron cores are forgiving because they saturate softly, whereas ferrite cores saturate abruptly. Other core materials fall somewhere in between.

$$I_{PEAK} = I_{OUT} + \frac{V_{OUT}(V_{IN} - V_{OUT})}{2(L)(f)(V_{IN})}$$

V_{IN} = Maximum input voltage
 f = Switching frequency, 1.25MHz

- Decide if the design can tolerate an “open” core geometry like a rod or barrel, which have high magnetic field radiation, or whether it needs a closed core like a toroid to prevent EMI problems. This is a tough decision because the rods or barrels are temptingly cheap and small and there are no helpful guidelines to calculate when the magnetic field radiation will be a problem.
- After making an initial choice, consider the secondary things like output voltage ripple, second sourcing, etc. Use the experts in the Linear Technology’s applications department if you feel uncertain about the final choice. They have experience with a wide range of inductor types and can tell you about the latest developments in low profile, surface mounting, etc.

Table 3

PART NUMBER	VALUE (uH)	I _{RMS} (Amps)	DCR (Ω)	HEIGHT (mm)
Coiltronics				
TP1-2R2	2.2	1.3	0.188	1.8
TP2-2R2	2.2	1.5	0.111	2.2
TP3-4R7	4.7	1.5	0.181	2.2
TP4- 100	10	1.5	0.146	3.0
Murata				
LQH1C1R0M04	1.0	0.51	0.28	1.8
LQH3C1R0M24	1.0	1.0	0.06	2.0
LQH3C2R2M24	2.2	0.79	0.1	2.0
LQH4C1R5M04	1.5	1	0.09	2.6
Sumida				
CD73- 100	10	1.44	0.080	3.5
CDRH4D18-2R2	2.2	1.32	0.058	1.8
CDRH5D18-6R2	6.2	1.4	0.071	1.8
CDRH5D28-100	10	1.3	0.048	2.8

CATCH DIODE

The suggested catch diode (D1) is a 1N5818 Schottky, or its Motorola equivalent, MBR130. It is rated at 1A average forward current and 30V reverse voltage. Typical forward voltage is 0.5V at 1A. The diode conducts current only during switch off time. Peak reverse voltage is equal to regulator input voltage. Average forward current in normal operation can be calculated from:

$$I_{D(AVG)} = \frac{I_{OUT}(V_{IN} - V_{OUT})}{V_{IN}}$$

This formula will not yield values higher than 1A with maximum load current of 1.3A unless the ratio of input to output voltage exceeds 4.3:1. The only reason to consider a larger diode is the worst-case condition of a high input voltage and shorted output. With a shorted condition, diode current will increase to a typical value of 2A, determined by peak switch current limit. This is safe for short periods of time, but it would be prudent to check with the diode manufacturer if continuous operation under these conditions must be tolerated.

BOOST PIN

For most applications, the boost components are a 0.1μF capacitor and a 1N914 or 1N4148 diode. The anode is typically connected to the regulated output voltage to generate a voltage approximately V_{OUT} above V_{IN} to drive the output stage. The output driver requires at least 2.7V of headroom throughout the on period to keep the switch fully saturated. However, the output stage discharges the boost capacitor during the on time. If the output voltage is less than 3.3V, it is recommended that an alternate boost supply is used. The boost diode can be connected to the input, although, care must be taken to prevent the $2x V_{IN}$ boost voltage from exceeding the BOOST pin absolute maximum rating. The additional voltage across the switch driver also increases power loss, reducing efficiency. If available, an independent supply can be used with a local bypass capacitor.

A 0.1μF boost capacitor is recommended for most applications. Almost any type of film or ceramic capacitor is suitable, but the ESR should be $<1\Omega$ to ensure it can be

APPLICATIONS INFORMATION

fully recharged during the off time of the switch. The capacitor value is derived from worst-case conditions of 700ns on-time, 50mA boost current, and 0.7V discharge ripple. This value is then guard banded by 2x for secondary factors such as capacitor tolerance, ESR and temperature effects. The boost capacitor value could be reduced under less demanding conditions, but this will not improve circuit operation or efficiency. Under low input voltage and low load conditions, a higher value capacitor will reduce discharge ripple and improve start up operation.

SHUTDOWN AND UNDERVOLTAGE LOCKOUT

Figure 4 shows how to add undervoltage lockout (UVLO) to the LT1767. Typically, UVLO is used in situations where the input supply is *current limited*, or has a relatively high source resistance. A switching regulator draws constant power from the source, so source current increases as source voltage drops. This looks like a negative resistance load to the source and can cause the source to current limit or latch low under low source voltage conditions. UVLO prevents the regulator from operating at source voltages where these problems might occur.

An internal comparator will force the part into shutdown below the minimum V_{IN} of 2.6V. This feature can be used to prevent excessive discharge of battery-operated systems. If an adjustable UVLO threshold is required, the shutdown pin can be used. The threshold voltage of the shutdown pin comparator is 1.33V. A 3 μ A internal current source defaults the open pin condition to be operating (see Typical Performance Graphs). Current hysteresis is added

above the SHDN threshold. This can be used to set voltage hysteresis of the UVLO using the following:

$$R1 = \frac{V_H - V_L}{7\mu A}$$

$$R2 = \frac{1.33V}{\frac{(V_H - 1.33V)}{R1} + 3\mu A}$$

V_H – Turn-on threshold

V_L – Turn-off threshold

Example: switching should not start until the input is above 4.75V and is to stop if the input falls below 4.25V.

$V_H = 4.75V$

$V_L = 4.25V$

$$R1 = \frac{4.75V - 4.25V}{7\mu A} = 71.4k$$

$$R2 = \frac{1.33V}{\frac{(4.75V - 1.33V)}{71.4k} + 3\mu A} = 26.1k$$

Keep the connections from the resistors to the SHDN pin short and make sure that the interplane or surface capacitance to the switching nodes are minimized. If high resistor values are used, the SHDN pin should be bypassed with a 1nF capacitor to prevent coupling problems from the switch node.

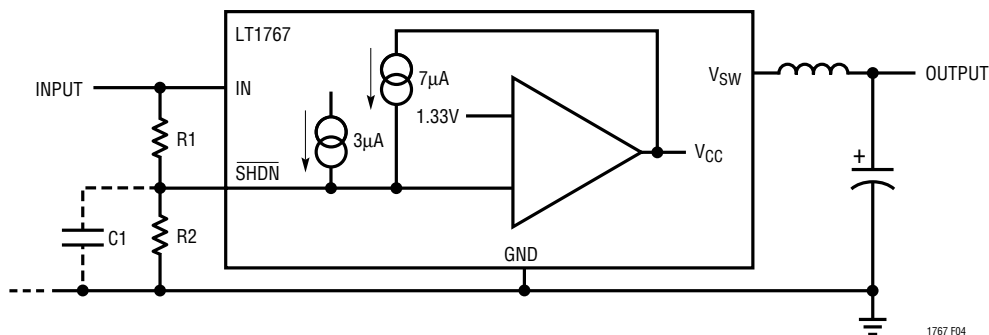

Figure 4. Undervoltage Lockout

APPLICATIONS INFORMATION

SYNCHRONIZATION

The SYNC pin, is used to synchronize the internal oscillator to an external signal. The SYNC input must pass from a logic level low, through the maximum synchronization threshold with a duty cycle between 20% and 80%. The input can be driven directly from a logic level output. The synchronizing range is equal to *initial* operating frequency up to 2MHz. This means that *minimum* practical sync frequency is equal to the worst-case *high* self-oscillating frequency (1.4MHz), not the typical operating frequency of 1.25MHz. Caution should be used when synchronizing above 1.6MHz because at higher sync frequencies the amplitude of the internal slope compensation used to prevent subharmonic switching is reduced. This type of subharmonic switching only occurs at input voltages less than twice output voltage. Higher inductor values will tend to eliminate this problem. See Frequency Compensation section for a discussion of an entirely different cause of subharmonic switching before assuming that the cause is insufficient slope compensation. Application Note 19 has more details on the theory of slope compensation.

LAYOUT CONSIDERATIONS

As with all high frequency switchers, when considering layout, care must be taken in order to achieve optimal electrical, thermal and noise performance. For maximum efficiency, switch rise and fall times are typically in the nanosecond range. To prevent noise both radiated and conducted, the high speed switching current path, shown

in Figure 5, must be kept as short as possible. This is implemented in the suggested layout of Figure 6. Shortening this path will also reduce the parasitic trace inductance of approximately 25nH/inch. At switch off, this parasitic inductance produces a flyback spike across the LT1767 switch. When operating at higher currents and input voltages, with poor layout, this spike can generate voltages across the LT1767 that may exceed its absolute maximum rating. A ground plane should always be used under the switcher circuitry to prevent interplane coupling and overall noise.

The V_C and FB components should be kept as far away as possible from the switch and boost nodes. The LT1767 pinout has been designed to aid in this. The ground for these components should be separated from the switch current path. Failure to do so will result in poor stability or subharmonic like oscillation.

Board layout also has a significant effect on thermal resistance. Pin 4, GND, is a continuous copper plate that runs under the LT1767 die. This is the best thermal path for heat out of the package. Reducing the thermal resistance from Pin 4 onto the board will reduce die temperature and increase the power capability of the LT1767. This is achieved by providing as much copper area as possible around this pin. Adding multiple solder filled feedthroughs under and around Pin 4 to the ground plane will also help. Similar treatment to the catch diode and coil terminations will prevent any additional heating effects.

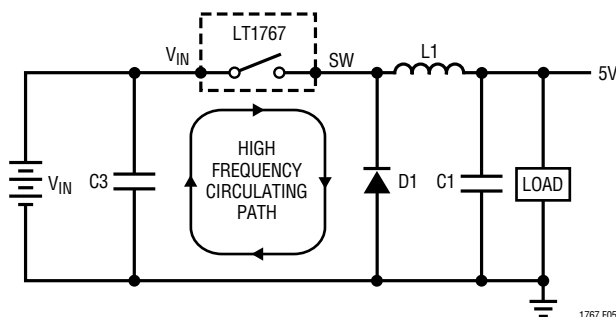

Figure 5. High Speed Switching Path

APPLICATIONS INFORMATION

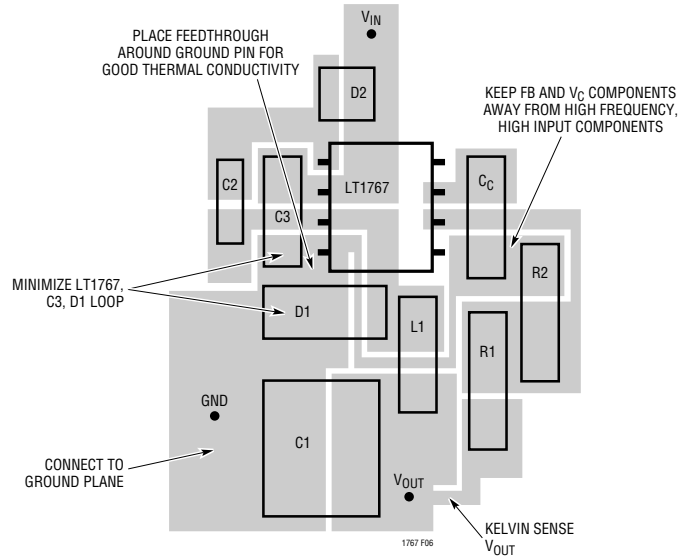
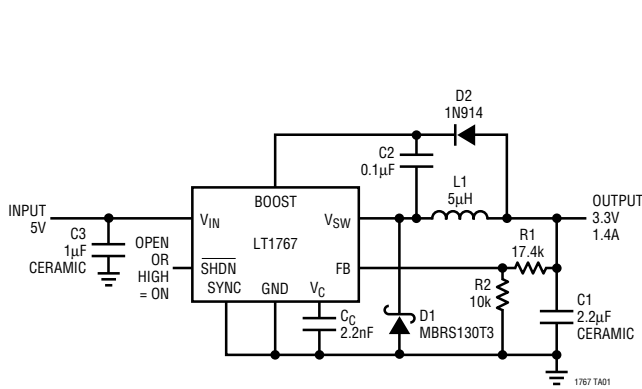

Figure 6. Typical Application and Suggested Layout (Topside Only Shown)

THERMAL CALCULATIONS

Power dissipation in the LT1767 chip comes from four sources: switch DC loss, switch AC loss, boost circuit current, and input quiescent current. The following formulas show how to calculate each of these losses. These formulas assume continuous mode operation, so they should not be used for calculating efficiency at light load currents.

Switch loss:

$$P_{SW} = \frac{R_{SW}(I_{OUT})^2(V_{OUT})}{V_{IN}} + 17ns(I_{OUT})(V_{IN})(f)$$

Boost current loss for $V_{BOOST} = V_{OUT}$:

$$P_{BOOST} = \frac{V_{OUT}^2(I_{OUT}/50)}{V_{IN}}$$

Quiescent current loss:

$$P_Q = V_{IN}(0.001)$$

R_{SW} = Switch resistance ($\approx 0.27\Omega$ – hot)
 17ns = Equivalent switch current/voltage overlap time
 f = Switch frequency
 Example: with $V_{IN} = 10V$, $V_{OUT} = 5V$ and $I_{OUT} = 1A$:

$$P_{SW} = \frac{(0.27)(1)^2(5)}{10} + (17 \cdot 10^{-9})(1)(10)(1.25 \cdot 10^6)$$

$$= 0.135 + 0.21 = 0.34W$$

$$P_{BOOST} = \frac{(5)^2(1/50)}{10} = 0.05W$$

$$P_Q = 10(0.001) = 0.01W$$

Total power dissipation is $0.34 + 0.05 + 0.01 = 0.4W$.

Thermal resistance for LT1767 package is influenced by the presence of internal or backside planes. With a full plane under the package, thermal resistance will be about $110^\circ C/W$. No plane will increase resistance to about $150^\circ C/W$. To calculate die temperature, use the appropriate thermal resistance number and add in worst-case ambient temperature:

$$T_J = T_A + \theta_{JA}(P_{TOT})$$

When estimating ambient, remember the nearby catch diode and inductor will also be dissipating power.

$$P_{DIODE} = \frac{(V_F)(V_{IN} - V_{OUT})(I_{LOAD})}{V_{IN}}$$

V_F = Forward voltage of diode (assume 0.5V at 1A)

APPLICATIONS INFORMATION

$$P_{\text{DIODE}} = \frac{(0.5)(12 - 5)(1)}{12} = 0.29\text{W}$$

Notice that the catch diode's forward voltage contributes a significant loss in the overall system efficiency. A larger, lower V_F diode can improve efficiency by several percent.

$$P_{\text{INDUCTOR}} = (I_{\text{LOAD}}) (L_{\text{DCR}})$$

$$L_{\text{DCR}} = \text{Inductor DC resistance (assume } 0.1\Omega)$$

$$P_{\text{INDUCTOR}} = (1) (0.1) = 0.1\text{W}$$

Typical thermal resistance of the board is 35°C/W . At an ambient temperature of 65°C ,

$$T_j = 65 + 110 (0.4) + 35 (0.39) = 123^\circ\text{C}$$

Die temperature is highest at low input voltage, so use lowest continuous input operating voltage for thermal calculations. If a true die temperature is required, a measurement of the SYNC to GND pin resistance can be used. The SYNC pin resistance across temperature must first be calibrated, with no device power, in an oven. The same measurement can then be used in operation to indicate the die temperature.

FREQUENCY COMPENSATION

Before starting on the theoretical analysis of frequency response, the following should be remembered – the worse the board layout, the more difficult the circuit will be to stabilize. This is true of almost all high frequency analog circuits, read the 'LAYOUT CONSIDERATIONS' section first. Common layout errors that appear as stability problems are distant placement of input decoupling capacitor and/or catch diode, and connecting the V_C compensation to a ground track carrying significant switch current. In addition, the theoretical analysis considers only first order non-ideal component behavior. For these reasons, it is important that a final stability check is made with production layout and components.

The LT1767 uses current mode control. This alleviates many of the phase shift problems associated with the inductor. The basic regulator loop is shown in Figure 7, with both tantalum and ceramic capacitor equivalent circuits. The LT1767 can be considered as two g_m blocks, the error amplifier and the power stage.

Figure 8 shows the overall loop response with a 330pF V_C capacitor and a typical $100\mu\text{F}$ tantalum output capacitor. The response is set by the following terms:

Error amplifier:

DC gain set by g_m and $R_L = 850\mu \cdot 500\text{k} = 425$. Pole set by C_F and $R_L = (2\pi \cdot 500\text{k} \cdot 330\text{p})^{-1} = 965\text{Hz}$. Unity-gain set by C_F and $g_m = (2\pi \cdot 330\text{p} \cdot 850\mu^{-1})^{-1} = 410\text{kHz}$.

Power stage:

DC gain set by g_m and R_L (assume 10Ω) = $2.5 \cdot 10 = 25$. Pole set by C_{OUT} and $R_L = (2\pi \cdot 100\mu \cdot 10)^{-1} = 159\text{Hz}$. Unity-gain set by C_{OUT} and $g_m = (2\pi \cdot 100\mu \cdot 2.5^{-1})^{-1} = 3.98\text{kHz}$.

Tantalum output capacitor:

Zero set by C_{OUT} and $C_{\text{ESR}} = (2\pi \cdot 100\mu \cdot 0.1)^{-1} = 15.9\text{kHz}$.

The zero produced by the ESR of the tantalum output capacitor is very useful in maintaining stability. Ceramic output capacitors do not have a zero due to very low ESR, but are dominated by their ESL. They form a notch in the 1MHz to 10MHz range. Without this zero, the V_C pole must be made dominant. A typical value of 2.2nF will achieve this.

If better transient response is required, a zero can be added to the loop using a resistor (R_C) in series with the compensation capacitor. As the value of R_C is increased, transient response will generally improve, but two effects limit its value. First, the combination of output capacitor ESR and a large R_C may stop loop gain rolling off altogether. Second, if the loop gain is not rolled sufficiently at the switching frequency, output ripple will perturb the V_C pin enough to cause unstable duty cycle switching similar to subharmonic oscillation. This may not be apparent at the output. Small signal analysis will not show this since a continuous time system is assumed. If needed, an additional capacitor (C_F) can be added to form a pole at typically one fifth the switching frequency (If $R_C = \sim 5\text{k}$, $C_F = \sim 100\text{pF}$)

When checking loop stability, the circuit should be operated over the application's full voltage, current and temperature range. Any transient loads should be applied and the output voltage monitored for a well-damped behavior.

APPLICATIONS INFORMATION

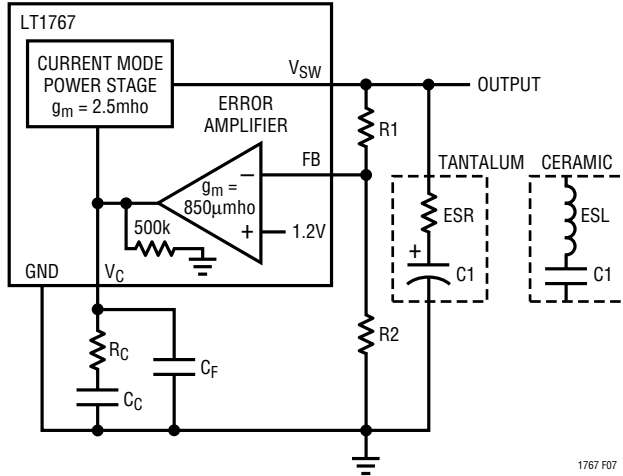

Figure 7. Model for Loop Response

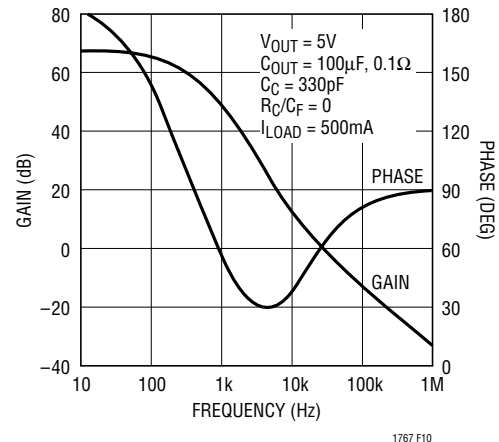

Figure 8. Overall Loop Response

CONVERTER WITH BACKUP OUTPUT REGULATOR

In systems with a primary and backup supply, for example, a battery powered device with a wall adapter input, the output of the LT1767 can be held up by the backup supply with its input disconnected. In this condition, the SW pin will source current into the VIN pin. If the SHDN pin is held at ground, only the shut down current of 6µA will be pulled via the SW pin from the second supply. With the SHDN pin floating, the LT1767 will consume its quiescent operating current of 1mA. The VIN pin will also source current to any other components connected to the input line. If this load is greater than 10mA or the input could be shorted to ground, a series Schottky diode must be added, as shown in Figure 9. With these safeguards, the output can be held at voltages up to the VIN absolute maximum rating.

BUCK CONVERTER WITH ADJUSTABLE SOFT-START

Large capacitive loads or high input voltages can cause high input currents at start-up. Figure 10 shows a circuit that limits the dv/dt of the output at start-up, controlling the capacitor charge rate. The buck converter is a typical configuration with the addition of R3, R4, CSS and Q1. As the output starts to rise, Q1 turns on, regulating switch current via the VC pin to maintain a constant dv/dt at the output. Output rise time is controlled by the current through CSS defined by R4 and Q1's VBE. Once the output

is in regulation, Q1 turns off and the circuit operates normally. R3 is transient protection for the base of Q1.

$$\text{RiseTime} = \frac{(R4)(CSS)(V_{OUT})}{(V_{BE})}$$

Using the values shown in Figure 10,

$$\text{RiseTime} = \frac{(47 \cdot 10^3)(15 \cdot 10^{-9})(5)}{0.7} = 5\text{ms}$$

The ramp is linear and rise times in the order of 100ms are possible. Since the circuit is voltage controlled, the ramp rate is unaffected by load characteristics and maximum output current is unchanged. Variants of this circuit can be used for sequencing multiple regulator outputs.

Dual Output SEPIC Converter

The circuit in Figure 11 generates both positive and negative 5V outputs with a single piece of magnetics. The two inductors shown are actually just two windings on a standard B H Electronics inductor. The topology for the 5V output is a standard buck converter. The -5V topology would be a simple flyback winding coupled to the buck converter if C4 were not present. C4 creates a SEPIC (single-ended primary inductance converter) topology which improves regulation and reduces ripple current in L1. Without C4, the voltage swing on L1B compared to L1A would vary due to relative loading and coupling

APPLICATIONS INFORMATION

losses. C4 provides a low impedance path to maintain an equal voltage swing in L1B, improving regulation. In a flyback converter, during switch on time, all the converter's energy is stored in L1A only, since no current flows in L1B. At switch off, energy is transferred by magnetic coupling into L1B, powering the -5V rail. C4 pulls L1B positive

during switch on time, causing current to flow, and energy to build in L1B and C4. At switch off, the energy stored in both L1B and C4 supply the -5V rail. This reduces the current in L1A and changes L1B current waveform from square to triangular. For details on this circuit, including maximum output currents, see Design Note 100.

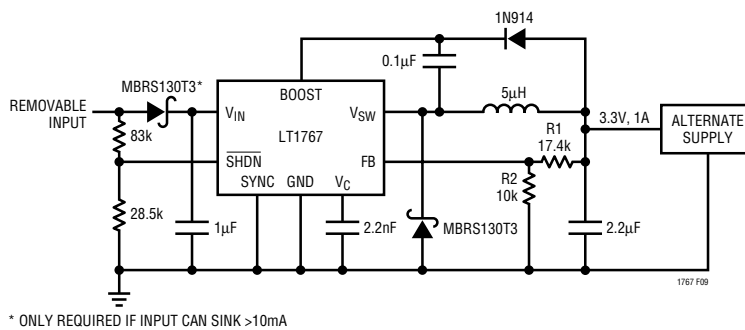

Figure 9. Dual Source Supply with 6µA Reverse Leakage

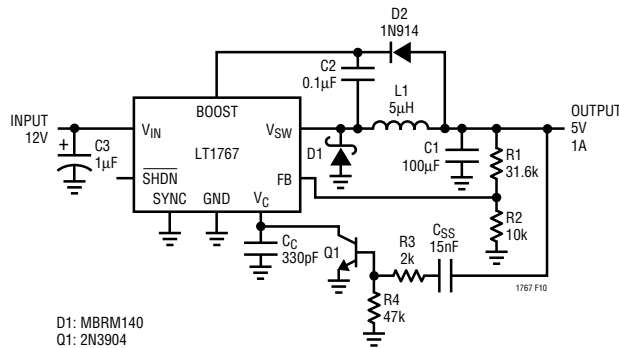

Figure 10. Buck Converter with Adjustable Soft Start

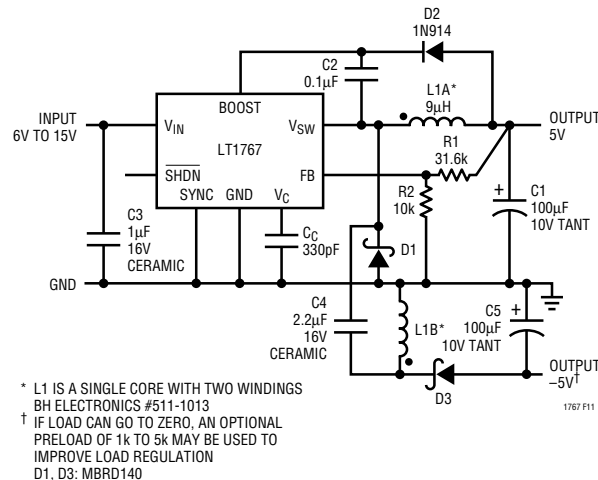
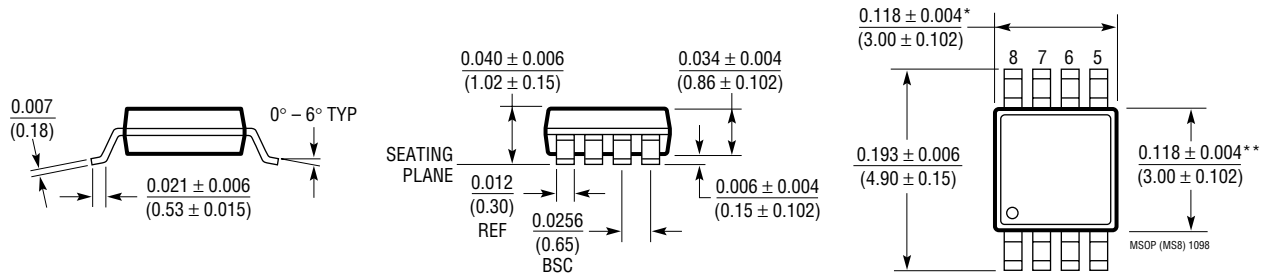

Figure 11. Dual Output SEPIC Converter

PACKAGE DESCRIPTION Dimensions in inches (millimeters) unless otherwise noted.

MS8 Package
8-Lead Plastic MSOP
 (LTC DWG # 05-08-1660)



* DIMENSION DOES NOT INCLUDE MOLD FLASH, PROTRUSIONS OR GATE BURRS. MOLD FLASH, PROTRUSIONS OR GATE BURRS SHALL NOT EXCEED 0.006* (0.152mm) PER SIDE
 ** DIMENSION DOES NOT INCLUDE INTERLEAD FLASH OR PROTRUSIONS. INTERLEAD FLASH OR PROTRUSIONS SHALL NOT EXCEED 0.006* (0.152mm) PER SIDE

RELATED PARTS

PART NUMBER	DESCRIPTION	COMMENTS
LT1370	High Efficiency DC/DC Converter	42V, 6A, 500kHz Switch
LT1371	High Efficiency DC/DC Converter	35V, 3A, 500kHz Switch
LT1372/LT1377	500kHz and 1MHz High Efficiency 1.5A Switching Regulators	Boost Topology
LT1374	High Efficiency Step-Down Switching Regulator	25V, 4.5A, 500kHz Switch
LT1375/LT1376	1.5A Step-Down Switching Regulators	500kHz, Synchronizable in SO-8 Package
LT1507	1.5A Step-Down Switching Regulator	500kHz, 4V to 16V Input, SO-8 Package
LT1576	1.5A Step-Down Switching Regulator	200kHz, Reduced EMI Generation
LT1578	1.5A Step-Down Switching Regulator	200kHz, Reduced EMI Generation
LT1616	600mA Step-Down Switching Regulator	1.4MHz, 4V to 25V Input, SOT-23 Package
LT1676/LT1776	Wide Input Range Step-Down Switching Regulators	60V Input, 700mA Internal Switches
LTC1735	High Efficiency Synchronous Step-Down, N-Ch Drive	Burst Mode™ Operation, 16-Pin Narrow SSOP
LTC1735-1	High Efficiency Step-Down Controller with Power Good	Output Fault Protection, 16-Pin SSOP and SO-8
LTC1877	High Efficiency Monolithic Step-Down Regulator	550kHz, MS8, V _{IN} Up to 10V, I _Q = 10µA, I _{OUT} to 600mA at V _{IN} = 5V
LTC1878	High Efficiency Monolithic Step-Down Regulator	550kHz, MS8, V _{IN} Up to 6V, I _Q = 10µA, I _{OUT} to 600mA at V _{IN} = 3.3V
LTC3401	Single Cell, High Current (1A), Micropower, Synchronous 3MHz Step-Up DC/DC Converter	V _{IN} = 0.5V to 5V, Up to 97% Efficiency Synchronizable Oscillator from 100kHz to 3MHz
LTC3402	Single Cell, High Current (2A), Micropower, Synchronous 3MHz Step-Up DC/DC Converter	V _{IN} = 0.7V to 5V, Up to 95% Efficiency Synchronizable Oscillator from 100kHz to 3MHz
LTC3404	1.4MHz High Efficiency, Monolithic Synchronous Step-Down Regulator	Up to 95% Efficiency, 100% Duty Cycle, I _Q = 10µA, V _{IN} = 2.65V to 6V

Burst Mode is a trademark of Linear Technology Corporation.